

# Time-Triggered Smart Transducer Networks

Wilfried Elmenreich  
wilfried.elmenreich@aau.at

IEEE Trans. on Industrial Informatics, 2(3):192199, 2006

## Abstract

The time-triggered approach is a well-suited approach for building distributed hard real-time systems. Since many applications of transducer networks have real-time requirements, a time-triggered communication interface for smart transducers is desirable, however such a time-triggered interface must still support features for monitoring, maintenance, plug-and-play, etc.

The approach of the Object Management Group (OMG) Smart Transducer Interface consists of clusters of time-triggered smart transducer nodes that contain special interfaces supporting configuration, diagnostics, and maintenance without affecting the deterministic real-time communication. This paper discusses the applicability of the time-triggered approach for smart transducer networks and presents a case study application of a time-triggered smart transducer network.

## 1 Introduction

With the advent of modern microcontrollers it became feasible to build low-cost smart transducers by equipping sensors and actuators with a microcontroller and a standard network interface. Several smart transducers are connected to a cluster using a standard or non-standard fieldbus network. Many applications that interact with the environment via transducers have real-time requirements, that is to make correct actions at the right time. So there is a need for an appropriate real-time communication interface for smart transducers.

There are two major design paradigms for implementing distributed real-time systems, the event-triggered and the time-triggered approach. Simplified, an event triggered system follows the principle of reaction on demand. In such systems, the environment enforces temporal control onto the system in an unpredictable manner (interrupts), with all the undesirable problems of jitter, missing precise temporal specification of interfaces and membership, scheduling etc. On the other hand, the event-triggered approach is well-suited for sporadic action/data, low-power sleep modes, and best-effort soft real-time systems with high utilization of resources. Event-triggered systems do not ideally cope with the demands for predictability, determinism, and guaranteed latencies – requirements that must be met in a hard real-time system. Time-triggered systems derive

all triggers for communication, computation, sensing and control by the global progression of time. In this approach the concept of time is prevalent in the problem statement as well as in the provided solution.

The objective of this paper is to present a time-triggered approach for smart transducer networks that supports the hard real-time requirements of embedded applications while still providing features for maintenance and plug-and-play.

The remaining parts of this paper are structured as follows: The next section identifies basic requirements for smart transducer networks. Section 3 depicts the generic model of a time-triggered system. Section 4 describes the OMG Smart Transducer Standard, which incorporates a time-triggered communication interface to smart transducers while fulfilling the requirements for a smart transducer. Section 6 gives an overview on related work on time-triggered smart transducer networks. Section 7 concludes the paper.

## 2 Requirements for Smart Transducers

We make the following assumption: The sensors and actuators in the system are distributed and implemented as smart transducers with a network interface. The network connects these smart transducers to a communication system with broadcast characteristics (e. g., bus or star topology). The network also contains local intelligence, e. g., for feedback control purposes or sensor information processing. This intelligence is either implemented in the processing unit of the smart transducers or provided by separate control nodes.

Large transducer networks will be divided into clusters where each cluster connects a set of transducers via a bus. A gateway node exports the interfaces of the nodes in the cluster to a backbone network.

We have identified the following requirements for smart transducers in such a network:

**Real-Time Operation:** Most applications for transducers, especially in the fields of process automation, automotive and avionic networks, require timely actions, e. g., for information gathering, sensor processing and actuator setting. Thus, a smart transducer should provide a real-time interface that allows for such a coordination.

**Complexity management:** The number of sensors and actuators employed in a typical system has drastically increased in the last two decades. Thus, a smart transducer should provide means to manage the system complexity when composing or changing a network of transducers, e. g., by supporting electronic datasheets. Electronic datasheets contain a machine-readable self-description of the transducer which can be used to support a plug-and-play-like computer aided configuration (cf. [1]).

| Time   | [0:00,3:00) | [3:00,5:00) | [5:00,8:00)  | [8:00, 12:00) |
|--------|-------------|-------------|--------------|---------------|
| Node A | send        | receive     | receive      | execute task  |
| Node B | receive     | send        | receive      | send          |
| Node C | receive     | receive     | execute task | receive       |
| Node D | receive     | receive     | idle         | receive       |

Table 1: Example for a time-triggered schedule

**Maintenance support:** Systems which are in operation for an extended period of time usually require maintenance access to smart transducers, e. g., for reading sensor logs, calibration or trimming of the sensor’s output.

Often, the information to be monitored is not fully covered by the data exchanged via the real-time interface. Therefore, the monitoring operation requires an extra data channel for communication of these additional data. In this case, it is required that the real-time traffic among the transducers is not affected by the monitoring operation in order to avoid a “Probe Effect” [2, 3] on the system.

An appropriate interface is essential for supporting effective maintenance methods such as Condition-Based Maintenance [4] where affected components are repaired or replaced before their failure causes greater costs.

**Deterministic Behavior:** A system is deterministic, if a given set of inputs always leads to the same system output. Determinism is especially important if replicated transducers are used to enhance the dependability of an application. For real-time systems, a deterministic system must, for a given set of inputs, always produce the same output with regard to values and timing.

Since transducers operate on the borderline to the analog process environment, determinism is difficult to achieve. For example, in the case of a sensor, the input comes from the process environment, which is an analog system. Thus, even a digital sensor will not be exactly value deterministic due to digitalization and intrinsic sensor errors. If a system contains such sources of indeterminism, consistency must be achieved by mechanisms like inexact voting [5], sensor fusion [6], and sparse time [7].

### 3 The Time-Triggered Approach

The core mechanism of a time-triggered system is very simple. A global schedule defines for each node which action it has to take at a given point in time.

This schedule is executed periodically. A prerequisite for time-triggered systems is that all communication partners agree on the current execution state of the schedule and that the duration of all communication and computation activities are bounded and an upper bound for this duration is known.

An example for such a schedule is given in Table 1. Within a cycle, depicted by the *cycle time*, each message is scheduled at a predefined point in time – in this example, a

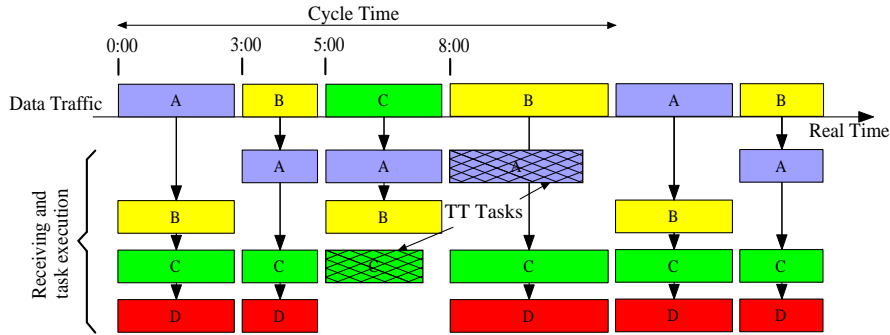

Figure 1: Execution of time-triggered schedule

message from node A is scheduled at time 0:00, a message from node B at 3:00, a message from node C is scheduled at 5:00 and another message from node B is scheduled at 8:00. Figure 1 depicts the execution of this schedule.

For a network of transducers, the time-triggered approach comes with the following advantages:

**Global time:** The global synchronized time is a requirement and a feature in time-triggered systems. The global time must be established by periodic clock synchronization in order to enable time-triggered communication and computation [8, p. 52].

In case of a smart transducer, the global time provides each measurement with a timestamp that can be globally interpreted.

**Conflict-free bus arbitration:** Time-triggered systems need no explicit arbitration mechanism for bus access, since all communication actions are scheduled at predefined points in time. This simplifies communication design by making it possible to omit message retry mechanisms and special data encodings for detecting data collisions on the bus. Moreover, the electrical specification of the bus system is not required to cover the case of multiple partners concurrently accessing the communication medium as senders.[8, p. 176]

**Synchronization of distributed actions:** The time-triggered schedule allows a precise coordination of actions in the network. Examples for such synchronization actions are:

- Synchronous measurements by several distributed sensors: If the measured variable is a fast moving real-time value, unsynchronized measurements from multiple sensors will lead to significantly different results.
- Cascaded measurements to avoid interference: Sensors that emit an active signal, for example ultrasonic distance sensors, may interfere with each other if the measurement is started concurrently.

- Synchronous actuating: Applications where two or more actuators are manipulating the same process might require synchronous action. An example for this case is an application with multiple servos applied to the same shaft, where an unsynchronized execution leads to increased electrical current flow and load for the servo that actuates first.

**Determinism:** Because of the time-triggered coordination, sources of indeterminism like race conditions are removed by design. Time-triggered systems are therefore deterministic in the value and in the time domain. This factor is especially important in the case of replicated systems where voting is used on the outputs to enhance dependability (cf. replica determinism [9]).

Note that time-triggered communication alone, i. e., using a Time Division Multiple Access (TDMA) communication scheme, is not sufficient to establish a time-triggered architecture. For example in the Local Interconnect Network (LIN) system [10], the master follows a time-triggered communication schedule, while the interface to the LIN nodes operates on a polling principle. Thus, LIN does not support synchronized measurements of multiple sensors within one cluster.

The most prominent example for a time-triggered approach is the Time-Triggered Architecture [7], which provides a highly dependable real-time communication service with a fault-tolerant clock synchronization scheme and error detection of faulty nodes. This architecture is suitable to build ultra-dependable computer systems for safety-critical applications, where a mean-time-to-failure (MTTF) of better than  $10^9$  hours is required [11, 12].

## 4 OMG Smart Transducer Standard

In December 2000 the OMG called for a proposal of a Smart Transducer Interface (STI) standard [13]. In response, a new standard has been proposed that comprises a time-triggered transport service within the distributed smart transducer network and a well-defined interface to a CORBA (Common Object Request Broker Architecture) environment. The key feature of the STI is the concept of an Interface File System (IFS) that contains all relevant transducer data. This IFS allows different views of a system, namely a real-time service view, a diagnostic and management view, and a configuration and planning view. The interface concept encompasses a communication model for transparent time-triggered communication. This STI standard has been finalized by the OMG in January 2003 [14].

The STI standard defines a smart transducer system as a system comprising of several clusters with transducer nodes connected to a bus. Via a master node, each cluster is connected to a CORBA gateway. The master nodes of each cluster share a synchronized time that supports coordinated actions (e. g., synchronized measurements) over transducer nodes in several clusters. Each cluster can address up to 250 smart transducers that communicate via a cluster-wide broadcast communication channel. There may

be redundant shadow masters to support fault tolerance. One active master controls the communication within a cluster (in the following sections the term master refers to the active master unless stated otherwise). Since smart transducers are controlled by the master, they are called slave nodes. Figure 2 depicts an example for such a smart transducer system.

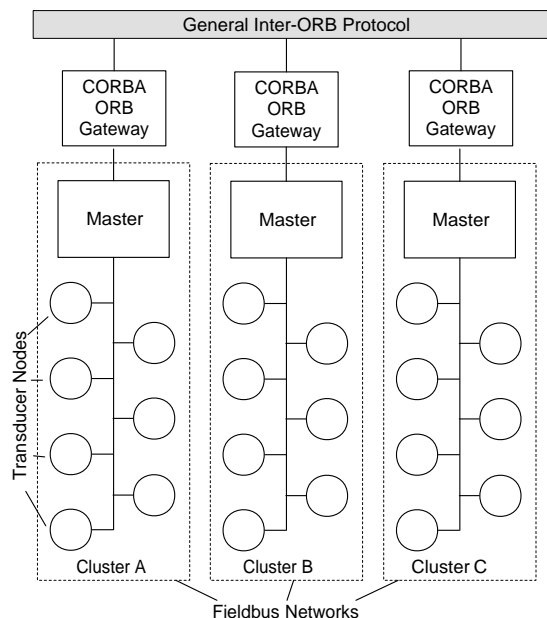

Figure 2: Multi-Cluster Architecture with CORBA Gateway

It is possible to monitor the smart transducer system via the CORBA interface without disturbing the real-time traffic.

The STI standard is very flexible concerning the hardware requirements for smart transducer nodes, since it only requires a minimum agreed set of services for a smart transducer implementation, thus supporting low-cost implementations of smart transducers, while allowing optional implementation of additional standard features.

The information transfer between a smart transducer and its client is achieved by sharing information that is contained in an internal IFS, which is encapsulated in each smart transducer.

**Interface File System.** The IFS [15] provides a unique addressing scheme to all relevant data in the smart transducer network, i. e., transducer data, configuration data, self-describing information, and internal state reports of a smart transducer. The values that are mapped into the IFS are organized in a static file structure that is organized hierarchically representing the network structure (Table 2).

| Element       | Size  | Description  |
|---------------|-------|--|
| Cluster name  | 8 bit | Identifies a particular cluster. Native communication (without routing) among nodes is only possible within the same cluster.  |
| Node alias    | 8 bit | The node alias or logical name selects a particular node. Some values have an associated special function, e.g., alias 0 addresses all nodes of a cluster in a broadcast manner  |
| File name     | 6 bit | The file name addresses a certain file within a node. A subset of files, the system files, have a special meaning in all nodes. Each service of a node is mapped onto a file containing sections for the service providing and service requesting linking interface as well as for configuration/planning and diagnosis/management data. |
| Record number | 8 bit | Each file has a statically assigned number of records. The record number addresses the record within the selected file. Each record contains 4 data bytes. Note that each file contains only the necessary number of records, thus, the number of addressable records is statically defined for each file.                               |

Table 2: Hierarchical structure of an IFS address

**Communication via temporal firewalls.** A time-triggered sensor bus will perform a periodical time-triggered communication to copy data from the IFS to the fieldbus and to write received data into the IFS. Thus, the IFS is the source and sink for all communication activities. Furthermore, the IFS acts as a temporal firewall that decouples the local transducer application from the communication activities. A temporal firewall [16] is a fully specified interface for the unidirectional exchange of state information between a sender/receiver over a time-triggered communication system. The basic data and control transfer of a temporal firewall interface is depicted in Figure 3, showing the data and control flow between a sender and a receiver. The IFS at the sender forms the output firewall of the sender and the IFS of the receiver forms the input firewall of the receiver. Thus, small timing errors at the sender do not propagate through the communication channel (significant timing errors are recognized as a failure).

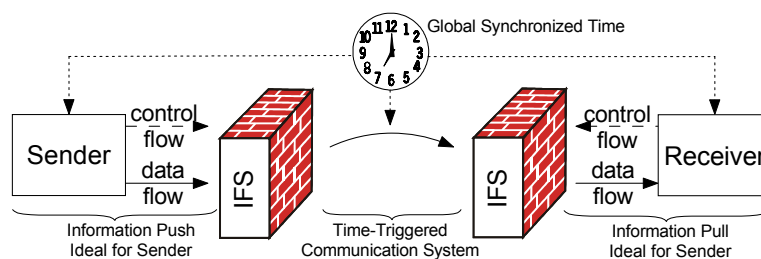

Figure 3: Temporal Firewall

**Flow control using information push and pull paradigms.** The sender deposits its output information into its local IFS according to the information *push* paradigm, while the receiver must *pull* the input information out of its local IFS (non-consumable read) [17]. In the information push model the sender presses information on the receiver. It is ideal for the sender, because the sender can determine the instant for passing outgoing information to the communication system. The information pull model is ideal for the receiver, since tasks of the receiver will not be interrupted by incoming messages. The transport of the information is realized by a time-triggered communication system that derives its control signals autonomously from the progression of time. The instants when typed data structures are fetched from the sender’s IFS and the instants when these typed data structures are delivered to the receiver’s IFS are common knowledge of the sender and the receiver. A predefined communication schedule defines time, origin and destination of each communication activity. Thus, the IFS acts as a *temporally specified interface* that decouples the local transducer application from the communication task.

#### 4.1 Interface Separation

If different user groups access the system for different purposes, they should only be provided with an interface to the information relevant for their respective purpose [18]. Therefore, interfaces for different purposes may differ by the accessible information and



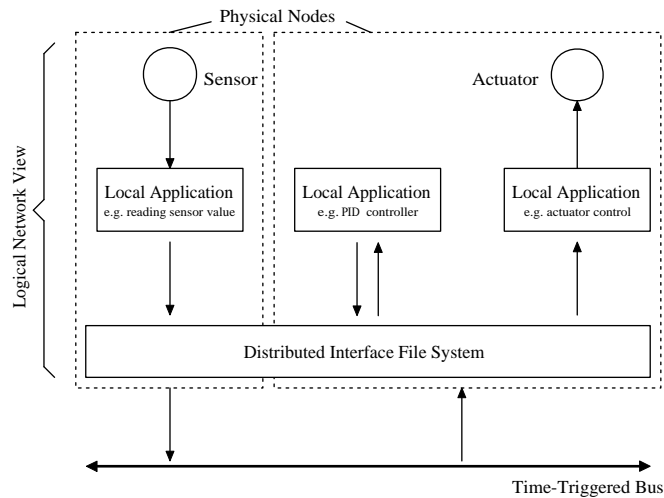

Figure 4: Logical network view of a distributed smart transducer application

in the temporal behavior of the access across the interface. As depicted in Figure 5, the STI specifies three different interface types to a smart transducer:

**DM interface:** This is a *diagnostic and management* interface. It establishes a connection to a particular smart transducer node and allows reading or modifying of specific IFS records. Most sensors need parametrization and calibration at startup and continuously collect diagnostic information to support maintenance activities. For example, a remote maintenance console can request diagnostic information from a certain sensor. The DM interface is usually not time-critical.

**CP interface:** The *configuration and planning* interface allows the integration and setup of newly connected nodes. It is used to generate the “glue” in the network that enables the components of the network to interact in the intended way. Usually, the CP interface is not time-critical.

**RS interface:** The *real-time service* interface performs a periodic communication with predictable timing behavior among the smart transducer nodes. Communicated data is usually data from sensors and for actuators, but may also involve communication to and from processing nodes. This view employs sensors for producing periodic observations of real-time entities in the environment. For example, a temperature sensor periodically sends the observed and locally preprocessed sensor value to the temporal firewall of the master. Since in a time-triggered system the time interval between sensing the environment and presenting the sensor value at the temporal firewall [16] of the master is known a priori, it is possible to perform a feed-forward state estimation of the sensor value at the sensor node in such a way, that the delivered sensor value is a good estimate of the real-time entity’s actual state at the point in time of delivery.

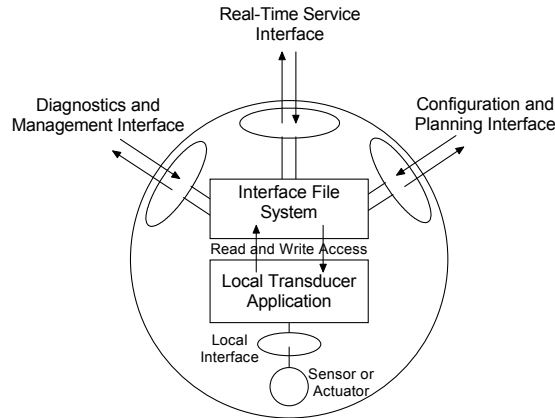

Figure 5: The three interface types to a Smart Transducer Node

**Naming and addressing.** Each transducer can contain up to 64 files in its IFS. An IFS file is an index sequential array of up to 256 records. A record has a fixed length of four bytes (32 bits). An IFS record is the smallest addressable unit within a smart transducer system. Every record of an IFS file has a unique hierarchical address (which also serves as the global name of the record) consisting of the concatenation of the cluster name, the logical name, the file name, and the record name.

Besides access via the master node, the local applications in the smart transducer nodes can also execute a clusterwide application by communicating directly with each other.

Figure 4 depicts the network view for such a clusterwide application. Note that the actual communication between physical nodes becomes transparent for the local applications since they exchange their data only via the IFS.

The IFS of each smart transducer node can be accessed via the RS interface, the DM interface, and the CP interface for different purposes. All three interface types are mapped onto the fieldbus communication protocol, but with different semantics regarding timing and data protection.

## 4.2 Fieldbus Communication Protocol

A time-triggered transport service following the specification of the STI has been implemented in the time-triggered fieldbus protocol TTP/A [19].

The bus allocation is done by a TDMA scheme. Communication is organized into rounds consisting of several TDMA slots. A slot is the unit for transmission of one byte of data. Data bytes are transmitted in a standard UART (Universal Asynchronous Receiver Transmitter) format. The first byte of a round is a message from the master called fireworks byte, since this message acts as a signal to all nodes for triggering a communication round.

The fireworks byte defines the type of the round. The protocol supports eight dif-

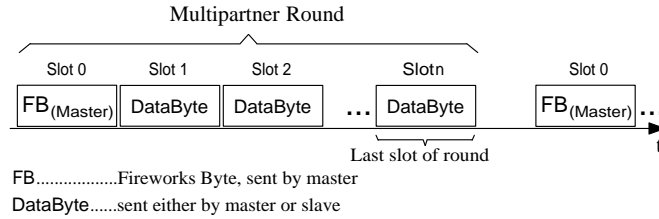

Figure 6: A TTP/A Multipartner Round

ferent firework bytes encoded in a message of one byte using a redundant bit code [20] supporting error detection.

Generally, there are two types of rounds:

**Multipartner (MP) round:** This round consists of a configuration dependent number of slots and an assigned sender node for each slot. The configuration of a round is defined in a data structure called “RODL” (ROund Descriptor List). The RODL defines which node transmits in a certain slot, the operation in each individual slot, and the receiving nodes of a slot. RODLs must be configured in the slave nodes prior to the execution of the corresponding multipartner round. An example for a multipartner round is depicted in Figure 6.

**Master/slave (MS) round:** A master/slave round is a special round with a fixed layout that establishes a connection between the master and a particular slave for accessing data of the node’s IFS, e. g., the RODL information. In a master/slave round the master addresses a data record in the hierarchical IFS address and specifies an action that is to be performed on that record. Supported actions are either reading, writing, or executing a record.

The master/slave rounds establish the DM and the CP interface to the transducer nodes. The RS interface is provided by periodical multipartner rounds. Master/slave rounds are scheduled periodically between multipartner rounds as depicted in Figure 7 in order to enable maintenance and monitoring activities during system operation without a probe effect.

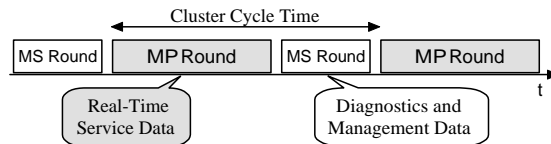

Figure 7: Recommended TTP/A Schedule

### 4.3 Integrating New Nodes into the Network

New transducer nodes that are connected to a cluster must be first configured before they can take part in the communication. A plug-and-play configuration consists of at least three tasks: to identify the new nodes, to obtain the documentation, and to download the configuration.

While new node identification is trivial for many networks, it is a difficult task in networks where deterministic behavior is achieved by master-slave addressing. The time-triggered smart transducer network uses a baptizing method for identification and configuration of new nodes that does not affect the determinism of the real-time communication of the network.

Until a logical name has been assigned to a node, it does not take part in the multi-partner rounds. The baptize algorithm [21] is executed by the master to see which nodes are connected to the TTP/A bus and to assign each of them a logical name, which is unique in the current TTP/A cluster.

This mechanism performs a binary search on all physical node names. A physical name is unique for every TTP/A node within the entire universe of TTP/A nodes. The identification of a new node takes 64 iterations. After finding the unique identifier of a node, a new logical name must be assigned to this node. The unique identifier of a node consists of a part that describes the generic node type (the *series* number) and a part that is used to distinguish between multiple instances of a transducer type (the *serial* number). The series number establishes a reference to the node's electronic datasheet containing the necessary information for integrating the node into the network. Datasheet information is uniformly represented in XML (eXtended Markup Language) and can be accessed via a CORBA service. The descriptions [22] consist of a cluster configuration part and a smart transducer description part (cf. device description approaches like electronic datasheets from IEEE 1452.2 [23], the IEC 62390 common automation device profile [24], or the Field Device Configuration Markup Language (FDCML) [25]).

Figure 8 depicts an example for accessing a node's datasheet via the CORBA network.

Since the configuration information is not directly stored at the node, there is no overhead on the smart transducers themselves.

## 5 Implementation Experiences

### 5.1 Smart Transducer Nodes

The presented time-triggered smart transducer interface has been implemented on several hardware platforms. The current segment of cheap 8-bit Microcontrollers is best suited for equipping sensors or actuators with a low-cost smart interface. We have made experiences with node implementations on the Atmel AVR family, the Microchip PIC and, especially for the master, the 32-bit ARM RISC microcontrollers.

Figure 9 depicts the hardware of a smart transducer implementation based on an Atmel AVR AT90S4433 microcontroller and an attached distance sensor. This type of controller offers 4K Byte of Flash memory and 128 Byte of SRAM. The physical network

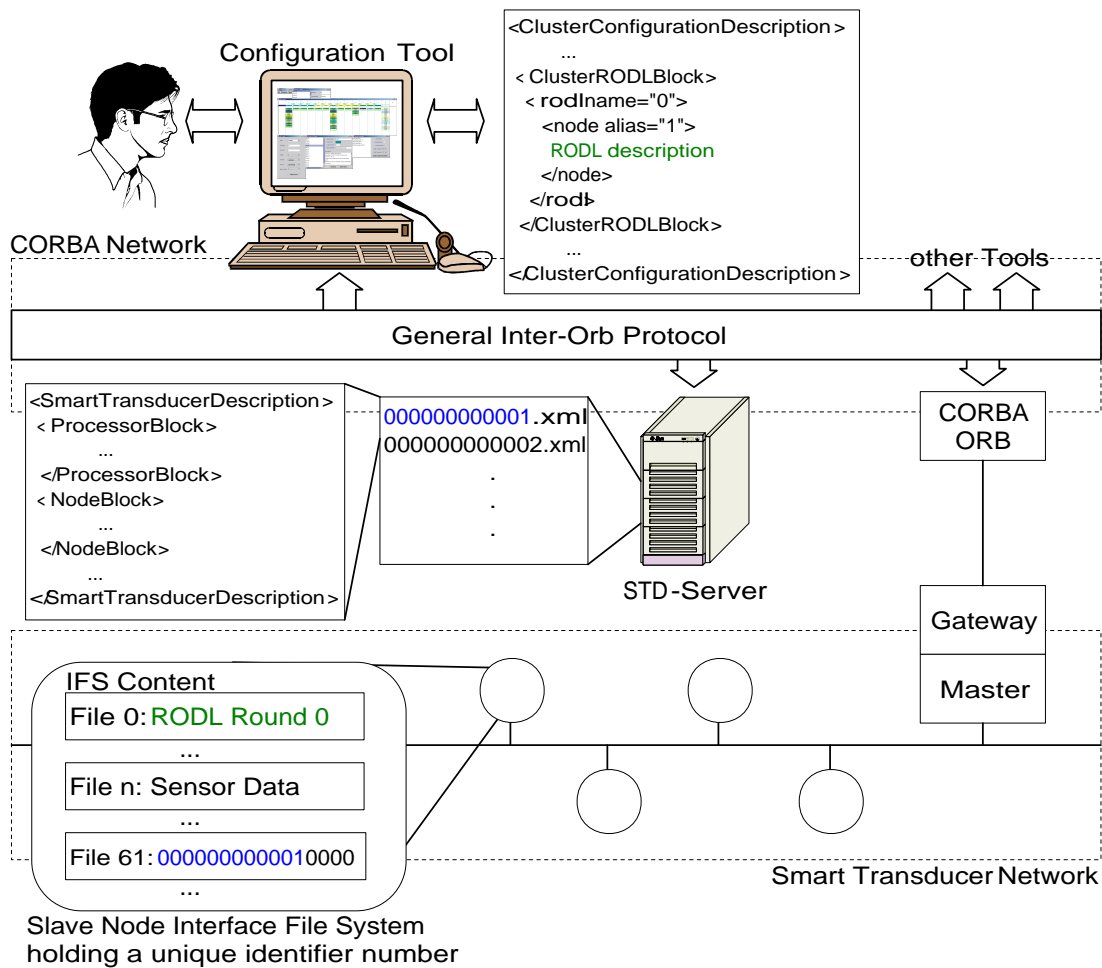

Figure 8: Accessing a node's datasheet

interface has been implemented by an ISO 9141 k-line bus, which is a single wire bus supporting a communication speed up to 50 kBps. The wires to the left of the photo contain the bus line and the power supply.

Table 3 gives an overview on the resource requirements for smart transducer implementations in Atmel AVR, Microchip PIC and ARM RISC microcontrollers. Since the time-triggered approach follows the *resource adequacy* principle [8, p.15], the performance and current workload at the controller does not influence the specified real-time behavior of the network, however, a controller that supports only a particular communication speed may not be used in networks that specify a higher communication rate. All three implementations held the timing requirements with a Baud Rate of 19.2 kbps. As physical layer, an ISO 9141 k-line bus had been used. For the Atmel AT90S4433 a maximum performance of 58.8 kbps had been tested on an RS485 physical layer.

The implementations on these microcontrollers show that due to the low hardware

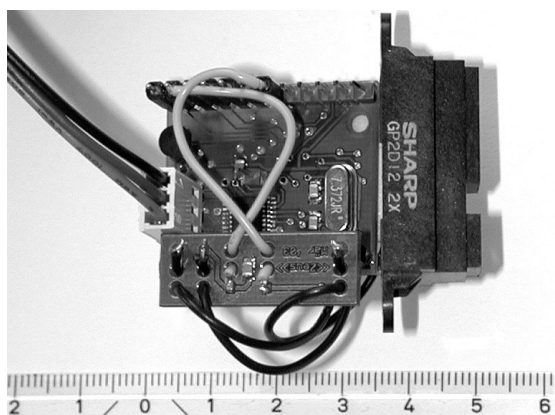

Figure 9: Smart transducer based on Atmel 4433 microcontroller with distance sensor attached (scale in centimeter)

| Microcontroller | Used Program Memory | Used RAM Memory | Clock Speed | Tested Baud Rate |
|-----------------|---------------------|-----------------|-------------|------------------|
| Atmel AT90S4433 | 2672B               | 63B             | 7.3728 MHz  | 58.8 kbps        |
| Microchip PIC   | 2275B               | 50B             | 8.0 MHz     | 19.2 kbps        |
| ARM RISC        | 8kB                 | n.k.            | 32.0 MHz    | 19.2 kbps        |

Table 3: Resource requirements and performance of time-triggered smart transducer interface implementations (from [26]).

requirements of the time-triggered smart transducer interface it should be possible to implement the protocol on nearly all available microcontrollers with similar features like the Atmel or Microchip microcontroller types, that is 4KB of Flash ROM and 128 Byte of RAM memory.

## 5.2 Application Case Study

As an example for a time-triggered smart transducer application, an autonomous mobile robot consisting of a four-wheeled model car with a smart transducer network for instrumenting a set of sensors, actuators and a navigation module, has been designed and implemented at the Vienna University of Technology.

The robot basically uses its sensors to locate objects in the driving direction and sets its steering and speeding actuators in order to pass the obstacles.

Figure 10 depicts the layout of the smart transducer nodes employed in the smart transducer network. Each of the 6 sensor nodes and 5 actuator nodes is implemented using an Atmel AT90S4433 microcontroller. Due to the larger memory requirements of the master/gateway and navigation applications, the master and navigation nodes are implemented on the more powerful microcontrollers AT90S8515 and ATmega128 from the Atmel AVR series.

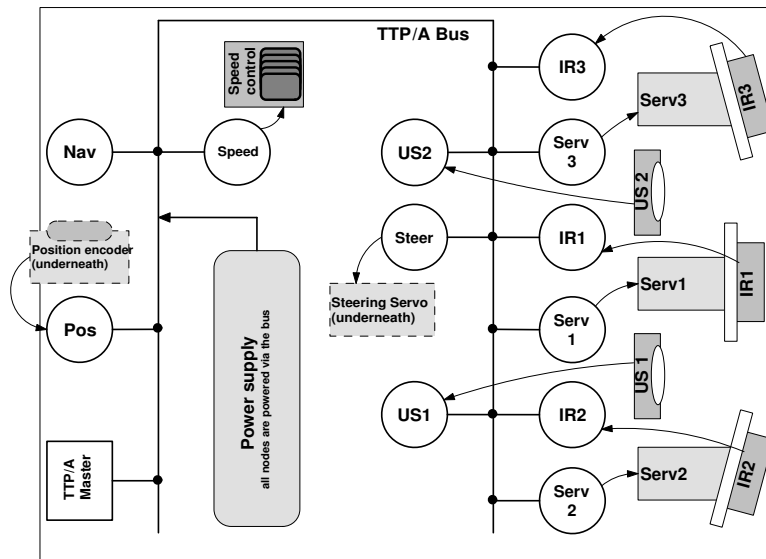

IR1 .....Middle infrared sensor      US1 .....Right ultrasonic sensor  
 IR2 Right forward infrared sensor      US2 ..... Left ultrasonic sensor  
 IR3 . Left forward infrared sensor      Pos .....Position encoder sensor  
 Serv1 .....Servo for IR1      Speed .... Speed control actuator  
 Serv2 .....Servo for IR2      Steer ...Steering control actuator  
 Serv3 .....Servo for IR3      Master ..... Synchronization and gateway  
 Nav Coordination and navigation

Figure 10: Smart transducer nodes on the autonomous robot

The smart transducer network has to fulfill several real-time tasks:

- The three infrared distance sensors IR1, IR2, and IR3 are mounted on servos Serv1, Serv2, and Serv3, which swivel the sensors for scanning the area in front of the car. Therefore, whenever a measurement from a distance sensor is read, the corresponding position of the respective servo must be exactly known in order to process the measurement correctly. The time-triggered schedule supports this coordination of servo position and measuring time and allows to minimize the time for a sensor sweep.
- The two ultrasonic sensors US1 and US2 are active sensors, i.e., they emit an ultrasonic ping when performing a measurement. Since both sensors face the same direction (the front of the car), the measurements must be coordinated in order to avoid mutual interference from the ultrasonic pings. This requirement can be conveniently fulfilled by defining an appropriate phase offset in the time-triggered schedule.
- The control of the robot's speed and the measurement of the covered distance

are done by a feedback control loop. Using standard control theory, the duration between measurement and setting a new speed value has to be constant and known. The time-triggered schedule fulfills this requirement at the outset.

Due to the predictable timing of the time-triggered system, the communication and action schedule could be implemented very tight and efficient, since no time is wasted for repeating messages in case of a busy channel, etc. The whole application runs sufficiently at a bus speed of 9600 bit/sec with a cluster cycle of 30 ms.

Each smart transducer node was designed independently from the overall application, most of them have been reused in other smart transducer applications. The robot has been used as a demonstrator for composable development in the DSoS project (Dependable Systems of Systems, IST Research Project IST-1999-11585). A report describing the robot implementation in detail can be found in [27].

## 6 Related Work

Real-time distributed networks for interconnection of sensors and actuators represent a well-established research area in the scientific community. Good overview papers on real-time communication systems including time-triggered communication are [28, 29, 30, 31].

However, there is not a lot of research literature that discusses the application of hard real-time capable time-triggered network interfaces for smart transducer networks. Most notable exceptions are the extension of the IEEE 1451 smart transducer standard with a time-triggered interface and, to a lesser extend, the LIN fieldbus, which has a time-triggered polling scheme.

### 6.1 IEEE 1451 with Time-Triggered Communication

An Irish research group has developed a time-triggered smart transducer system that incorporates the IEEE Smart Transducer Interface Standard (IEEE 1451.2) and a Time-Triggered Controller Area Network (TTCAN) communication protocol [32].

The IEEE 1452 Smart Transducer Interface Standard [33] proposes a point-to-point communication interface between a Smart Transducer Interface Module (STIM) and a Network-Capable Application Processor (NCAP). It supports a broad range of sensor and actuator models including those for buffered, time-triggered, data-sequence and event-sequence models. The standard uses an object representation for measured variables that resolves the problem of handling physical units. Additionally, it defines the Transducer Electronic Data Sheet (TEDS), which abstracts the properties of sensors and actuators enabling their dynamic definition via contextual information associated with data.

The IEEE 1451 standard comes also with a Transducer Independent Interface (TII) that supports the multiplexing of messages, however this TII does not support the hard real-time requirements regarding determinism. Therefore in this project the IEEE 1451 standard has been only partially implemented, since the TII protocol has been replaced by the deterministic time-triggered TTCAN protocol.



## 6.2 Local Interconnect Network (LIN)

LIN is basically a polling protocol, where a central master issues request messages to the slave nodes. The master node acts also as a gateway to a higher network. The slave nodes are smart transducers which are listening to specific messages in order to set a control value or to send a measured value on reply. The master issues request messages on a predefined schedule, while the slave nodes are not aware of a global time or the current state of the schedule. This simplifies the implementation of the slave nodes, but does not support coordinated actions like synchronized measurements.

Due to the polling principle (requesting a value involves the request message, a “thinking time” for the slave node and sending the reply message), the effective bandwidth of a LIN network supports only applications with low bandwidth requirements, such as less critical body electronic functions in cars.

## 7 Conclusion

The static structure of time-triggered communication is an advantage and a disadvantage at the same time. On the one hand, it enables guaranteed deterministic timing and supports hard real-time constraints, on the other hand, it makes it difficult to efficiently access sparsely changing values or maintenance facilities. In the proposed architecture for time-triggered smart transducer networks, this problem has been overcome by a separate implementation of virtual communication interfaces: the real-time service interface provides the timely communication of fast changing real-time values, like measurements or control values, while the configuration and planning and the diagnostics and management interfaces allows for flexible access to schedules, sensor logs, trimming and calibration parameters, etc. Moreover, since the time-triggered communication does not need to explicitly address frames in their messages and avoids collisions by design, it is much more efficient for periodic data exchange than event-triggered or polling protocols.

The implementation of time-triggered smart transducers on several platforms has shown that hard real-time requirements can be fulfilled with resources of typical low-cost 8-bit microcontrollers. Implementations of various sensors and actuators have proven to be efficient and reusable.

Recent work in adapting standards like IEEE 1451 to time-triggered communication interfaces has underlined the relevance and appropriateness of the time-triggered approach for smart transducer networks.

## 8 Acknowledgments

I would like to thank the anonymous reviewers for their valuable comments on an earlier version of this paper. Furthermore thanks to Wolfgang Haidinger and Stefan Pitzek for proofreading the paper. This work was supported in part by the European IST project DECOS (Dependable Embedded Components and Systems) under contract number IST-511764 and the Austrian FIT-IT project SDSTI under contract No 808693.

## References

- [1] L. H. Eccles. A brief description of IEEE P1451.2. *Sensors Expo*, May 1998.
- [2] J. Gait. A probe effect in concurrent programs. *Software Practice and Experience*, 16(3):225–233, March 1986.
- [3] C. E. McDowell and D. P. Helmbold. Debugging concurrent programs. *ACM Computing Surveys*, 21(4):593–622, December 1989.
- [4] M. Bengtsson. Condition based maintenance system technology - Where is development heading? In *Proceedings of the 17th European Maintenance Congress*, Barcelona, Spain, May 2004.
- [5] B. Parhami. Optimal algorithms for exact, inexact, and approval voting. *Twenty-Second International Symposium on Fault-Tolerant Computing, 1992. FTCS-22. Digest of Papers.*, pages 404–411, July 1992.
- [6] W. Elmenreich. An introduction to sensor fusion. Technical Report 47/2001, Technische Universität Wien, Institut für Technische Informatik, Vienna, Austria, 2001.
- [7] H. Kopetz and G. Bauer. The Time-Triggered Architecture. *Proceedings of the IEEE*, 91(1):112 – 126, January 2003.
- [8] H. Kopetz. *Real-Time Systems: Design Principles for Distributed Embedded Applications*. Kluwer Academic Publishers, 1997.
- [9] S. Poledna. *Replica Determinism in Fault-Tolerant Real-Time Systems*. PhD thesis, Technische Universität Wien, Institut für Technische Informatik, Vienna, Austria, 1994.
- [10] Audi AG, BMW AG, DaimlerChrysler AG, Motorola Inc. Volcano Communication Technologies AB, Volkswagen AG, and Volvo Car Corporation. LIN specification and LIN press announcement. SAE World Congress Detroit, <http://www.lin-subbus.org>, 1999.
- [11] N. Suri, M.M. Hugue, and C.J. Walter. *Advances in Ultra-Dependable Distributed Systems*. IEEE Press, 1995.
- [12] H. Kopetz. On the fault hypothesis for a safety-critical real-time system. In *Proceedings of the Automotiove Workshop San Diego*, CA, USA, January 2004.
- [13] Object Management Group (OMG). *Smart Transducers Interface Request for Proposal*, December 2000. Available at <http://www.omg.org> as document orbos/2000-12-13.

- [14] Object Management Group (OMG). *Smart Transducers Interface V1.0*, January 2003. Specification available at <http://doc.omg.org/formal/2003-01-01> as document ptc/2002-10-02.
- [15] H. Kopetz, M. Holzmann, and W. Elmenreich. A universal smart transducer interface: TTP/A. *International Journal of Computer System Science & Engineering*, 16(2):71–77, March 2001.
- [16] H. Kopetz and R. Nossal. Temporal firewalls in large distributed real-time systems. *Proceedings of the 6th IEEE Workshop on Future Trends of Distributed Computing Systems (FTDCS '97)*, pages 310–315, 1997.
- [17] W. Elmenreich, W. Haidinger, and H. Kopetz. Interface design for smart transducers. In *IEEE Instrumentation and Measurement Technology Conference*, volume 3, pages 1642–1647, Budapest, Hungary, May 2001.
- [18] A. Ran and J. Xu. Architecting software with interface objects. In *Proceedings of the 8th Israeli Conference on Computer-Based Systems and Software Engineering*, pages 30–37, 1997.
- [19] H. Kopetz et al. Specification of the TTP/A protocol. Technical report, Technische Universität Wien, Institut für Technische Informatik, Vienna, Austria, September 2002. Version 2.00.
- [20] W. Haidinger and R. Huber. Generation and analysis of the codes for TTP/A fireworks bytes. Research Report 5/2000, Technische Universität Wien, Institut für Technische Informatik, Vienna, Austria, 2000.
- [21] W. Elmenreich, W. Haidinger, P. Peti, and L. Schneider. New node integration for master-slave fieldbus networks. In *Proceedings of the 20th IASTED International Conference on Applied Informatics (AI 2002)*, pages 173–178, February 2002.
- [22] S. Pitzek and W. Elmenreich. Configuration and management of a real-time smart transducer network. In *Proceedings of the 9th IEEE International Conference on Emerging Technologies and Factory Automation (ETFA 2003)*, Lisbon, Portugal, September 2003.
- [23] Institute of Electrical and Electronics Engineers, Inc. *IEEE Std 1451.2-1997, Standard for a Smart Transducer Interface for Sensors and Actuators - Transducer to Micro-processor Communication Protocols and Transducer Electronic Data Sheet (TEDS) Formats*, 1997.
- [24] International Electrotechnical Commission,. *IEC TR 62390, Common automation device Profile guideline*, 2005. First edition 2005-01.
- [25] FDCML. *Field Device Configuration Markup Language FDCML 2.0 Specification*, 2005. Version 1.0, Available at <http://www.fdcml.org>.

- [26] C. Trödhandl. Architectural requirements for TTP/A nodes. Master's thesis, Technische Universität Wien, Institut für Technische Informatik, Vienna, Austria, 2002.
- [27] W. Elmenreich, W. Haidinger, H. Kopetz, T. Losert, R. Obermaisser, M. Paulitsch, and C. Trödhandl. Initial demonstration of smart sensor case study. *DSoS Project (IST-1999-11585) Deliverable PCE3*, April 2002.
- [28] J. Rushby. A comparison of bus architectures for safety-critical embedded systems. Technical Report NASA/CR2003212161, National Aeronautics and Space Administration, Langley Research Center, March 2003.
- [29] R. Zurawski, editor. *The Industrial Communication Technology Handbook*. CRC Press, Boca Raton, FL 33431, USA, 2005.
- [30] J. Berge and S. Mitschke. Building better open networks using foundation fieldbus and OPC. *Sensors Magazine*, February 2000.
- [31] J. R. Jordan. *Serial Networked Field Instrumentation*. John Wiley & Sons, 1995.
- [32] P. Doyle, D. Heffernan, and D. Duma. A time-triggered transducer network based on an enhanced IEEE 1451 model. *Microprocessors & Microsystems Journal*, December 2002.
- [33] P. Conway, D. Heffernan, B. O'Mara, D. P. Burton, and T. Miao. IEEE 1451.2: An interpretation and example interpretation. In *Proceedings of the Instrumentation and Measurement Technology Conference*, pages 535–540, Baltimore, MD, USA, May 2000.