

BODY SENSOR NETWORK – A WIRELESS SENSOR PLATFORM FOR PERVASIVE HEALTHCARE MONITORING

Benny P.L. Lo, Surapa Thiemjarus, Rachel King and Guang-Zhong Yang*

Abstract

With recent advances in wireless sensor networks and embedded computing technologies, miniaturized pervasive health monitoring devices have become practically feasible. In addition to providing continuous monitoring and analysis of physiological parameters, the recently proposed Body Sensor Networks (BSN) incorporates context aware sensing for increased sensitivity and specificity. To facilitate research and development in BSN and multi-sensor data fusion, a BSN hardware development platform is presented. With its low power, flexible and compact design, the BSN nodes provide a versatile environment for wireless sensing research and development.

1. Introduction

Cardiovascular disease is the main cause of death in the UK and it accounts for 39% of all death each year. Among patients who had heart attacks, about 30% of them died even before reaching to the hospital [5]. Although heart attack can happen suddenly without apparent indications, cardiac rhythm disturbances can often be found before the event. They can potentially be used as the precursor to major cardiac episodes [3]. Currently, ECG (Electrocardiogram) Holter monitoring is the most widely used technique for providing ambulatory cardiac monitoring for capturing rhythm disturbances. A traditional Holter monitor can record up to 24 hours of ECG signals, and the recorded data is subsequently retrieved and analyzed by a clinician. Due to the short duration involved and the unknown context within which the ECG signal is captured, reliable interpretation of the recorded data is always a challenge. To address these drawbacks, some more advanced ECG monitoring systems are emerging. They can also detect and signal a warning in real-time if any adverse event is captured [7]. Recent research has also focused on the development of wireless sensor networks (WSN) and pervasive monitoring systems for cardiac patients. For example, a number of wearable systems have been proposed with integrated wireless transmission, GPS (Global Positioning System) sensor, and local processing [2,4,6,10]. Commercial systems are also becoming available. For example, CardioNet provides a remote heart monitoring system where ECG signals are transmitted to a PDA (Personal Digital Assistant) and then routed to the central server by using the cellular network [6]. Pentland recently presented the wearable MIThril system where ECG data, GPS position, skin temperature and galvanic skin response can be captured by a PDA [4].

* Department of Computing, Imperial College London, South Kensington Campus
180 Queen's Gate, London, SW7 2AZ, United Kingdom.
{benlo, st01, rck, gzy}@doc.ic.ac.uk

Thus far, most of the WSN hardware platforms are designed for network research, environment monitoring or tracking applications, such as Berkeley's Mica2 and Telos, ETH's BTnodes, Intel's iMote and UCC's DSYS25[1,10,11,12]. Although there are a number of context aware sensing platforms such as the SmartITs and the MITes [8,9], due to the integrated sensor design, the incorporation of physiological sensor will require major redesign of the hardware platform. The lack of a flexible operating system also hinders the extension of the platform for the research community. To facilitate the research and development of BSN, a BSN hardware platform is designed and developed. With its stackable design, different type of sensors can easily be integrated. By adopting the IEEE 802.15.4 standards, sufficient bandwidth is available for demanding continuous physiological and context sensing. The basic structure of BSN is shown in Fig. 1, where wireless physiological sensors are used to measure the status of the patient. However, relying only on the physiological data can often involve false detections due to motion artefacts and changes in physiological/emotional stress. For example, sudden heart rate changes may be due to exercise rather than arrhythmia. To capture clinically relevant episodes, the context aware sensors are incorporated into the design of the BSN, and the local PDA is used for multi-sensor data fusion before transmitting the data to the central server to minimize the bandwidth usage.

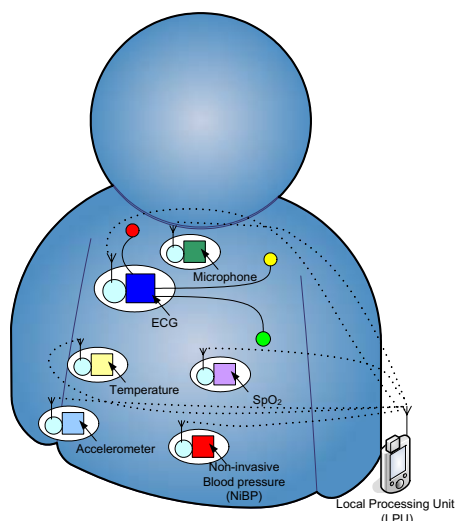

Fig.1. Body Sensor Network Design

2. BSN Architectural Design

Fig. 2 illustrates the basic structure the BSN node (*left*) and its architectural design (*right*). The BSN node uses Texas Instrument (TI) MSP430 16-bit ultra low power RISC processor with 60KB+256B Flash memory, 2KB RAM, 12-bit ADC and 6 analog channels (connecting up to 6 sensors). The wireless module has a throughput of 250kbps with a range over 50m. In addition, 512KB serial flash memory is incorporated in the BSN node for data storage or buffering. The BSN node runs TinyOS by U.C. Berkeley, which is a small, open source and energy efficient sensor board operating system. It provides a set of modular software building blocks, of which designers could choose the components they require. The size of these files is typically as small as 200 bytes and thus the overall size is kept to a minimum. The operating system manages both the hardware and the wireless network—taking sensor measurements, making routing decisions, and controlling power dissipation. By using the ultra low power TI microcontroller, the BSN node requires only 0.01mA in active mode and 1.3mA when performing computation intensive calculation like a FFT.

With a size of 26mm, the BSN node is ideal for developing wearable biosensors. In addition, the stackable design of the BSN node and the available interface channels ease the integration of different sensors with the BSN node. Together with TinyOS, the BSN node can significantly cut the development cycle for wireless biosensor development.

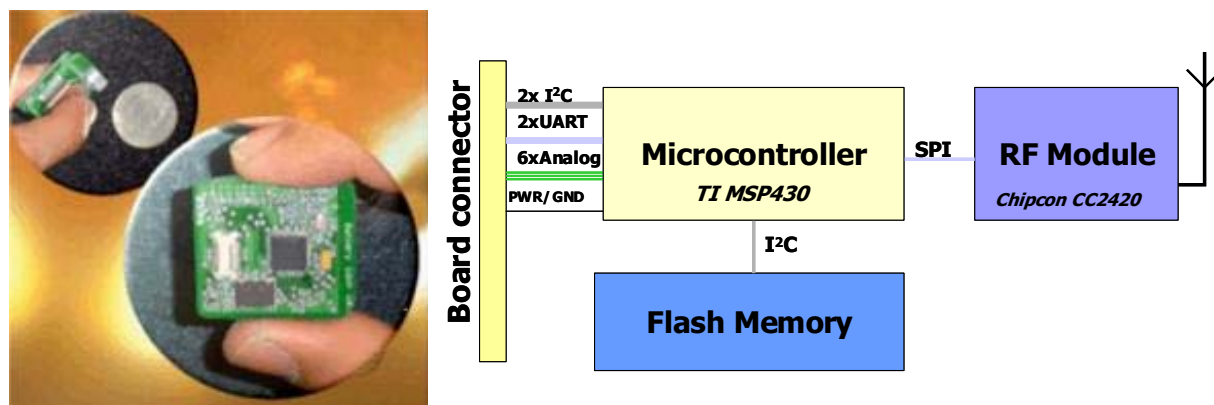

Fig. 2. BSN Node (*left*) and its architectural design (*right*)

3. Prototype and Demonstration

With the proposed BSN architecture, a number of wireless biosensors including 3-lead ECG, 2-lead ECG strip, and SpO₂ sensors have been developed (Fig. 3a-c). To facilitate the incorporation of context information, context sensors including accelerometers, temperature and humidity sensors are also integrated to the BSN node. Furthermore, a compact flash BSN card is developed for PDAs, where sensor signals can be gathered, displayed and analyzed by the PDA, as shown in Fig. 3d. Apart from acting as the local processor, the PDA can also act as the router between the BSN nodes and the central server, where all sensor data collected will be transmitted through a WiFi/GRPS network for long-term storage and trend analysis.

The proposed demonstration will illustrate the latest design of the BSN nodes and their interoperability with other WSN platforms such as MicaZ and Telos. It will also provide a unique hands-on experience of using the BSN nodes for constructing wireless sensing daughter-boards during the exhibition. To establish the key features of the proposed platform, a live demonstration will be set up during the exhibition where prototype physiological and context awareness sensors will be worn to illustrate a clinical scenario of continuous patient monitoring under normal physiological activities. In addition, we will demonstrate the sensor fusion environment by using the real-time central database for trend analysis and data mining. Furthermore, we will also demonstrate our newly developed STSOM and Bayesian context detection framework for outlining the strength and research challenges of context aware sensing.



Fig. 3. (a) Wireless 3-lead ECG sensor, (b) ECG Strap, (c) SpO2 sensor, and the PDA base station.

4. References

- [1] BARROSO A., BENSON J., MURPHY T., ROEDIG U., SREENAN C., BARTON J., BELLIS S., O'FLYNN B. and DELANEY K., The DSYS25 Sensor Platform, Proceedings of the ACM SenSys '04, 2004.
- [2] LISZKA K.J., MACKIN M.A., LICHTER M.J., YORK D.W., PILLAI D. and ROSENBAUM D. S., Keeping a Beat on the Heart, IEEE Pervasive Computing, Oct-Dec 2004; 3(4):42-49.
- [3] PANIDIS IP and MORGANROTH J., Sudden death in hospitalized patients: cardiac rhythm disturbances detected by ambulatory electrocardiographic monitoring, J Am Coll Cardiol. 1983 Nov; 2(5):798-805.
- [4] PENTLAND A., Healthwear: Medical Technology Becomes Wearable, IEEE Computer, May 2004; 37(5): 42-49.
- [5] PETERSEN S., PETO V. and RAYNER M., Coronary heart disease statistics 2004, British Heart Foundation, June 2004.
- [6] ROSS P.E., Managing Care Through The Air, IEEE Spectrum, Dec 2004; 14-19.
- [7] STANDING P., DENT M., CRAIG A. and GLENVILLE B., Changes in referral patterns to cardiac out-patient clinics with ambulatory ECG monitoring in general practice, The British Journal of Cardiology, June 2001;8 (6): 396-398.
- [8] TAPIA E.M., MARMASSE N., INTILLE S.S. and LARSON K. MITes: Wireless Portable Sensors for Studying Behavior, Proceedings of the UbiComp 2004, Sept 2004.
- [9] <http://particle.teco.edu/>
- [10] <http://www.btnode.ethz.ch/>
- [11] <http://www.intel.com/research/exploratory/motes.htm>
- [12] <http://www.tinyos.net>