

Environmental Product Declaration for Precast Concrete Products



Legacy Precast LLC.

8725 FM 362
Brookshire, Texas 77423
(855) 442-5502
www.legacyprecast.com

Environmental Product Declaration Precast Concrete Products

Product: Structural Precast Double Tees

(per ISO 14025 and ISO 21930)

About Legacy Precast LLC

A management team with more than 150 years of experience. The experts at Legacy Precast can save you time and money; from precast parking structures to office buildings, industrial/institutional projects, schools and much more, we have you covered. At our precast/prestress concrete manufacturing plant, our main focus is providing our customers with the most cost-effective solutions to meet their precast concrete needs, and to make sure that we respect our professional relationship by delivering quality products and services on time, on schedule, and within budget. Maintaining our reputation as cost-competitive and efficient is important to us. We work to keep our staff team-oriented and willing to go above and beyond to provide the service and precast systems you need. After successfully completing our PCI Plant audits, we were granted PCI Plant Certification in 2014 and our PCI Architectural Certification in 2018.

Proudly serving the Great State of Texas, including Houston, Dallas, Austin, & San Antonio Metro Markets.

Author of the Life Cycle Assessment: D. Green - Master Builders Solutions US LLC

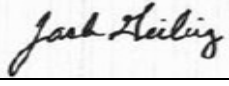

**Certified
Environmental
Product Declaration**
www.nsf.org

EPD Information			
Program Operator		NSF Certification, LLC	
Declaration Holder		Legacy Precast LLC	
Product:	Date of Issue	Period of Validity	Declaration Number
Double Tee	June 3, 2022	5 Years	EPD10690
Independently verification of the declaration and data, according to ISO 21930:2017 and ISO 14025:2006 by NSF Certification, LLC.		 Tony Favilla afavilla@nsf.org	
Internal	<input checked="" type="checkbox"/> External		
This life cycle assessment was independently verified in accordance with ISO 14044 and the reference PCR.		 Jack Geibig jgeibig@ecoform.com	
LCA Information			
Basis LCA		Life Cycle Assessment Manager for Concrete Environmental Product Declaration June 2019	
LCA Preparer		David Green Master Builders Solutions US LLC david.green@mbcc-group.com	
This life cycle assessment was critically reviewed in accordance with ISO 14044 by:		Jack Geibig - Ecoform jgeibig@ecoform.com	

North America PCR Information	
Program Operator	NSF International
Reference PCR	ISO 21930:2017 Sustainability in Building Construction – Environmental Declaration of Building Products serves as the core PCR. NSF PCR for Precast Concrete v2 serves as the sub-category PCR.
Date of Issue	May 1, 2021
Sub-category PCR review was conducted by:	Thomas P. Gloria, Ph.D, Industrial Ecology Consultants, t.gloria@industrial-ecology.com
EPD Software Tool	
LCA Software & Version Number	One Click LCA 2021
LCI Database & Version Number	One Click LCA, Ecoinvent 3.6
For additional explanatory material:	Jay Cariveau jcariveau@LegacyPrecast.com
Additional environmental activities	

ENVIRONMENTAL PRODUCT DECLARATION: DETAILED VERSION

Product Scope



This declaration and its LCA study are relevant to precast concrete products manufactured by Legacy Precast LLC for the state of Texas. As the owner of the declaration, Legacy Precast LLC may be liable for the underlying information and evidence. The program operator shall not be liable with respect to manufacturer information, life cycle assessment data and evidence.

Product Description



Typical Double Tees in Storage

This EPD includes representative products developed from the Legacy Precast portfolio of products manufactured at its facility located in Brookshire, Texas. This Environmental Product Declaration (EPD) covers structural precast double tees for markets throughout Texas including Houston, Dallas, Austin, and the San Antonio metro areas. The UNCPC Class for this product is 37550 and CSI Division 03 40 00. The primary audiences for structural precast products are engineers, designers, architects, and project owners.

The results for this EPD are based on the full year 2020 of operational data and current raw materials and suppliers. All production is completed at the Brookshire, Texas facility.

Product Specification and Application

The products evaluated for the EPD meet the following technical specifications:

- ASTM C-150: Portland cement
- ASTM C-33/33M: Concrete aggregates
- ASTM C-94: Ready-Mix Concrete
- ASTM C618: Supplementary cementitious materials – fly ash
- ASTM C494 and ASTM C60: Admixtures

Application

Legacy Precast structural double tees are used in various building systems including parking garages, industrial buildings, data centers, office buildings, schools, and other commercial/industrial structures. Guidance on the safe and correct installation, use and disposal of the product is available from Legacy Precast LLC.

Technical Data

The technical specifications for the product(s) represented by this EPD are shown here.

Table 1: Product Technical Details – Double Tee

Precast Concrete Parameter	Range and Additional details
Compressive Strength, psi prior to release	3,200 to 5,900
Compressive Strength, psi after 7 days	4,000 to 5,500
Compressive Strength, psi after 28 days	5,000 to 6,500 plus
Reinforcement	Embeds, rebar and strand per plans and details
Misc. plates and embeds	As required per plans and details

Flow Diagram

The life cycle assessment (LCA) is a cradle-to-gate study. An overview of the system boundaries is shown in Figure 1.

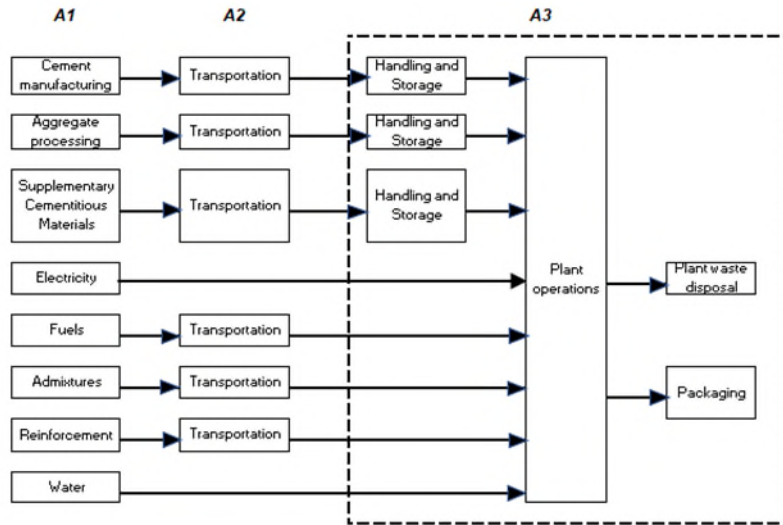

Figure 1: Cradle-to-gate precast concrete plant system boundary

Manufacturing

Legacy Precast, LLC manufacturers precast, prestressed concrete structural and architectural components for various building systems such as parking garages, industrial buildings, data centers, office buildings, schools, and other commercial/industrial structures. All products are manufactured using a variety of steel and/or wood molds and forming. Steel embeds and assemblies are fabricated on site and placed in the forms along with rebar and prestressing

strand reinforcement per the contract drawings. Concrete mixture is comprised of cement, supplementary cementitious materials, sand, aggregate and water per the project concrete mix designs. Additional admixtures are utilized to improve performance, durability and to keep material in proper suspension prior to concrete placement. The concrete is batched, placed in the forms, and stripped from the forms after achieving appropriate release strengths. The concrete continues to cure and harden to design strength and beyond. The products are placed in storage and scheduled for transportation and installation. The product does not require any packaging material.

This EPD is based on a cradle-to-gate system boundary deemed appropriate based on the North American PCR. Reference service life is not relevant due to the cradle-to-gate boundary conditions.

Life cycle stages that are not included in this EPD are A4 (Transportation to the Construction Site), A5 (Construction and Installation Process), B1-B7 (Use Phase) and C1-C4 (End of Life Stage).

Material Composition



The precast double tees and upstream materials covered by this Environmental Product Declaration conform to the appropriate ASTM standards as described in NSF International PCR for Precast Concrete, UNSPSC code 37550 and CSI Specification Section 03 40 00. The raw materials for the product are obtained from various suppliers in the United States. The general composition is represented in Table 2:

Table 2: Product Material Composition

<i>Material</i>	<i>Amount</i>
Sands	40 – 50 %
Aggregates	30 – 40 %
Binders	10 - 20 %
SCMs	1 – 10%
Water	1 - 10%
Reinforcement and hardware	2 - 8%
Admixtures	<1%

The product does not contain materials that are listed in the REACH “Candidate List of Substances of Very High Concern for Authorization”.

This sub-category PCR recognizes fly ash, silica fume and granulated blast furnace slag as recovered materials and thus the environmental impacts allocated to these materials are limited to the treatment and transportation required to use as a precast concrete material input.

Production

Health and safety measures with potential impact to human health during manufacturing are to be consistently adhered to per regional regulatory requirements. Initiatives must be undertaken to minimize or eliminate potential impacts to the environment based on the use of best practices including engineered controls. Fresh, plastic concrete must be managed in accordance with local regulations. Hardened concrete is an inert product and can be recycled subject to local regulations. If disposed under the European waste catalogue, the waste code 17-01-01 for non-hazardous concrete and 17-01-06 for concrete containing hazardous substances is applicable. Any substances with hazardous and toxic properties that may be of concern to human health and/or the environment are provided in corresponding SDS documents based on regulatory requirements.



Declared Unit

The declared unit is 1,000 kg of Legacy Precast concrete produced as a double tee for commercial applications with a specified compressive strength range of 5,000 to 6,500⁺ psi (34 to 45⁺ MPa) at 28 days.



Life Cycle Assessment (LCA)

The LCIA results are relative expressions and do not predict impacts on category endpoints, the exceeding of thresholds, safety margins or risks.

A summary of the life cycle stages **included** in the EPD are as follows:

I. Raw Material Supply (A1): Extraction and processing of raw materials, including fuels used in raw material production and transport within the manufacturing process (A3).

Constituent materials in precast concrete may include, but are not limited to cement, supplementary cementitious materials, aggregates, reinforcement, insulation, admixtures, and hardware.

II. Transportation (A2): Average or specific transportation of raw materials (including recovered materials) from an extraction site, manufacturing source or distribution terminal to the manufacturing site including empty backhauls and transportation to interim distribution centers or terminals.

III. Manufacturing (A3): Including the product and all energy and materials required and all emissions and wastes produced. This includes but is not limited to energy use throughout the process, average or specific transportation, fresh water for batch and processes, packaging including transportation, transportation to manage pre-consumer wastes and unutilized products from manufacturing and energy recovery of pre-consumer wastes and by-products from production.

Table 3: Life Cycle Stages

Product Stage			Construction Process Stage		Use Stage							End of Life Stage				Benefits and loads beyond the system
Raw material supply	Transport	Manufacturing	Transport from the gate to the site	Assembly	Use	Maintenance	Repair	Replacement	Returbishment	Operational energy use	Operational water use	Deconstruction and/or demolition	Transport	Waste processing	Disposal	Reuse, recovery, recycling potential
A1	A2	A3	A4	A5	B1	B2	B3	B4	B5	B6	B7	C1	C2	C3	C4	D
X	X	X	MND	MND	MND	MND	MND	MND	MND	MND	MND	MND	MND	MND	MND	MND

DESCRIPTION OF THE SYSTEM BOUNDARY (X = INCLUDED IN LCA; MND = MODULE NOT DECLARED)

The processes **excluded** from the EPD are as follows:

- I. Production, manufacture and construction of manufacturing capital goods and infrastructure.
- II. Production and manufacture of production equipment, delivery vehicles, and laboratory equipment.
- III. Formwork.
- IV. Personnel-related activities (travel, furniture, office supplies).
- V. Energy and water use related to company management and sales activities that may not be located either within the factory site or at another location.

A summary of the limitations of this EPD include:

This EPD does not report all the environmental impacts due to manufacturing of the product, but rather reports the environmental impacts for those categories with established life cycle assessment-based methods to track and report. Unreported environmental impacts include (but are not limited to) factors attributable to human health, land use change and habitat destruction.

This EPD was calculated using industry average cement data. Cement LCA impacts can vary depending upon manufacturing processes, efficiency, and fuel sources by as much as 50% for some environmental impact categories. Cement accounts for as much as 90% of the impacts of the concrete mix(es) included in this EPD and thus manufacturer specific cement impacts could result in variation of as much as 45%.

This EPD reports the results of an LCA for 'cradle to gate' analysis and is intended for business-to-business communications. Thus, declarations themselves are not comparative assertions, defined as an environmental claim regarding the superiority or equivalence of one product versus a competing product that performs the same function. An EPD does not make any statements that the product covered by the EPD is better or worse than any other product.

To assess the local impacts of product manufacturing, additional analysis is required. Life cycle impact assessment results are relative expressions and do not predict impacts on category endpoints, the exceeding of thresholds, safety margins or risks.

Environmental Product Declaration - Precast Concrete 6/03/2022

Comparability:

EPDs may enable comparison between products but do not themselves compare products, as stated in ISO 14025 Sections 4 and 6.7.2. Environmental declarations from different programs (ISO 14025) may not be comparable. EPDs are comparable only if they use the same PCR (or sub-category PCR where applicable), include all relevant information modules and are based on equivalent scenarios with respect to the context of construction works. This PCR allows EPD comparability only when the same functional requirements between products are ensured and the requirements of ISO 21930:2017 §5.5 are met. However, variations and deviations are possible. Example of variations: different LCA software and background LCI datasets may lead to different results for the life cycle stages declared.

This EPD covers only cradle-to-gate impacts of precast concrete products using a declared unit and the results cannot be used to compare between products.

Allocation:

During the production of precast concrete products, co-products are not introduced into the mixture designs. The product category rules for this EPD recognize fly ash, silica fume and slag as recovered materials and thus the environmental impacts allocated to these materials are limited to the treatment and transportation required to use as a concrete material input.

Cut-off Criteria:

All material and energy flows known or suspected to release substances into the air, water or soil in quantities that contribute significantly to any of the indicators in ISO 21930 are included. In cases where there is insufficient input data for a unit process or data gaps, the cut-off criteria used is 1% of renewable primary resources (energy), 1% of non-renewable primary resource (energy) usage, 1% of the total mass input of that unit process and 1% of environmental impacts. The total of neglected input flows per module does not exceed 5%.

Scenarios:

Per the sub-category PCR, scenarios are not required to be reported for cradle-to-gate EPDs.



LCA: Interpretation and Results

The following tables provide the results of the LCA and the environmental parameters from the LCA for one (1) metric tonne of precast concrete product. The environmental impacts are based on the TRACI v2.1 characterization factors and NSF International PCR for Precast Concrete.

Note: Some LCA impact categories and inventory items are still under development and can have high levels of uncertainty. To promote uniform guidance on the data collection, calculation, and reporting of results, the ACLCA methodology (ACLCA 2019) was used. Use caution when interpreting data in these categories.

- Renewable primary energy resources as energy (fuel) (PERE)
- Renewable primary resources as material (PERM)
- Non-renewable primary resources as energy (fuel) (PENRE)
- Non-renewable primary resources as material (PENRM)
- Secondary Materials (SM)
- Renewable secondary fuels (RSF)
- Non-renewable secondary fuels (NRSF)
- Recovered energy (RE)
- Abiotic depletion potential for non-fossil mineral resources (ADPelements)
- Hazardous waste disposed
- Non-hazardous waste disposed
- High-level radioactive waste
- Intermediate and low-level radioactive waste
- Components for reuse
- Materials for recycling
- Materials for energy recovery
- Recovered energy exported from the product system.

Additional note: not all LCA datasets for upstream materials include these impact categories and thus, results may be incomplete. Use caution when interpreting data in these categories.

Removals and emissions associated with biogenic carbon content for products or packaging and emissions from carbonation or removals from calcination are not included in this study based on a cradle-to-gate approach and the absence of biobased materials in the declared unit. Renewable and non-renewable sources are not used for energy generation in any precast concrete production processes and are therefore not included in the information modules.

Environmental Product Declaration - Precast Concrete 6/03/2022

Note: emerging LCA impact categories and inventory items are still under development and can have high levels of uncertainty that preclude international acceptance pending further development. Use caution when interpreting data in these categories.

Core mandatory impact indicators per 1 metric tonne of precast concrete product - TRACI v 2.1				
	A1	A2	A3	Total
Global warming potential (GWP 100) [kg CO ₂ e]	1.60E+02	9.36E+00	2.03E+00	1.71E+02
Ozone depletion potential (ODP) [kg CFC 11e]	6.07E-06	2.27E-06	1.46E-06	9.81E-06
Acidification potential (AP) [kg SO ₂ e]	3.57E-01	3.52E-02	1.32E-02	4.05E-01
Eutrophication potential (EP) [kg Ne]	5.56E-02	4.90E-03	2.25E-03	6.26E-02
Photochemical smog creation potential (POCP) [kg O ₃ e]	6.78E+00	7.57E-01	1.51E-01	7.68E+00
Additional optional impact indicators				
	A1	A2	A3	Total
Abiotic depletion potential for non fossil resources (ADPelements) [kg Sbe]	2.73E-02	1.59E-04	3.62E-06	2.75E-02
Abiotic depletion potential for fossil resources (ADPfossil) [MJ]	9.88E+02	1.45E+02	9.93E+01	1.23E+03
Results of the LCA - resource use: 1 metric tonne of precast concrete product				
	A1	A2	A3	Total
Renewable primary energy as energy carrier (PERE) [MJ]	6.87E+01	1.56E+00	1.79E+00	7.20E+01
Renewable primary energy resources used as raw materials (PERM) [MJ]	5.02E-03	0.00E+00	0.00E+00	5.02E-03
Total use of renewable primary energy resources (PERT) [MJ]	6.87E+01	1.56E+00	1.79E+00	7.20E+01
Non-renewable primary energy as energy carrier (PENRE) [MJ]	1.11E+03	1.45E+02	9.93E+01	1.36E+03
Non-renewable primary energy resources used as raw materials (PENRM) [MJ]	6.72E+01	0.00E+00	0.00E+00	6.72E+01
Total use of non-renewable primary energy resources (PENRT) [MJ]	1.18E+03	1.45E+02	9.93E+01	1.42E+03
Use of secondary material (SM) [kg]	3.10E+01	0.00E+00	3.53E-03	3.10E+01
Use of renewable secondary fuels (RSF) [MJ]	0.00E+00	0.00E+00	0.00E+00	0.00E+00
Use of non-renewable secondary fuels (NRSF) [MJ]	0.00E+00	0.00E+00	0.00E+00	0.00E+00
Recovered energy (RE) [MJ]	0.00E+00	0.00E+00	0.00E+00	0.00E+00
Use of net fresh water (FW) [m ³]	1.90E+00	3.02E-02	1.02E-02	1.94E+00
Results of the LCA - output flows and waste categories: 1 metric tonne of precast concrete product				
	A1	A2	A3	Total
Hazardous waste disposed (HWD) [kg]	4.26E+00	1.75E-01	4.35E-02	4.48E+00
Non-hazardous waste disposed (NHWD) [kg]	1.04E+02	1.59E+01	1.38E+00	1.21E+02
High-level radioactive waste (HLRWD) [kg]	2.25E-04	1.87E-04	3.53E-04	7.64E-04
Intermediate and low-level radioactive waste	2.17E-04	1.81E-04	3.34E-04	7.32E-04
Components for reuse (CRU)	7.09E-02	0.00E+00	0.00E+00	7.09E-02
Materials for recycling (MFR)	2.89E+00	0.00E+00	0.00E+00	2.89E+00
Materials for energy recovery (RE)	0.00E+00	0.00E+00	0.00E+00	0.00E+00
Exported electrical energy (EEE) [MJ]	0.00E+00	0.00E+00	0.00E+00	0.00E+00
Exported thermal energy (EET) [MJ]	0.00E+00	0.00E+00	0.00E+00	0.00E+00
Additional Inventory Parameters				
	A1	A2	A3	Total
Emissions from calcination (kg CO ₂ e)	1.48E+02	0.00E+00	0.00E+00	1.48E+02

x-data not available for this inventory item. Not all LCA datasets for upstream materials include these impact categories and thus, results may be incomplete. Use caution when interpreting data in these categories.

For the specific system boundaries identified for this EPD, the raw material supply (phase A1) is the primary driver for all environmental impact categories with this phase accounting for over 85% of the total results for GWP, AP, EP and POCP and over 60% for ODP.

This is generally the result of the cement content in the concrete mixture as cement production requires high levels of energy for the calcining process while at the same time emitting CO₂ as part of the reaction from converting limestone (CaCO₃) to lime (CaO). Transportation may have a larger percentage of the total impact when raw materials are transported from long distances such as trans-oceanic locations.



Data Quality and Variability

The requirements for data quality and background data correspond with the requirements of the NSF International PCR for Precast Concrete. The calculated data in this report is based on actual precast concrete compositions. Manufacturer specific data is based on average data from the past 12 months.

The period over which inputs to and outputs from the system are accounted for is 100 years from the year for which the data is deemed representative.

The technology coverage reflects the physical reality for the declared precast concrete product. Used datasets are complete according to the system boundary within the limits set by the criteria for the exclusion of inputs and outputs.

To calculate the life cycle of the declared precast concrete products, the software One Click LCA with Ecoinvent 3.6. were used. The last revision of the Ecoinvent data is less than 3 years old. The data quality is considered high. This EPD was created using the default data when available or data as representative to the default data as possible noted in appendix A of the NSF International PCR for concrete.

A data quality assessment is provided in the Legacy Precast LLC Project Report.



References

Product Category Rules (PCR) for Precast Concrete UNPC: 37550. Version 3.0 of the Product Category Rules (PCR) for ISO 14025:2006 Type III Environmental Product Declarations (EPDs) of precast concrete – Issued May 30, 2021

ISO 21930:2017 Sustainability in Building Construction – Environmental Declaration of Building Products. Core rules for environmental product declarations of construction products and services.

ISO 14025:2010 Environmental labels and declarations – Type III environmental declarations – Principles and Procedures.

ISO 14040: 2006 Environmental Management – Life cycle assessment – Principles and frameworks.

ISO 14044:2006 Environmental management. Life cycle assessment. Requirements and guidelines.

ISO 21930:2017 Sustainability in Building Construction – Environmental Declaration of Building Products. Core rules for environmental product declarations of construction products and services.

GaBi ts 8.5: Software and GaBi database, LBP, University of Stuttgart and thinkstep AG, 2018.

Ecoinvent database v3.6 (2019) and One Click LCA database.

REACH Directive (EG) No. 1907/2006 of the European Parliament and of the Council dated 18 December 2006 on the registration, evaluation, approval and restriction of chemical substances (REACH), for establishing a European Agency for chemical substances, for amending Directive 1999/45/EC and for annulment of Directive (EEC) No. 793/93 of the Council, Directive (EC) No. 1488/94 of the Commission, Guideline 76/769/EEC of the Council and Guidelines 91/155/EEC, 93/67/EEC, 93/105/EC and 2000/21/EC of the Commission.