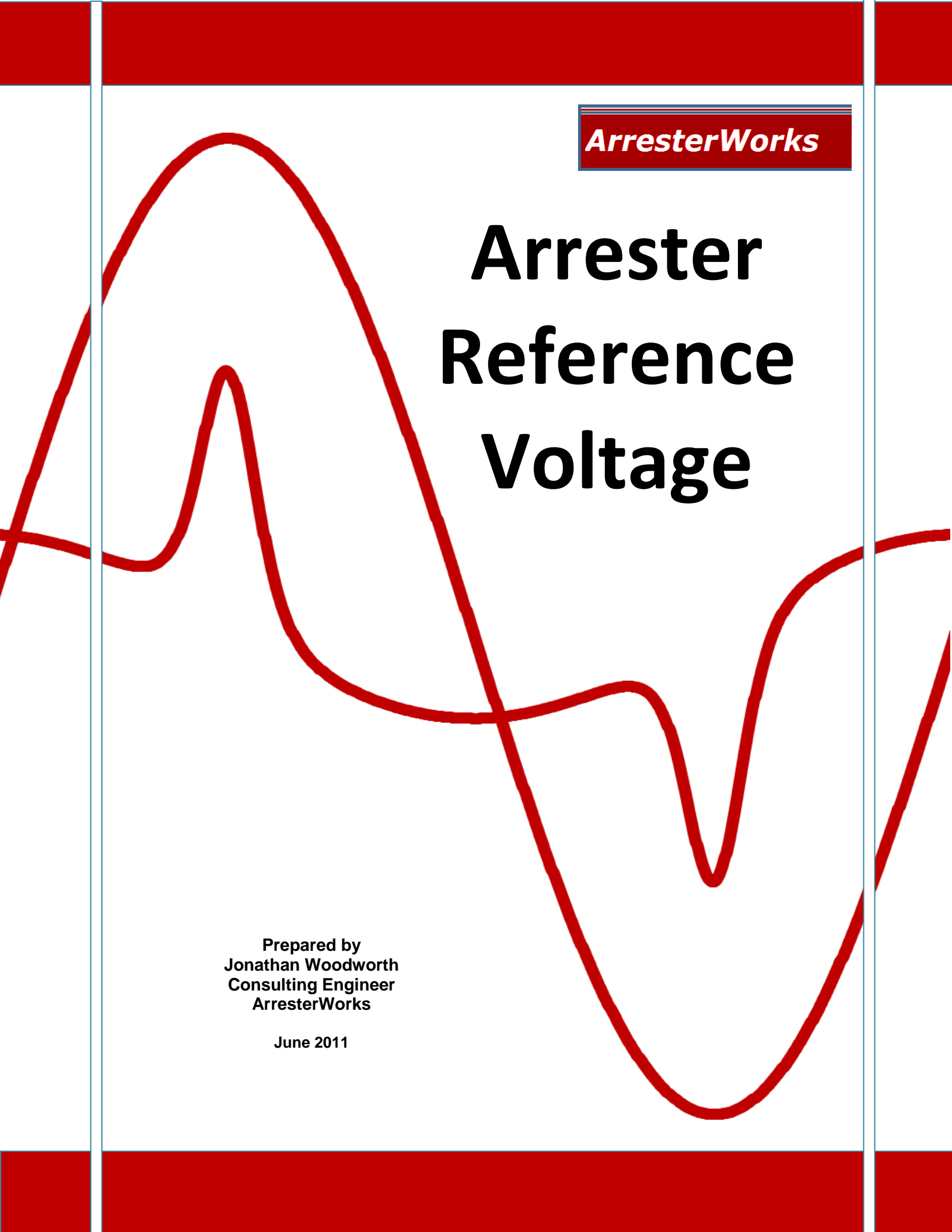

The logo for ArresterWorks, featuring the company name in a white, italicized sans-serif font inside a red rectangular box with a thin blue border.

ArresterWorks

A large, thick red waveform is overlaid on the white background, spanning across the page. It has multiple peaks and troughs, resembling a complex electrical signal or a lightning surge waveform.

Arrester Reference Voltage

Prepared by
Jonathan Woodworth
Consulting Engineer
ArresterWorks

June 2011

Arrester Reference Voltage

Introduction

From an arrester designer's perspective, the reference voltage of an arrester is perhaps the most important arrester characteristic to understand. Although it is not necessary for the casual user to have a complete understanding of an arrester's reference voltage, it is an important characteristic to understand for those who specify arresters. Also anyone interested in doing forensic analysis of arrester should have a good idea what this critical characteristic can reveal. In the future the reference voltage will play a bigger role in arrester energy testing. The upcoming editions of both IEC 60099-4 and IEEE C62.11 specify a pass/fail criteria based the change in the reference voltage characteristic from before and after the impulse withstand verification test.

Definitions

The IEC and IEEE definitions are the same.

Reference Voltage (V_{ref}) (U_{ref}):

The lowest peak value independent of polarity of power-frequency voltage, divided by the square root of 2, required to produce a resistive component of current equal to the reference current of the arrester or arrester element. The reference voltage of a multi-unit arrester is the sum of the reference voltages of the series units. The voltage level shall be specified by the manufacturer.

Reference Current (I_{ref}):

The peak value of the resistive component of a power-frequency current high enough to make the effects of stray capacitance of the arrester negligible. This current level shall be specified by the manufacturer.

NOTE—Depending on the arrester design, the reference current will typically be in the range of 0.05 mA to 1.0 mA per square centimeter of disk area.

AC Resistive Current:

The current flowing through a varistor that is in phase with the voltage. The dominate current above the knee on the VI curve.

AC Capacitive Current:

The current flowing through the varistor with a peak amplitude 90 deg from the peak voltage. This is the dominating current below the knee of the VI curve.

Background

It is not clear where the term reference voltage came from, but it appears as early as 1991 in the first IEC MOV Arrester Standard. In the 1976 Transient Voltage Suppression Manual by GE, a term V_x and I_x are discussed and have essentially the same definition as V_{ref} and I_{ref} . Another term that is similar to V_{ref} is V_{1ma} . V_{1ma} is the voltage developed across the terminals of a varistor when $1\text{ma}/\text{cm}^2$ DC is forced through an arrester.

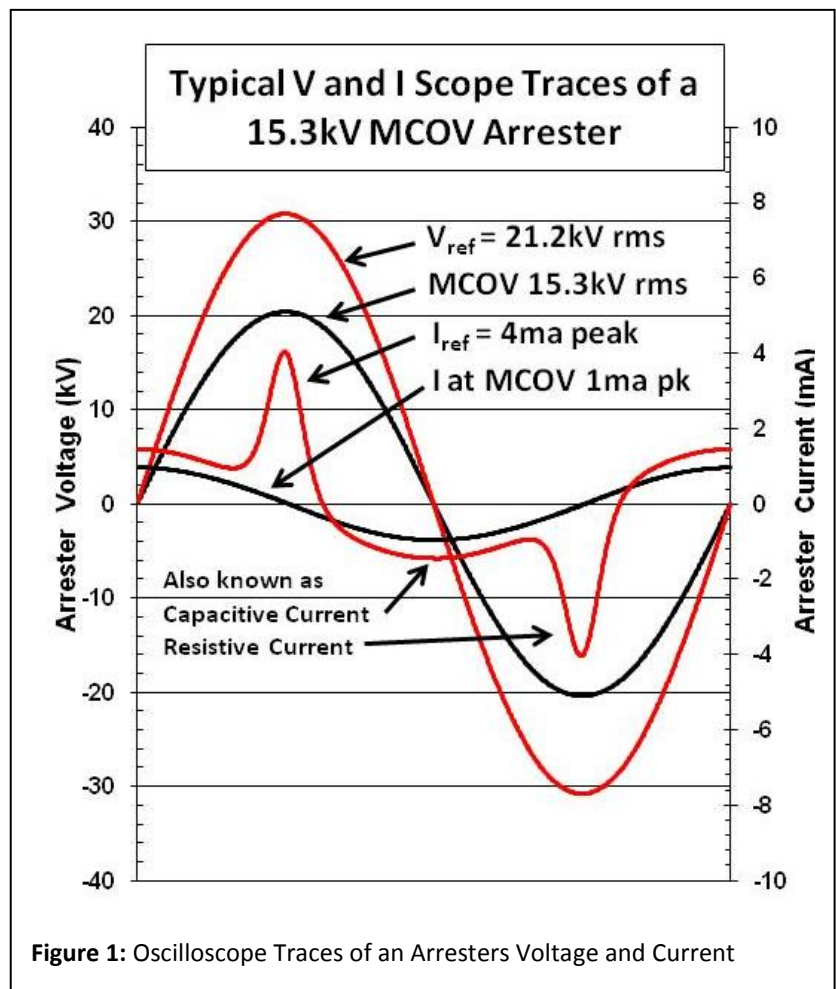

In all cases, the purpose of this voltage measurement is the same, too quantifying the point on the varistor's VI curve where significant conduction begins in earnest with no effect of capacitance or leakage currents. The term reference voltage is very appropriate, because this voltage measurement can be used to determine all other voltage-current characteristics of an arrester.

The Arrester VI Curve

A varistor is a variable resistor with its resistance controlled by the voltage stress impressed across the device. The varistor and arrester Voltage-Current Characteristic Curve (VI Curve) is the fundamental and simple way of showing how the resistance changes as a function of the voltage. This characteristic curve is used in many ways, and is heavily relied upon to understand and predict the performance of an arrester. Figure 2 is a typical VI curve for a 15kV MCOV arrester. Once a VI curve is determined for a varistor disk, the data can be used to predict the full arresters characteristics.

VI Curves often show only one polarity of the conduction curve of a varistor as does the one in Figure 2. Varistors are bidirectional devices, and the characteristic curve in the negative direction is identical for new non-impulsed varistors.

It is also important to understand that the curve represents the absolute voltage and current characteristic, essentially frequency independent. If a DC voltage is applied to the varistor with this characteristic curve, the resulting current will be the same as if it were an impulse with a peak voltage equal to the DC voltage. The test signals used to create this curve are generally 50 or 60 Hz below an amp and impulse above an amp.

Some important points on the VI curve are called out in Figure 2. These points are described in more detail here:

1. **Operating Range:** This is the region of a varistor's VI characteristic where the varistor spends its entire life. The conduction in this region is very close to zero with only minimal leakage current flowing through the device. This region is temperature sensitive and as the temperature of the device increases, the conduction increases at the same voltage. In other words the resistance decreases in this region as the temperature of the device increases.
2. **Peak MCOV:** This point shows the maximum voltage stress reached during normal operations. MCOV is typically specified in RMS terms, which is a meaningless value on a VI curve since the

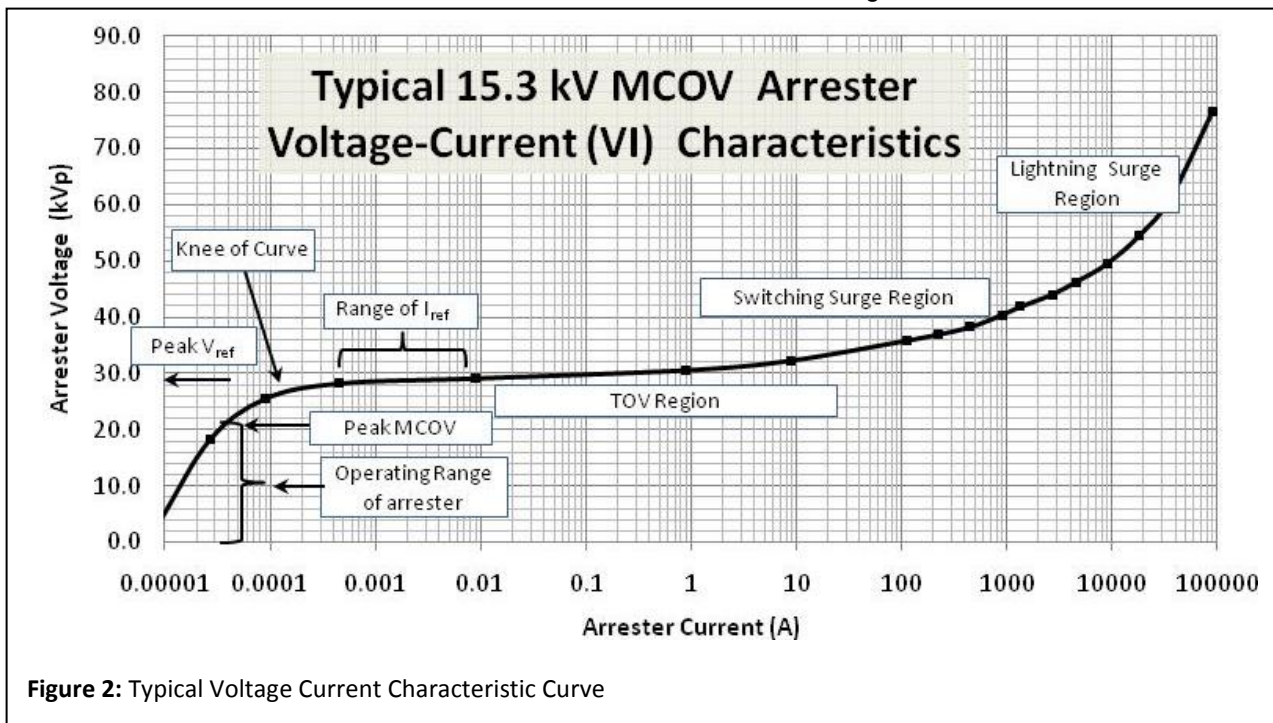

Figure 2: Typical Voltage Current Characteristic Curve

varistor reacts to absolute voltage only. The peak MCOV level of an arrester is in the range of 70-85% of the V_{ref} of the arrester.

3. **Knee of the Curve:** This is a loosely used term that roughly describes the voltage stress region where the conduction paths through the varistor rapidly change from the operating or leakage region to the conduction region. On a log-linear scale as shown in Figure 2, it appears as a knee on the curve.
4. **V_{ref} - I_{ref} :** The V_{ref} region is found just above the knee of the curve. This is also the region of conduction where there is more current flow through the zinc oxide grains and junctions than through the leakage current conduction paths. In this region the resistive current dominates the current flow and the capacitive current flow is not dominating. See Figure 1 for a better view of resistive and capacitive current. This region is not set at a specific current level, to allow manufactures to pick the current level that best fits their design. The voltage in this region changes very little with large changes in current. This is where the non-linear behavior of the varistor becomes very apparent. In this region of the VI curve, the varistor is dissipating considerable power and is not considered a long term operation.
5. **TOV:** The Temporary Overvoltage section starts just above the knee of the curve and in fact includes the V_{ref} point. It can extend up to 10s of amps. There is no generally defined upper end of this region. During a TOV event such as a voltage rise on an unfaulted phase of a power system, the voltage level is often high enough in amplitude to cause these levels of current to flow. During conduction in this region, the varistor is rapidly heating since there is considerable energy dissipation taking place that is beyond the normal state.
6. **Switching Surge and Lightning Surge:** For both of these regions, the varistor is in major conduction. This type conduction occurs in impulse form only and the duration of the surges are from the low milliseconds at the switching surge end, to a few microseconds at the higher current regions. The VI characteristic is very temperature insensitive in this region. There does appear to be a slight frequency effect in this region of the curve.

Measuring Methods

Precise Measurement

A V_{ref} measurement is usually carried out in a few seconds. If the measurement takes too long, the temperature of the device can reach damaging levels for the varistor material. If a V_{ref} measurement took 10 minutes, the test equipment would surely not be able to sustain the voltage level and the varistor would certainly be in a failure mode.

The most common means of measuring V_{ref} , is to apply an AC voltage across the varistor while monitoring the current. The AC rms voltage across the sample that results in a peak current conduction through the sample equal to desired I_{ref} , is then taken as V_{ref} . This procedure can be done by hand while monitoring a scope or fast responding digital meter. It can be done automatically by properly

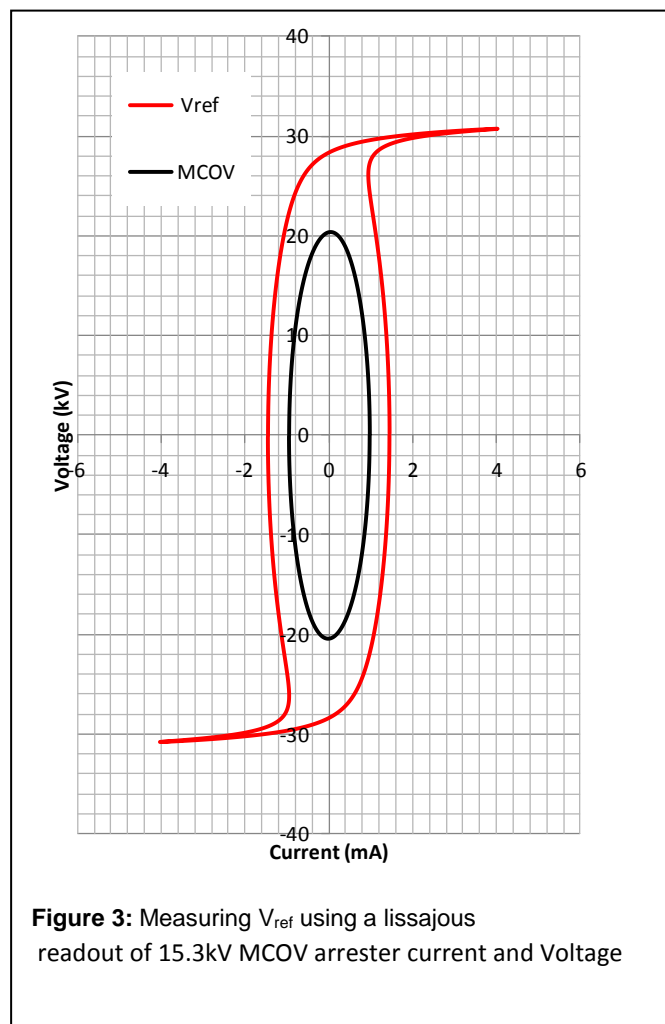

Figure 3: Measuring V_{ref} using a lissajous readout of 15.3kV MCOV arrester current and Voltage

calibrated and set up equipment. In either case, the voltage and current are simultaneously measured to achieve the measurement.

For optimum test results, the power source should be strong enough to produce 5-10ma without significant distortion of the voltage waveshape.

When measuring V_{ref} , the waveshapes should be similar to those found in Figure 1 and 3. The readout as shown in Figure 3 has the advantage of clearly showing the peak reference current when measuring V_{ref} .

It is important that the resistive current is at least visible and measureable and not dominated by the capacitive current as it is at MCOV.

Non-precise measurements

When a stiff or strong AC source is not available for a V_{ref} measurement, a weak source can also provide good results. An example of a weak source would be a typical AC High-Pot tester. These devices have currents available in the range of 1-10 mA maximum but with significant wave distortion at that level. These devices however do have excellent current trip sensors along with built in voltage and current meters. If the current trip sensor is set for about 1ma, it can be used to detect when the arrester voltage has reached V_{ref} by tripping out just as it reaches conduction.

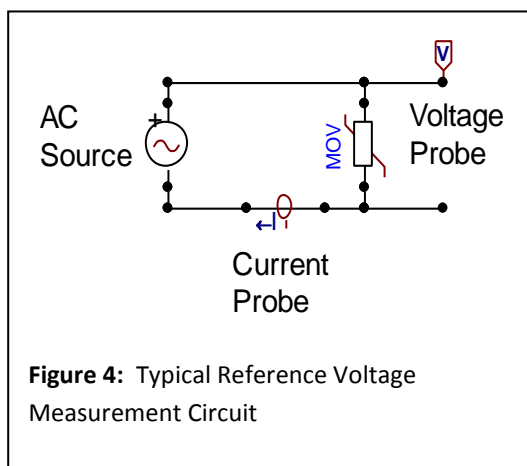

Production Tester Considerations

Per IEC 60099-4, routine tests for arrester must include the measurement of V_{ref} . The actual verbiage is as follows.

“The reference voltage of each arrester shall be measured by the manufacturer at the reference current selected by the manufacturer. The minimum reference voltage of the arrester at the reference current used for routine tests shall be specified and published in the manufacturer's data”

It goes on to also specify that:

“measurement of reference voltage (U_{ref}). The measured values shall be within a range specified by the manufacturer”

If the range as specified by the manufacturer is stated as “15.5kV and up”, then the routine test need only detect the minimum reference voltage. However if the range is stated as “15.5 to 17.9kV”, then a precise measurement must be made detecting both minimum and maximum levels of V_{ref} . Since the standard indicates that only a minimum V_{ref} need be published, the routine test for arresters generally is a min value test, leaving the maximum unspecified.

If the reference voltages of two different models are being compared, it is important to know what reference current was used for the V_{ref} test otherwise the comparison may be invalid.

Reference Voltage as an indicator of Surge Degradation

It is a well known fact that varistors can experience a change in conduction after a high current impulse. The level of damage is a strong function of the manufacturer of the device and the magnitude of the surge. It is not clear what actually happens at the junction level of the varistor material, but the conductivity change can be accurately measured using V_{ref} measurements. Figure 5 is an example of a scope readout for an impulse degraded arrester. It has a lower reference voltage at the same reference current and the current conduction is different between the positive and negative polarities. This is referred to as asymmetrical conduction.

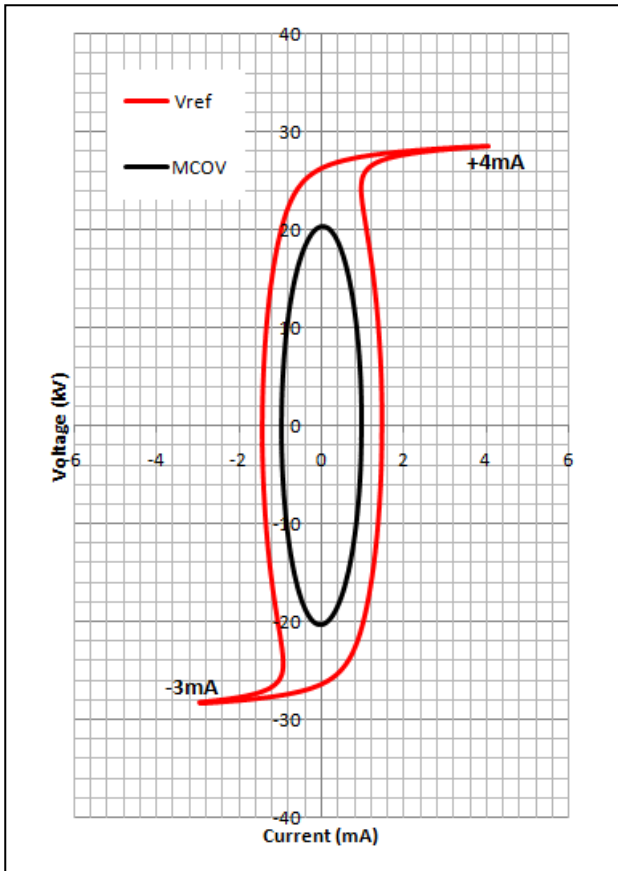

Figure 5: Vref measurement of an impulse degraded 15.3kV MCOV Arrester. Note: Lower and asymmetrical Vref lissajous indicates conduction difference between pos and neg polarities

Using V_{ref} in Arrester Forensic Analysis

If an arrester has experienced an end-of-life event, it is possible to determine if a high current surge was part of that event by measuring the V_{ref} of the disks that remain. It is however extremely important to make sure all of the arcing products are removed from the disks before the measurement is made. Even if the original V_{ref} level is not known, the asymmetry as shown in Figure 5 will be present if a high current surge was involved.

Reference Voltage and TOV

It is not obvious, but if a closer look is taken at the VI trace in Figure 2, it can be seen that V_{ref} level and TOV level are very close together. This relationship is fairly constant across all arrester designs. In other words, by design, V_{ref} and V_{TOV} will be close. However the ratio between V_{ref} and MCOV is completely at the discretion of the arrester designer. If it is desirable for an arrester to have a better TOV withstand capability, the arrester can be de-rated so that there is more distance from MCOV peak and V_{ref} . This is easily done by adding more disks to an arrester design. However as it can be seen in Figure 6, it also increases the discharge voltage at 10kA which is not usually desirable.

Using V_{ref} in New Energy Tests

Because of the fact that impulse degradation is a universal effect of excessive impulse current, it has been chosen to be an early indicator of maximum energy handling capability. In the next edition of both IEC 60099-4 and IEEE C62.11 new impulse withstand tests will be specified and as part of the pass/fail criteria, a change in V_{ref} will be required. At the moment a change of up to 5% in V_{ref} will be acceptable. This will be the first time that V_{ref} will be used to evaluate performance of an arrester.

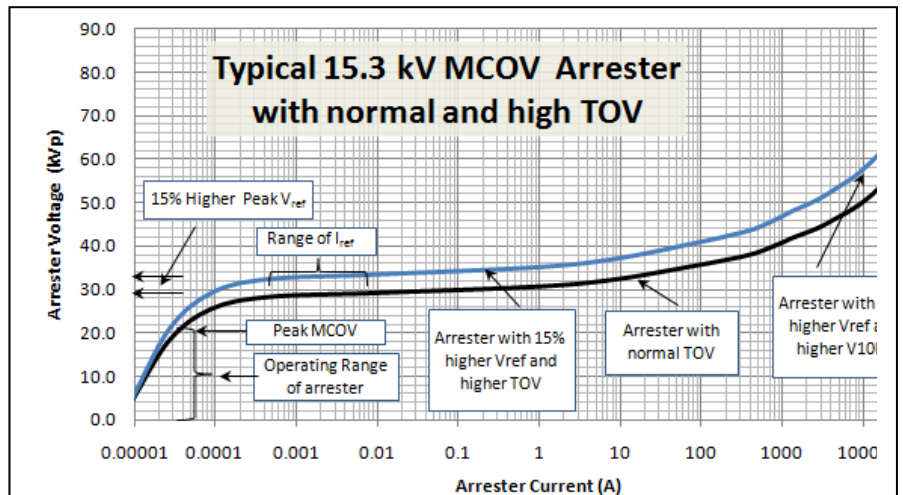

Figure 6: 15.3kV MCOV Arrester with two different Reference Voltages and TOV

Summary

The reference voltage of an arrester is a very important characteristic and related to many other arrester characteristics. Understanding it is essential to running effective tests and performing accurate comparative analysis.

About ArresterFacts

ArresterFacts are copyrighted documents by ArresterWorks. However if they are used for educational purposes, they can be copied and used

in any form. However if doing so, please give credit to ArresterWorks.

Thanks for using ArresterWorks as your source of Arrester and Surge Understanding.

If you ever have any questions about this or other arrester issues, contact Jonathan Woodworth at jonathan.woodworth@arresterworks.com

Visit www.arresterworks.com for all you surge protection needs.