

Searching for the Center of an Ellipse*

Michael A. Burr[†]

Alexandra Lauric

Katelyn Mann[‡]

Abstract

Biedl *et al.*[1] first posed the problem of finding the center of a circle, starting from a point on the boundary, using a limited number of operations. We solve an open problem, presented in their work: finding the center of an ellipse. We present new algorithms for finding the center of the ellipse and provide results of experiments showing how these algorithms perform under the introduction of errors.

1 Introduction

Biedl *et al.*[1] first posed the question of finding the center of a circle, starting with a point on the boundary, where the only allowed operations are an interior and exterior query, marking a point, and computing the line or midpoint between any two marked points. We consider one of the open problems posed in their paper: finding the center of an ellipse using the same operations. While the results presented in the original paper work quite well for circles, the algorithms fail for ellipses, more dramatically the greater the eccentricity. We present new algorithms and discuss some properties of existing algorithms for determining the center of an ellipse and include experiments that compare these methods. We structure our paper in a parallel manner to Biedl *et al.*[1] to more easily compare the similarities and differences between the task in a circle and an ellipse.

The motivation comes from quickly finding a skier buried in an avalanche [5]. Each skier carries a small radio, called a transceiver, which can either transmit or receive a signal, whose strength is monotonically related to the distance between transceivers, and which is initially set to transmit. When an avalanche occurs, everyone not buried turns his/her transceiver to receive signals from people buried in the snow. As Biedl *et al.*[1] claim that an ellipse more accurately models the transceiver's range, we focus on the task of finding the center of an ellipse given that we start on the boundary of the ellipse and leave the task of finding the broadcast region of the buried skier's transceiver and of finding the buried skier to the experts. Since time is critically important in finding a buried skier, we assume as in Biedl *et al.*[1], time is proportional to the distance traveled. Our algorithms consider the distance traveled and find the center of an ellipse such that the methods are accurate even when there are errors in the midpoint and angle calculations.

The problem: ([1]) Let E_1, \dots, E_k be a set of concentric ellipses with the same center, orientation, and eccentricity but different major and minor axes. E_1, \dots, E_k are ordered such that the length of the major axis of E_i is greater than the major axis of $E_{i+1} \forall i$. Given point p on the boundary of E_1 , find the center of the set of concentric ellipses where

the only allowed query determines whether a point is interior to ellipse E_i . The number of ellipses is known, but the eccentricity or the length of the axes is not known.

Since our application is for skiers, searching in the snow, we assume the following operations are allowable. The skier can mark his current position (and can make an unlimited number of marks), the skier can see his ski tracks, the skier can travel between any two markers, the skier can find the midpoint between any two markers, the skier can make a 90° turn or a 180° turn at any point, and the skier can mark where two of his tracks intersect. The statement of the problem mimics Biedl *et al.*'s [1] formulation except that we are looking at ellipses and that we can mark the intersection of two tracks. Additionally, we first analyze the case where $k = 1$ and then consider the case where we have different volume levels. Even with these small changes, the problem becomes quite different from the problem studied by Biedl *et al.* and the previously introduced methods do not result in the center of the ellipse.

Applying the **traditional strategy** [4] from the avalanche handbook to an ellipse would yield the following:

1. Start from an arbitrary point p on the ellipse and move in a direction that leads inside of the ellipse. Stop when the signal fades. We have the first chord e_1 .
2. Find the midpoint of e_1 and move to that point. Make a 90° turn in either direction and move in that direction until the signal fades. Turn 180° and move in that direction until the signal fades. We have the second chord e_2 , the perpendicular bisector of e_1 .
3. Find the midpoint of e_2 , this point is returned as the center of the ellipse. The handbook suggests repeating step 2 three or four times to reduce error.

This method works well in a circle since the perpendicular bisector of a chord is always a diameter. This property is not true for ellipses (Fig. 1). Nonetheless, the traditional method converges to the center of the ellipse as a geometric sequence (Sec. 2.1).

Applying the **right-angle strategy** of Biedl *et al.*[1] yields the following steps:

1. Start from an arbitrary point p on the ellipse and move in a direction that leads inside of the ellipse. Stop when the signal fades, producing chord e_1 .
2. At the second endpoint, determine if we can take a 90° turn (there will be either zero or one turns that admit a 90° turn).
 - (a) If we cannot turn, then find the midpoint of e_1 , this point is returned as the center of the ellipse.¹
 - (b) If we can take a 90° turn, take that turn and move in that direction until the signal fades. We have the second chord e_2 , perpendicular to e_1 , where

¹We add this step for correctness when e_1 is already a diameter.

*Department of Computer Science, Tufts University
{mburr, alauri02, kmann03}@cs.tufts.edu

[†]Supported by NSF-CCF grant #0431027

[‡]Supported by Clare Boothe Luce Fellowship

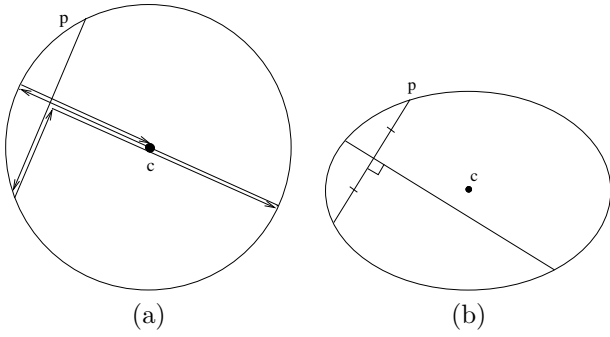

Figure 1: The traditional strategy performed on a circle (a) and an ellipse (b), the perpendicular bisector of a chord passes through the center of a circle, but not in an ellipse.

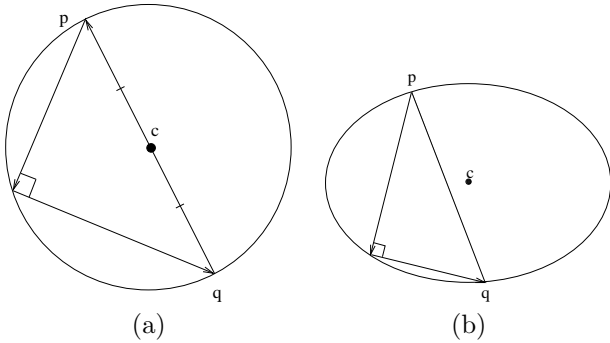

Figure 2: Right-angle strategy performed on (a) a circle and (b) an ellipse, the hypotenuse of the inscribed right triangle passes through the circle's center, but not for an ellipse.

the signal fades is point q .

- Find the midpoint of the chord between q and p and return it as the center of the ellipse.

This method works for circles since every inscribed right triangle has a diameter as hypotenuse. This property is not true for ellipses (Fig. 2). We evaluate the average distance from the center computed by this method to the actual center in Sec. 4.

We present several new methods for finding the center of an ellipse with an experimental analysis that includes the introduction of errors in the computation of certain angles and the determination of midpoints.

2 The parallel chords strategy

2.1 Properties of Parallel Chords

We describe a transformation from an ellipse to a circle and use this transformation to prove many properties. To make the calculations easier, we will assume w.l.o.g. that we are starting with an ellipse, centered at the origin, axis aligned with major axis along the x -axis, and minor axis of length 1. This results in the following form for the ellipse:

$\frac{x^2}{a^2} + y^2 = 1, a \geq 1$. Then the parallel projection, $\begin{pmatrix} \frac{1}{a} & 0 \\ 0 & 1 \end{pmatrix}$

is a bijection between the ellipse and the unit circle.

Sketch of proof ([2]) To show that the map maps the ellipse into the unit circle, we note that a point on the ellipse can be written as $(a\sqrt{1-y^2}, y)$. Then under the transformation, the point on the ellipse maps to the point $(\sqrt{1-y^2}, y)$, which is easily seen to lie on the unit circle.

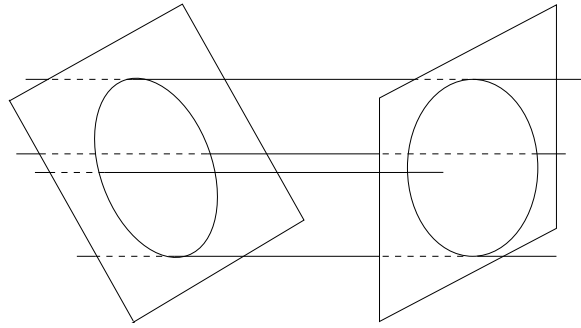

Figure 3: Parallel projection: maps an ellipse to a circle [2].

Similarly, the inverse map, $\begin{pmatrix} a & 0 \\ 0 & 1 \end{pmatrix}$, maps the unit circle to our ellipse. Since the two matrices are inverses as matrices, the bijectivity of these maps follows.

This map can be thought of as viewing an ellipse on a paper from an angle (Fig. 3). Finally, we state without proof the following facts that follow from the linearity and bijectivity of the maps. These maps map:

- Straight lines to straight lines
- Parallel lines to parallel lines
- Equal pairs of distances (measured along parallel lines) to equal pairs of distances, the maps scale distances along parallel lines equally.
- Midpoints of segments are mapped to midpoints, this follows from 3.

Using this transformation we use the circle to prove several properties about ellipses.

Proposition 1 *In an ellipse, the set of midpoints of parallel chords lie on a line through the origin.*

Proof. Consider the image of the parallel chords under the parallel projection described above. Then by property 1. the images are parallel chords in the circle. Additionally, from circle geometry, the diameter perpendicular to this set of parallel lines bisects each of these chords. Thus the midpoints of the chords in the circle lie on a line, but then by property 1. and 4., under the inverse transformation, this line maps to a line passing through the midpoints of each of the original chords. The line passing through the midpoints of each of the original chords also passes through the center of the ellipse since it is the image of a diameter, every diameter contains the point $(0, 0)$, which is fixed under the projection above, so the line through the midpoints of the original chords must contain $(0, 0)$, the center of the ellipse. \square

With the above proposition, we can show that for ellipses, the traditional method converges to the center of the ellipse as step 2 is repeated. The statement of this proof is similar to a proof by Melhorn *et al.*[3], but is a tighter result and has a simpler proof.

Theorem 2 *Under the sequence of chords described in the traditional strategy, e_1, e_2, \dots , the sequence of midpoints of the odd numbered segments, p_1, p_3, \dots converges geometrically to the center of the ellipse.*

Proof. Under the transformation described above, the chords e_1, e_2, \dots will map to a pair of sets of parallel chords, e'_1, e'_2, \dots but do not necessarily intersect at right angles (as with the ellipse). Assume w.l.o.g. that the odd numbered

chords map to vertical chords and the even numbered chords have slope m . Finally, assume that chord e'_{2n+1} lies on the line $x = t$, where $t \in [0, 1]$ and $n \in \mathbb{N}$. Then the midpoint of chord e'_{2n+1} is the point $(t, 0)$ and the chord e'_{2n+2} lies on the line, $y = m(x - t)$, and this line intersects the unit circle at the following points:

$$(x)^2 + (m(x - t))^2 = 1$$

$$\Rightarrow x = \frac{2m^2t \pm \sqrt{4m^4t^2 - 4(m^2 + 1)(m^2t^2 - 1)}}{2(m^2 + 1)}$$

Then the average of the two solutions is $\frac{m^2}{m^2+1}t$, and thus the chord e'_{2n+3} lies on the line, $x = \frac{m^2}{m^2+1}t$. Since n was arbitrary, in the unit circle the midpoints converge geometrically. Since each of the distance measurements lie on the line, under transformation, the ratios of their distances are invariant by property 3, and thus converge geometrically. \square

2.2 Parallel Chord Algorithms

We present two strategies for locating an ellipse's center, that follow from proposition 1. The strategies consider the case when there is only one ellipse, $k=1$.

Strategy 1:

1. Start from an arbitrary point p on the ellipse and move in a direction that leads inside of the ellipse. Stop when the signal fades. We have the first chord e_1 (Fig. 4).
2. Find the midpoint of e_1 and move to that point. Make a 90° turn in any direction and move in that direction until the signal fades. Turn 180° and move in the opposite direction until the signal fades. We have the second chord e_2 , which is the perpendicular bisector of e_1 .
3. Find the midpoint of e_2 and move to that point. Repeat *step2* and find chord e_3 . e_3 is parallel to e_1 . Their midpoints determine a diameter of the ellipse.
4. Move from the midpoint of e_3 towards the midpoint of e_1 until the signal fades. Move in the opposite direction and find the second endpoint. This is the diameter of the ellipse; its midpoint is the center of the ellipse.

Strategy 1 involves 2 90° turns and 4 midpoint calculations.

Strategy 2:

1. Find e_1 following the instructions from strategy 1.
2. Find and mark the midpoint of e_1 . Return to one of its endpoints, make a 90° turn that leads inside the ellipse if it exists (if not use the special case of strategy 2). Move in that direction until the signal fades. We have the second cord e_2 (Fig. 4).
3. Again, make a 90° turn and find a direction that leads inside the ellipse. Move in that direction until the signal fades. We have the third cord e_3 . e_1 and e_3 are parallel.
4. Find the midpoint of e_3 and move towards the midpoint of e_1 until the signal fades. Move in the reverse direction to find the second endpoint of the diameter. The midpoint of the diameter is the center of the ellipse.

Strategy 2 involves two 90° turns and three midpoint calculations. This method works well if there are at least two searchers starting from a point s (Fig. 4). One searcher would find e_1 and e_2 , while the other would find e_3 . Once the midpoints of e_1 and e_3 are marked, the searchers find the endpoints of the corresponding diameter and move toward its midpoint, the center of the ellipse.

A special case of strategy 2 addresses the particular case when the first chord e_1 is perpendicular to the tangent to

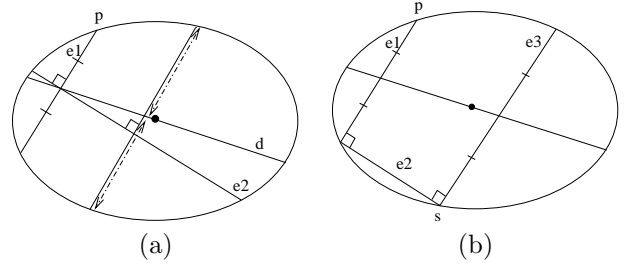

Figure 4: The chords created in strategy (a) 1 and (b) 2.

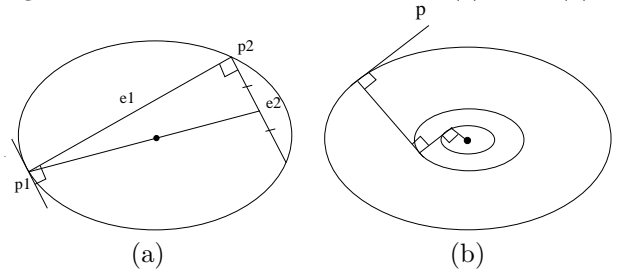

Figure 5: (a) Chords created in the special case of strategy 2. (b) A volume dependent method without markers.

the ellipse at the endpoint(s) (Fig. 5). This is the case when a searcher can not make a 90° turn in any direction while staying inside the ellipse. If the chord is perpendicular to both tangents then e_1 is a diameter of the ellipse and the search is done. If the chord is perpendicular to the tangent at one endpoint, p_1 , then follow the step 2 from strategy 2 and find a chord e_2 that starts at p_2 and is parallel to the tangent at p_1 . The midpoint of e_2 together with p_1 determines the diameter of the ellipse. The tangent can be considered the last parallel chord from all the chords parallel to e_2 .

3 Using volume

Transceivers usually have different volume settings and searchers can use them to reduce the search space. If the transceivers have continuous volume knobs the searchers can use them to find tangents to the inner ellipses. Namely, start from an arbitrary point and move along a chord as before, but continuously lower the volume until a local minimum is reached. The chord is the tangent to a smaller ellipse, concentric with the initial one. From this point a searcher continues in the same fashion and find tangents to increasingly smaller ellipses until reaching the center (Fig. 5).

If the transceivers have a fixed number of volume settings (usually 5-10), we can still use them to improve our strategies. Assume the searchers have found the endpoints of a diameter using one of the above methods. Then they turn their transceivers down to the lowest setting and start moving towards each other. When they first hear the signal, it means they approach the center of the ellipse. At this point, they could synchronize to meet at the center.

4 Experiments

As analytic solutions are difficult for ellipses, we provide experimental results. We compare the two strategies that we propose with the right angle strategy offered in [1]. Throughout this section we analyze ellipses with variable major axis length and fixed minor axis length of 1. All of our results extend to other fixed minor axis values through scaling and we report the values found through our simplification.

a	strat1	strat2	right
1	14.36	10.50	3.57
3	15.41	11.57	3.46
5	16.34	13.19	3.35
7	16.99	14.32	3.17
10	17.52	15.34	2.87

(a)

a	right
1	1.5e-8
3	1.14
5	2.15
7	3.15
10	4.64

(b)

Table 1: The a value, is the length of the major axis with minor axis of length 1. (a)The competitive ratio for each of three strategies, strategy 1, strategy 2, and the right angle strategy. (b)The average distance from the center for the right angle strategy.

The right angle strategy does not extend well to the ellipse. After running simulations on ellipses with varying major axes, we found that the distance that the skier is from the center of the ellipse is a linear function of the length of the major axis when the minor axis is fixed. Fixing the minor axis at 1, a linear regression fit resulted in the slope of the distance from the center and the length of the major axis had a value of .515 with an R^2 value of .999.

Strategies 1 and 2 always reach the center of the ellipse. Strategy 2 yields a slightly better competitive ratio, the ratio of the distance traveled to the actual distance between the first point on the ellipse and its center (1).

The avalanche handbook [4] suggests that for the traditional method, skiers perform four iterations before probing for the lost skier. Using our simplification, for a ellipse with major axis of length 2, it takes 16 iterations to be within 10^{-5} of the center; for a length of 5 it also takes 16 iterations to achieve the same bound; and for a length of 10, it take 64 iterations to reach the same level.

We introduce error similarly to Biedl *et al.* [1]. Turning 90° and finding a midpoint are the two actions that are prone to error. Strategy one is especially prone to error because it requires two 90° turns and four midpoint calculations. Strategy two improves on this slightly as it necessitates making two 90° turns and calculating only three midpoints. When turning 90° we assume that the skier could be off by up to $\pm 10^\circ$, and for the midpoint calculation, we assume that we could be off by a factor of 0.0125, where the error was chosen in both cases according to a normal distribution² around 0 with standard deviation of 0.05.

We simulated error in strategies one and two for various lengths of the major axis. As the eccentricity of the ellipse increased, so did the error for both strategies. We found that the error was greatest when the two parallel chords the searcher walks are very close together, in fact, if the skier is walking chords that are very close together, it might be better to start the strategy over facing in a different direction.

The error for strategy one grows more quickly than that of two, see table 2. The relationship between the length of the major access and the error in strategy one appears to be a quadratic polynomial, while strategy two appears to be a linear relationship, both with an R^2 value of .999.

²If the absolute value of the point chosen is greater than 1, we change the value to ± 1 .

a	strat1	strat2
1	.12	.10
3	.33	.34
5	.75	.59
7	1.36	.84
10	2.50	1.23

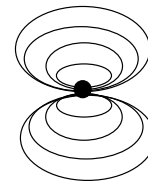

Table 2: The average distance from the center returned by the algorithms as eccentricity increases. The value of a is the length of the major axis, and the minor axis has fixed length one.

Figure 6: How the actual induction lines extend from the transceiver. We consider a large ellipse containing both smaller ellipses

5 Future Work and Open Problems

For the purpose of this paper we have assumed the induction lines from the transceivers are ellipses. In reality, the path of the induction lines is similar with the one in Fig. 6. The ellipses have “dead” areas where no signal is received. At this moment we have no good strategies to address this problem.

There is the question of the practicality of the methods we have presented. While our simulations theoretically showed that operations easily performed by skiers can find the center, only real-life experiments can determine if they have practical value.

Modern transceivers are more sensitive to the orientation between the search transceiver and the buried one, making it easy to determine the tangent to the induction line. When such transceivers are used, the searchers have the option of performing an “induction line tangent search” [5]. However it seems that while this method is great at covering a lot of space fast, it becomes a source of confusion when the searcher gets close to the center, with sudden direction changes. It would be interesting to see if we can combine the induction search with the special case of strategy 2.

Acknowledgements: We thank Biedl *et al.* for their comments and code, the Tufts computational geometry research group for their input, and John Hugg for his code.

References

- [1] T. Biedl, M. Hasan, J. D. Horton, A. López-Ortiz, and T. Vinař. Searching for the center of a circle. In *Proceedings of the 14th Canadian Conference on Computational Geometry (CCCG’02)*, pages 137–141, 2002.
- [2] D. A. Brannan, M. F. Esplen, and J. J. Gray. *Geometry*. Cambridge University Press, 1999.
- [3] K. Mehlhorn, T. C. Shermer, and C. K. Yap. A complete roundness classification procedure. In *SCG ’97: Proceedings of the thirteenth annual symposium on Computational geometry*, pages 129–138. ACM Press, 1997.
- [4] R. I. Perla and M. M. Jr. *Avalanche Handbook*. US Department of Agriculture, July 1976.
- [5] M. G. Smith. Avalanche transceiver recovery skills: Tips and traps, GearWorld www.gearworld.com, 1998.