

HANDBOOK
OF
PILOT OPERATIONAL EQUIPMENT
FOR
MANNED SPACE FLIGHT

Report No.
CD42-A/SL-997

Prepared By
POE Development Section
Crew Equipment and Design Branch
Flight Crew Integration Division



National Aeronautics and Space Administration
LYNDON B. JOHNSON SPACE CENTER
Houston, Texas

JUNE 1973

PROJECT DOCUMENT COVER SHEET

HANDBOOK OF PILOT OPERATIONAL EQUIPMENT FOR MANNED SPACE FLIGHT	
REPORT NUMBER CD42-A/SL-997	DATE June 16, 1972

PREPARED BY:	POE Development Section
APPROVED:	(BRANCH AND/OR SUPPORT OFFICE) <i>W. Schmidt/Kuehnel</i>
APPROVED:	(DIVISION) <i>Dean F. Grimmer 6-16-72</i>
APPROVED:	

REVISIONS					CHG. LETTER
DATE	PREPARED BY	APPROVALS			
		BRANCH	DIVISION	PROGRAM OFFICE	
9/5/72	H. D. Yeates	<i>HA Kuehnel</i>	<i>9-11-72</i>		A
3/15/73	H. D. Yeates	<i>HA Kuehnel</i>	<i>Dean F. Grimmer</i>	4-10-73	B

CD42-A/SL-997
 REPORT NUMBER

TABLE OF CONTENTS

	Foreword
	List of Illustrations
1.0	<u>Introduction</u>
2.0	<u>16 mm. Sequence Camera System</u>
2.1	Data Acquisition Camera (DAC) (SEB33100100)
2.2	DAC Film Magazine (140) (SEB33100125)
2.3	DAC Transport Mechanism (SEB33100278)
2.4	DAC Film Cassette (400) (SEB33100279)
2.5	5 mm. Lens (SEB33100056)
2.6	10 mm. Lens (SEB33100010)
2.7	18 mm. Lens (SEB33100018)
2.8	25 mm. Lens (SEB33100054)
2.9	75 mm. Lens (SEB33100019)
2.10	100 mm. Lens (SEB33100025)
2.11	180 mm. Lens (SEB33100017)
2.12	Right Angle Mirror (SEB33100051)
2.13	DAC Power Cable (CM) (SEB33100038)
2.14	DAC Power Cable (SWS) (SEC33100567)
2.15	DAC Spare Fuse (SEB33100266)
2.16	Remote Control Cable (SEB33100020)
2.17	DAC Power Pack (SEB33100304)
2.18	Universal Mount (SEC39106239)
2.19	DAC EVA Bracket (SEC33100006)
2.20	DAC Handle (SEB33100303)
2.21	DAC RCU Bracket (SEB33100396)

- 2.22 DAC Right Angle Adapter Bracket (SEB33100277)
- 2.23 DAC Wedge Bracket (SEB33100564)
- 3.0 35 mm. Still Camera System
- 3.1 35 mm. Nikon Camera (NK) (Motorized) (SEB33100772)
- 3.2 55 mm. Visible Lens (SEB33100773)
- 3.3 55 mm. UV Lens (SEB33100774)
- 3.4 Film Cassette Assembly (SEB33100775)
- 3.5 NK Battery Assembly (SEB33100777)
- 3.6 NK Timer (SEB33100776)
- 3.7 NK Timer Battery (SEC33100796)
- 3.8 Twin Filter Slide Assembly (SEC33100789)
- 3.9 Single Filter Assembly (SEC33100790)
- 3.10 35 mm. Filter Assembly (Haze) (SEB33100791)
- 3.11 35 mm. Nikon Camera (SEB33100008)
- 3.12 55 mm. Lens (SEB33100009)
- 3.13 Polarization Filter Assembly (SEB33100888)
- 3.14 35 mm. Filter Assembly (SEB33100889)
- 3.15 35 mm. Camera Bracket (SEB33100784)
- B 3.16 35 mm. Accessory Bracket Assy. (SEC33100945)
- B 3.17 E₂ Extension Tube (SEC33100895)
- B 3.18 35 mm. Lens (SEC33100938)
- B 3.19 Automatic Flash Assy. (SEC33100939)
- B 3.20 Automatic Flash Assy. Battery Pack (SEC33100940)
- 4.0 70 mm. Still Camera System
- 4.1 Hasselblad Data Camera (HDC) (SEB33100040)
- 4.2 Film Magazine (SEB33100082)
- 4.3 60 mm. Lens (SEB33100048)
- 4.4 80 mm. Lens (SEB33100261)
- 4.5 100 mm. Lens (SEB33100041)
- 4.6 Hasselblad Battery (SEB33100174)
- 4.7 Polarizing Filter (SEB33100113)

- 4.8 Handle and Trigger Assemblies (SEB33100293 and SEB33100294)
- 4.9 Hasselblad Electric Camera (HEC) (SEB33100102)
- 4.10 105 mm. UV Lens (SEB33100004)
- 4.11 250 mm. Lens (SEB33100032)
- 4.12 500 mm. Lens (SEB33100284)
- 4.13 Filter Assemblies (SEB33100050)
- 4.14 Intervalometer (SEB33100043)
- 4.15 Ring Sight (SEB33100031)
- 5.0 Earth Terrain Camera System
- 5.1 Earth Terrain Camera (ETC) (SEC33100786)
- 5.2 ETC Magazine (SEC33100787)
- 5.3 ETC Film Canister Assembly (SEC33100886)
- 5.4 SAL Window Assembly (SEC33100788)
- 6.0 Light Meter System
- 6.1 Spotmeter (SEB33100104)
- 6.2 Spotmeter Battery (SEB33100064)
- 7.0 Tape Recorder System
- 7.1 Voice Recorder (SEB33100262)
- 7.2 Tape Cassette (SEB33100263)
- 7.3 Recorder Battery (SEB33100264)
- 8.0 Miscellaneous Support Equipment
- 8.1 Monocular 10 x 40 (SEB12100078)
- 8.2 Binocular 10 x 40 (SEB12100037)
- 8.3 Sunglasses (SEB12100033) and Pouch (SEB12100034)
- 8.4 Chronograph (SEB12100039) and Watchband (SEB12100030)

8.5 Timer (SEB33100092)
8.6 Data Recording Pen (SEB12100051)
8.7 Pencil (SEB12100081)
8.8 Marker Pen (SEB12100082)
8.9 Slide Rule (SEB33100047)
8.10 Exerciser (SEB33100186)
8.11 Meter Cover (SEB33100063)
8.12 Tape (SEB12100050)
8.13 Lens Brush (SEB33100402)
8.14 EVA Retractable Tether (SEB33100291)
8.15 EVA Cuff Checklist (SEB33100302)
8.16 Wrist Mirror (SDB12100086)
B 8.17 Clip for Data File (SEB32100094)
8.18 Motion Sickness Bag (SEB12100085)
B 8.19 Leak Rate Indicator (SEC32100023)
B 8.20 Utility Bag (SEC12100087)
B 8.21 Optics Cleaning Kit (SEC33100890 and SEC33100891)

B 8.22 ATM Board Assembly (SEC32100188)
B 8.23 Knee Board Assembly (SEC32100189)
B 8.24 Double Clipboard Assembly (SEC32100187)
B 8.25 Double Clip Assembly (SEC32100179)
B 8.26 Support Equipment Container Assembly (SEC33100923)
B 8.27 Book Tether Assembly (SEC32100180)
B 8.28 Skylab Earth Orbital Map (SEC32100153)
B 8.29 United States Map Assembly (SEC32100161)
B 8.30 Large Data Card Kit (SEC32100162)

- B 8.31 Automatic Flash and Battery Assembly Bag (SEC33100943)
- B 8.32 Bag Assembly for 35 mm. Camera Lens (SEB33100944)
- B 8.33 Teleprinter Message Book (SKC32100155)
- B 8.34 Flight Data File Book Assembly Back (SKB32100142)
- B 8.35 Data Card Assembly Kit (SEB32100025)
- B 8.36 Data Card Kit Spring (SEB32100025)
- B 8.37 Tape Dispenser (SEB32100025)

Bibliography

✓

✓

LIST OF ILLUSTRATIONS

<u>Figure</u>	<u>Title</u>
2.1-1	Data Acquisition Camera Back, Top, and Front View
2.1-2	Data Acquisition Camera Rear View
2.2-1	DAC Film Magazine (140)
2.3-1	DAC Transport Mechanism (400)
2.4-1	DAC Film Cassette (400)
2.5-1	5 mm. Lens and Field-of-View Chart
2.6-1	10 mm. Lens and Field-of-View Chart
2.7-1	18 mm. Lens and Field-of-View Chart
2.8-1	25 mm. Lens and Field-of-View Chart
2.9-1	75 mm. Lens and Field-of-View Chart
2.9-2	75 mm. Lens with Extender
2.10-1	100 mm. Lens and Field-of-View Chart
2.10-2	100 mm. Lens with Extender
2.11-1	180 mm. Lens and Field-of-View Chart
2.12-1	Right Angle Mirror
2.13-1	DAC Power Cable (CM)
2.14-1	DAC Power Cable (SWS)
2.15-1	DAC Spare Fuse Assembly
2.16-1	Remote Control Cable (-305)
2.17-1	DAC Power Pack (-305)
2.18-1	Universal Mount
2.19-1	DAC EVA Bracket
2.19-2	Skylab DAC EVA Assembly
2.20-1	DAC Handle
2.21-1	DAC RCU Bracket
2.22-1	DAC Right Angle Adapter Bracket
2.23-1	DAC Wedge Bracket
3.1-1	35 mm. Nikon Visible Camera (-301) and Lens
3.1-2	35 mm. Nikon UV Camera (-302) and Lens
3.1-3	Nikon Back View
3.1-4	Nikon with Back Open

	3.2-1	55 mm. Visible Lens
	3.3-1	55 mm. UV Lens
	3.3-2	UV Lens Spectral Transmission
	3.4-1	Film Cassette Assembly
	3.5-1	Nikon Battery Assembly
	3.5-2	Battery Installation in Nikon
	3.6-1	Nikon Timer
	3.6-2	Connection of Timer to Nikon
	3.7-1	Nikon Timer Battery
	3.8-1	Twin Filter Slide Assembly
	3.8-2	Twin Filter Assembly Installed on Nikon
	3.9-1	Single Filter Assembly
	3.10-1	Haze Filter Assembly
	3.11-1	35 mm. Nikon Camera and Lens
	3.13-1	Polarizing Filter Assembly
	3.14-1	35 mm. Filter Assembly
	3.15-1	35 mm. Camera Bracket
B	3.17-1	E ₂ Extension Tube
B	3.18-1	35 mm. Lens
B	3.18-2	35 mm. Lens Field-of-View Chart
B	3.19-1	Automatic Flash Assy.
B	3.19-2	Automatic Flash Assy. Battery Pack
	4.1-1	Hasselblad Data Camera, Front View
	4.1-2	Hasselblad Data Camera, Rear View
	4.1-3	HDC Glass Reseau Plate
	4.1-4	Reseau Grid Layout
	4.1-5	Lunar Surface HDC/60 mm. Lens Assembly
	4.1-6	Lunar Surface HDC/500 mm. Lens Assembly
	4.2-1	Film Magazine (-301) for Skylab Use
	4.2-2	Film Magazine (-217) for Lunar Surface Use
	4.3-1	60 mm. Lens and Field-of-View Chart
	4.3-2	60 mm. Lens Installed on HDC
	4.3-3	60 mm. Lens Radial Distortion (Typical)
	4.4-1	80 mm. Lens and Field-of-View Chart
	4.4-2	80 mm. Lens Radial Distortion (Typical)
	4.5-1	100 mm. Lens
	4.5-2	100 mm. Lens Radial Distortion (Typical)

4.6-1 Hasselblad Battery and Installation
4.7-1 Polarizing Filter
4.7-2 Filter Installed on 60 mm. Lens
4.8-1 Handle and Trigger Assembled on HDC
4.9-1 Hasselblad Electric Camera, Front View
4.9-2 Hasselblad Electric Camera, Rear View
4.9-3 Hasselblad Electric Camera, Bottom View
4.10-1 105 mm. UV Lens
4.10-2 Spectral Transmission (Typical)
4.11-1 250 mm. Lens and Field-of-View Chart
4.12-1 500 mm. Lens and Field-of-View Chart
4.12-2 Lunar Surface 500 mm. Lens (-302)
4.13-1 Typical Filter Assembly
4.14-1 20-Second Intervalometer (-301)
4.14-2 8-Second Intervalometer (-302)
4.15-1 Ring Sight Installed on HEC
4.15-2 Ring Sight Viewing Characteristics
5.1-1 Earth Terrain Camera Assembly, Front View
5.1-2 Earth Terrain Camera Assembly, Rear View
5.1-3 ETC Control Box Face
5.2-1 ETC Magazine, Front View
5.2-2 ETC Magazine, Rear View
5.3-1 ETC Film Canister Assembly
5.4-1 SAL Window Assembly
5.4-2 ETC Installed in OWS
6.1-1 Spotmeter, Front View
6.1-2 Spotmeter, Rear View
6.1-3 Spotmeter Scales
6.2-1 Spotmeter Battery
7.1-1 Voice Recorder with Cassette and Battery
7.1-2 Voice Recorder, Side View
7.1-3 Voice Recorder Controls
7.2-1 Tape Cassette

	7.3-1	Recorder Battery
	8.1-1	Monocular, 10 x 40
	8.2-1	Binocular, 10 x 40
	8.3-1	Sunglasses and Pouch
	8.4-1	Chronograph and Watchband
	8.5-1	Timer
	8.6-1	Data Recording Pen
	8.7-1	Pencil
	8.8-1	Marker Pen
	8.9-1	Slide Rule
	8.10-1	Exerciser
	8.11-1	Meter Covers
	8.12-1	Tape Roll
	8.13-1	Lens Brush
	8.14-1	Small EVA Retractable Tether (-301, -304, -305)
	8.14-2	Large EVA Retractable Tether (-303)
	8.15-1	EVA Cuff Checklist
B	8.17-1	Clip for Data File
	8.18-1	Motion Sickness Bag, Stowed Configuration
	8.18-2	Motion Sickness Bag
B	8.19-1	Leak Rate Indicator
B	8.20-1	Utility Bag
B	8.21-1	Optics Cleaning Kit, Large
B	8.21-2	Optics Cleaning Kit, Small
B	8.22-1	ATM Board Assemblies
B	8.23-1	Knee Board Assembly
B	8.24-1	Clipboard Assembly
B	8.25-1	Double Clip Assembly
B	8.26-1	Container, Closed
B	8.27-1	Book Tether
B	8.28-1	Skylab Earth Orbital Map

B	8.29-1	United States Map
B	8.30-1	Large Data Card Kit
B	8.32-1	Bag for 35 mm. Camera Lens
B	8.33-1	Teleprinter Message Books
B	8.34-1	Back for Flight Data File Book
B	8.35-1	Data Card Assembly Kits
B	8.36-1	Spring Data Card Kit
B	8.37-1	Tape Dispenser

FOREWORD

This handbook presents the important configurations and functional characteristics of the pilot operational equipment provided by the Crew Equipment and Design Branch for the Apollo and Skylab Programs. The various operational camera systems and miscellaneous crew support items are included. The descriptive information is presented concisely and illustrated appropriately.

Introduction

This handbook presents the various configurations and the functional characteristics of the pilot operational equipment provided by the Crew Equipment and Design Branch for the Apollo and Skylab Programs. The operational camera systems - 16 mm. sequence, 35 mm. and 70 mm. still, and 5-inch earth terrain - comprise the major portion of the included hardware items. The remainder of the handbook covers the miscellaneous crew support equipment - tape recorder system, binoculars, watches, pens and pencils, tape, etc.

The significant configurations of each hardware item are listed with their distinguishing characteristics and typical utilization. Further detailed information concerning configuration peculiarities and additions should be obtained from the Crew Equipment and Design Branch.

The equipment characteristics are provided in a concise outline format for increased detail visibility. Photographic and graphical illustrations are coordinated with the hardware descriptions to furnish a full delineation of the characteristics and capabilities.

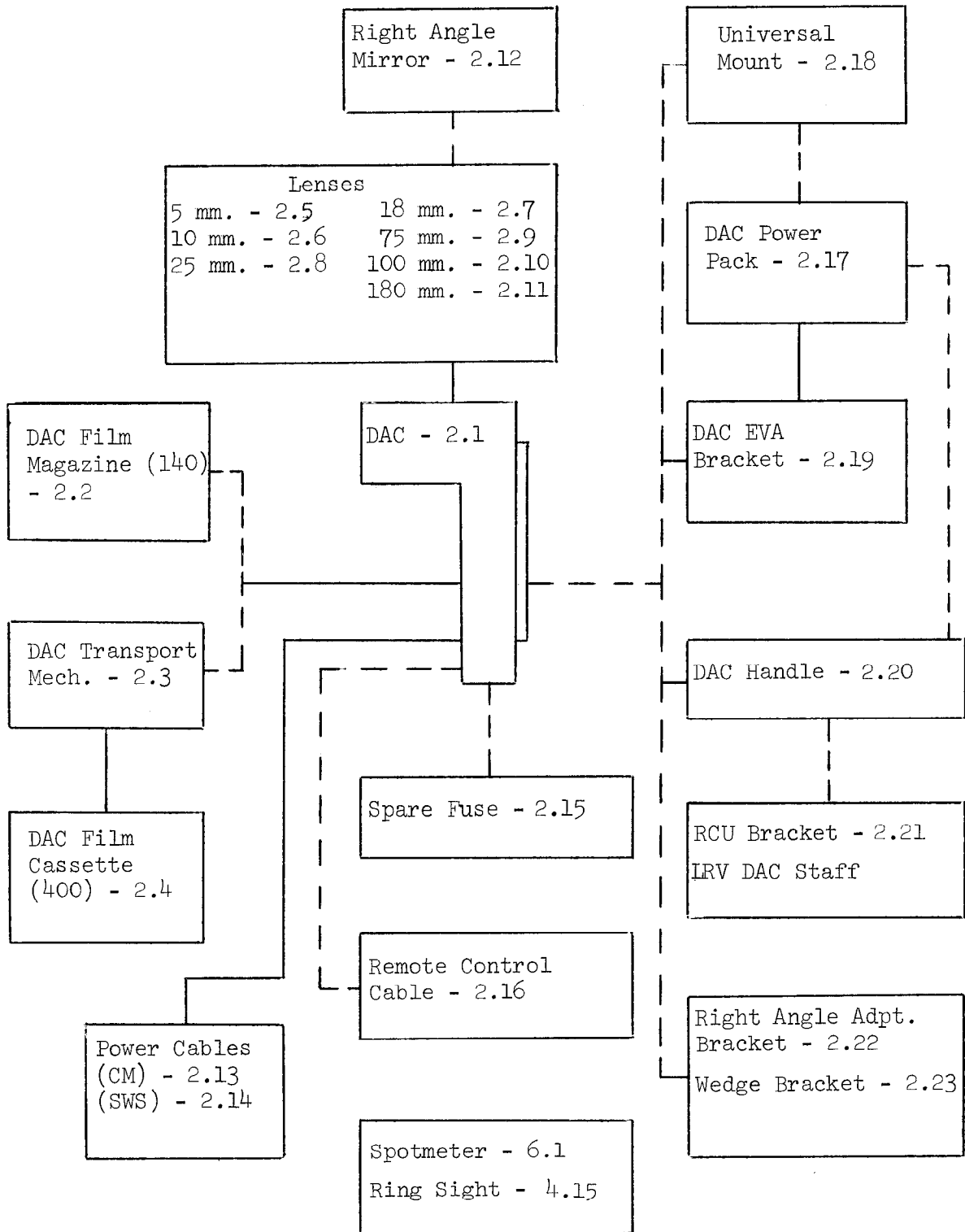

2.1 Data Acquisition Camera (DAC) (SEB33100100):

The 16 mm. Data Acquisition Camera (DAC) is used to obtain sequential photographic data during manned space flight missions. Unlike typical movie cameras, this unit has independent shutter speeds and framing rates. Furthermore, the automatic frame rates are lower than the common cine speeds to maximize film usage while maintaining the desired engineering data value. The DAC can be handheld or bracket mounted, can operate from spacecraft or portable battery power, and can accept various lenses and assorted accessories as described in the following sections of this handbook.

2.1.1 Significant Configurations:

<u>Configuration</u>	<u>Purpose</u>
-211	Skylab flight unit; 2 fps mode instead of 1 fps
-216	Skylab support unit; 2 fps mode instead of 1 fps
-217	Apollo CM and LM flight unit
-218	Apollo lunar surface flight unit; operate light hood incorporated

2.1.2 Characteristics:

- Manufactured by J. A. Maurer, Inc., Long Island City, New York 11101.
- Weight - 1.7 lbs (771 g.)
Envelope - 6 x 3.75 x 2.4 in. (15.2 x 9.5 x 6.1 cm)
Volume - 54 in³ (885 cm³)
- Power requirements: 28 + 4 VDC at 0.6 amps nominal from spacecraft or DAC Power Pack (see 2.17). DAC incorporates self-resetting overload protection circuit and replaceable power line fuse (1.5 or 2.0 amp) (see 2.15).
- Sequencing frame rate settable to 1 (or 2), 6, 12, or 24 frames per second (fps) and time exposure.

Automatic Modes [1 (or 2), 6, and 12 fps] are initiated by depressing and releasing camera front button and continue uninterrupted even if sequencing rate is changed among automatic modes. Camera operation is stopped by depressing and releasing front button or by switching to the time exposure or 24 fps mode settings. Green operate light will flash at frame rate.

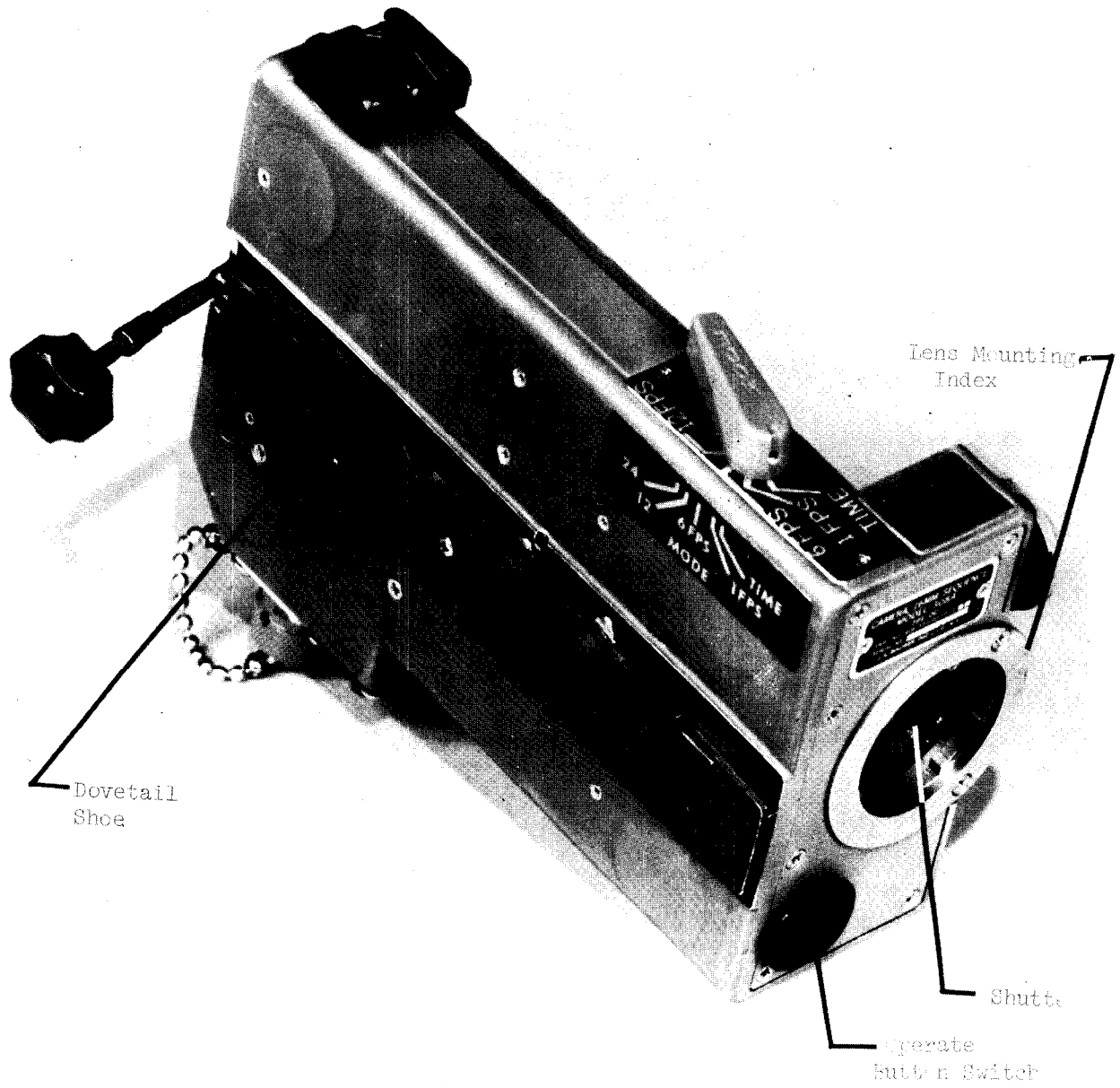

Figure 2.1-1 - Data Acquisition Camera
Back, Top, and Front
View

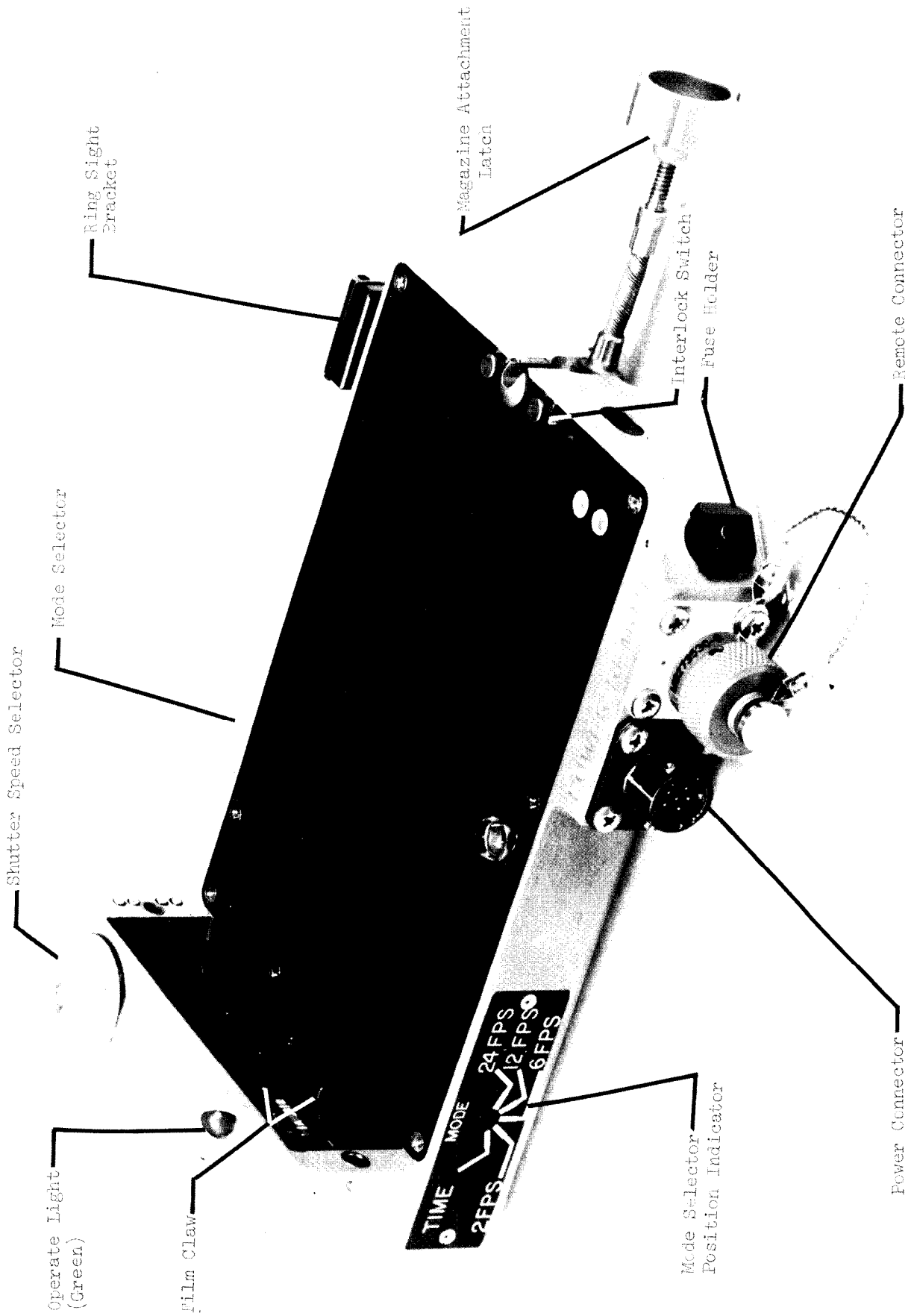

Figure 2.1-2 - Data Acquisition Camera Rear View

24 fps operation starts when front button is depressed and stops when button is released. Green operate light illuminates almost constantly.

TIME exposure is started when front button is depressed and released only if (1) camera was previously stopped by front button method, (2) mode is set to TIME, and (3) shutter speed is set to 1/60 second. Time exposure is ended by depressing and releasing the front button. Green operate light will flash once as the shutter closes.

- Shutter speeds settable to 1/60 (+8%), 1/125 (+ 8%), 1/250 (+ 8%), 1/500 (+ 10%), and 1/1000 (+ 15%) second independently of frame rate.
- Accepts bayonet mount of lenses in four possible orientations. Orange index dot on camera front and on lens base indicate proper orientation for standard usage.
- Accepts DAC Film Magazine (140) (see 2.2) or DAC Transport Mechanism (see 2.3) which uses DAC Film Cassettes (400) (see 2.4).
- An accessory connector (rearmost) is provided for remote operation (ON/OFF and mode selection) with Remote Control Cable (see 2.16). Connector is Deutsch bayonet type UR40-8-7S.
- A shutter operation signal and a magazine identification pulse are available in the power connector for use as a telemetry data source.
- A dovetail mounting rail on the camera permits bracket mounting and the installation of the Universal Mount (see 2.18), the DAC EVA Bracket (see 2.19), or the DAC Handle (see 2.20).
- The accessory shoe accepts the Ring Sight (see 4.15) for precision aiming of long focal length lenses.
- Internal heaters are incorporated and thermostatically controlled to permit camera operation in a low temperature environment.
- The DAC has been successfully qualification tested for use in Skylab and Apollo vehicles, during EVA operations, and on the lunar surface.
- The DAC mean time to maintenance is 200 operating hours and has a life expectancy in excess of 1,000 hours.

2.2 DAC Film Magazine (140) (SEB33100125):

The 16 mm. DAC Film Magazine (140) is the original film magazine for the DAC system. The capacity of this magazine is limited to 140 feet of thin base 16 mm. film.

2.2.1 Significant Configurations:

<u>Configuration</u>	<u>Purpose</u>
-203 or -205	Apollo CM flight unit
-204	Apollo lunar surface flight unit; white thermal coating on lid
-206	Skylab flight unit

2.2.2 Characteristics:

- Manufactured by J. A. Maurer, Inc., Long Island City, New York 11101.
- Weight - 1.0 lb (454 g.) with film.
Envelope - 3.6 x 5.4 x 0.9 in (9.2 x 13.7 x 0.23 cm).
Volume - 17.5 in³ (287 cm³).
- Film capacity of 140 feet (42.7 meters) of thin base film (2.5 mil, 64 μm) provides maximum run durations of 93 min at 1 fps, 46 min at 2 fps, 16 min at 6 fps, 8 min at 12 fps, and 4 min at 24 fps.
- Magazine film must be loaded and unloaded in a photographic darkroom.
- Film usage indicator shows the gross amount of film remaining.
- The red light at the rear of the magazine illuminates when 6 feet (1.8 meter) of film remains. The light remains energized and the camera continues to run when the film supply is depleted.
- This film magazine has been qualified to the same levels as the DAC (see 2.1).

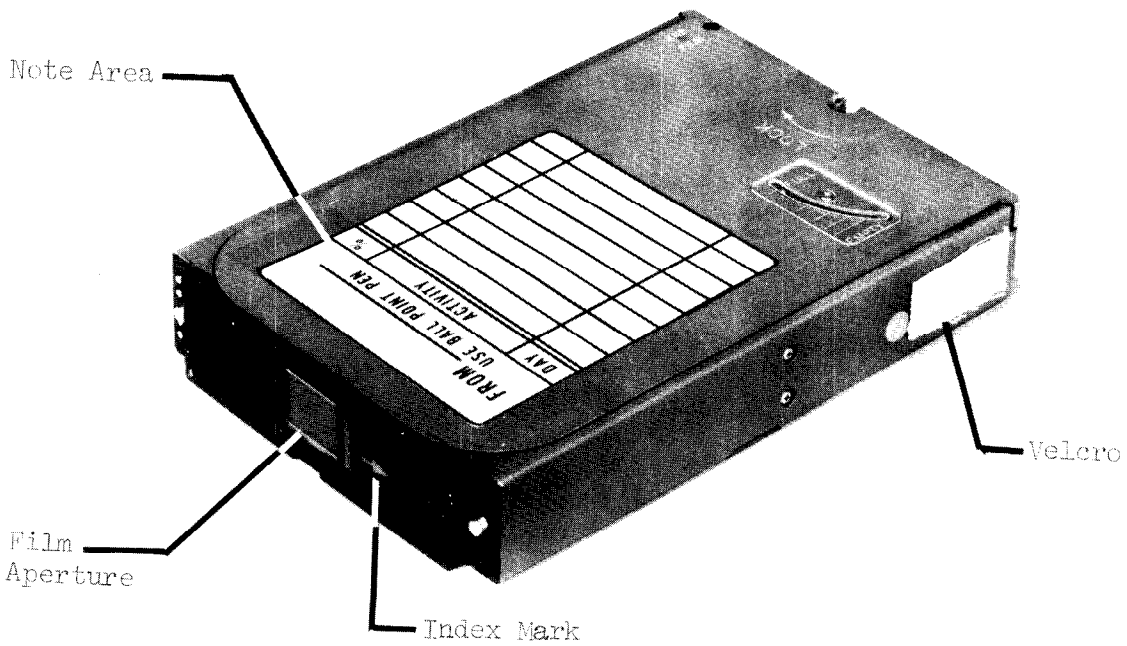
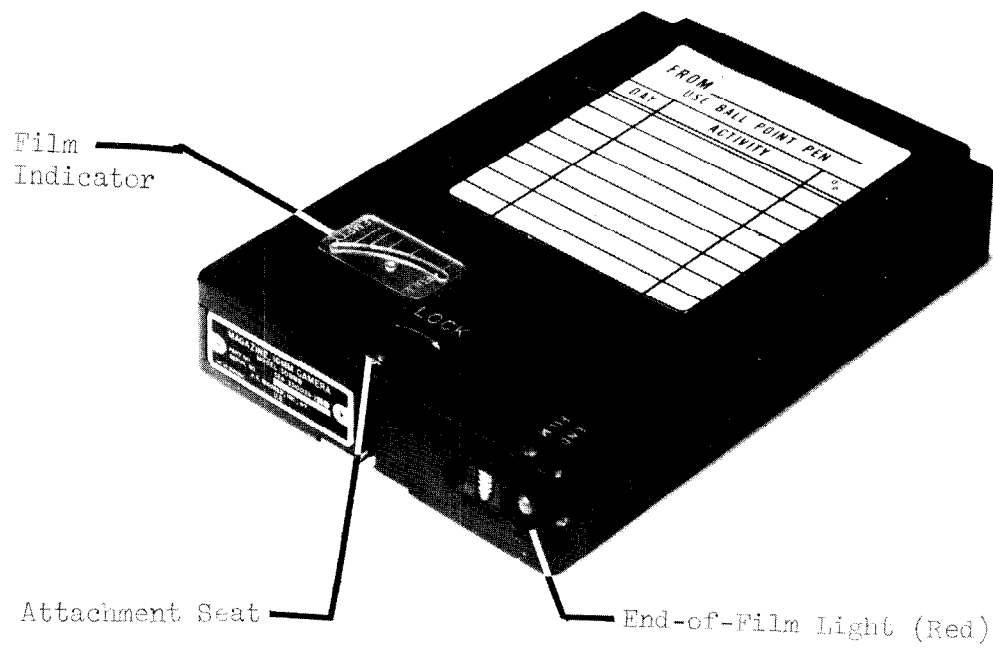

Figure 2.2-1 - DAC Film Magazine (140)

2.2-2

2.3 DAC Transport Mechanism (SEB33100278):

The DAC Transport Mechanism installs on the DAC like a film magazine and provides the threading and positioning for the film from the DAC Film Cassettes (see 2.4). The DAC Transport Mechanism is driven by and receives its framing synchronization from the DAC itself.

2.3.1 Significant Configurations:

<u>Configuration</u>	<u>Purpose</u>
-301	Skylab flight unit

2.3.2 Characteristics:

- Manufactured by J. A. Maurer, Inc., Long Island City, New York 11101.
- Weight - 2.0 lbs (908 g.).
Envelope - 2.0 x 8.2 x 5.4 in (5.1 x 20.8 x 13.7 cm).
Volume - 86.4 in³ (1416 cm³).
- Interfaces with DAC in the same way as the DAC Film Magazine (140) (see 2.2) providing film plane location, electrical interconnection, and slot for magazine attachment latch of DAC.
- Provides for attachment of two DAC Film Cassettes (400) (see 2.4) - one for film supply (toward camera) and one for film take-up. Attachment latches for supply cassette are marked with "S" and for take-up with "TU".
- A two position lever is provided for the selection of "THREAD" and "OPERATE" functions. An amber light illuminates when in the THREAD position.
- The red light at the rear of the mechanism illuminates when no film remains. The light remains energized and the DAC continues to run when the film supply is depleted.
- This transport mechanism has been qualification tested for use in the Skylab vehicles and during EVA operations.

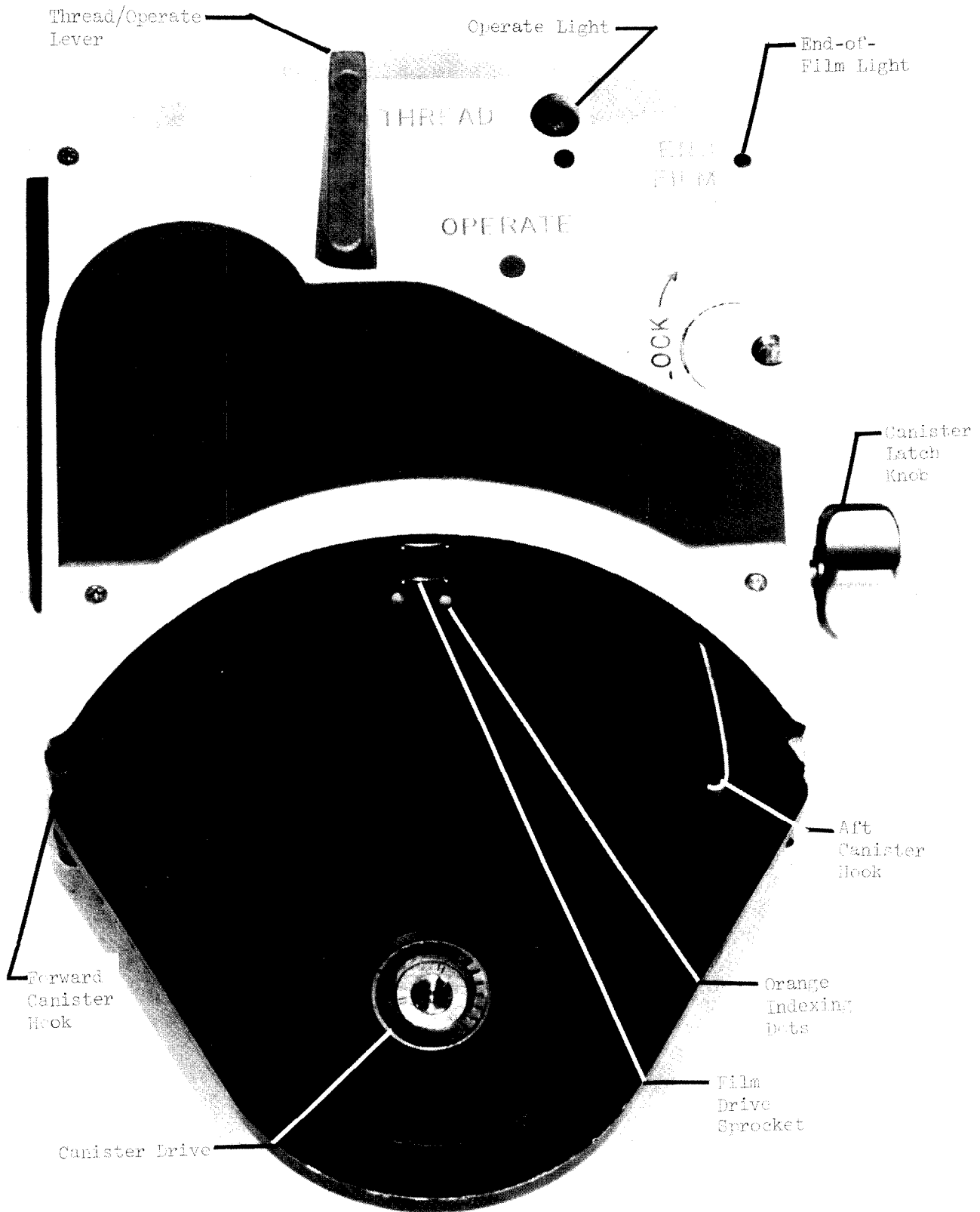

Figure 2.3-1 - DAC Transport Mechanism

2.4 DAC Film Cassette (400) (SEB33100279):

The DAC Film Cassette is the film container for the DAC Transport Mechanism (see 2.3). Two cassettes are required for transport operation - one for film supply and one for take-up. The cassettes are interchangeable and provide the largest film capacity for the DAC system - 400 feet of thin base 16 mm. film.

2.4.1 Significant Configurations:

<u>Configuration</u>	<u>Purpose</u>
-301	Skylab flight unit

2.4.2 Characteristics:

- Manufactured by J. A. Maurer, Inc., Long Island City, New York 11101.
- Weight with film - 1.2 lbs (545 g.)
Weight without film - 0.7 lbs (318 g.).
Envelope - 5.88 dia x 0.88 in (15.0 dia x 2.1 cm).
Volume - 24.0 in³ (392 cm³).
- Film capacity of 400 feet (122 meters) of thin base film (2.5 mil, 64 μm) provides maximum run durations of 267 min at 1 fps, 134 min at 2 fps, 44 min at 6 fps, 22 min at 12 fps, and 11 min at 24 fps.
- Cassette film must be loaded and unloaded in a photographic darkroom.
- Attach to the DAC Transport Mechanism (see 2.3) for use as film supply and as film take-up.
- Film usage indicator has markings at every 10 percent of capacity showing the gross amount of film remaining.
- The DAC Film Cassette has been qualification tested for use in the Skylab vehicles and during EVA operations.

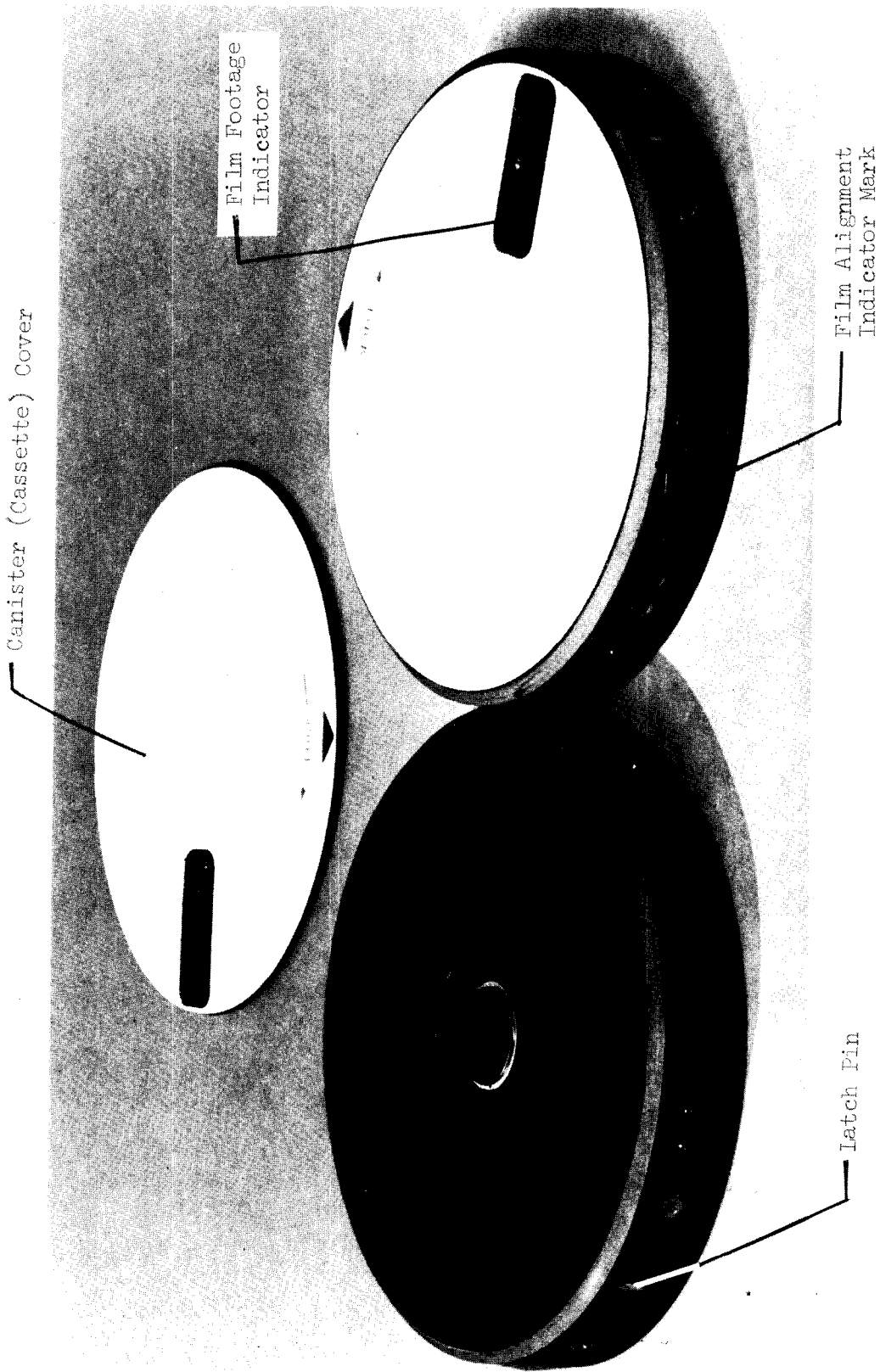

Figure 2.4-1 - DAC Film Cassette (400)

2.4-2

2.5 5 mm. Lens (SEB33100056):

This is the widest field-of-view lens available for the DAC system. It is used primarily for interior photography when maximum area coverage is desired and where detail and geometrical fidelity are less important. Even though the barrel distortion effects of this lens are minimal for a lens of such short focal length, the effects are noticeable.

2.5.1 Significant Configurations:

<u>Configuration</u>	<u>Purpose</u>
-208	Apollo and Skylab flight unit

2.5.2 Characteristics:

- Manufactured by Fairchild Space and Defense Systems, Inc., El Segundo, California 90245.
- Weight with cover - 0.69 lbs. (313 g.).
Envelope (less tab) - 2.14 dia. x 3.02 in. (5.34 dia x 7.67 cm.).
Volume - 10.1 in.³ (178.0 cm.³).
- Field-of-view - 117.5° x 80.2°; 160° diagonal.
- Focus is fixed and good from the front of the lens to infinity.
- Aperture - f/2.0 to f/16 with detents at each full-stop value. A sturdy tab is provided to assist in aperture ring setting and in lens installation and removal.
- Lens cover is part of lens assembly and protects front glass surface.
- This lens has been qualification tested for use in the Skylab and Apollo vehicles and during EVA operations.

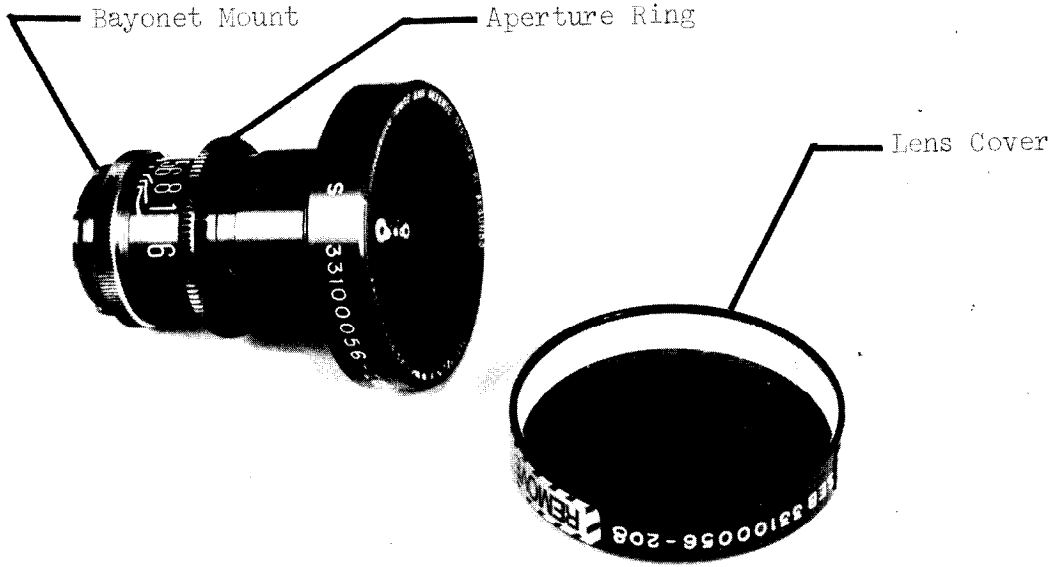

-208

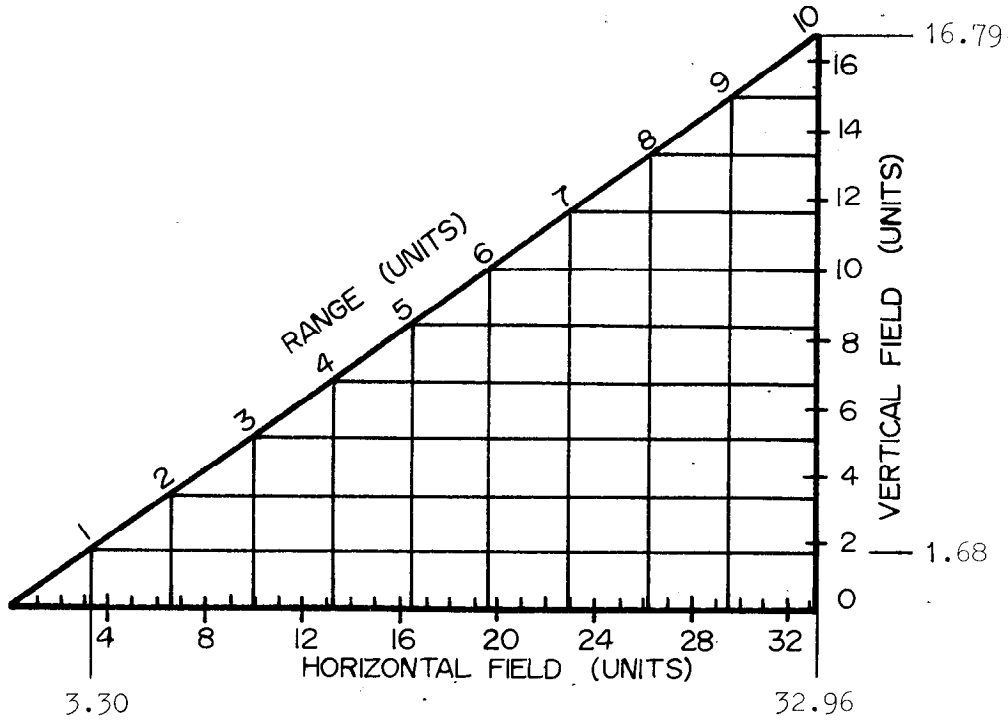

Figure 2.5-1 - 5 mm. Lens and Field-of-View Chart

2.5-2

2.6 10 mm. Lens (SEB33100010):

The 10 mm. Lens has a wide field-of-view, a large relative aperture, and very good resolution and distortion characteristics. The lens is most useful for interior vehicle photography where illumination is low and where moderate engineering detail is to be recorded. The low distortion property of this lens has made it well suited for recording EVA and lunar surface operations also.

2.6.1 Significant Configurations:

<u>Configuration</u>	<u>Purpose</u>
-301	Skylab and Apollo CM flight unit
-302	Apollo LM flight unit; narrow teflon lens shade
-303	Apollo lunar surface unit; no focus tab and focus fixed at 6 feet with tape

2.6.2 Characteristics:

- Manufactured by Kern and Co. AG, Aarau, Switzerland, and distributed by Paillard, Inc., Linden, New Jersey 07036.
- Weight - 0.60 lbs. (272 g.).
Envelope (less tabs) - 1.97 dia. x 2.03 in. (5.0 dia x 5.16 cm.)
Volume - 6.18 in.³ (101.3 cm.³)
- Field-of-view - 54.9° x 41.1°; 65.2° diagonal.
- Focus range - 8 inches to infinity with detents and markings for 2 feet and infinity and with only markings for 8, 9, and 10 inches and for 1, 1.5, 3, and 6 feet. The 2 foot setting provides sharp focus to infinity for aperture settings for T/5.6 through T/22. At the closest focus setting, the subject should be 4.7 inches (11.9 cm.) from the lens front edge.
- Aperture - T/1.8 through T/22 with detents at each full stop value.
- Sturdy tabs are provided on the aperture and focus rings to assist in setting and in lens installation and removal.

- This lens has been qualification tested for use in the Skylab and Apollo vehicles, on the lunar surface, and during EVA operations.

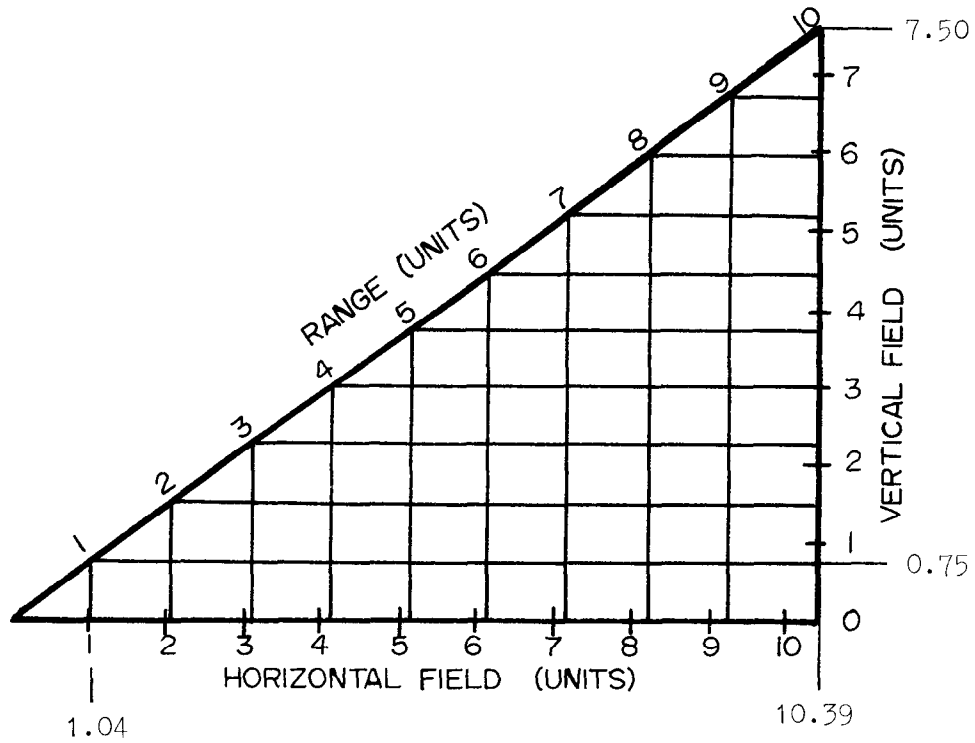
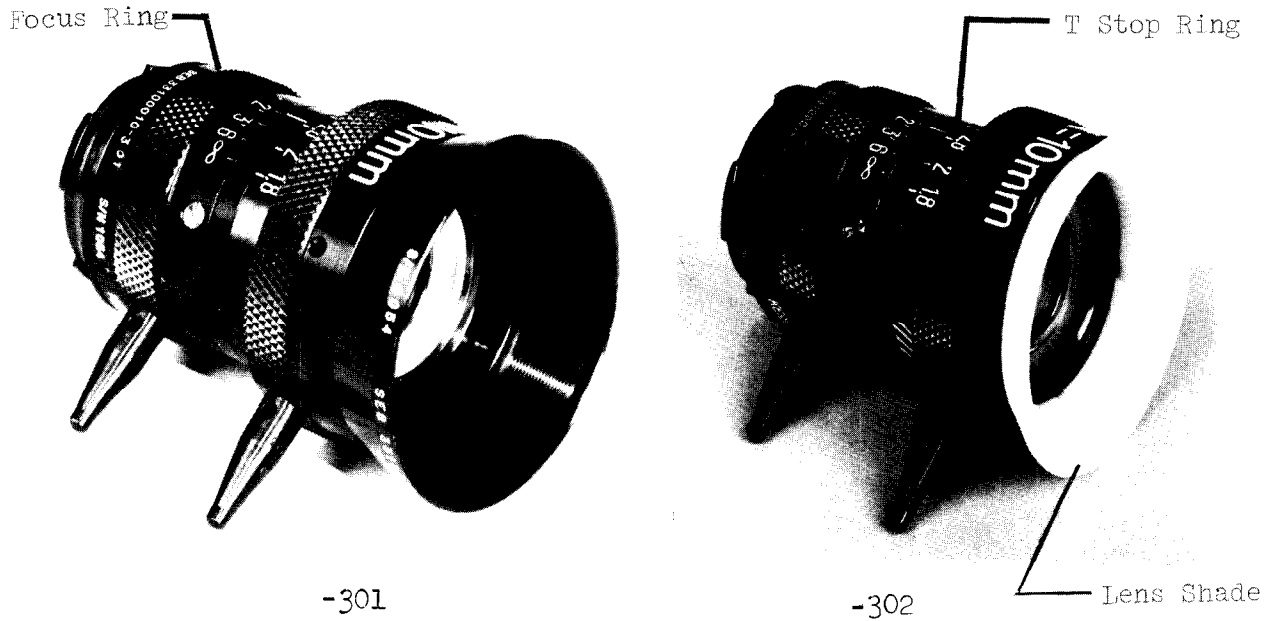

Figure 2.6-1 - 10 mm. Lens and Field-of-view Chart

2.7 18 mm. Lens (SEB33100018):

The 18 mm. Lens has the largest relative aperture of the DAC system and is the widest field-of-view lens that can be used with the Right Angle Mirror (see 2.12). The lens is especially useful for vehicle-to-vehicle docking and detailed interior photography.

2.7.1 Significant Configurations:

<u>Configuration</u>	<u>Purpose</u>
-301	Apollo and Skylab flight unit; standard mirror interface
-302	Skylab Exp. T020 unit; no mirror interface and no control tabs
-303	Skylab Exp. M479 unit; rotated mirror interface and no control tabs

2.7.2 Characteristics:

- Manufactured by Kern and Co. AG, Aarau, Switzerland, and distributed by Paillard, Inc., Linden, New Jersey 07036.
- Weight - 0.80 lbs. (364 g.).
Envelope (less tabs) - 2.14 dia x 2.60 in. (5.43 dia x 6.60 cm.).
Volume - 9.36 in.³ (153 cm.³).
- Field-of-view - 32.6° x 23.4°; 39.2° diagonal.
- Focus range - 1 foot to infinity with detents and markings for 10 feet and infinity and with only markings for 1, 1.5, 2, 3, and 5 feet. The 10 foot setting provides sharp focus to infinity for aperture settings of T/4 through T/22. At the closest focus setting, the subject should be 8.9 inches (22.6 cm.) from the lens front edge.
- Aperture - T/1.0 through T/22 with detents at each full stop value.
- Sturdy tabs are provided on the aperture and focus rings to assist in setting and in lens installation and removal. (Except -302 and -303 configurations, see 2.7.1.)
- Accepts attachment of the Right Angle Mirror (see 2.7.1 and 2.12).

• This lens has been qualification tested for use in the Skylab and Apollo vehicles and during EVA operations.

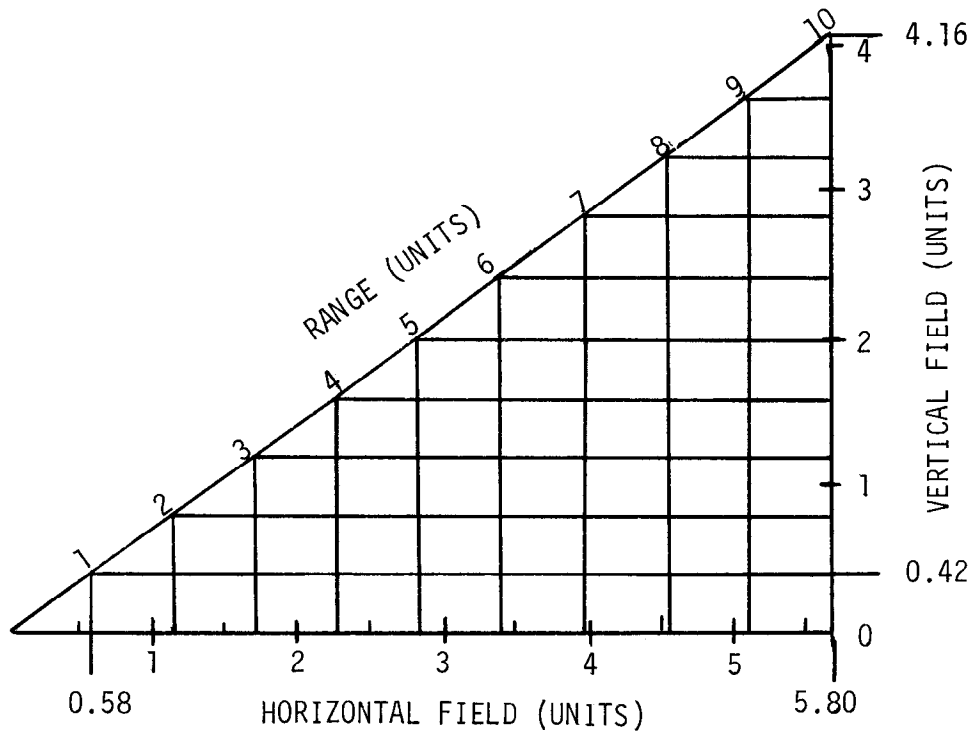
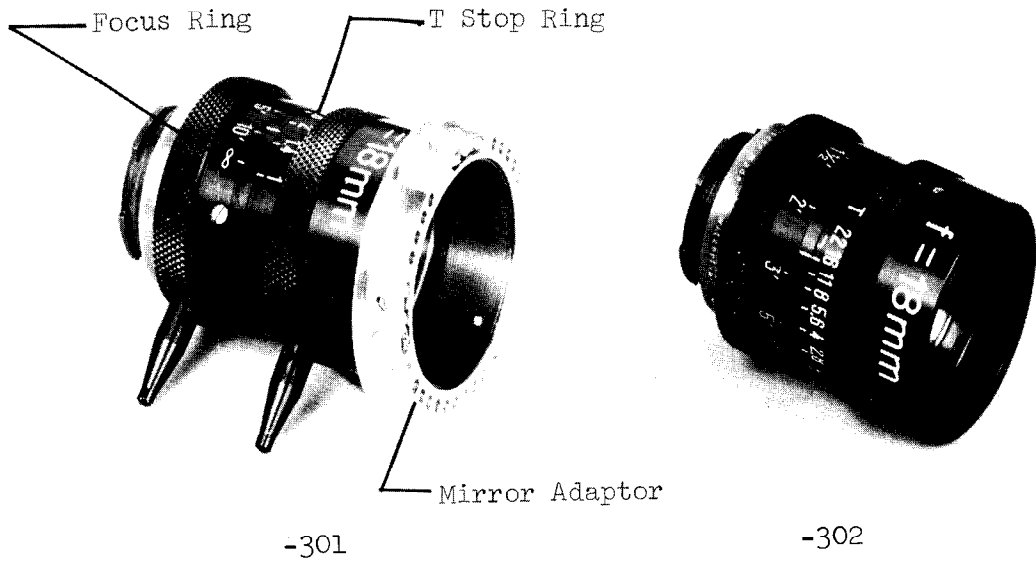

Figure 2.7-1 - 18 mm. Lens and Field-of-view Chart

2.8 25 mm. Lens (SEB33100054):

This focal length lens is the standard for 16 mm. photography providing the "normal" visual scene coverage. The large relative aperture of this lens is especially useful for dimly lighted photographic situations.

2.8.1 Significant Configurations:

<u>Configuration</u>	<u>Purpose</u>
-202	Basic flight unit; incorporated in Skylab Experiment T027 assembly.

2.8.2 Characteristics:

- Manufactured by P. Angenieux, Paris, France.
- Weight - 0.30 lbs. (136 g.).
Envelope - 1.64 dia x 2.11 in. (4.17 dia x 5.30 cm.).
Volume - 4.46 in.³ (73.0 cm.³).
- Field-of-view - 23.5° x 17.1°; 28.7° diagonal.
- Focus range - 18 inches to infinity with no detents provided. Focus is marked for 18, 21, 24, 27, 30, 36, and 42 inches and for 4, 5, 7, 10, 15, and 30 feet and for infinity.
- Aperture - f/0.95 (T/1.05) through f/22 with detents at each full stop value.
- This lens has been qualification tested for use in the Gemini and the Skylab vehicles.

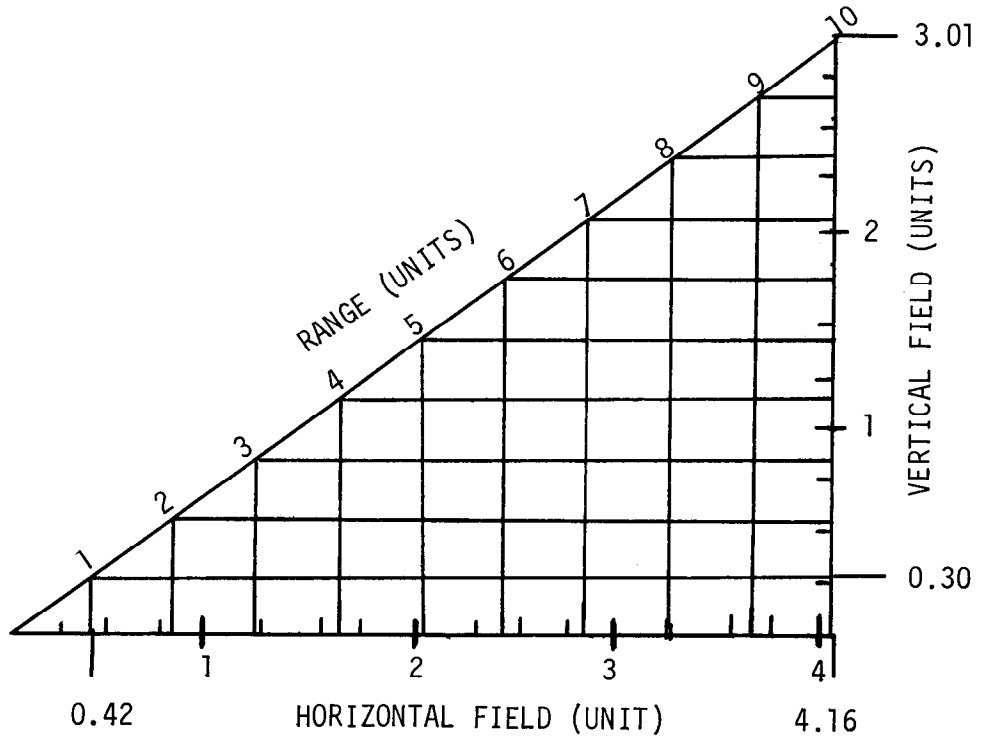
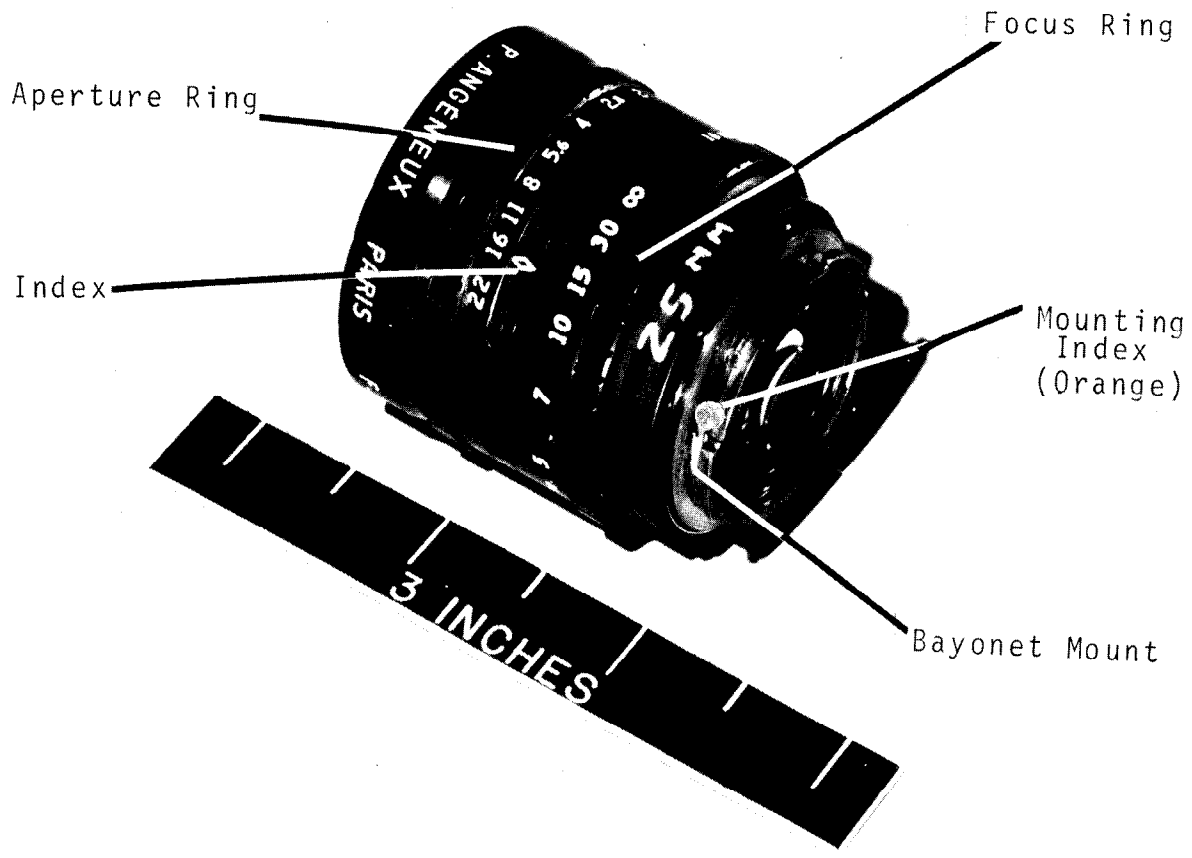

Figure 2.8-1 - 25 mm. Lens and Field-of-View Chart

2.9 75 mm. Lens (SEB33100019):

This moderate telephoto lens is used primarily for photographing distant objects. With the focal length and narrow field-of-view of this lens, bracket mounting and precise aiming are recommended.

2.9.1 Significant Configurations:

<u>Configuration</u>	<u>Purpose</u>
-302	Apollo and Skylab CM unit; standard usage
-303	Skylab Exp. M551-5 unit; extender for close focus incorporated and no control tabs

2.9.2 Characteristics:

- Manufactured by Kern and Co. AG, Aarau, Switzerland, and distributed by Paillard, Inc., Linden, New Jersey 07036.
- Weight (-302) - 0.85 lbs. (386 g.).
(-303) - 0.90 lbs. (409 g.).
Envelope (less tabs) (-302) - 2.14 dia x 3.53 in.
(5.34 dia x 8.96 cm.).
(-303) - 2.14 dia x 4.47 in.
(5.34 dia x 11.35 cm.).
Volume (-302) - 12.7 in.³ (208 cm.³).
(-303) - 16.1 in.³ (264 cm.³).
- Field-of-view (-302) - 8.0° x 5.6°; 10.0° diagonal.
(-303) - 6.0° x 4.4°; 7.4° diagonal.
- Focus range (-302) - 5 feet to infinity with detents and markings for 10 feet and infinity and with only markings for 5, 5.5, 6, 6.5, 7, 8, 9, 12, 15, 20, 30, 50, and 100 feet. The 10 foot setting provides sharp focus from 8.9 to 11.4 feet for T/8 and from 8.5 to 12.1 feet for T/11.
(-303) - 13.4 to 14.9 inches from the film plane with detents at the 14.4 and the 14.9 inch ranges. The focus scale markings are unchanged from the -302 configuration; the incorporated extender of the -303 configuration produces the close-up focusing characteristics.

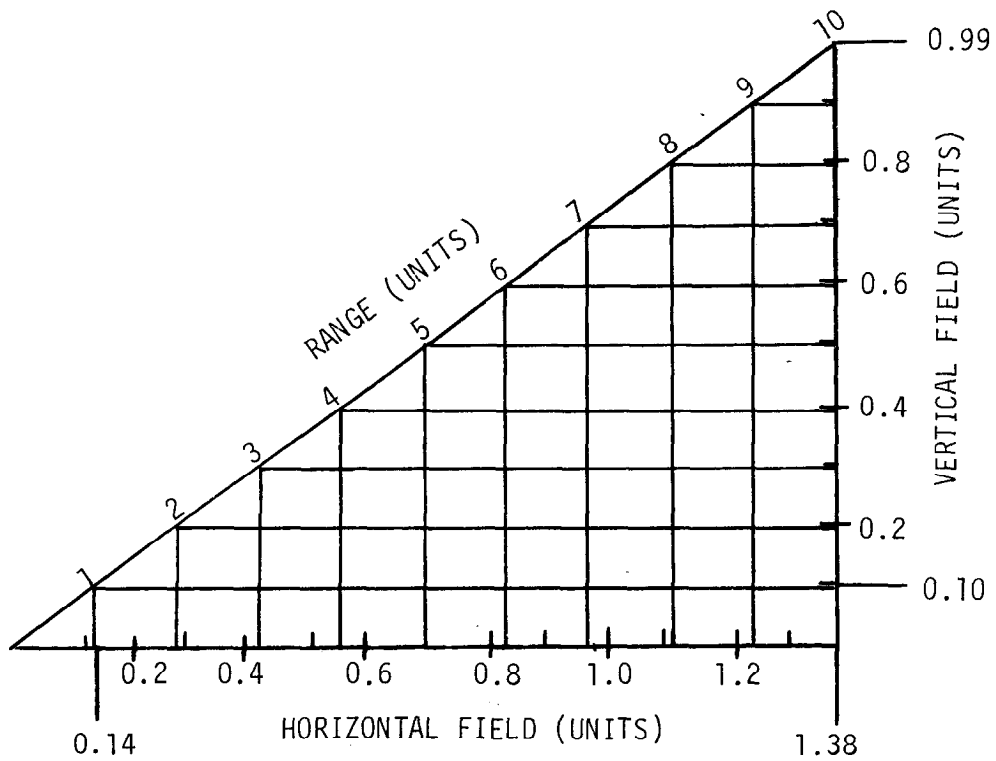
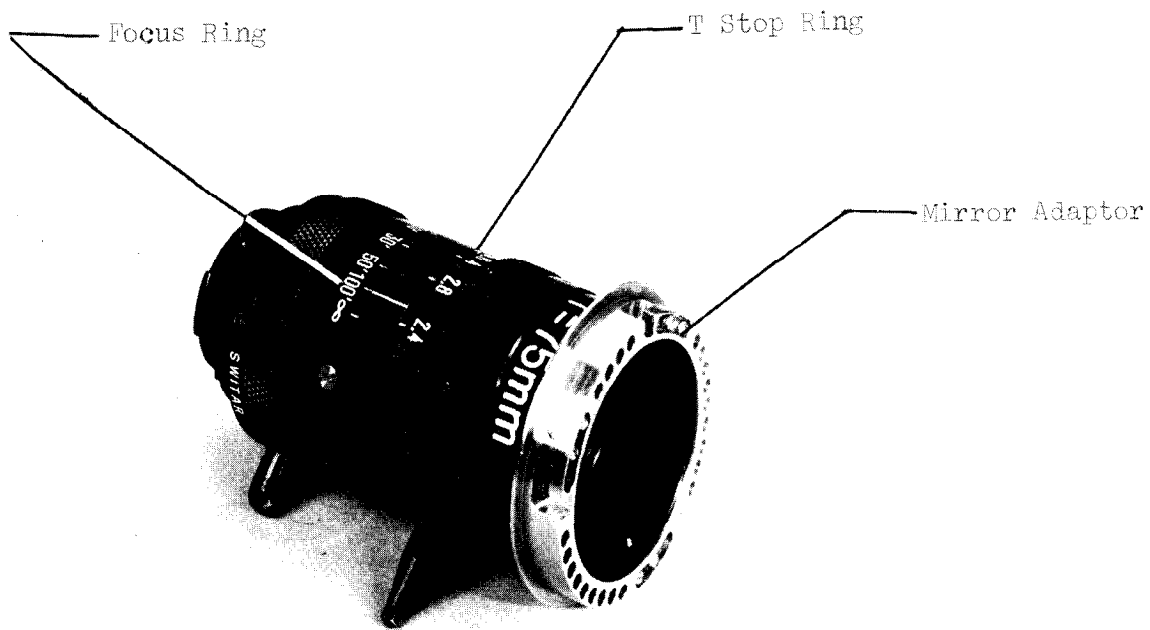

Figure 2.9-1 - 75 mm. Lens (-302) and Field-of-view Chart

- Aperture (-302) - T/2.4 through T/22 with detents at each full stop and at the T/2.4 setting.
 (-303) - marked the same as the -302 configuration; however, the relative aperture is reduced by 0.6 stop because of the lens extension. The marked aperture values are actually the aperture values as follows: T/2.4 is T/3.1, T/2.8 is T/3.6, T/4 is T/5.2, T/5.6 is T/7.3, T/8 is T/10.4, T/11 is T/14.3, T/16 is T/20.8, and T/22 is T/28.6.
- Sturdy tabs are provided (-302 only) on the aperture and focus rings to assist in setting and in lens installation and removal.
- Accept attachment of the Right Angle Mirror (see 2.12).
- This lens has been qualification tested for use in the Skylab and Apollo vehicles and during EVA operations.

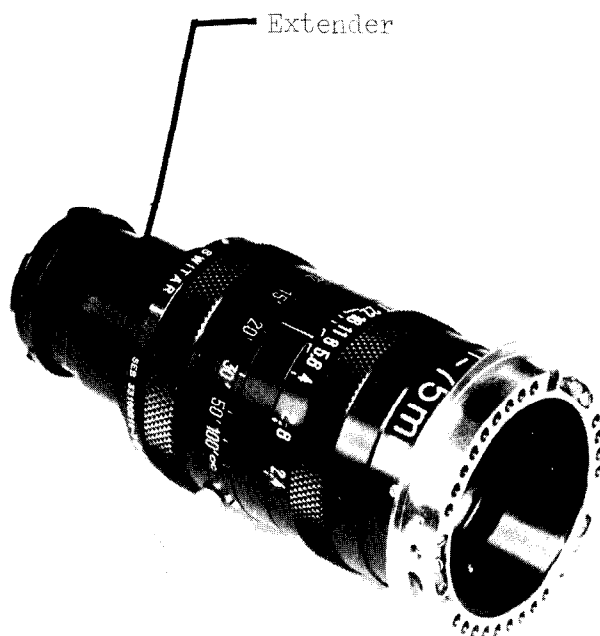

Figure 2.9-2 - 75 mm. Lens (-304) With Incorporated Extender For Close Focus

2.10 100 mm. Lens (SEB33100025):

The 100 mm. Lens is intended for distant object photography. With an extender tube incorporated on the rear of the lens, close range photography is made possible. The long focal length and narrow field-of-view of this lens necessitate bracket mounting and precise aiming. This is a commercial lens and will not be utilized after Skylab.

B

2.10.1 Significant Configurations:

<u>Configuration</u>	<u>Purpose</u>
-202	Standard usage unit
-203	Skylab Exp. M551-5 unit; extender for close focus incorporated

2.10.2 Characteristics:

- Manufactured by Schneider Optische Werke, Kreuznach, W. Germany, and distributed by Burleigh Brooks, Inc., Englewood, New Jersey 07631.
- Weight (-202) - 1.12 lbs. (508 g.).
(-203) - 1.22 lbs. (554 g.).
Envelope (-202) - 2.14 dia x 4.40 in. (5.34 dia x 11.18 cm.).
(-203) - 2.14 dia x 5.80 in. (5.34 dia x 14.72 cm.).
Volume (-202) - 15.8 in.³ (259 cm.³).
(-203) - 20.1 in.³ (343 cm.³).
- Field-of-view (-202) - 5.9° x 4.3°; 7.3° diagonal.
(-203) - 4.3° x 3.1°; 5.4° diagonal.
- Focus range (-202) - 5 feet to infinity with no detented settings. Focus is marked for 6, 6.5, 7, 7.5, 8, 8.5, 9, 10, 11, 12, 14, 16, 18, 20, 25, 30, 40, 50, and 100 feet and for infinity.
(-203) - 20.0 to 21.7 inches from the film plane. The focus scale markings are unchanged from the -202 configuration; the incorporated extender of the -203 configuration produces the close-up focusing characteristics. Focus is locked at proper distance for experiments.
- Aperture (-202) - f/2.8 through f/32 with no detents.
(-203) - marked the same as the -202 configuration; however, the relative aperture is reduced by 0.7 stop because of the lens extension. The marked aperture values are actually the aperture values as follows: f/2.8 is f/3.8, f/4 is f/5.4, f/5.6 is f/7.6, f/8 is f/10.8, f/11 is f/15, f/16 is f/21, f/22 is f/30, and f/32 is f/43.

B

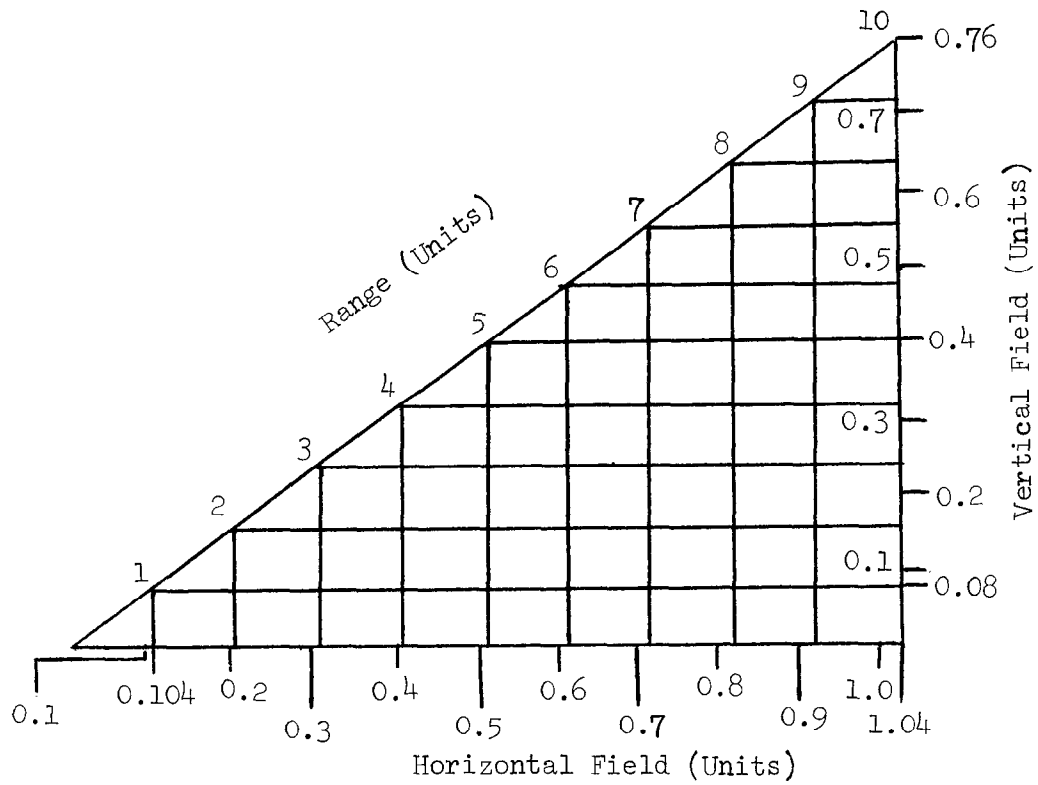
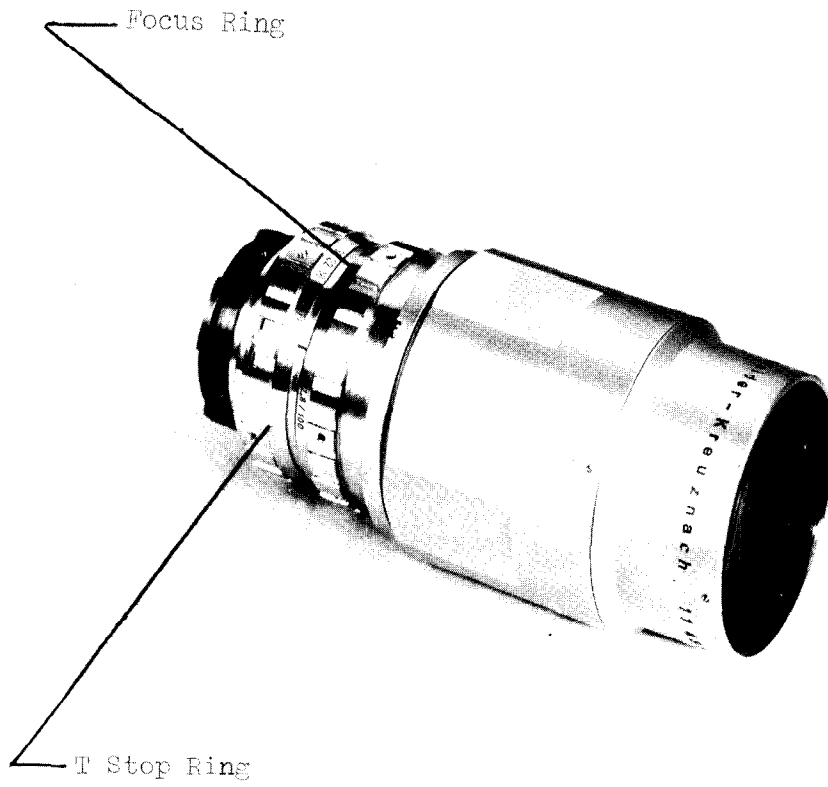

Figure 2.10-1 - 100 mm. Lens (-202) and Field-of-view Chart

- Accepts attachment of the Right Angle Mirror (see 2.12).
- This lens has been qualification tested for use in the Skylab and Apollo vehicles

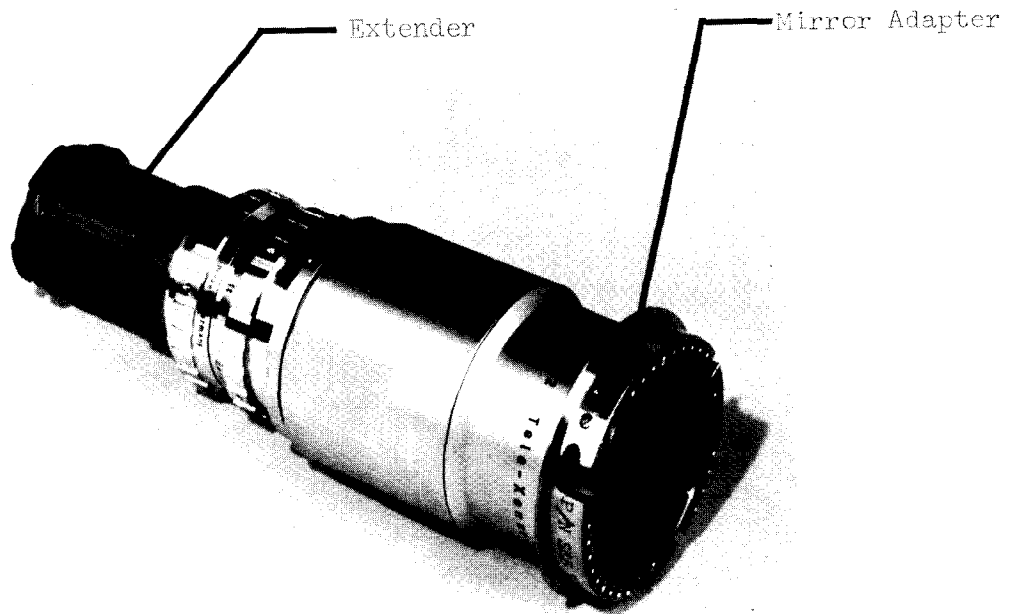

Figure 2.10-2 - 100 mm. Lens (-203) with Incorporated Extender for Close Focus

2.11 180 mm. Lens (SEB33100017):

The 180 mm. Lens is the longest focal length lens available in the DAC system. Its primary use is for distant object photography. The very long focal length and narrow field-of-view of this lens necessitate bracket mounting and precise aiming.

2.11.1 Significant Configurations:

<u>Configuration</u>	<u>Purpose</u>
-301	Basic flight unit - not currently in use

2.11.2 Characteristics:

- Manufactured by Kern and Co. AG, Aarau, Switzerland, and distributed by Paillard, Inc., Linden, New Jersey 07036.
- Weight - 1.36 lbs. (618 g.).
Envelope (less tabs) - 2.14 dia x 6.53 in (5.34 dia x 16.60 cm.).
Volume - 23.5 in.³ (385 cm.³).
- Field-of-view - 3.3° x 2.4°; 4.1° diagonal.
- Focus range - 15 feet to infinity with no detented settings. Focus is marked for 15, 16, 18, 20, 25, 30, 35, 40, 50, 70, 100, and 200 feet and for infinity.
- Aperture - T/4.6 to f/32 with a detent at each full stop and at the T/4.6 setting.
- Sturdy tabs are provided on the aperture and focus rings to assist in setting and in lens installation and removal.
- Accepts attachment of the Right Angle Mirror (see 2.12).
- This lens has been qualification tested for use in the Skylab and Apollo vehicles and during EVA operations.

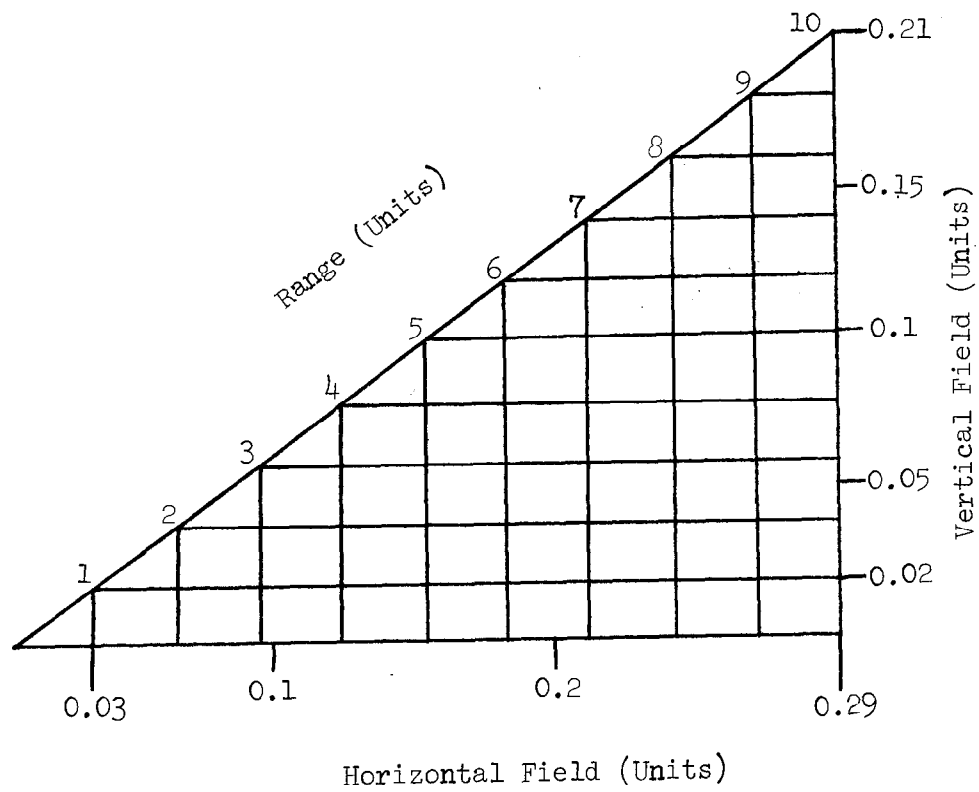
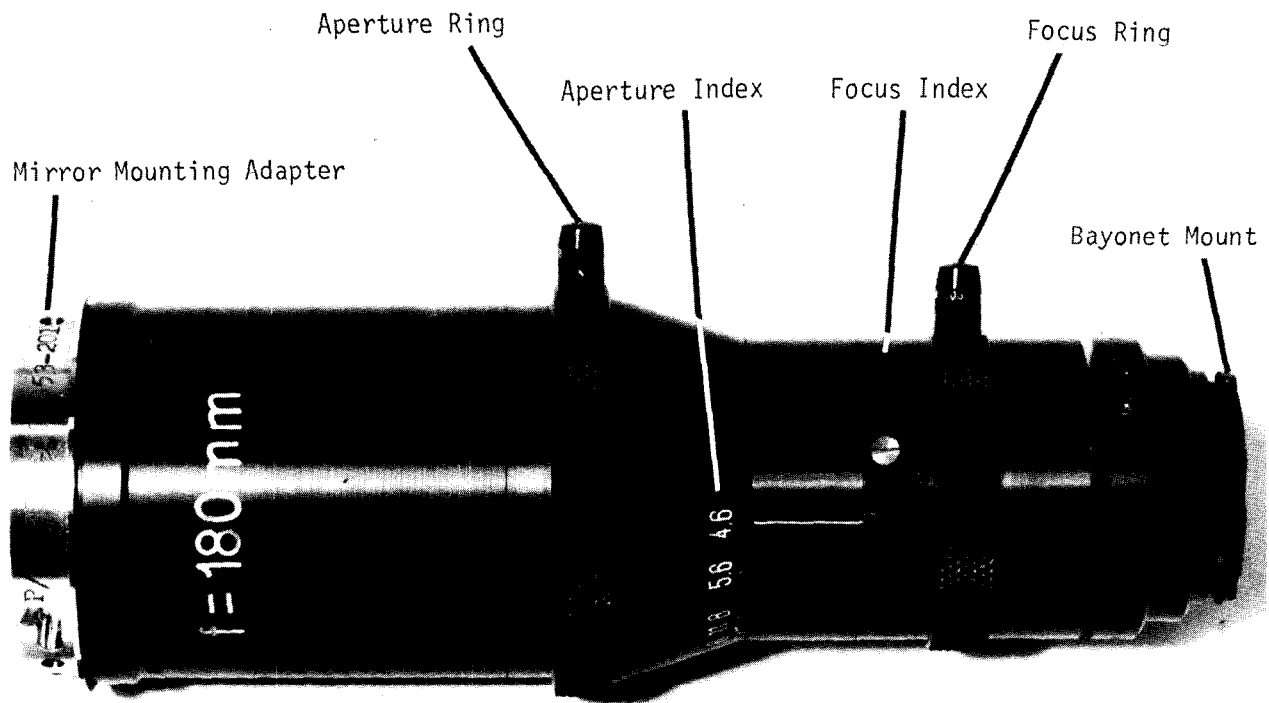

Figure 2.11-1 - 180 mm. Lens and Field-of-view Chart

2.12 Right Angle Mirror (SEB33100051):

The Right Angle Mirror assembly bayonet mounts onto the front of several of the DAC lenses for photographic coverage at a right angle to the lens optical axis.

2.12.1 Significant Configuration:

<u>Configuration</u>	<u>Purpose</u>
-205	Apollo and Skylab flight unit

2.12.2 Characteristics:

- Manufactured by Technical Services Division, NASA MSC, Houston, Texas 77058.
- Weight - 0.16 lbs. (72.6 g.).
Envelope - 2.14 dia x 2.2 in. (5.34 dia x 5.59 cm.).
Volume - 7.92 in.³ (130 cm.³).
- Mirror is a front surface polished glass plate, silvered for maximum optical reflectance and protected by an aluminum with silicone monoxide coating.
- Bayonet mounting is indexed and installs on the lens in only one orientation. Can be installed on the 18 mm. Lens (see 2.7), 75 mm. Lens (see 2.9), 100 mm. Lens (see 2.10), and 180 mm. Lens (see 2.11).
- The Right Angle Mirror has been qualified for use in the Skylab and Apollo vehicles.

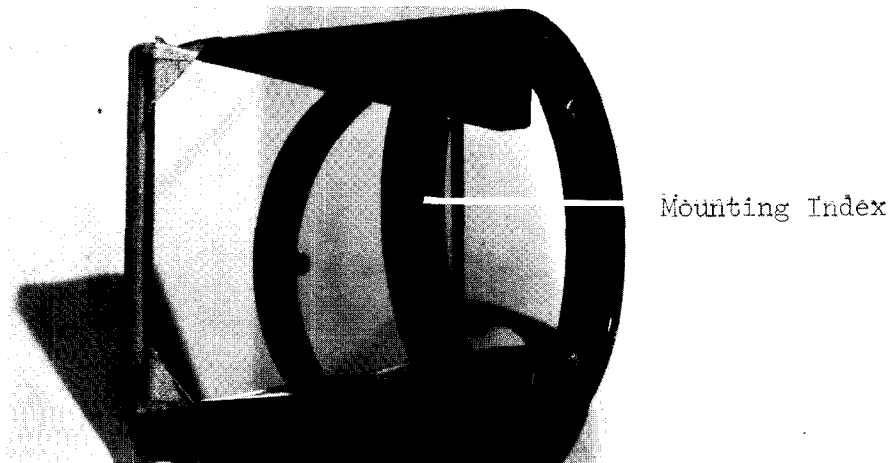

Figure 2.12-1 - Right Angle Mirror



2.13 DAC Power Cable (CM) (SEB33100038):

This cable is used in the CM to provide spacecraft power to the DAC.

2.13.1 Significant Configurations:

<u>Configuration</u>	<u>Purpose</u>
-301	CM flight unit for Apollo and Skylab missions

2.13.2 Characteristics:

- Manufactured by Technical Services Division, NASA MSC, Houston, Texas 77058.
- Weight - 0.23 lbs (104.3 g.).
Length - 108 ± 4 in. (9 ± 0.3 ft.) (274 ± 10 cm.).
- Connects DAC to CM Panels 15, 16, and 100.
- This three wire cable includes a Bendix type JT06P-8-6S bayonet connector on the DAC end and a Deutsch type 127-3-9P push-pull connector on the CM end.
- This cable has been qualified for use in the Skylab and Apollo vehicles.

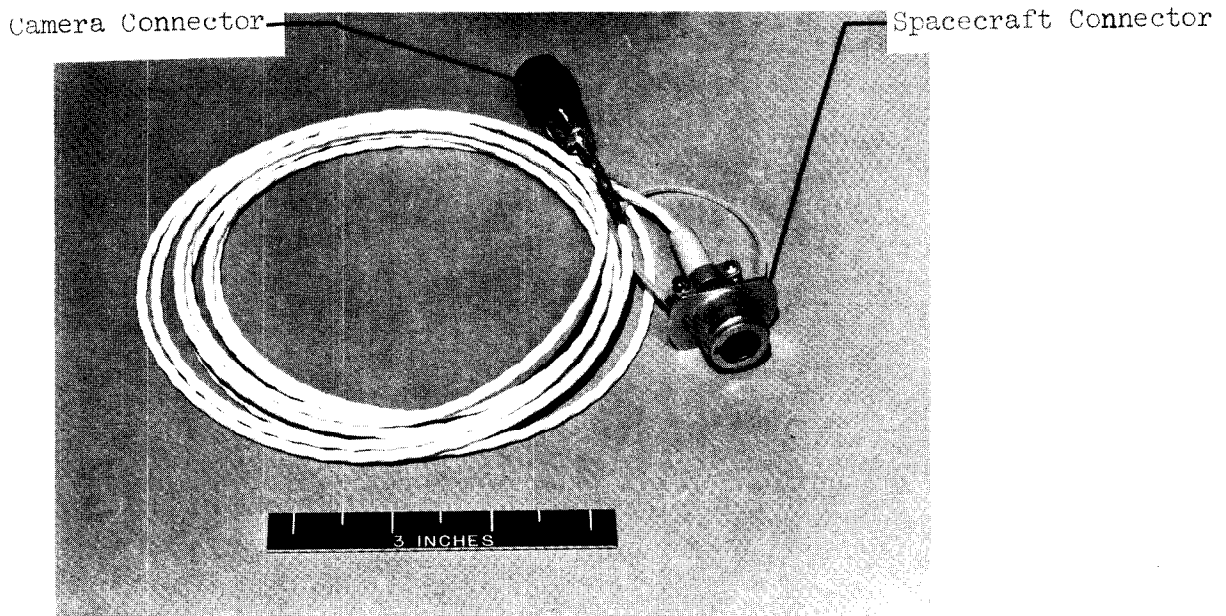
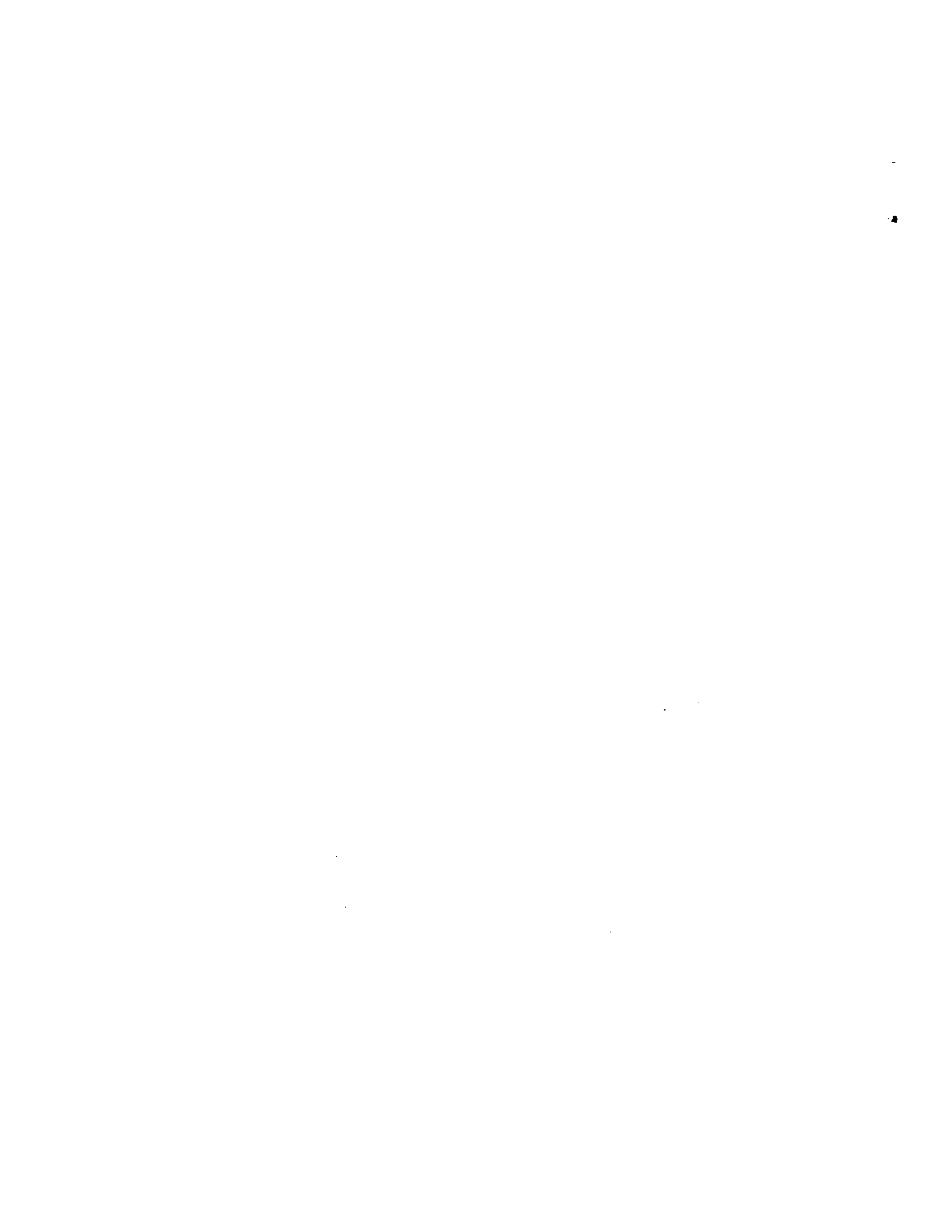

Figure 2.13-1 - DAC Power Cable (CM)



2.14 DAC Power Cable (SWS) (SEC33100567):

This cable is used in the Skylab OWS and MDA to provide power to the DAC.

2.14.1 Significant Configurations:

<u>Configuration</u>	<u>Purpose</u>
-303	Skylab flight unit

2.14.2 Characteristics:

- Manufactured by Technical Services Division, NASA MSC, Houston, Texas 77058.
- Weight - 1.0 lbs. (454 g.).
Length - 180 ± 0 in. (15 ± 0.5 ft.) (457 ± 15 cm.).
- Connects the DAC to the OWS utility outlets.
- This three wire shielded cable includes a Bendix type JTO6P-8-6S bayonet connector on the DAC end and a Bendix type ZG6E1511-98-PA zero g connector on the SWS end.
- This cable has been qualified for use in the Skylab vehicles.

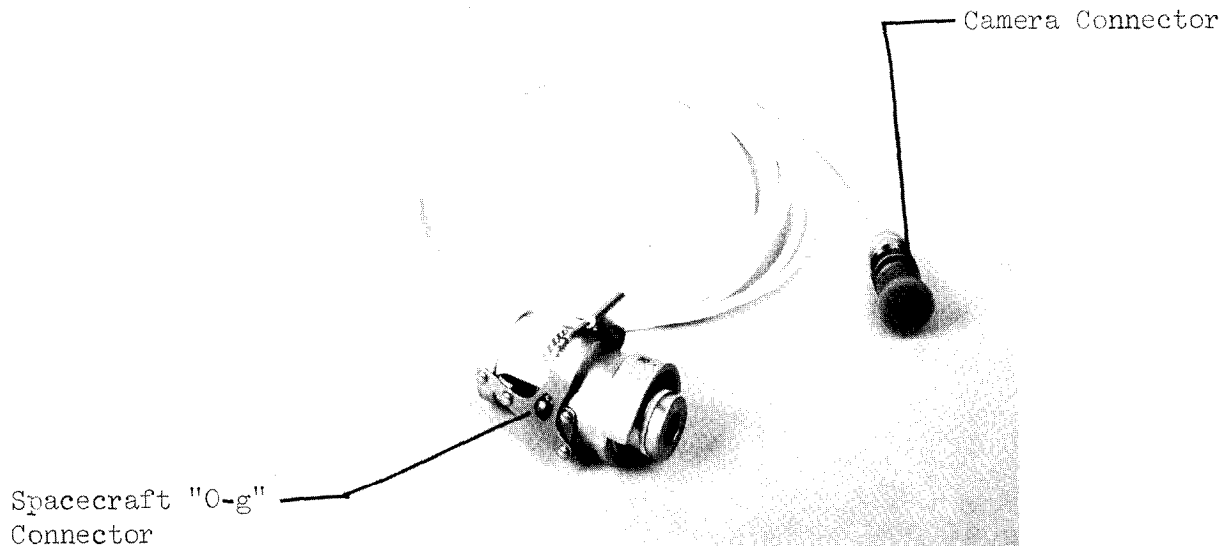

Figure 2.14-1 - DAC Power Cable (SWS)

2.15 DAC Spare Fuse Assembly (SEB33100266):

The Spare Fuse Assembly includes a replacement power line fuse for the DAC and a fuse pin protector in a small teflon bag.

2.15.1 Significant Configurations:

<u>Configuration</u>	<u>Purpose</u>
-301	Apollo and Skylab flight unit

2.15.2 Characteristics:

- The assembly is prepared by the Flight Crew Integration Division, NASA MSC, Houston, Texas 77058. The actual fuse is provided by J. A. Maurer, Inc., Long Island City, New York 11101.
- Weight - 0.01 lbs. (4.5 g.).
Envelope - 1.7 x 1.2 x 0.5 in. (4.3 x 3.0 x 1.3 cm.).
Volume - 1.02 in.³ (16.7 cm.³).
- The fuse rating can be either 1.5 or 2.0 amp. with standard opening characteristics. There is no visible indication of fuse opening.
- The DAC Spare Fuse Assembly has been qualified for use in the Apollo and Skylab vehicles.

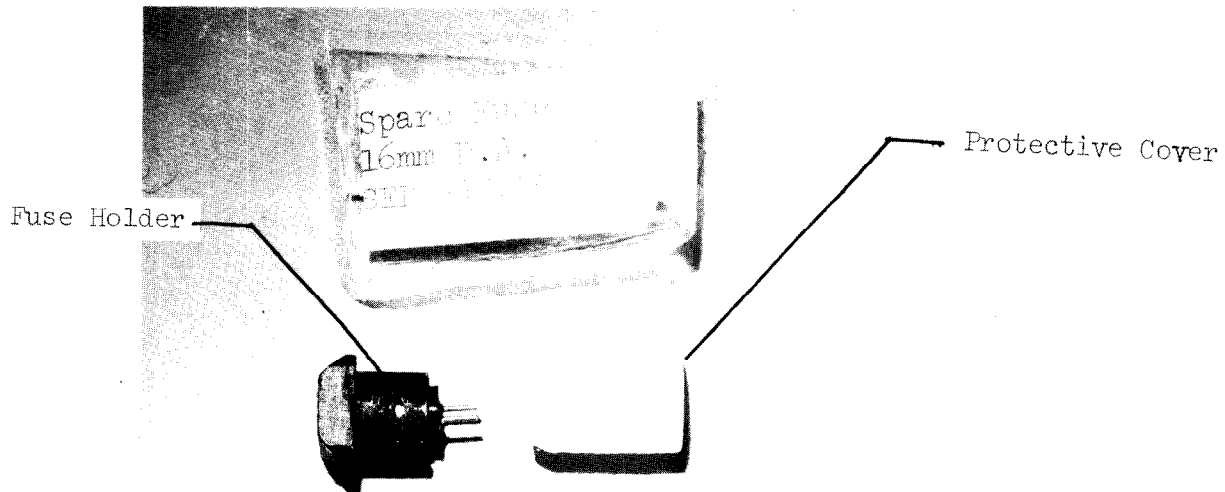

Figure 2.15-1 - DAC Spare Fuse Assembly

2.16 Remote Control Cable (SEB33100020):

This cable provides for remote operation of the DAC and Hasselblad cameras.

2.16.1 Significant Configurations:

<u>Configuration</u>	<u>Purpose</u>
-301	Apollo CM; indicator light in cable button
-302	Apollo LM; indicator light in cable button
-303	Apollo; without indicator light
-305	Skylab flight unit

2.16.2 Characteristics:

- Manufactured by J. A. Maurer, Inc., Long Island City, New York 11101.

<u>Configuration</u>	<u>Weight</u>	<u>Length</u>
-301	1.0 lbs. (454 g.)	120 ₋₂ in. (304 ₋₅ cm.).
-302	1.4 lbs. (636 g.)	168 ₋₂ in. (426 ₋₅ cm.).
-303	0.7 lbs. (318 g.)	48 ₋₂ in. (122 ₋₅ cm.).
-305	1.3 lbs. (591 g.)	240 ₋₈ ⁶ in. (609 ₋₁₀ ¹⁵ cm.).

- Cable incorporates a Deutsch type UR46-8-7P bayonet connector for attachment to the DAC or the Hasselblad camera accessory connector.
- For DAC control, the camera operation can be started and stopped and the camera sequencing modes can be selected as follows:

<u>Configuration</u>	<u>Sequencing Modes</u>
-301	1, 6, 12, and 24 fps
-302	1, 6, 12, and 24 fps
-303	Time, 1, 6, 12, and 24 fps
-305	Time, 2, 6, 12, and 24 fps

Remote mode selection is independent of camera mode selector switch setting. The camera operating mode is

determined by which operate button is used to start the sequencing. DAC automatic operation can be stopped by depressing and releasing either operate button.

- For Hasselblad camera control, only camera actuation can be triggered with the cable button. Remote mode selector setting has no effect in this case.
- The cable configurations -301 and -302 incorporate an indicator lamp under the operate button. This lamp flashes at the selected sequencing rate. The lamp operation capability requires some wiring modifications in the DAC itself and eliminates the TIME mode.
- The Remote Control Cables are qualified for use in the Apollo and Skylab vehicles.

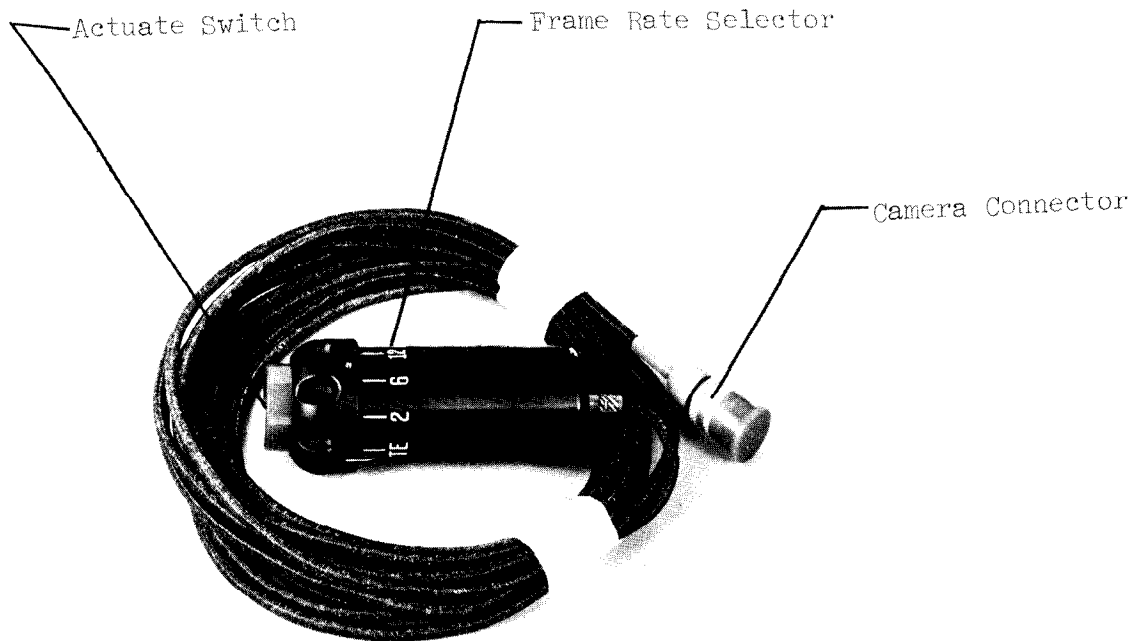

Figure 2.16-1 - Remote Control Cable (-305)

2.17 DAC Power Pack (SEB33100304):

The power pack is a self-contained, nickel cadmium battery power unit for the DAC system. It is used primarily during EVA photographic operations.

2.17.1 Significant Configurations:

<u>Configuration</u>	<u>Purpose</u>
-303	Apollo lunar surface unit; one mounting rail
-305	Skylab flight unit; two mounting rails

2.17.2 Characteristics:

- Manufactured by Technical Services Division, NASA MSC, Houston, Texas 77058.
- Weight (-303) - 4.2 lbs. (1908 g.).
(-305) - 4.3 lbs. (1954 g.).
Envelope (less cable)(-303) - 6.1 x 4.5 x 2.5 in. (15.5 x 11.4 x 6.4 cm.).
(-305) - 6.1 x 4.5 x 2.7 in. (15.5 x 11.4 x 6.9 cm.).
Volume (-303) - 68.6 in.³ (1122 cm.³).
(-305) - 74.1 in.³ (1213 cm.³).
- Power source is 24 rechargeable nickel cadmium batteries type 1.2 SCL per Gould-National Batteries, Inc., Alkaline Battery Division, St. Paul, Minnesota 55114. The batteries are potted and enclosed in a sealed stainless steel assembly. The nominal open circuit voltage is 32.0 VDC with 1.1 amp. hours capacity. The number of film magazines that can be powered by a DAC Power Pack varies with DAC sequencing rate and length of time from Power Pack charging as follows:

	<u>DAC Magazine (140)</u>			Shelf Life (Days)	<u>DAC Cassette (400)</u>		
	<u>15</u>	<u>30</u>	<u>60</u>		<u>15</u>	<u>30</u>	<u>60</u>
1 fps	1.5	1.2	1.1		0.5	0.4	0.3
2 fps	2.5	2	2		1.0	0.7	0.6
6 fps	7	6	5		2.0	2	1.7
12 fps	13	10	9		4.7	4	3.5
24 fps	22	18	16		9	8	7

- Incorporated cable connects to DAC power connector (forward-most). Cable connector is a Bendix JTC6A-8-6S bayonet type. The -303 pack connector incorporates a metal tab assembly to assist EVA gloved connection of cable to DAC. The total cable/connector length is 7.5 ± 0.5 in. (19.05 ± 1.3 cm.).
- The mounting rail of the -303 configuration attaches the pack to the DAC Handle (see 2.20). One mounting rail of the -305 configuration attaches to the DAC EVA Bracket (see 2.19) and the other to the Universal Mount (see 2.18).
- The Power Pack has been qualification tested for use in the Apollo and Skylab vehicles and during EVA operations.

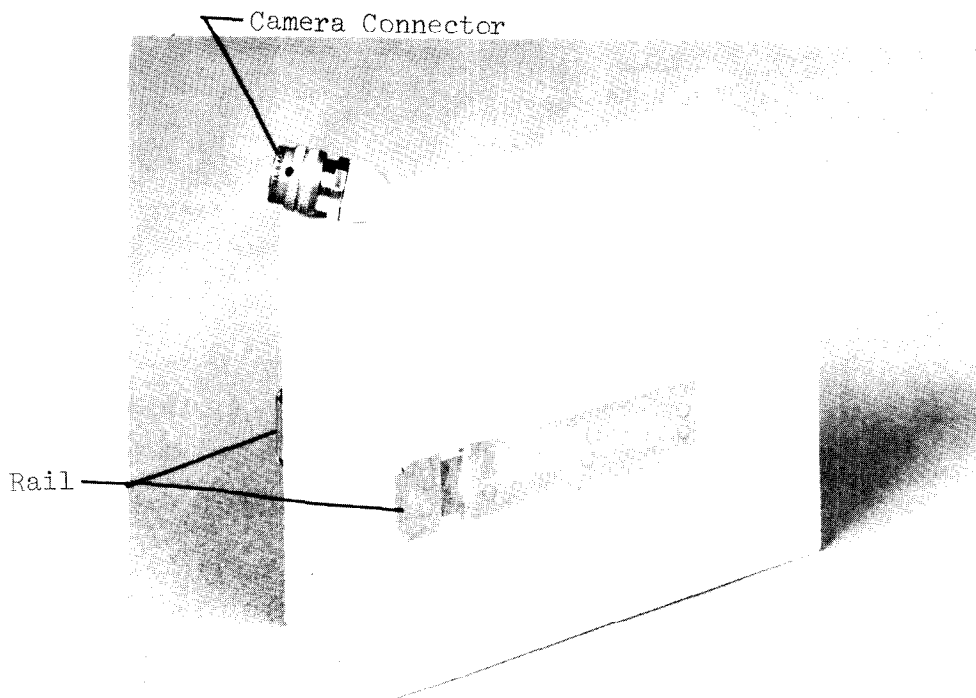

Figure 2.17-1 - DAC Power Pack (-305)

2.18 Universal Mount (SEC39106239):

As the name implies, the Universal Mount (UM) can be used to mount many different items in the Skylab SWS operations. For photographic operations, the UM can be used to mount the DAC, the High Intensity Light, and the 35 mm. Nikon camera (see 3.1).

2.18.1 Significant Configurations:

	<u>Configuration</u>	<u>Purpose</u>
	-301	Basic Skylab unit
B	-302	Skylab EVA unit - high trunion torque

2.18.2 Characteristics:

- Manufactured by Technical Services Division, NASA MSC, Houston, Texas 77058.
- Weight - 1.8 lbs. (817 g.).
Envelope - 11.65 x 4.35 x 4.70 in. (29.6 x 11.1 x 11.9 cm.).
Volume - 238 in.³ (3900 cm.³).
- UM base is attachable to the SWS floor grid and hand rails with single hand operation. The attachment can be locked securely.
- The mounting rail of the DAC, High Intensity Light, 35 mm. Nikon Camera (see 2.1), etc., slides into the rear of the UM shoe. The rail is automatically locked into the shoe upon full insertion. Depression of the lock button on the UM shoe releases the rail for item removal.
- The UM provides X, Y, and Z axis positioning of hardware item through 360° each axis with scale markings every 2°.
- The UM has been qualification tested for use in the Skylab vehicles and during EVA operations.

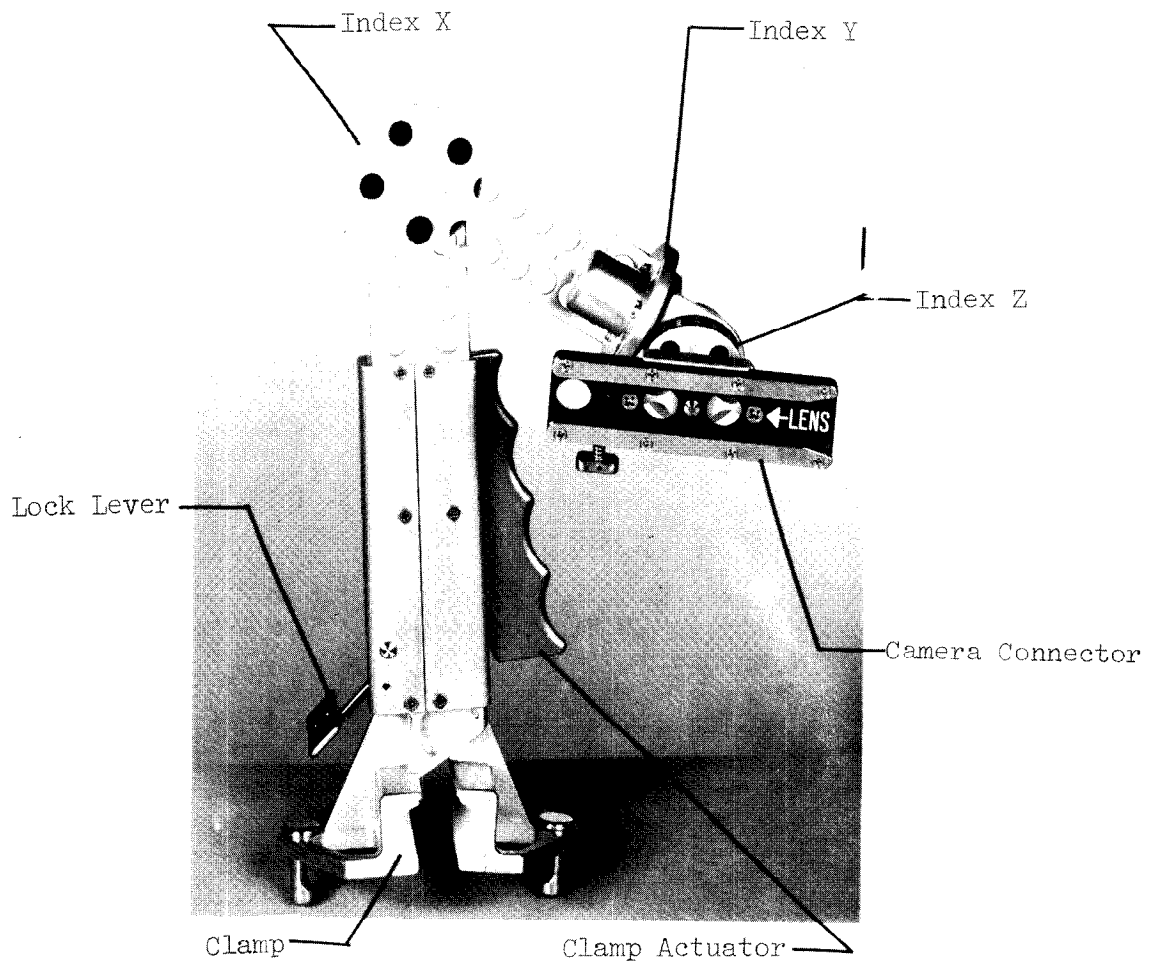

Figure 2.18-1 - Universal Mount

2.19 DAC EVA Bracket (SEC33100006):

This bracket provides the interconnection between the DAC and the DAC Power Pack for Skylab EVA operations.

2.19.1 Significant Configurations:

<u>Configuration</u>	<u>Purpose</u>
-301	Basic Skylab unit

2.19.2 Characteristics:

- Manufactured by J. A. Maurer, Inc., Long Island City, New York 11101.
- Weight - 0.4 lbs. (173 g.).
Envelope - 4.75 x 1.93 x 0.62 in. (12.1 x 4.9 x 1.6 cm.).
Volume - 5.7 in.³ (93 cm.³).
- The mounting rails of the DAC and the DAC Power Pack (see 2.17) slide into the rear of the EVA Bracket shoes. Automatic locking is provided upon full insertion of rails.
- The lock release lever on the bracket front is pressed toward the unit to be unlocked and removed.

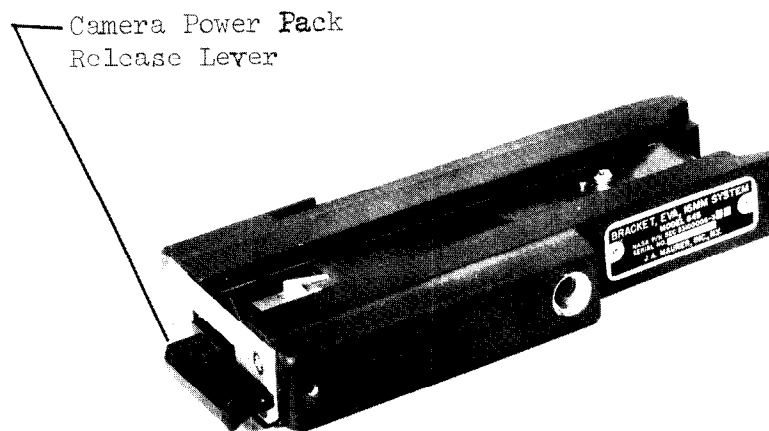

Figure 2.19-1 - DAC EVA Bracket

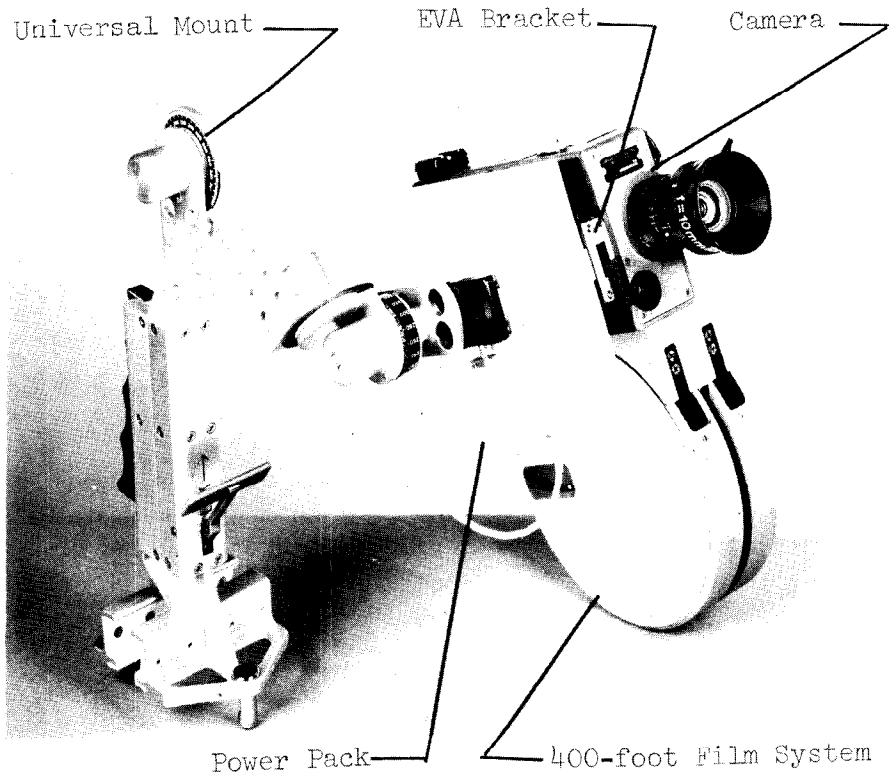

Figure 2.19-2 - Skylab DAC EVA Assembly

2.20 DAC Handle (SEB33100303):

The DAC Handle provides control of DAC operation and interconnects the DAC, the DAC Power Pack, the DAC RCU Bracket, and the LRV DAC Staff (SEB33100733).

2.20.1 Significant Configurations:

<u>Configuration</u>	<u>Purpose</u>
-301	Basic unit; no DAC Staff interface
-302	Apollo lunar surface unit; incorporates DAC Staff interface

2.20.2 Characteristics:

- Manufactured by J. A. Maurer, Inc., Long Island City, New York 11101.
- Weight (-301) - 1.1 lbs. (500 g.).
(-302) - 1.5 lbs. (682 g.).
Envelope (less cable) (-301) - 9.55 x 4.78 x 1.25 in. (24.3 x 12.2 x 3.2 cm.).
(-302) - 9.55 x 4.78 x 3.15 in. (24.3 x 12.2 x 8.0 cm.)
Volume (-301) - 57.1 in.³ (936 cm.³);
(-302) - 144.0 in.³ (2359 cm.³).
- Handle cable connects to the DAC accessory connector (rearmost). Cable connector is a Deutch UR46-8-7P bayonet type. The total cable/connector length is 9.0 ± 0.5 in. (22.9 ± 1.3 cm.).
- The mode selector at the handle base can be used for selecting any sequencing mode of the DAC. Handle mode selection controls camera operation only when handle trigger is used to start the camera. DAC automatic operation can be stopped by depressing and releasing either the handle trigger or the camera operate button.
- Mounting slides are provided for the attachment of the DAC, the DAC Power Pack (see 2.17), and the DAC RCU Bracket (see 2.21).
- The LRV DAC Staff interface incorporated on the -302 configuration can be rotated 120° for elevation pointing control and can be firmly locked in position by the operator.

- The DAC Handle has been qualification tested for use in the Apollo and Skylab vehicles and during EVA operations.

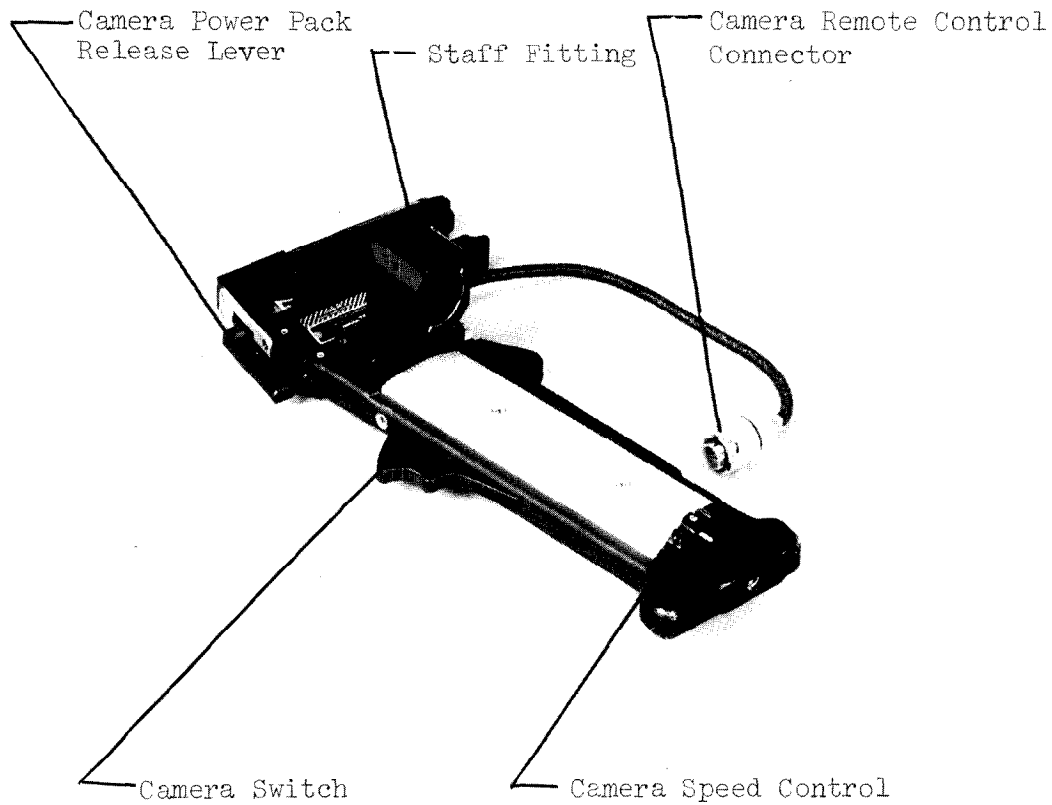

Figure 2.20-1 - DAC Handle

2.21 DAC RCU Bracket (SEB33100396):

This bracket provides for attachment of the DAC system to the remote control unit, RCU, on the astronaut's chest during lunar surface EVA operations.

2.21.1 Significant Configurations:

<u>Configuration</u>	<u>Purpose</u>
-301	Basic unit and Apollo lunar surface unit

2.21.2 Characteristics:

- Manufactured by J. A. Maurer, Inc., Long Island City, New York 11101.
- Weight - 0.3 lbs. (137 g.).
Envelope - 6.56 x 4.00 x 1.68 in (16.7 x 10.2 x 4.3 cm.).
Volume - 44.1 in.³ (723 cm.³).
- DAC RCU Bracket slides and locks into the top rear of the DAC Handle (see 2.20).
- A shoe slide on the rear of this bracket slides and locks onto the foot provided on the front of the RCU on the astronaut's chest.
- The locking levers are enlarged to facilitate gloved EVA operation.
- The DAC RCU Bracket has been qualification tested for use during EVA operations.

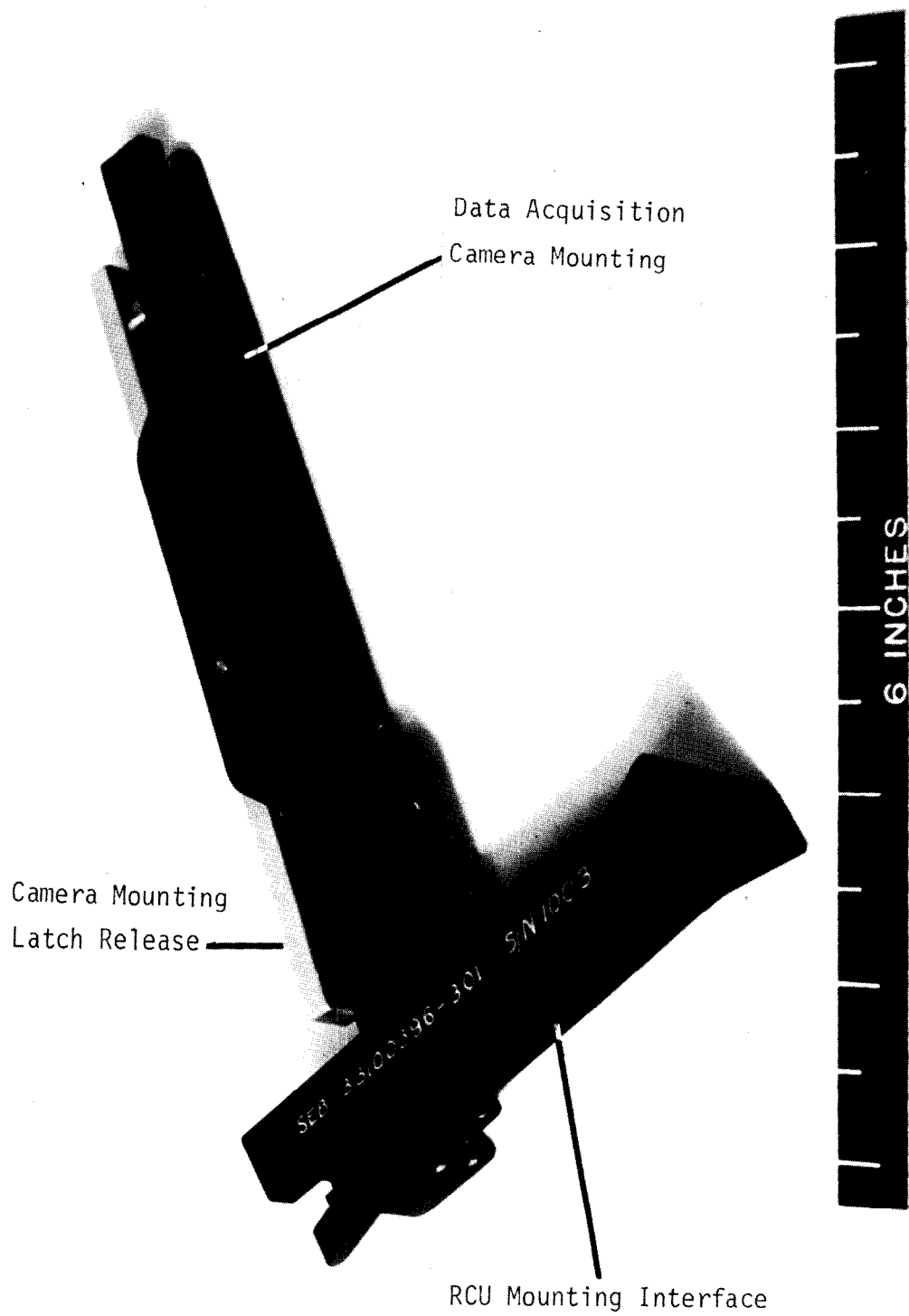

Figure 2.21-1 - DAC RCU Bracket

2.21-2

2.22 DAC Right Angle Adapter Bracket (SEB33100277):

This bracket connects the DAC to the LM Utility Light Clamp. When the Utility Light Clamp is attached to the LM Crash Bar for out-the-window photography of lunar surface operations, the DAC Right Angle Adapter Bracket provides the 90° rotation of the DAC required for properly oriented photography.

2.22.1 Significant Configurations:

<u>Configuration</u>	<u>Purpose</u>
-303	Apollo flight unit

2.22.2 Characteristics:

- Manufactured by Technical Services Division, NASA MSC, Houston, Texas 77058.
- Weight - 0.7 lbs. (318 g.).
Envelope - 4.0 x 2.5 x 1.63 in. (10.2 x 6.4 x 4.1 cm.).
Volume - 16.3 in.³ (267 cm.³).
- The mounting rail of the DAC slides into the rear of the bracket shoe. Automatic locking is provided upon full insertion of the DAC rail. A lock release button is provided on the bracket top.
- A thumb knob is provided on the bracket side for tightening the DAC/bracket interface to eliminate play.
- The short rail on the bracket bottom interfaces with the LM Utility Light Clamp or with any other shoe designed to accept the DAC mounting rail.
- This bracket has been qualified for use in the Apollo vehicles.

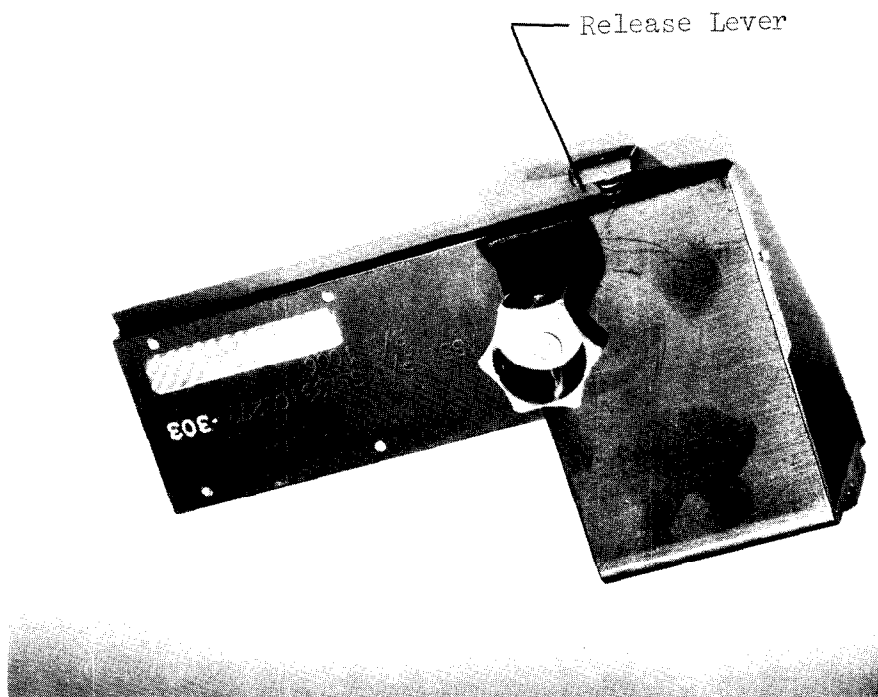

Figure 2.22-1 - DAC Right Angle Adapter Bracket

2.23 DAC Wedge Bracket (SEB33100564):

The DAC Wedge Bracket connects the DAC with the LM DAC Mount above the RH window to provide an increased photographic view of the lunar surface during powered descent and ascent.

2.23.1 Significant Configurations:

<u>Configuration</u>	<u>Purpose</u>
-301	Apollo flight unit

2.23.2 Characteristics:

- Manufactured by Technical Services Division, NASA MSC, Houston, Texas 77058.
- Weight - 0.7 lbs. (318 g.).
Envelope - 5.4 x 3.0 x 4.2 in. (13.7 x 7.6 x 10.7 cm.).
Volume - 68.0 in.³ (1,114 cm.³).
- The Wedge Bracket slides into the LM DAC window mount the same as the DAC. The DAC slides into the shoe of the Wedge Bracket and is locked with the slide lock provided on the bracket.
- The LM Window mount with and without the DAC Wedge Bracket provides the following camera pointing angles in IM coordinates:

	<u>Pitch</u>	<u>Yaw</u>
Without wedge	59° Down	8° Right
With wedge	42° Down	3° Right

- The Wedge Bracket is qualified for use in the Apollo vehicles.

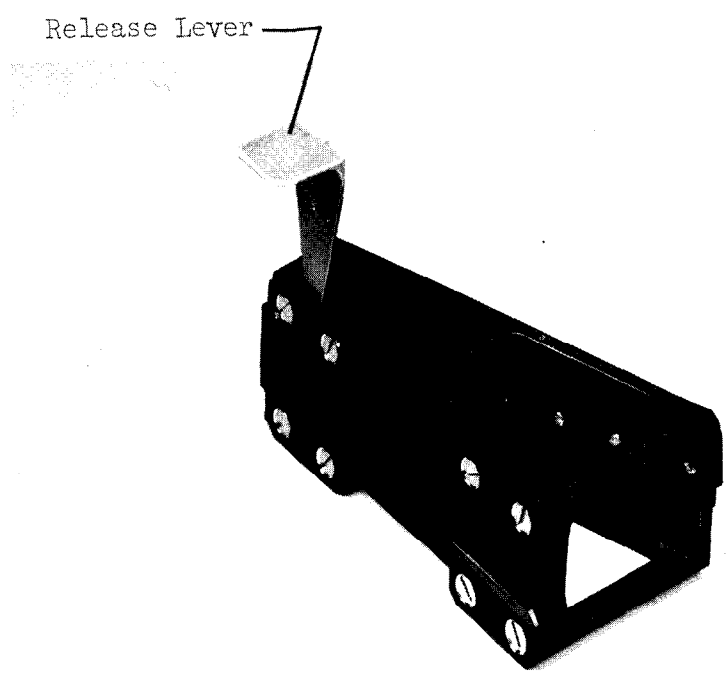
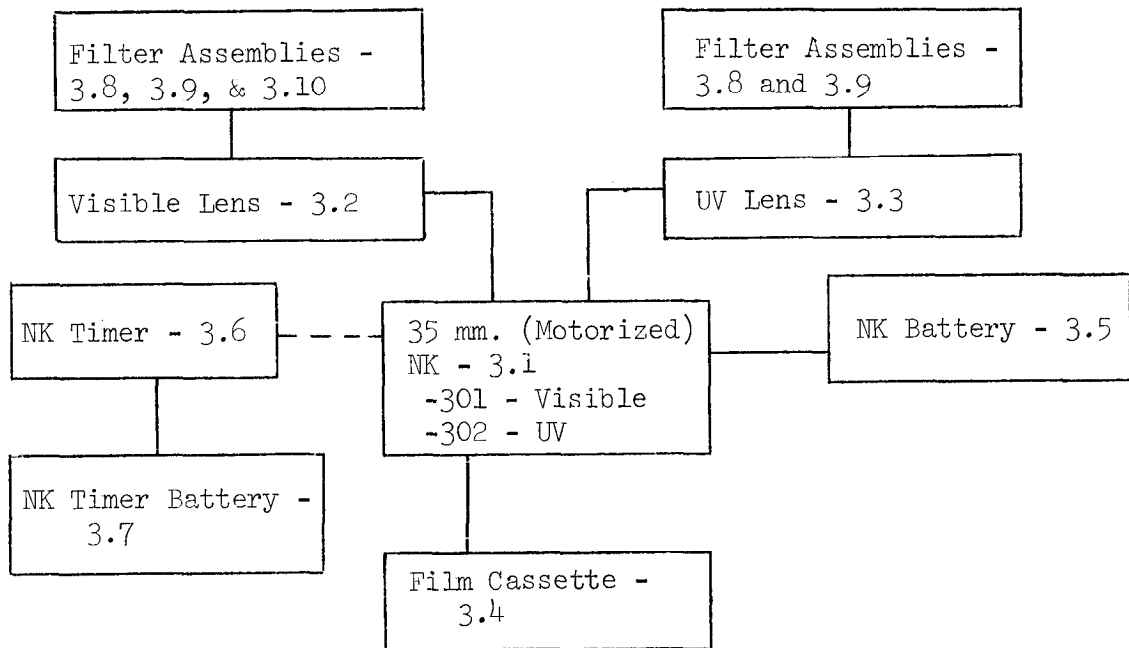

Figure 2.23-1 - DAC Wedge Bracket

3.0

35 mm. Still Camera System



SKYLAB

APOLLO

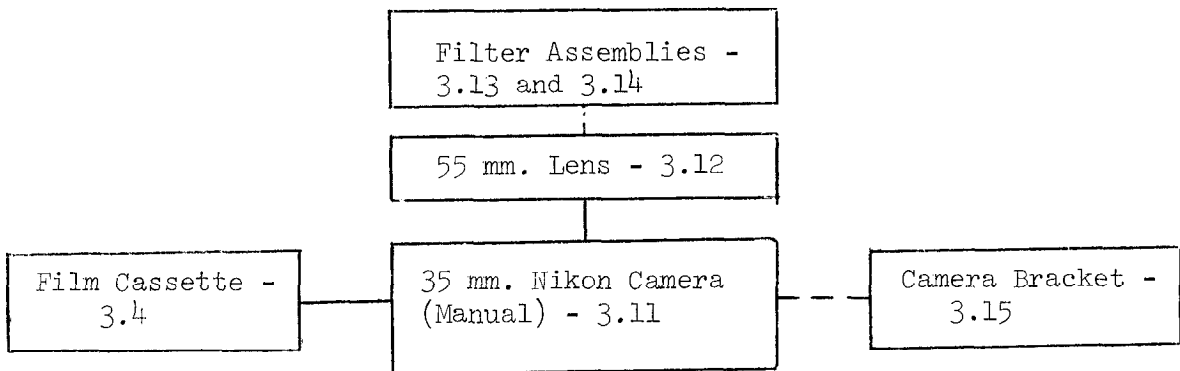

3.1 35 mm. Nikon Camera (NK) (Motorized) (SEB33100772):

The motorized 35 mm. Nikon camera, a modification of commercial Nikon equipment, is the heart of the S063 Experiment camera system for Skylab. This camera body incorporates reflex viewing and thru-the-lens coupled light metering along with motorized film advancement. For the experiment operations, a visible lens (see 3.2) and an ultraviolet lens (see 3.3) are used on this body.

3.1.1 Significant Configurations:

<u>Configuration</u>	<u>Purpose</u>
-301	Skylab Experiment S063 visible camera body; meter-reflex viewfinder included; used with 55 mm., f/1.2 Lens (see 3.2).
-302	Skylab Experiment S063 UV camera body; no reflex viewing or light metering as configured; used with 55 mm., f/2 UV Lens (see 3.3).

3.1.2 Characteristics:

- Manufactured by Nippon Kogaku K.K., Tokyo, Japan, and distributed by Ehrenreich Photo-Optical Industries, Inc., Garden City, N. Y. 11530.
- Weight (w/o film or lens) (-301) - 3.66 lbs. (1,660 g.)
(-302) - 3.10 lbs. (1,410 g.)
- Envelope (-301) - 6.55 x 6.16 x 2.80 in. (16.6 x 15.7 x 7.1 cm.)
(-302) - 6.55 x 5.91 x 2.80 in. (16.6 x 15.0 x 7.1 cm.)
- Volume (-301) - 112.9 in.³ (1850 cm.³)
(-302) - 108.3 in.³ (1776 cm.³)
- The included focal plane shutter has the following settings: T (Time), 1, 1/2, 1/4, 1/8, 1/15, 1/30, 1/60, 1/125, 1/250, 1/500, and 1/1000 second. A standard connector for X-synchronization with the shutter at 1/60 sec. or lower shutter speeds is provided.
- Accepts lenses with the commercial Nikon mounting. The 55 mm., f/1.2 visible lens (see 3.2) and the 55 mm., f/2 UV lens (see 3.3) are intended for use on this camera body (see 3.1.1).
- The visible camera (-301) viewfinder shows the full thru-the-lens coverage, shutter speed setting, and the light meter needle and matching indicator. The viewfinder can be removed easily to permit waist-level camera operation or replacement

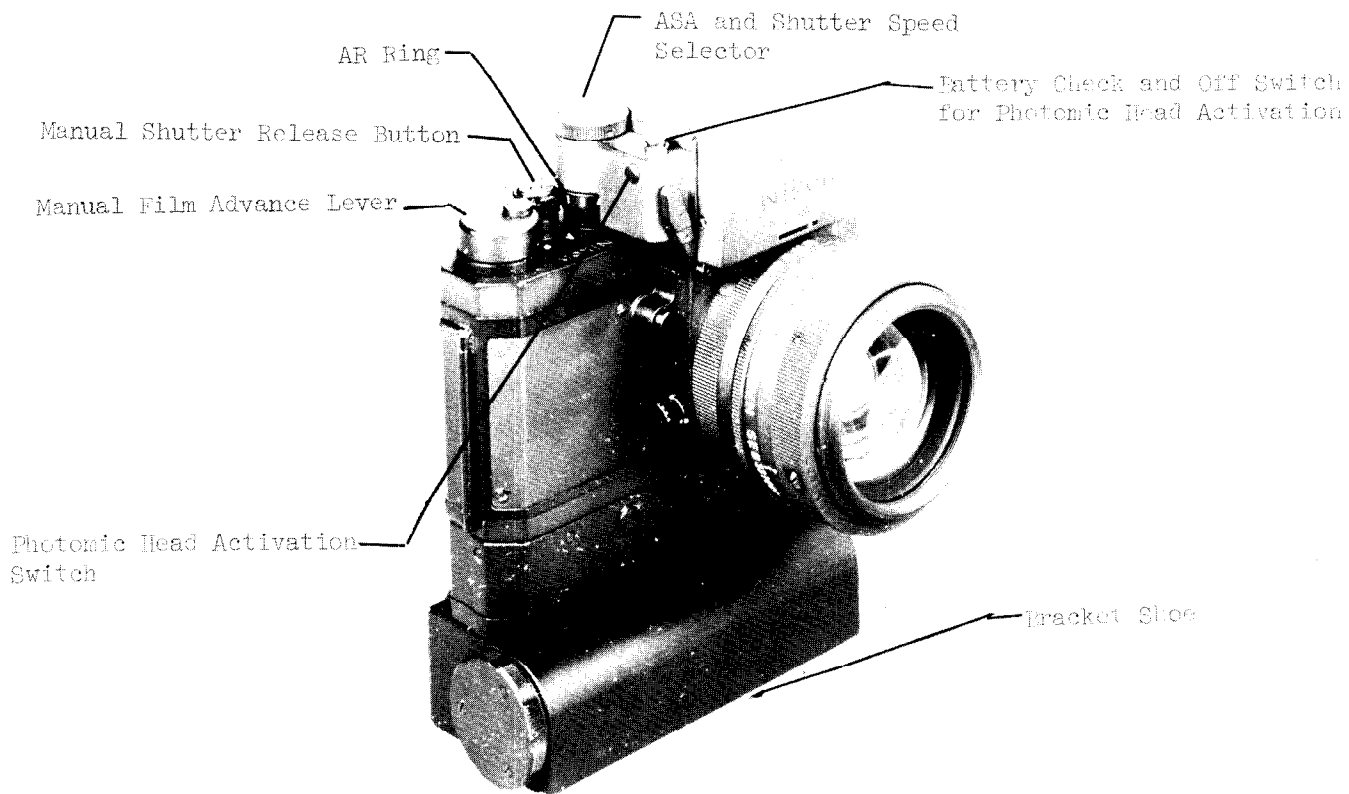

Figure 3.1-1 - 35 mm. Nikon Visible Camera (-301) and Lens

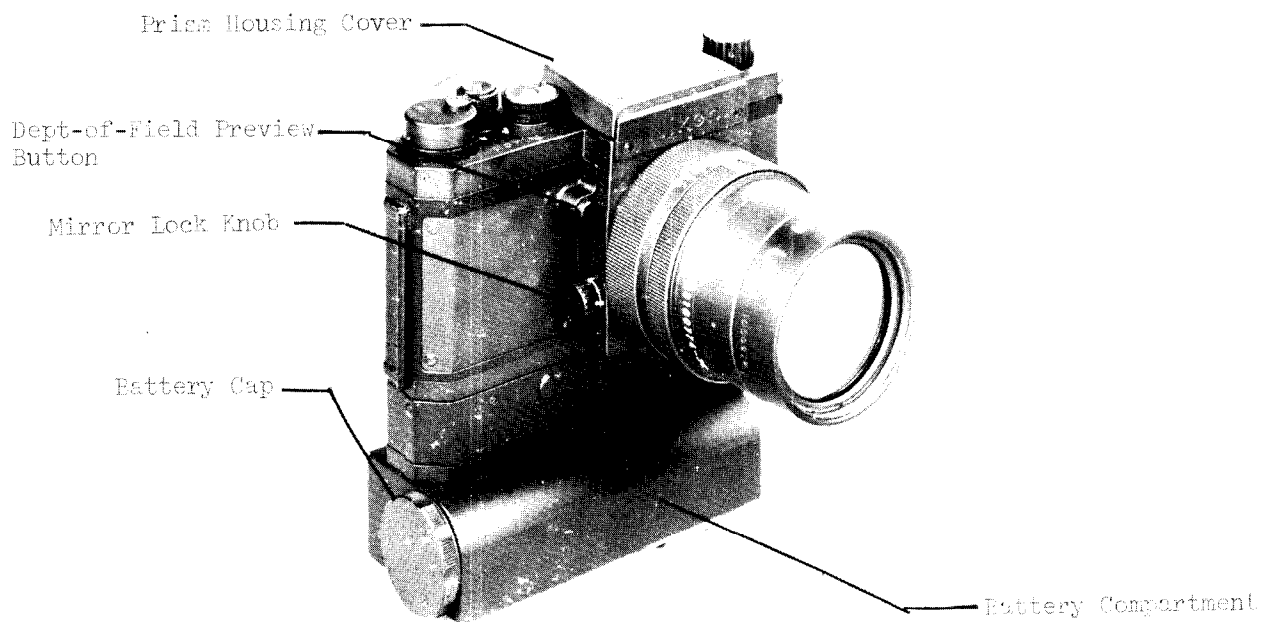

Figure 3.1-2 - 35 mm. Nikon UV Camera (-302) and Lens

of the focusing screen. The UV camera (-302) has no meter-viewfinder; instead, a metal cover is installed over the camera focusing screen. This cover can be removed easily for installation of the meter-viewfinder of the visible camera.

- The thru-the-lens, match-needle, light measuring system (-301 camera) incorporated in the viewfinder is settable for film speeds of ASA 6 thru 6400 and is coupled to the aperture ring of the lens.
- Film, contained in the special Film Cassette (see 3.4), is installed and threaded in the camera by the operator. The film must be rewound into its cassette before removal from the camera.
- The camera frame counter (top) indexes with each film advancement to a maximum of 72. The motor frame counter (back) indexes to zero from a maximum of 72 manually set depending on the film type and quantity. The even frame numbers are visible through the counter windows.
- The motor drive is operated in single (S) or continuous (C) modes by depressing the motor operate button on the rear of the motor module. The continuous mode is restricted to shutter speeds of 1/250 sec. and faster and provides 3 exposures per second. Timer (T) mode operation locks the motor operate button and permits motorized NK operation by the NK Timer (see 3.6) only. Manual film advancement and shutter release with the top operate button is possible regardless of motor drive configuration.
- The motor drive is powered by a self-contained, replaceable Ni-Cd battery (see 3.5) with a capacity sufficient for 2500 camera cycles. The electrical circuit is protected with a replaceable 1.0 amp. fuse. A 1.0 amp. fuse and a slug are provided as spares.
- A connector is provided for interconnection of the NK Timer (see 3.6). The NK connector is a Deutsch bayonet type UR40-8-7S. The plugs of the DAC Remote Control Cable (see 2.16) and the Hasselblad Intervalometer (see 4.14) can be installed on the NK connector with no functional effect.
- The camera incorporates controls for locking the mirror up and for previewing the depth-of-field.
- Includes a mounting foot compatible with the Experiment S063 camera station mounts and with the Universal Mount (see 2.20). A 1/4 x 20 threaded receptacle for mounting is provided also.

- The motorized Nikon camera has been qualified for use in the Skylab vehicles.

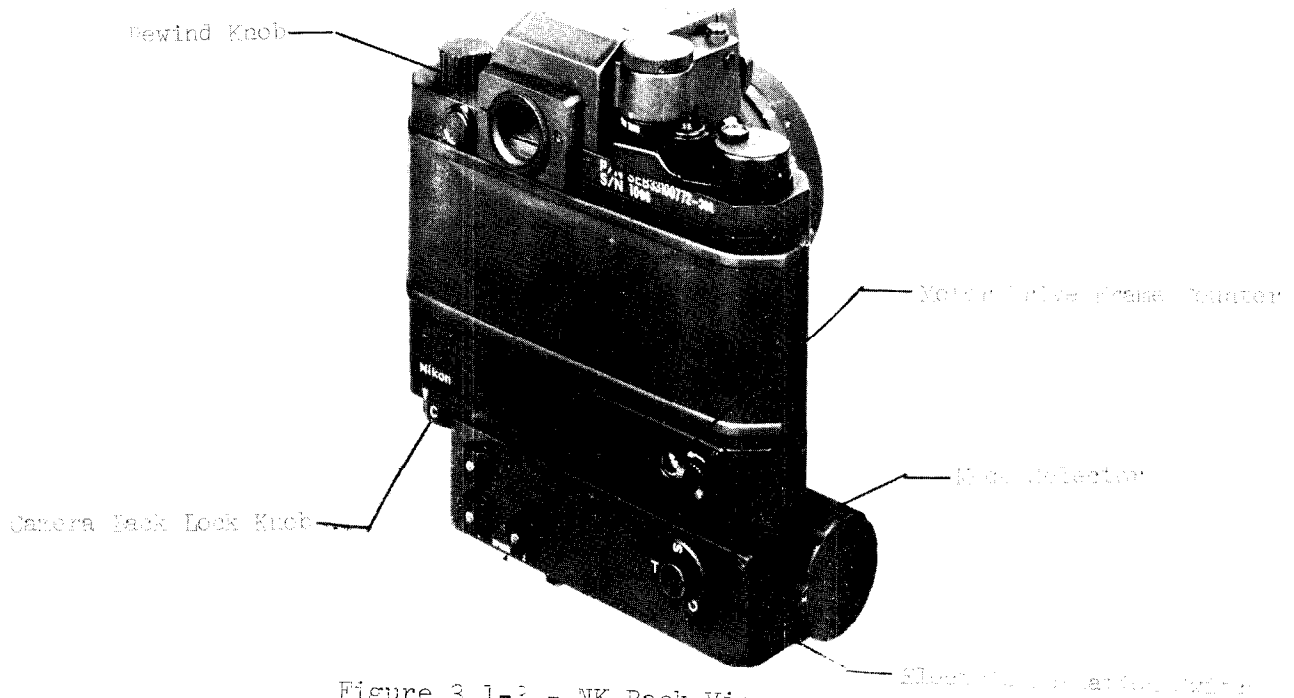

Figure 3.1-3 - NK Back View

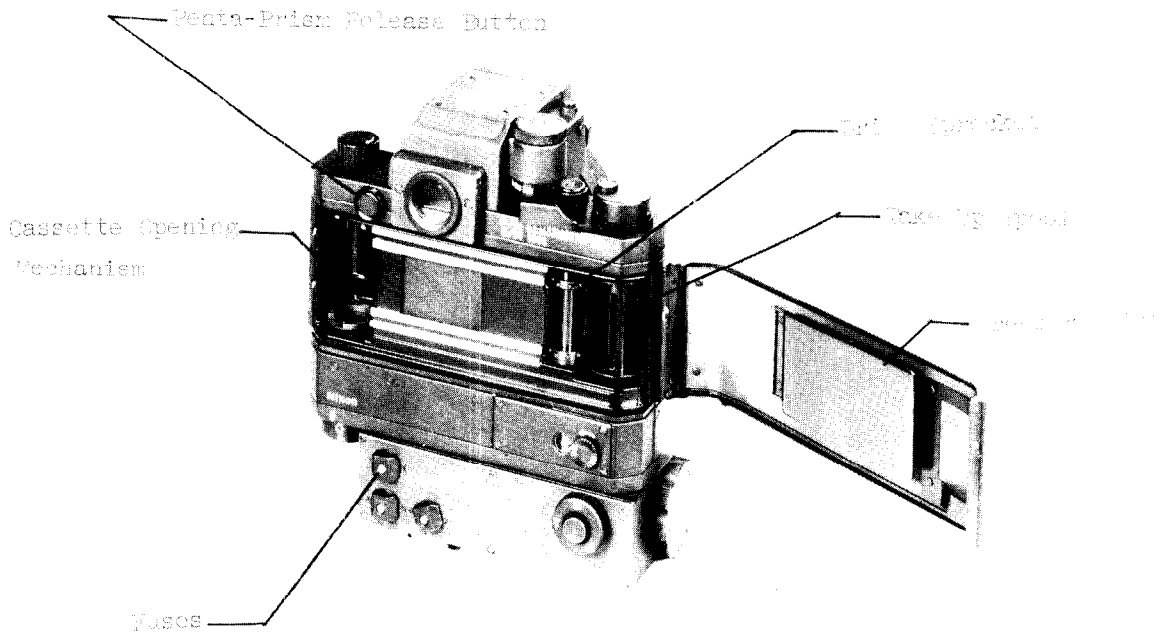

Figure 3.1-4 - NK With Back Open

3.2 55 mm. Visible Lens (SEB33100773):

This standard focal length lens is used on the -301 motorized NK (see 3.1) to obtain photographs in the visible wavelengths of light for Skylab Experiment S063. The mechanical and optical characteristics of this lens are the same as for the 55 mm. Lens, P/N SEB3310009, (see 3.11).

3.2.1 Significant Configurations:

<u>Configuration</u>	<u>Purpose</u>
-301	Skylab Experiment S063 visible lens; used on -301 NK (see 3.1).

3.2.2 Characteristics:

- Manufactured by Nippon Kogaku K.K., Tokyo, Japan, and distributed by Ehrenreich Photo-Optical Industries, Inc., Garden City, N. Y. 11530.
- Weight - 1.0 lbs. (454 g.)
Envelope - 2.36 x 2.89 Dia. in. (6.0 x 7.4 Dia. cm.)
Volume - 15.6 in.³ (255 cm.³)
- Field-of-view - 24° x 36°, 43° diagonal
- Focus range - 2 feet to infinity with markings at infinity and 2, 2.5, 3, 3.5, 4, 5, 7, 10, 15, and 30 feet.
- Aperture - f/1.2 through f/16 with detents at each full stop value.
- Incorporates an interconnecting tab for coupling the lens aperture ring with the camera light meter system.
- Accepts 52 mm. (0.75 mm. pitch) screw-in or 54 mm. OD slip-on filters. The Skylab filters (see 3.8, 3.9, and 3.10) are used on this lens during experiment operations. The Apollo filters (see 3.13 and 3.14) can be attached to this lens also.
- The outer surface of the lens barrel front is engraved in white with, "f=55 mm."
- This lens has been qualified for use in the Skylab vehicles.

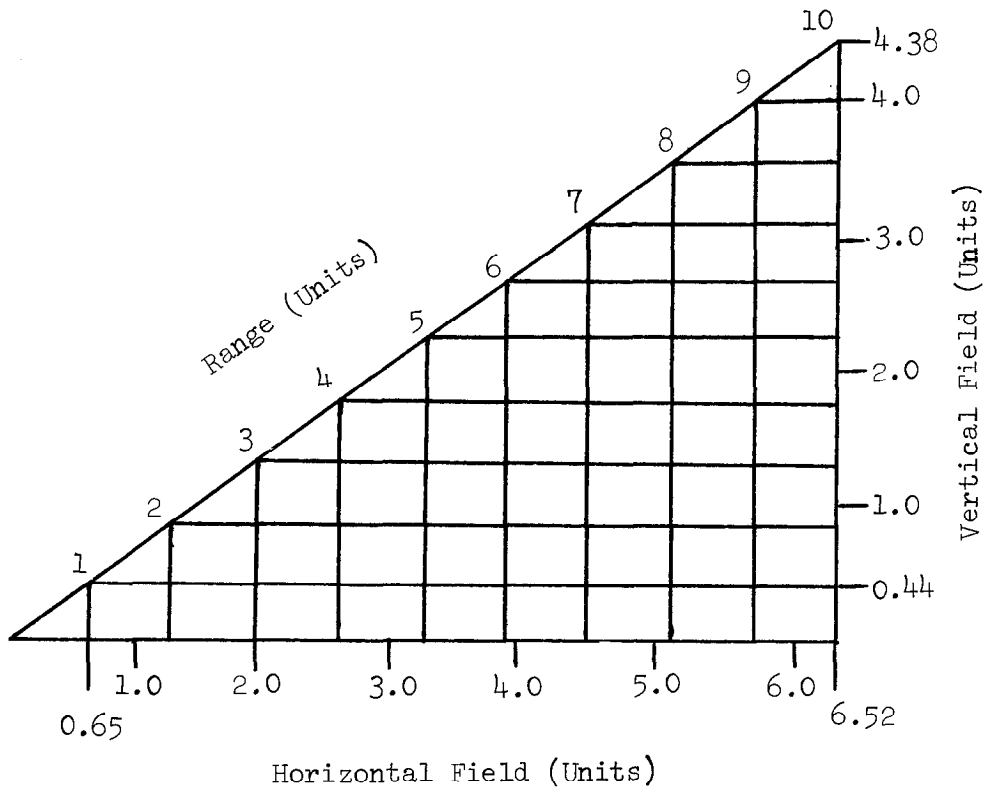
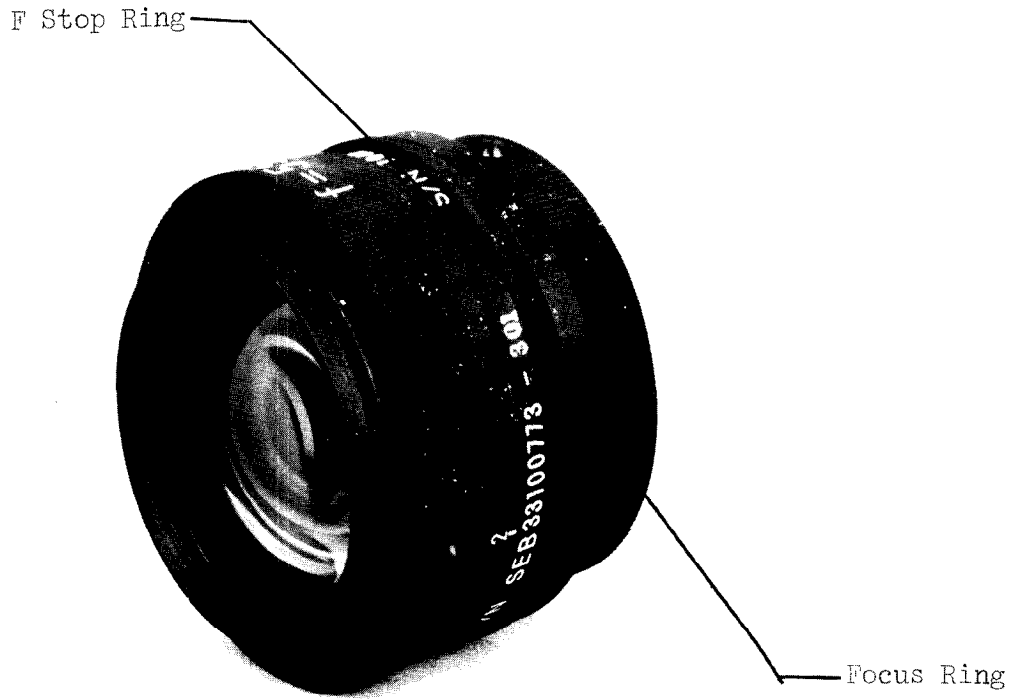

Figure 3.2-1 - 55 mm. Visible Lens and Field-of-view Chart

3.3 55 mm. UV Lens (SEB33100774):

The 55 mm., f/2 UV Lens is specially designed to permit photography in the ultraviolet wavelengths of 200 to 400 nm. This lens is used on the -302 motorized NK (see 3.1) for the UV portion of Skylab Experiment S063.

3.3.1 Significant Configurations:

<u>Configuration</u>	<u>Purpose</u>
-301	Skylab Exp. S063 UV lens; used on -302 NK (see 3.1).

3.3.2 Characteristics:

- Manufactured by Nippon Kogaku K.K., Tokyo, Japan, and distributed by Ehrenreich Photo-Optical Industries, Inc., Garden City, N. Y. 11530.
- Weight - 0.87 lbs. (395 g.)
Envelope - 3.37 x 2.54 Dia. in. (8.6 x 6.5 Dia. cm.)
Volume - 17.1 in.³ (279 cm.³)
- Field-of-view - 24° x 36°; 43° diagonal
- Focus is fixed for infinity objects.
- Aperture - f/2 through f/16 with detents at each full stop value.
- The lens aperture ring cannot be coupled with the camera light meter system.
- Accepts 52 mm. (0.75 pitch) screw-in or 54 mm. OD slip-on filters. The Skylab filters (see 3.8 and 3.9) are used on this lens during experiment operations.
- The outer surface of the lens barrel front is engraved in white with, "f=55 mm. UV."
- This lens is qualified for use in the Skylab vehicles.



Figure 3.3-1 - 55 mm. UV Lens

Transmittance

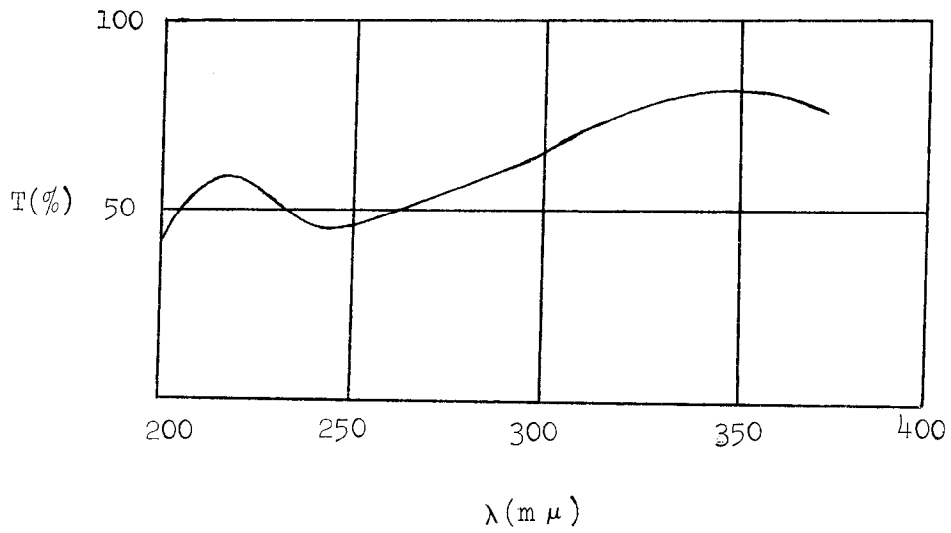

Figure 3.3-2 - UV Lens Spectral Transmission

3.4 Film Cassette Assembly (SEB33100775):

The Film Cassette Assembly includes the 35 mm. film cassette containing the film and the film can which provides protection for the cassette during storage and handling.

3.4.1 Significant Configurations:

<u>Configuration</u>	<u>Purpose</u>
-301	Apollo and Skylab assembly including film cassette and can.
-001	Can
-002	Film cassette

3.4.2 Characteristics:

- Manufactured by Nippon Kogaku K.K., Tokyo, Japan, and distributed by Ehrenreich Photo-Optical Industries, Inc., Garden City, N. Y. 11530.
- Weight - 0.20 lbs. (91.0 g.)
Envelope - 2.10 x 1.44 Dia. in. (5.3 x 3.7 Dia. cm.)
Volume - 3.42 in.³ (56.0 cm.³)
- The useful film capacity of the cassette varies with film type and with the amount of preflight sensitometry. With standard base films (4 mil, 102 μ m), approximately 50 frames are available; with thin base films (2.5 mil, 64 μ m), approximately 70 frames are available.
- The cassette must be loaded and unloaded in a photographic darkroom. The film must be rewound into the cassette before the camera back is opened for cassette removal.
- The can is vented and includes a screw top and a patch of Velcro on the bottom.
- The 35 mm. film cassette assembly has been qualified for use in the Apollo and Skylab vehicles.

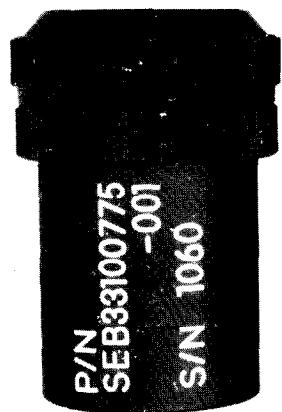

Cassette Container

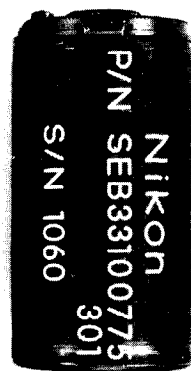

Film Cassette

Figure 3.4-1 - Film Cassette Assembly

3.5 NK Battery Assembly (SEB33100777):

The NK Battery Assembly is the power source for the 35 mm. motorized Nikon Camera (see 3.1). This battery can be replaced easily by the camera operator.

3.5.1 Significant Configurations:

<u>Configuration</u>	<u>Purpose</u>
-301	Skylab unit

3.5.2 Characteristics:

- Manufactured by Union Carbide Corp., New York, N. Y. 10017.
- Weight - 0.30 lbs. (136 g.)
Envelope - 3.50 x 1.04 Dia. in. (7.8 x 2.7 Dia. cm.)
Volume - 3.0 in.³ (49 cm.³)
- The power source is 10 rechargeable nickel cadmium cells type BH 225 per Union Carbide Corp. The cells are stacked, spotwelded together and encased in FEP Teflon tubing. The nominal open circuit voltage is 12.5 VDC with sufficient capacity for 2500 camera cycles.
- The shape of the battery prohibits incorrect installation and connection in the NK. The positive (+) end of the battery must be inserted into the NK for proper installation.
- The NK Battery has been qualified for use in the Skylab vehicles.

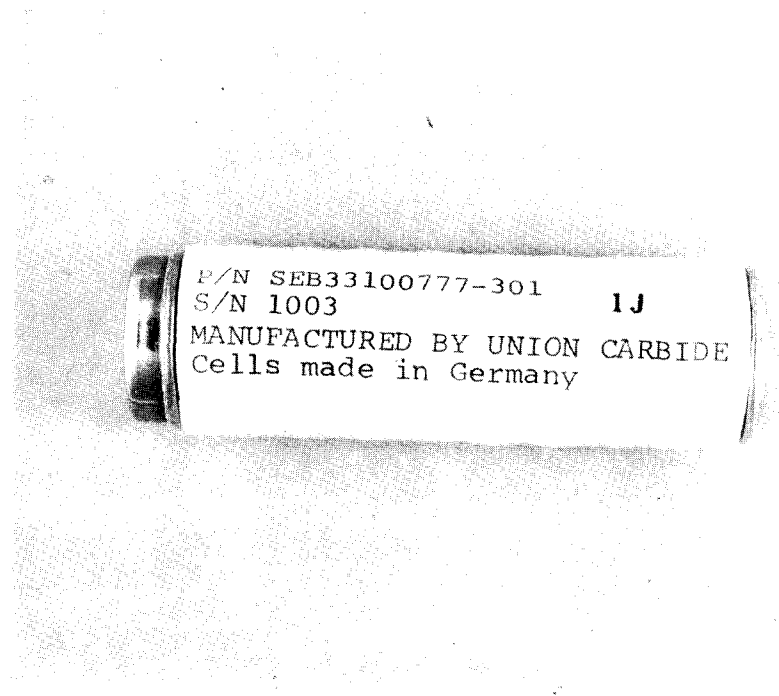

Figure 3.5-1 - NK Battery Assembly

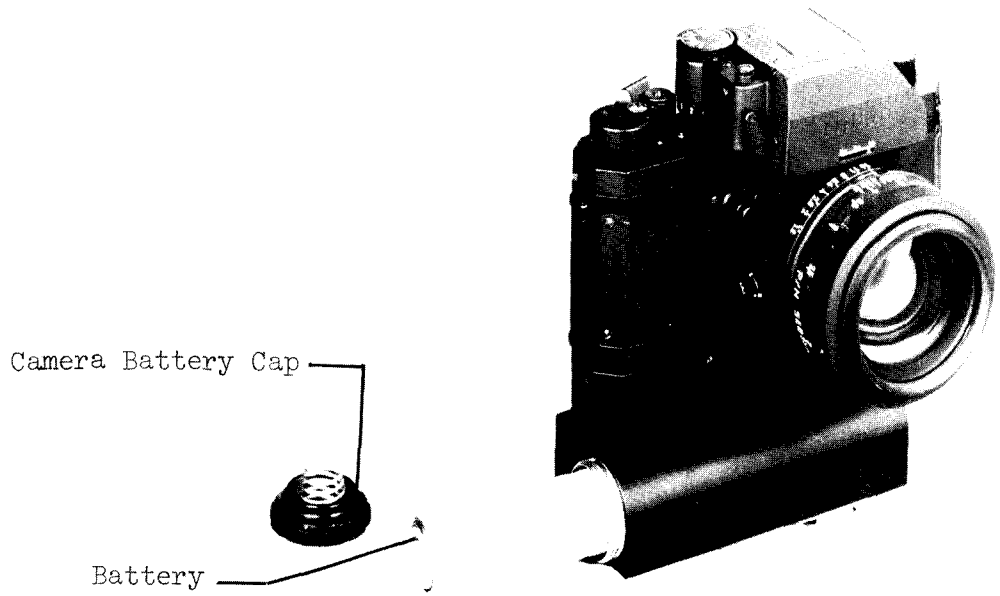

Figure 3.5-2 - Battery Installation in NK

3.6 NK Timer (SEB33100776):

The NK Timer can be connected to the motorized Nikon camera (see 3.1) to provide automatic control of time exposures. The timer has solid state circuitry and is powered by a replaceable battery (see 3.7).

3.6.1 Significant Configurations:

<u>Configuration</u>	<u>Purpose</u>
-301	Skylab flight unit

3.6.2 Characteristics:

- Manufactured by Nippon Kogaku K.K., Tokyo, Japan, and distributed by Ehrenreich Photo-Optical Industries, Inc., Garden City, New York 11530.
- Weight - 0.77 lbs. (350 g.)
Envelope (w/o cable) - 3.54 x 3.01 x 1.68 in. (9.0 x 7.7 x 4.3 cm.)
Volume (w/o cable) - 17.9 in.³ (294 cm.³)
- The NK Timer can control the NK for time exposures of 1, 2, 4, 8, 16, 32, and 64 second duration. The exposure accuracy is $\pm 10\%$ with $\pm 2\%$ repeatability throughout the temperature range of -20°C to $+4^{\circ}\text{C}$. An OFF position is provided also.
- The NK Timer connects to the NK with a 16 ± 2 in. (40.6 ± 5.1 cm.) cable. The NK end of the cable has a Deutsch type UR46-8-7P bayonet connector.
- The timer is powered by a replaceable battery (see 3.7). The battery provides for more than 25 hours of timer operation.
- The timer incorporates a mounting foot compatible with the shoe provided at the Experiment S063 UV camera station and with the Universal Mount (see 2.18).
- The NK Timer has been qualified for use in the Skylab vehicles.

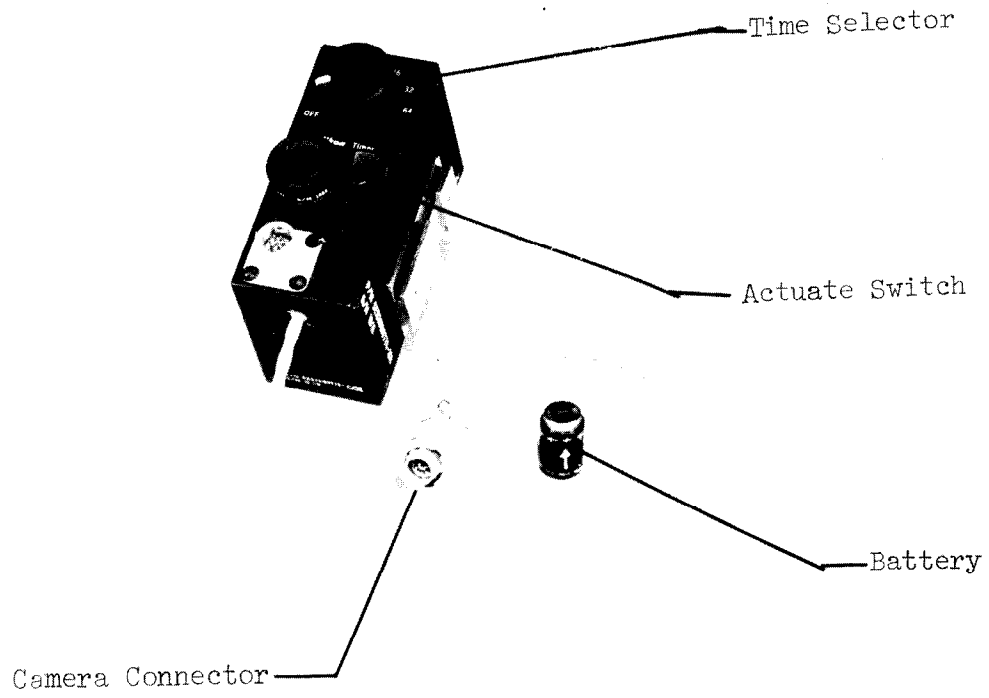

Figure 3.6-1 - NK Timer

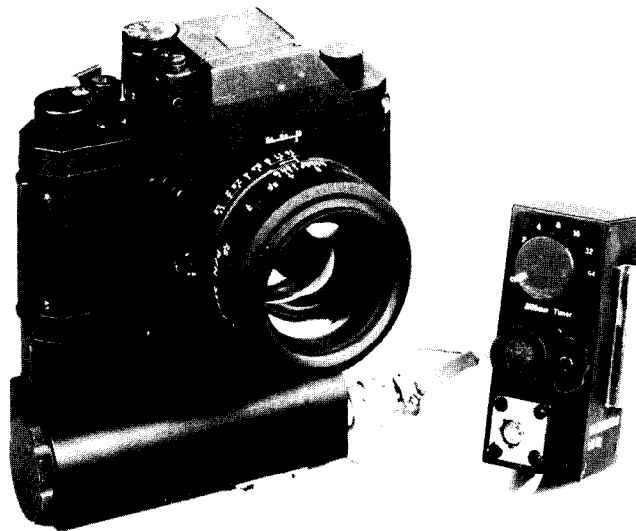

Figure 3.6-2 - Connection of Timer to NK

3.7 NK Timer Battery (SEC33100796):

The NK Timer Battery is the power source for the NK Timer (see 3.6). This battery can be replaced easily by the timer operator.

3.7.1 Significant Configurations:

<u>Configuration</u>	<u>Purpose</u>
-301	Skylab unit

3.7.2 Characteristics:

- Manufactured by Union Carbide Corp., New York, N. Y. 10017.
- Weight - 0.02 lbs. (10 g.)
Envelope - 0.87 x 0.54 Dia. in. (2.2 x 1.4 Dia. cm.)
Volume - 1.85 in.³ (30.3 cm.³)
- The power source is 4 laminated oxidized silver cells type S-76E per Union Carbide Corp. The cells are stacked, spot-welded together and potted. The nominal open circuit voltage is 6 VDC with sufficient capacity for more than 25 hours of timer operation.
- The shape of the battery prohibits incorrect installation and connection in the timer. The positive (+) end of the battery must be inserted into the NK Timer for proper installation.
- The NK Timer Battery has been qualified for use in the Skylab vehicles.



Figure 3.7-1 - NK Timer Battery

3.8 Twin Filter Slide Assembly (SEC33100789):

The Twin Filter Slide Assembly is used on the NK during Skylab Experiment S063 operations when two filters are required in rapid alternation. One assembly is designated for the visible photography and one for the UV.

3.8.1 Significant Configurations:

<u>Configuration</u>	<u>Purpose</u>
-301	Skylab Exp. S063 unit; UV camera filters; marked "UV."
-302	Skylab Exp. S063 unit; Visible camera filters; marked "Visible."

3.8.2 Characteristics:

- Assembly is manufactured by Nippon Kogaku K.K., Tokyo, Japan, and distributed by Ehrenreich Photo-Optical Industries, Inc., Garden City, N. Y. 11530.
- Weight - 0.70 lbs. (318 g.)
Envelope - 7.33 x 4.85 x 0.95 in. (18.6 x 12.3 x 2.4 cm.)
Volume - 33.8 in.³ (553 cm.³)
- Each Twin Filter Slide Assy. contains two filters that alternately can be placed in front of the camera lens by the operator. The specific filter types are selected and provided by the Exp. S063 principal investigator.
- The assembly is screwed onto the front of its lens (see 3.2 and 3.3) by the camera operator. Once attached to the lens, the assembly can be rotated 360° and locked at the best position for access to the filter selection controls.
- Each filter has a position control tab. A detent is provided to locate the tab (filter) in the stow or in the on position.
- The Twin Filter Slide Assembly is qualified for use in the Skylab vehicles.

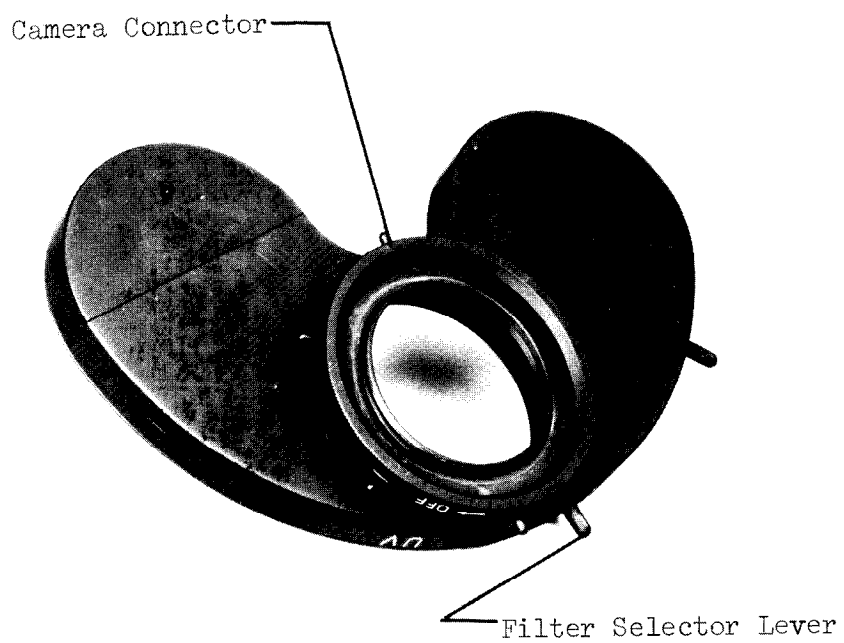

Figure 3.8-1 - Twin Filter Slide Assembly

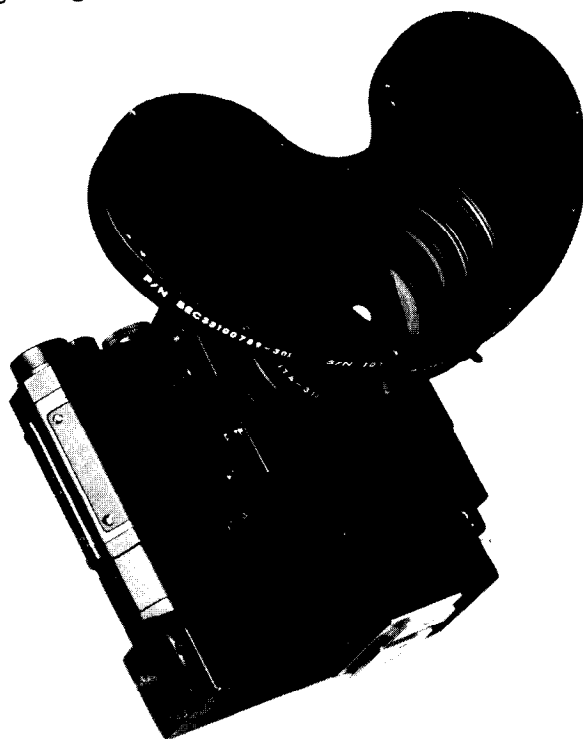

Figure 3.8-2 - Twin Filter Assembly Installed on NK

3.9 Single Filter Assembly (SEC33100790):

The Single Filter Assembly is used on the NK during Skylab Experiment S063 operations when only one filter is required for the experiment run. One assembly is designated for the visible photography and one for the UV.

3.9.1 Significant Configurations:

<u>Configuration</u>	<u>Purpose</u>
-301	Skylab Exp. S063 unit; UV camera filter; marked "UV."
-302	Skylab Exp. S063 unit; visible camera filter; marked "Visible."

3.9.2 Characteristics:

- Assembly is manufactured by Nippon Kogaku K.K., Tokyo, Japan, and distributed by Ehrenreich Photo-Optical Industries, Inc., Garden City, N. Y. 11530.
- Weight - 0.20 lbs. (90 g.)
Envelope - 0.69 x 2.68 Dia. in. (1.75 x 6.81 Dia. cm.)
Volume - 3.9 in.³ (64 cm.³)
- The specific filter types are selected and provided by the Exp. S063 principal investigator.
- The filter assembly is screwed onto the front of its lens (see 3.2 and 3.3) by the camera operator.
- The Single Filter Assembly is qualified for use in the Skylab vehicles.

F

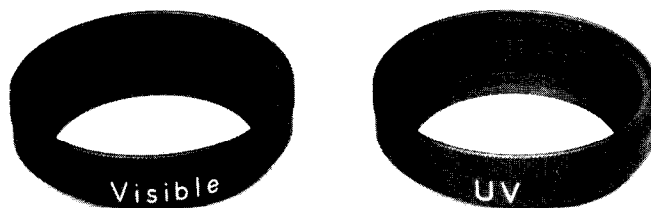

Figure 3.9-1 - Single Filter Assemblies

3.10 35 mm. Filter Assembly (Haze)(SFB33100791):

This filter assembly is used on the Visible NK during Skylab Experiment S063 operations. The filter is a standard haze cutting filter.

3.10.1 Significant Configurations:

<u>Configuration</u>	<u>Purpose</u>
-301	Skylab Exp. S063 unit; visible camera filter; marked "Visible Haze."

3.10.2 Characteristics:

- Manufactured by Nippon Kogaku K.K., Tokyo, Japan, and distributed by Ehrenreich Photo-Optical Industries, Inc., Garden City, N. Y. 11530.
- Weight - 0.20 lbs. (90 g.)
Envelope - 0.69 x 2.68 Dia. in. (1.75 x 6.81 Dia. cm.)
Volume - 3.9 in.³ (64 cm.³)
- The filter is the Nikon Skylight, #LLA, requiring no exposure correction.
- This filter assembly is screwed onto the front of the visible lens (see 3.2) by the camera operator.
- The 35 mm. Filter Assembly (Haze) is qualified for use in the Skylab vehicles.



Figure 3.10-1 - Haze Filter Assembly

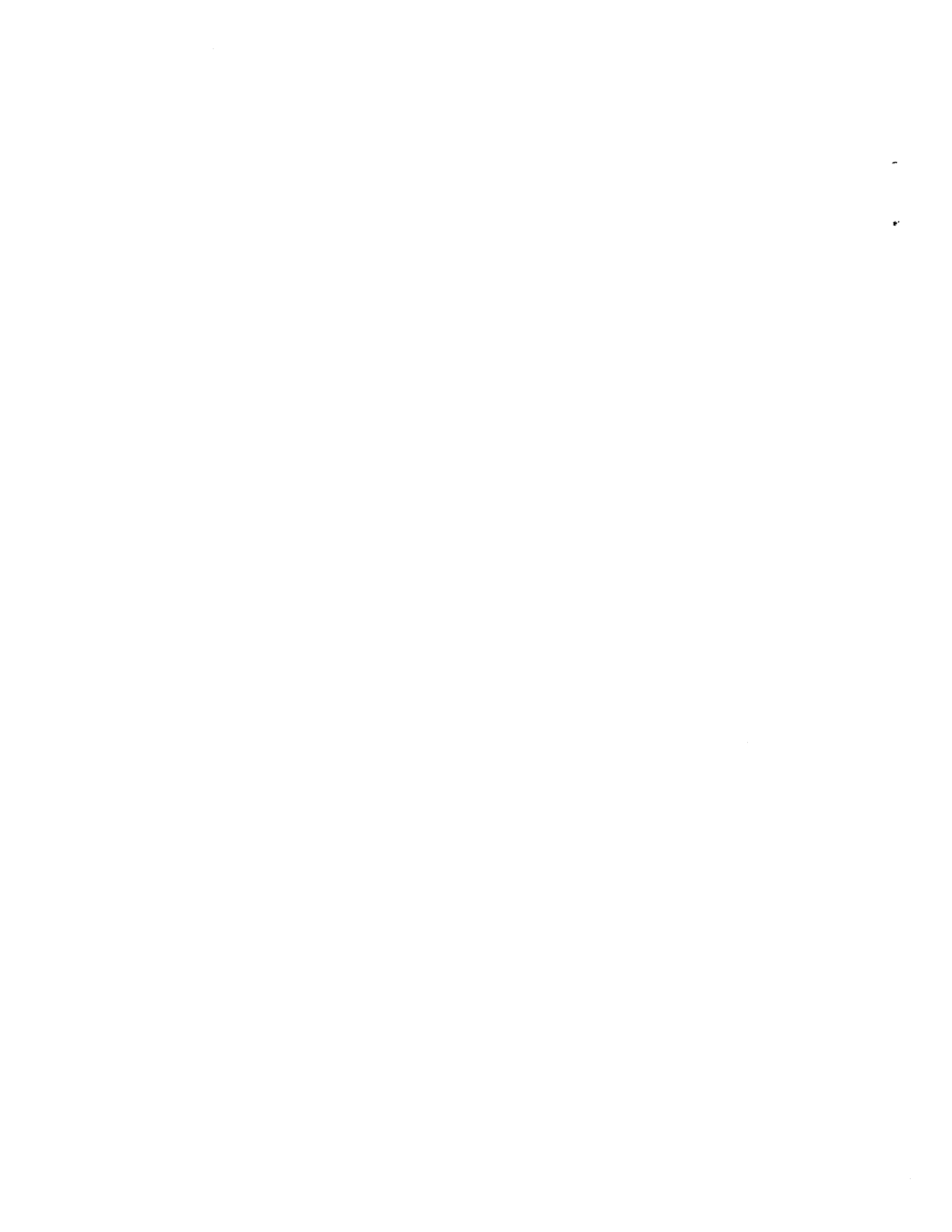

3.11 35 mm. Nikon Camera (SEB33100008):

This small format still camera is a space-modified version of the manually advanced, Nikon FTN 35 mm. single lens reflex camera. The 55 mm., f/1.2, Lens (see 3.12) is used with this camera body that incorporates thru-the-lens coupled light metering. This manual Nikon system has been used for low light-level and interior CM photography during the latter Apollo missions.

3.11.1 Significant Configurations:

<u>Configuration</u>	<u>Purpose</u>
-301	Apollo flight unit

3.11.2 Characteristics:

- Manufactured by Nippon Kogaku K.K., Tokyo, Japan, and distributed by Ehrenreich Photo-Optical Industries, Inc., Garden City, N.Y. 11530.
- Weight (w/o film or lens) - 1.8 lbs. (818 g.)
Envelope - 5.80 x 4.02 x 2.71 in. (14.7 x 10.2 x 6.9 cm.)
Volume - 63.2 in.³ (1035 cm.³)
- The included focal plane shutter has the following settings: T (Time), B (Bulb), 1, 1/2, 1/4, 1/8, 1/15, 1/30, 1/60, 1/125, 1/250, 1/500, and 1/1000 second. A standard connector for X-synchronization with the shutter at 1/60 sec. or lower shutter speed is provided.
- Accepts lenses with the commercial Nikon mounting. Only the 55 mm., f/1.2 Lens (see 3.12) has been used on this camera body in manned space flight.
- Camera viewfinder shows the full thru-the-lens coverage, shutter speed setting, and the light meter needle and matching indicator. The viewfinder can be removed easily to permit waist-level camera operation or replacement of the focusing screen.
- The thru-the-lens, match-needle, light measuring system incorporated in the viewfinder is settable for film speeds of ASA 6 thru 6400 and is coupled to the aperture ring of the lens.
- Film, contained in the special Film Cassette (see 3.4), is installed and threaded in the camera by the operator. The film must be rewound into its cassette before removal from the camera.

- The camera frame counter indexes with each film advancement to a maximum of 72. The even numbers of exposed frames are visible through the counter window.
- The camera incorporates controls for locking the mirror up and for previewing the depth-of-field.
- Includes a 1/4 x 20 threaded receptacle for mounting (see 3.15).
- The manual Nikon camera has been qualified for use in the Apollo vehicles.

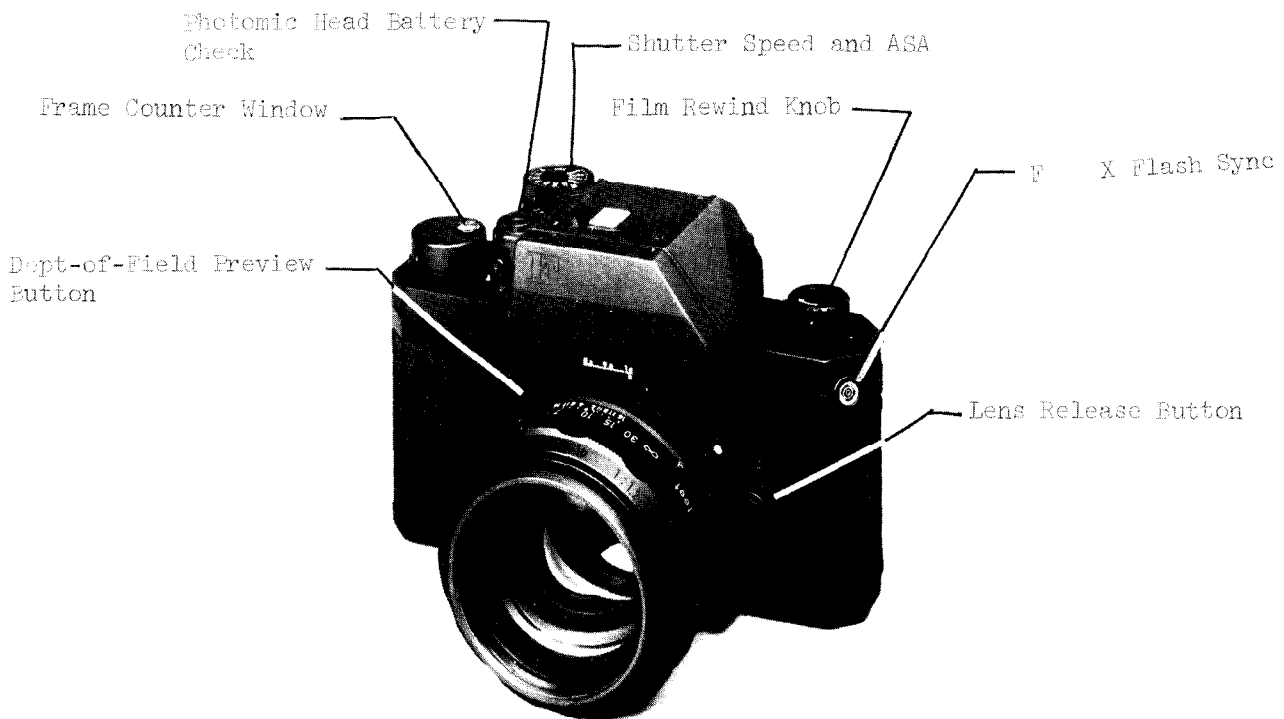

Figure 3.11-1 - 35 mm. Nikon Camera and Lens

3.12 55 mm. Lens (SEB33100009):

This lens is the standard lens for the manual Nikon camera (see 3.11). The high optical quality and large relative aperture of this lens make it very useful for low light-level photography.

3.12.1 Significant Configurations:

<u>Configuration</u>	<u>Purpose</u>
-301	Apollo flight unit

3.12.2 Characteristics:

- Manufactured by Nippon Kogaku K. K., Tokyo, Japan, and distributed by Ehrenreich Photo-Optical Industries, Inc., Garden City, N.Y. 11530.
- The mechanical and optical characteristics of this lens are identical to the 55 mm. Lens, P/N SEB33100773, (see 3.2); however, there are no white engravings on the outer surface of the focus ring.
- This lens is qualified for use in the Apollo vehicles.

3.13 Polarizing Filter Assembly (SEB33100888):

The Polarizing Filter Assembly has been used on the manual Nikon camera (see 3.11 and 3.12) during low light-level photography on the latter Apollo missions. The filter is a standard linear polarizing filter modified for manned space flight.

3.13.1 Significant Configurations:

<u>Configuration</u>	<u>Purpose</u>
-301	Apollo flight unit

3.13.2 Characteristics:

- Manufactured by Nippon Kogaku K.K., Tokyo, Japan, and distributed by Ehrenreich Photo-Optical Industries, Inc., Garden City, N. Y. 11530.
- Weight - 0.12 lbs. (52 g.)
Envelope (less tab) - 0.50 x 2.60 Dia. in. (1.27 x 6.60 Dia. cm.)
Volume - 2.7 in.³ (43.5 cm.³)
- The filter is a Nikon Polar type modified to include a short tab and to limit filter rotation to 90°. This filter requires an exposure increase of 1 to 2 stops, depending on the polarization of the light source.
- This filter assembly is screwed onto the front of the lens (see 3.12) by the camera operator. When the assembly is tightened snugly on the lens, the filter material can be rotated 90° with the tab.
- The Polarizing Filter Assembly is qualified for use in the Apollo vehicles.

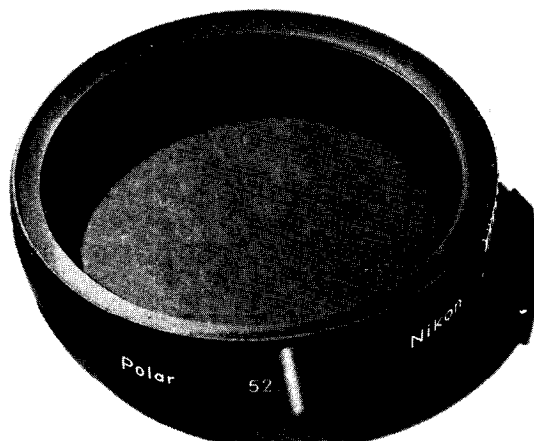

Figure 3.13-1 - Polarizing Filter Assembly

3.14 35 mm. Filter Assembly (SEB33100889):

This filter assembly is a single, screw-in type in either a red or blue color. Both configurations have been used on the manual Nikon camera (see 3.11 and 3.12) during low light-level photography on the latter Apollo missions.

3.14.1 Significant Configurations:

<u>Configuration</u>	<u>Purpose</u>
-301	Apollo flight unit; Corning #2412 red
-302	Apollo flight unit; Corning #530 blue

3.14.2 Characteristics:

- Manufactured by the Dudley Observatory, Albany, N.Y. 12205.
- Weight - 0.03 lbs. (15 g.)
Envelope - 0.35 x 2.40 Dia. in. (0.89 x 6.10 Dia. cm.)
Volume - 1.6 in.³ (26 cm.³)
- The filter materials are obtained from Corning Glass Works, Corning, N.Y. 14830 and are:
 - (-301) - Corning red #2412
 - (-302) - Corning blue #530
- This filter assembly is screwed onto the front of the lens (see 3.12) by the camera operator.
- These filters are qualified for use in the Apollo vehicles.



Figure 3.14-1 - 35 mm. Filter Assemblies

3.15 35 mm. Camera Bracket (SEB33100784):

This camera bracket is used for mounting the manual Nikon camera (see 3.11) in the right-hand CM rendezvous window for low light-level photography during the latter Apollo missions.

3.15.1 Significant Configurations:

<u>Configuration</u>	<u>Purpose</u>
-301	Apollo flight unit

3.15.2 Characteristics:

- Manufactured by Technical Services Division, NASA-MSD, Houston, Texas 77058.
- Weight - 0.40 lbs. (182 g.)
Envelope - 9.65 x 3.70 x 1.30 in. (24.5 x 9.4 x 3.3 cm.)
Volume - 46.4 in.³ (760 cm.³)
- This bracket attaches to the CM right-hand rendezvous window DAC bracket. The 35 mm. Camera Bracket permits two alignment orientations of the camera--along the CM X-axis and pitch 30° up from the X-axis.
- The 35 mm. Camera Bracket is qualified for use in the Apollo vehicles.

Spacecraft Bracket
Interface

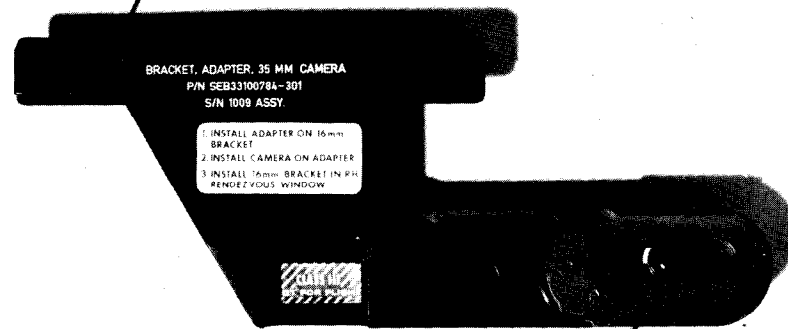

Camera Interface

Figure 3.15-1 - 35 mm. Camera Bracket

3.16 35 mm. Accessory Bracket Assembly (SEC33100945):

This accessory bracket is used for mounting the Automatic Flash Assembly (see 3.19) on the 35 mm. manual Nikon Camera (see 3.11) or motorized 35 mm. Nikon camera (see 3.1) for operational photography.

3.16.1 Significant Configurations:

<u>Configuration</u>	<u>Purpose</u>
-301	Skylab flight unit

3.16.2 Characteristics:

- Manufactured by Technical Services Division, NASA, Houston, Texas 77058.
- Weight - .1 lbs. (45g)
Envelope - 2.2 x 1.6 x 1.04 in. (5.6 x 4.1 x 2.6 cm.)
Volume - 3.7 in.³ (60.6 cm.³)
- This bracket attaches to the 35 mm. Nikon camera (see 3.1 and 3.11). The 35 mm. accessory bracket permits the attachment of the automatic flash to the camera body.
- The 35 mm. accessory bracket assembly is qualified for use in the Skylab vehicles.

3.17 E2 Extension Tube (SEC33100895):

The E2 extension tube is used on the manual Nikon camera (see 3.11) and the 55 mm. lens (see 3.12). The tube is placed between the camera body and lens for certain Skylab student experiment photographs.

3.17.1 Significant Configurations:

<u>Configuration</u>	<u>Purpose</u>
-301	Close-up pictures for certain Skylab student experiments

3.17.2 Characteristics:

- Manufactured by Nippon Kogaku, K.K., Tokyo, Japan, and distributed by Ehrenreich Photo-Optical Industries, Inc., Garden City, New York 11530.
- Weight - .20 lbs. (90g)
Envelope - .73 x 2.42 dia. in. (1.85 x 6.15 dia. cm.)
Volume - 3.36 in.³ (55 cm.³)
- Data for 55 mm. visible lens
Focus - 10.5 to 12.9 in. (26.6 to 32.7 cm.)
Magnification - 1/2.8 to 1/4
Object Area - 3.7 x 5.6 in. to 2.6 x 3.9 in. (9.5 x 14.3 cm. to 6.6 x 9.9 cm.)
- The E2 extension is placed between the Nikon camera body and 55 mm. visible lens (see 3.11 and 3.12) by the camera operator.
- E2 extension tube is qualified for use in the Skylab vehicle.



Figure 3.17-1 - E² Extension Tube

3.18 35 mm. Lens (SEC33100938):

This lens is a wide angle lens for the manual Nikon camera (see 3.11) and/or motorized Nikon camera (see 3.1). The high optical quality and large relative aperture of this lens make it very useful for low light level wide angle interior photography.

3.18.1 Significant Configurations:

<u>Configuration</u>	<u>Purpose</u>
-301	Skylab general interior and close-out photography

3.18.2 Characteristics:

- Manufactured by Nippon Kogaku K.K., Tokyo, Japan, and distributed by Ehrenreich Photo-Optical Industries, Inc., Garden City, New York 11530.
- Weight - 0.96 lbs. (433g)
Envelope - 3.21 x 2.63 dia. in. (8.15 x 6.7 dia. cm.)
Volume - 17.4 in.³ (283.6 cm.³)
- Field-of-view - 37° x 53°, 62° diagonal
- Focus range - 1 foot to infinity with marking at infinity and 1, 1.25, 1.5, 2, 2.5, 3, 4, 5, 7, and 15 feet.
- Aperture f/1.4 thru f/22 with detents at each full stop value.
- Accepts 52 mm. (0.75 mm. pitch) screw-in or 54 mm. OD slip-on filter.
- This lens is qualified for Skylab vehicles.



Figure 3.18-1 - 35 mm. Lens

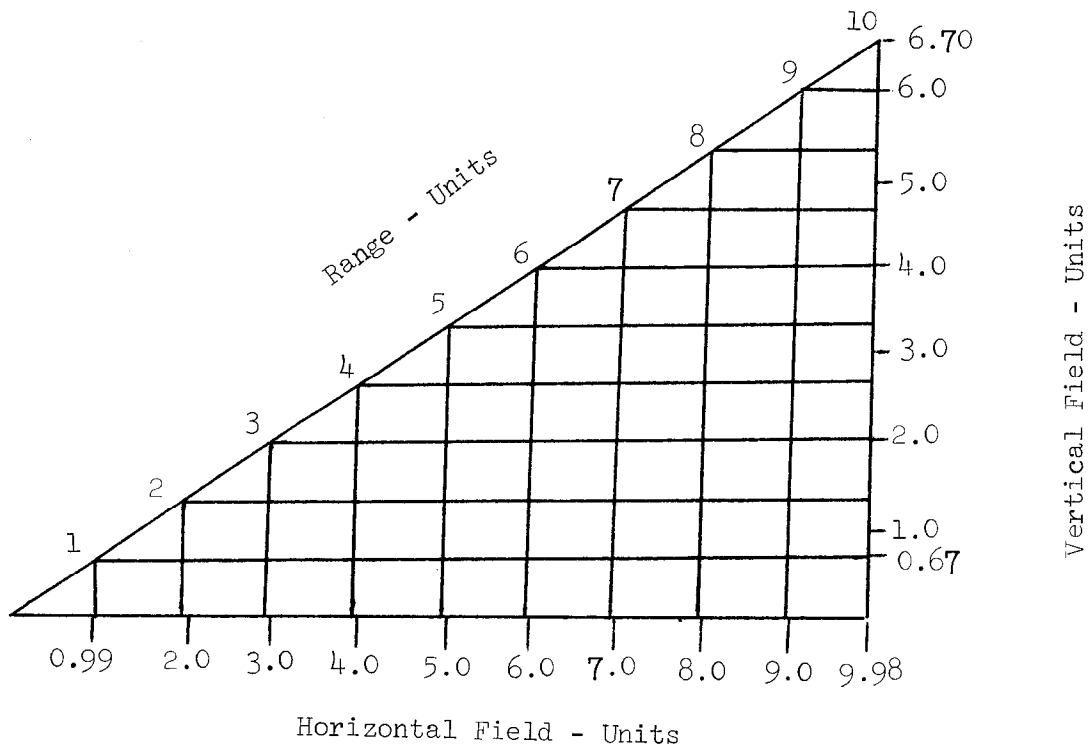

Figure 3.18-2 - Field-of-View

3.19 Automatic Flash Assembly (SEC33100939):

The Automatic Flash Assembly is a modification to the Honeywell Strobunar 360 commercial unit. This flash is intended for general operational photographic use inside the OWS with the Nikon Manual Camera (SEB33100008 - operational visible camera).

3.19.1 Significant Configurations:

<u>Configuration</u>	<u>Purpose</u>
-301	Skylab unit

3.19.2 Characteristics:

- Manufactured by Honeywell Photo Products Division, Littleton, Colorado 80120.
- Weight - 0.75 lbs.
Envelope - 3.8" x 3.3" x 1.7"
Volume - 21.32 cu. inches
- Field-of-view: 50° x 50° Flash
15° x 15° Automatic Sensor
- Flash range:
Automatic Mode
Range 1 3 ft. to 13 ft.
Range 2 3 ft. to 12 ft.
Range 3 3 ft. to 8 ft.
Manual Mode
Range 2 ft. to 22 ft.
Guide Number 103 (Approximate) ASA 160 film

B

- Flash speed:
Automatic Mode
1/70,000 to about 1/4,000 second
Manual Mode
1/4,000 second

- Recycle time: 3 to 10 seconds depending on battery charge.
- Neon light indicates capacitor is charged and unit is ready to flash.
- The Flash is powered by interchangeable rechargeable (ground only) nickel-cadmium battery packs P/N SEC33100940 (see 3.20).
- The Flash attaches to the Nikon Camera by the Camera Accessory Bracket Assembly, P/N SEC33100945 (See 3.16).

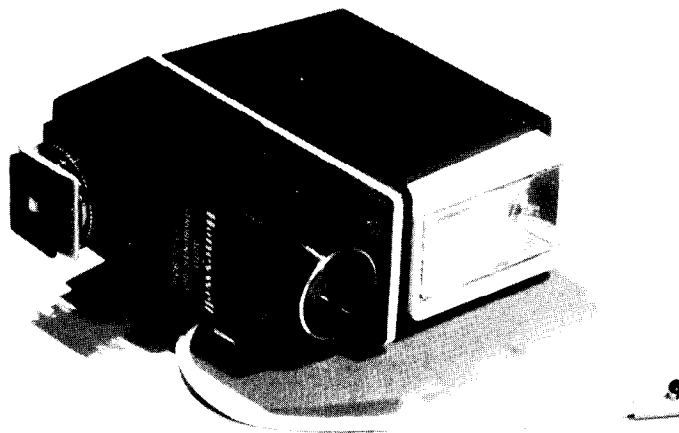

Figure 3.19-1
Automatic Flash Assembly

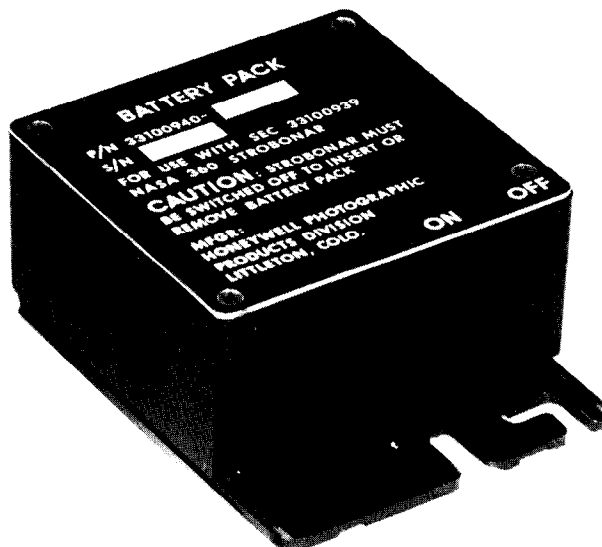

Figure 3.19-2
Automatic Flash Assembly Battery Pack

3.20 Automatic Flash Assembly Battery Pack (SEC33100940):

The Battery Pack is the power source for the Automatic Flash Assembly (SEC33100939). Battery Packs are easily removed and replaced inflight.

3.20.1 Significant Configurations:

<u>Configuration</u>	<u>Purpose</u>
-301	Skylab unit

3.20.2 Characteristics:

- Manufactured by Honeywell Photo Products Division, Littleton, Colorado 80120.
- Weight - 0.90 lbs.
Envelope - 1.5" x 3.4" x 2.8"
Volume - 14.28 cu. in.
- The power source consists of two D-size nickel-cadmium batteries spotwelded together. The nominal open circuit voltage is 2.50 VDC with sufficient capacity for approximately 200 flashes per battery pack.
- The shape of the battery pack prohibits incorrect installation on the flash unit. In addition, an on-off switch safety has been incorporated into the battery pack so that it cannot be installed on or removed from the flash unit if the switch is in the on position.

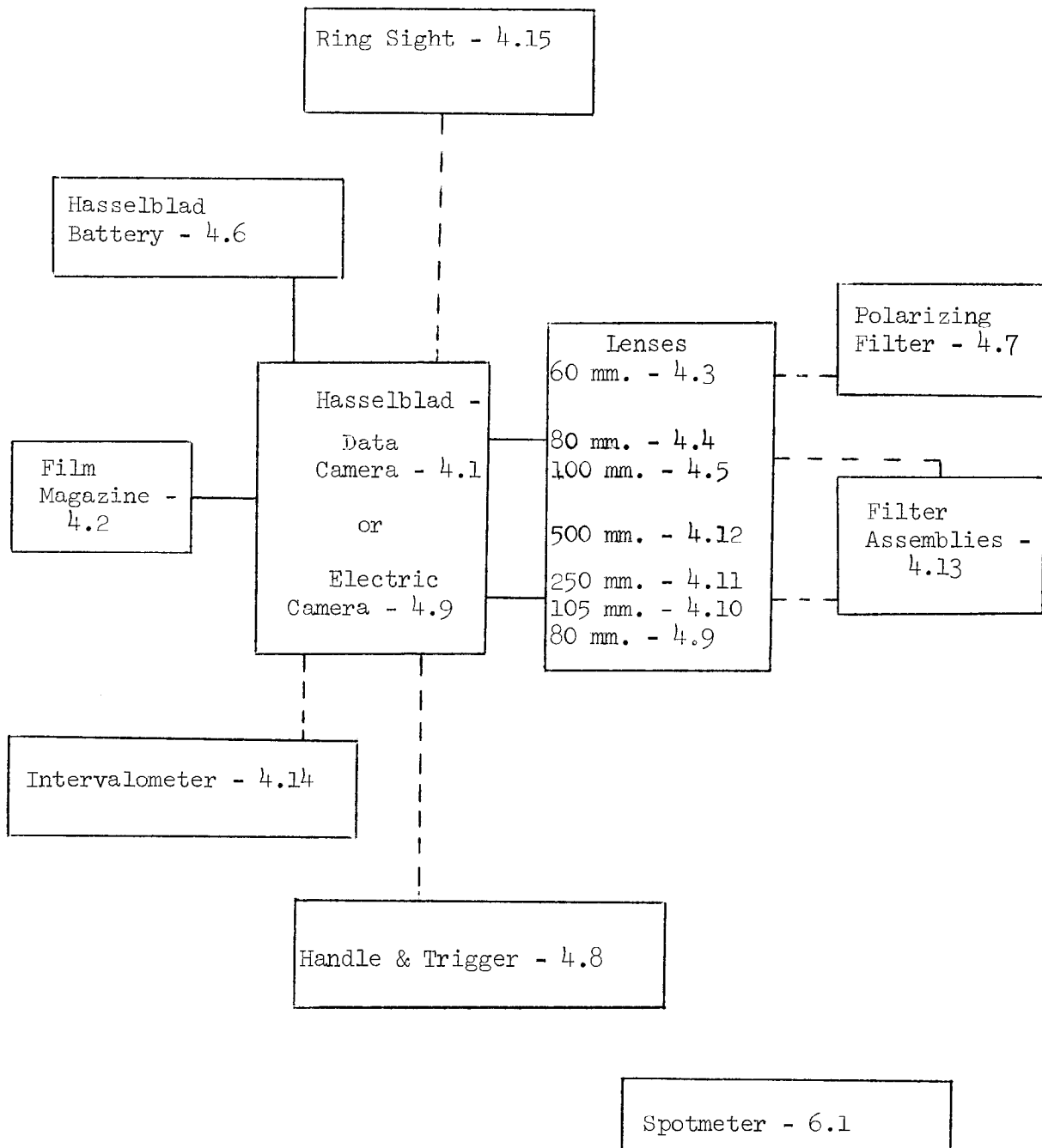

4.1 Hasselblad Data Camera (HDC) (SEB33100040):

The Hasselblad Data Camera (HDC) is a rugged version of the commercial electric Hasselblad camera, 500 EL, and is used for medium resolution, photogrammetric photography during the Apollo and Skylab missions. This camera incorporates a glass reseau plate positioned immediately in front of the film plane. The reseau plate places a pattern of precision crosses on each photograph to facilitate photogrammetric utilization of the photography.

4.1.1 Significant Configurations:

<u>Configuration</u>	<u>Purpose</u>
-305	Apollo CM, LM, and lunar surface flight unit for missions previous to Apollo 15.
-307	Apollo LM and lunar surface flight unit for Apollo 15 and subsequent missions.
-309	Apollo LM and lunar surface flight unit for use with the 500 mm. Lens (see 4.12).
-310	Skylab flight unit; black exterior.

4.1.2 Characteristics:

- Manufactured by Victor Hasselblad AB, Goteborg, Sweden, and distributed by Paillard Inc., Linden, New Jersey 07036.
- Weight (with batteries) - 3.10 lbs. (1410 g.).
Envelope - 5.75 x 3.86 x 4.77 in. (14.6 x 9.8 x 12.1 cm.).
Volume - 106.0 in.³ (1735 cm.³).
- The HDC has a 4.0 mm. thick glass plate rigidly mounted in the rear opening of the camera. An array of 25 reseau crosses is engraved on the rear surface of the plate to facilitate precision geometrical calibration of the film and of the camera and lens optics. The glass plate also incorporates a fine rim on each vertical edge to provide minimal but positive contact with the film. The -307 and -310 camera plates include a small engraving of the last two digits of the camera serial number located in the top center of plate.

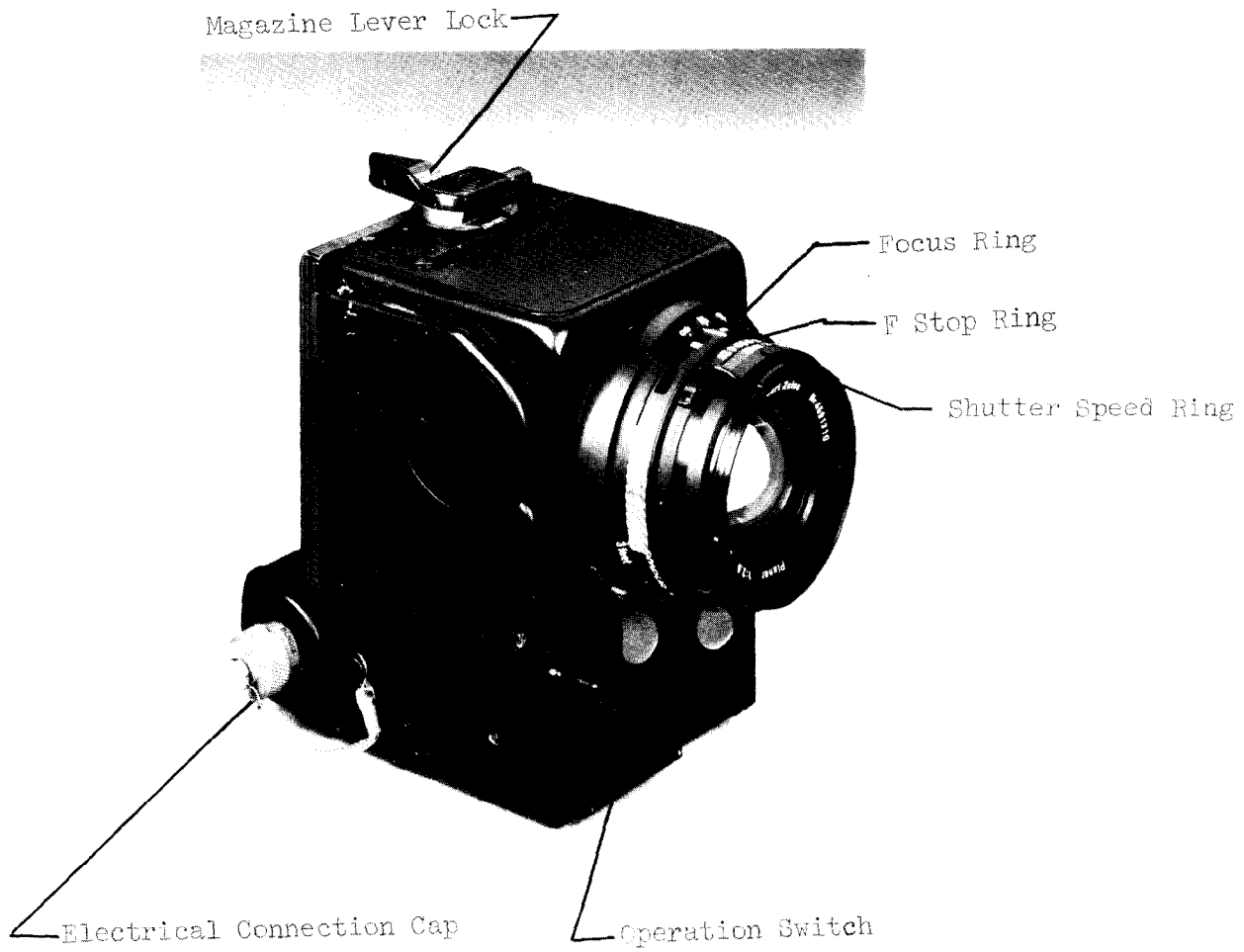

Figure 4.1-1 Hasselblad Data Camera, Front View

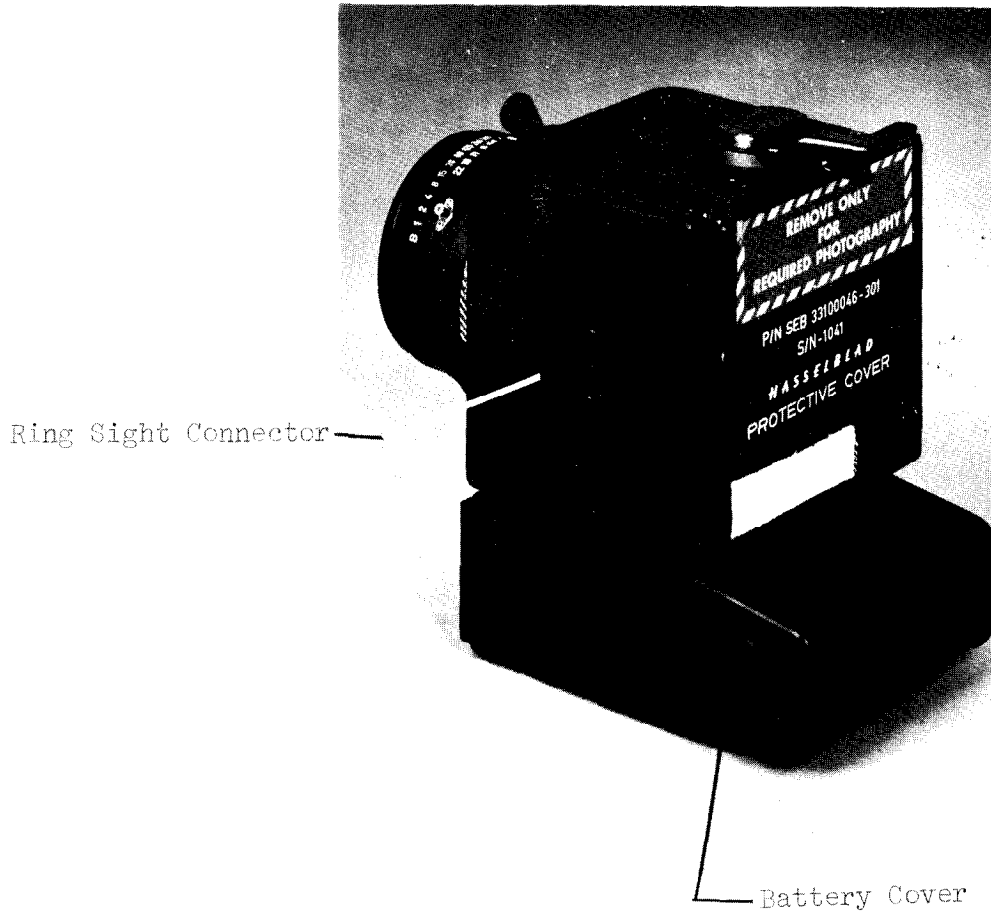

Figure 4.1-2 - Hasselblad Data Camera, Rear View

**THE RESEAU
GLASS PLATE**

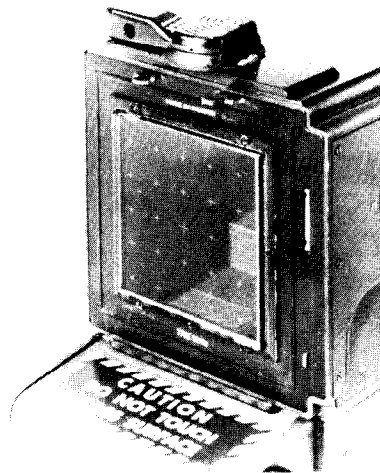

Figure 4.1-3 - HDC Glass Reseau Plate

NASA 5-69-2211

RESEAU GRID LAYOUT

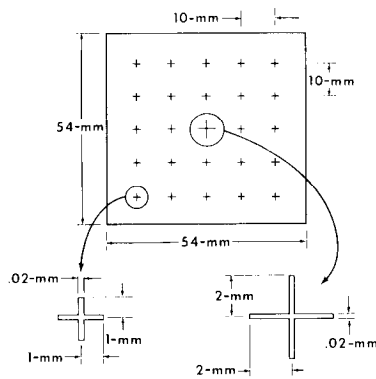

Figure 4.1-4 - Reseau Grid Layout

- The HDC Cover, P/N SEB33100046-301, is provided for protection of the glass plate during handling and storage. The cover is attached to the camera in the same manner as the Film Magazine (see 4.2). The HDC Cover is removed only when a film magazine is to be installed.
- The HDC freely accepts the 60 mm., 80 mm., and 100 mm. Lenses (see 4.3, 4.4, and 4.5) specially designed to compensate for the glass reseau plate. The -309 HDC is used with a 500 mm. Lens (see 4.12) adjusted for the glass plate and lunar surface operations.
- The HDC accepts interchangeable film magazines (see 4.2) containing 70 mm. film. The camera provides the locking mechanism for positive attachment and the drive force for film advancement. The glass plate of the HDC presses the film against the magazine pressure platen thereby determining the actual film plane location.
- The motor drive of the HDC provides automatic recocking of the lens shutter and film advancement after each exposure. The exposure is initiated by depressing the operate button on the camera front. Releasing the operate button activates the camera motor which automatically stops at the completion of the drive functions (approximately 1.0 second run duration).
- The HDC shutter release solenoid and drive motor are powered by two self-contained, replaceable, Ni-Cd batteries (see 4.6) with a capacity sufficient for approximately 3,000 camera cycles. The camera may be operated with only one battery for approximately 1,500 camera cycles.
- The HDC electrical circuit normally is fused with a replaceable 1.7 amp. tubular fuse. A metal slug is included as a spare (except for -310). For lunar surface operations (-305, -307, and -309), the roles of the fuse and the slug are reversed. Two 1.7 amp. fuses are provided in the Skylab HDC configuration (-310). The batteries, metal slug, and/or fuse(s) are easily accessible through the battery compartment door.
- An accessory connector (Deutsch bayonet type UR40-8-7S) is provided for electrical control of the HDC operation. The Intervalometer (see 4.14) can be connected for camera operation at a precisely repeated interval; the DAC Remote Control Cable (see 2.16) can be installed for operator initiated camera cycles from a remote position. A shutter



Figure 4.1-5 - Lunar Surface HDC/60 mm. Lens Assembly

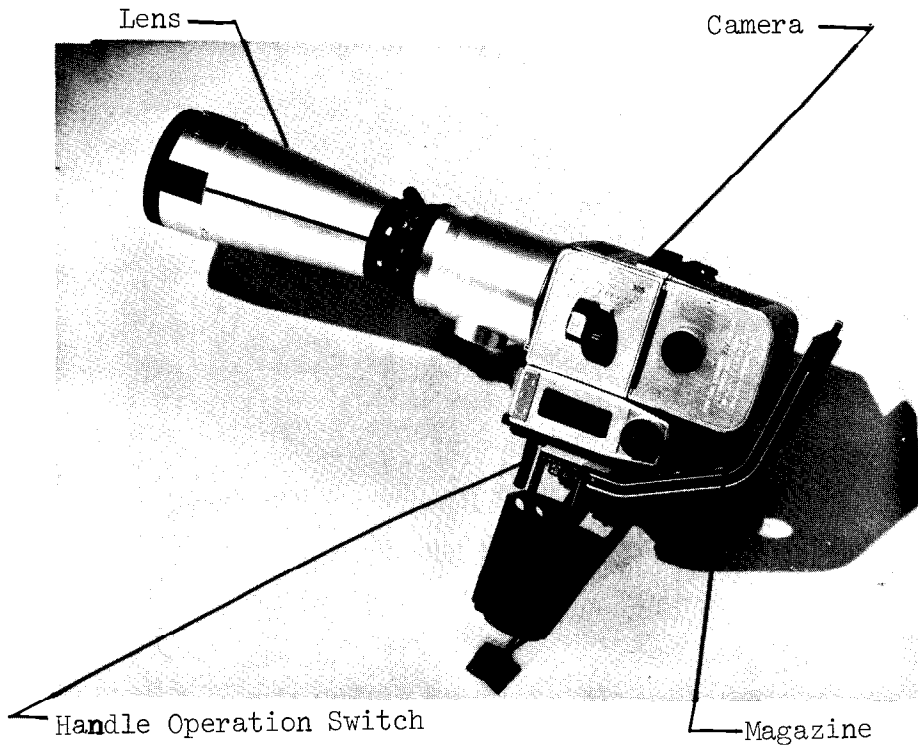

Figure 4.1-6 - Lunar Surface HDC/500 mm. Lens Assembly

operation signal is available in the accessory connector for use as a telemetry data source.

- Includes a quick attachment mounting foot and a 3/8 x 16 threaded hole compatible with CM mounting brackets and the Handle and Trigger Assemblies (see 4.8). Includes a shoe on the left side for attaching the Ring Sight aiming device (see 4.15).
- HDC configurations -305, -307, and -309 are coated with thermal control aluminum paint to moderate the temperature extremes of lunar surface operations. The Skylab HDC (-310) has the natural black anodized exterior.
- The -309 configuration HDC includes a tape covering over the lens mount opening to insure cleanliness of the camera interior during stowage when the 500 mm. Lens (see 4.12) is not installed.
- The HDC is qualified for use in the Apollo and Skylab vehicles and on the lunar surface.

4.2 Film Magazine (SEB33100082):

The Film Magazine is the film container for the Hasselblad Data Camera (HDC) (see 4.1) and the Hasselblad Electric Camera (HEC) (see 4.9). This magazine is darkroom loaded with 70 mm., Type II perforated, film of various thicknesses.

4.2.1 Significant Configurations:

<u>Configuration</u>	<u>Purpose</u>
-215	Apollo CM unit; primarily for use with HEC (see 4.9); black finish.
-217	Apollo CM, LM, and lunar surface unit; primarily for use with HDC (see 4.1); aluminum thermal paint finish and includes a tether ring assembly.
-301	Skylab unit; black finish.

4.2.2 Characteristics:

- Manufactured by Victor Hasselblad AB, Goteborg, Sweden, and distributed by Paillard, Inc., Linden, New Jersey 07036.
- Weight (with film) - 1.40 lbs. (635 g.).
Envelope - 3.54 x 3.94 x 3.45 in. (9.0 x 10.0 x 8.8 cm.).
Volume - 48.1 in.³ (788 cm.³).
- The useful film capacity of the magazine varies with film type and with the amount of preflight sensitometry. With standard base films (4 mil, 102 μ m) such as Kodak 2485 and IIA0, approximately 110 frames are available. Thin base films (2.5 mil, 64 μ m) provide between 160 and 170 frames depending on whether the emulsion is color (S0168, S0368) or black and white (3400, 3401, 3414).
- The magazine must be loaded and unloaded in a photographic darkroom. When in use, the magazine can be removed from the camera at any time and later reinstalled as dictated by the operational requirements.
- A frame counter, located on the right side, indicates every fifth frame with a line and every tenth frame with

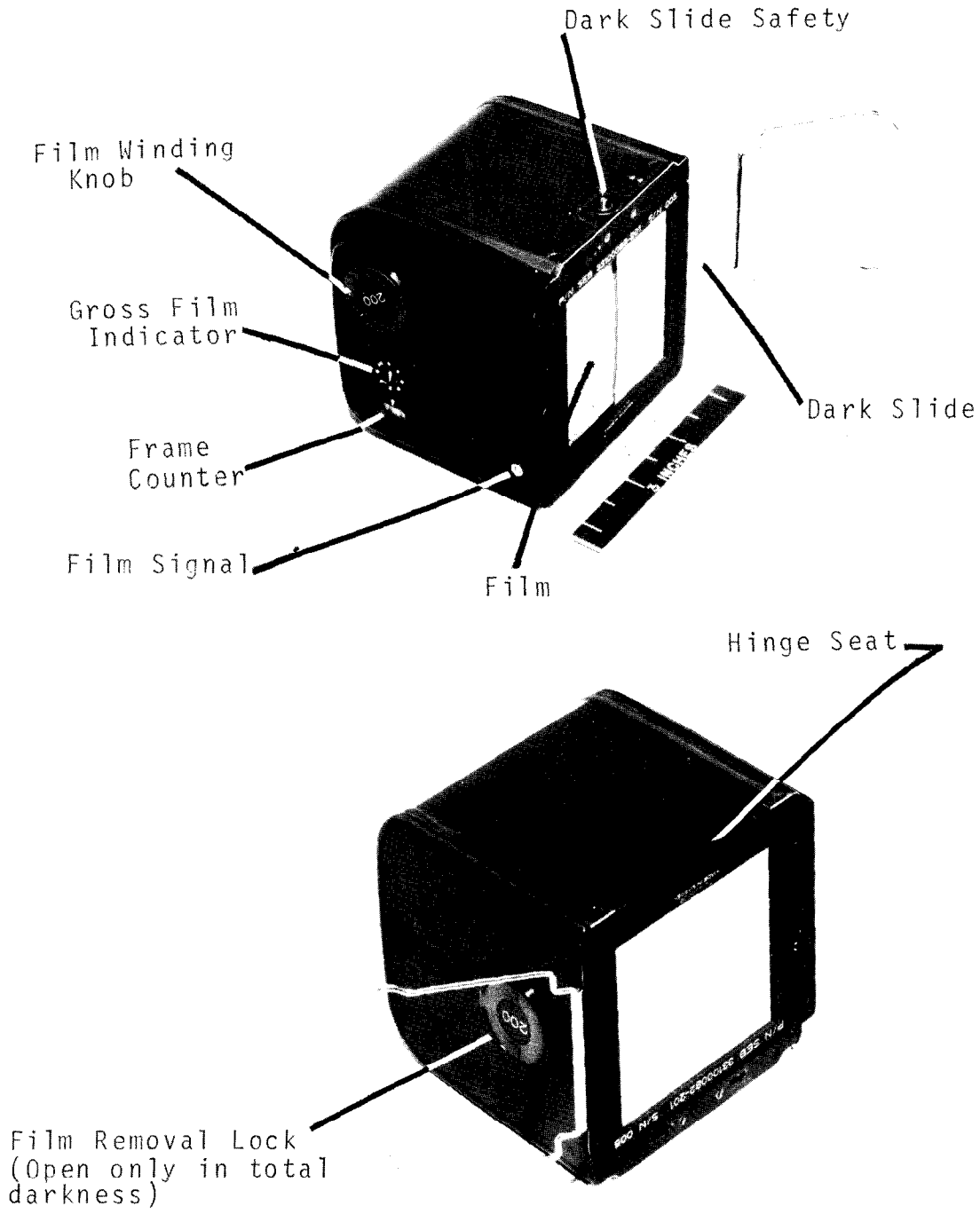

Figure 4.2-1 - Film Magazine (-301) for Skylab Use

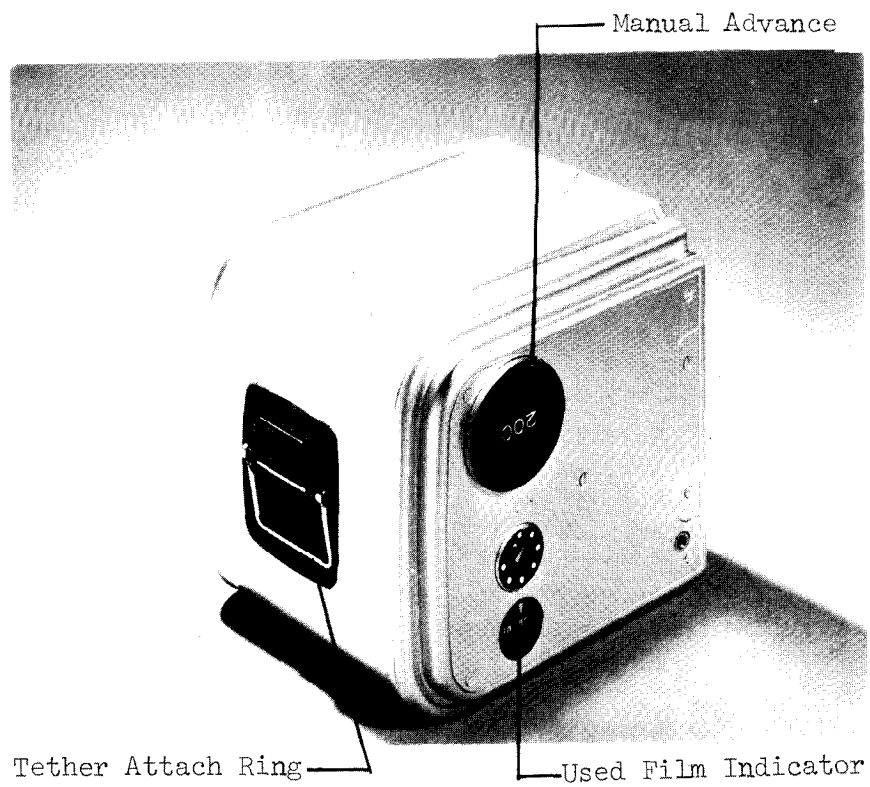

Figure 4.2-2 - Film Magazine (-217) for Lunar Surface Use

a line and a number. The counter indexes with each frame and counts upward to a maximum of 200 frames. The magazine mechanism prohibits camera operation after the film supply has been exhausted.

- A red/white signal, visible on the lower right side, monitors film advancement. A red signal indicates incomplete film advancement to the next frame or an out-of-film condition; camera operation is prohibited as long as the signal is red. During normal operation, the signal will change from white to red to white as the film is advanced. A ring style ratchet knob is provided on the right side to permit any required manual advancement of the film.
- A metal darkslide is included to protect the film whenever the magazine is not installed on the camera.

When the magazine is to be installed on an HDC (see 4.1) (camera with glass reseau plate) (primarily -217 and -301 magazines), the darkslide must be removed prior to installation and not be reinserted until the magazine has been removed from the camera. Failure to do this will result in damage to the glass reseau plate of the HDC. The darkslide should be inserted into the magazine as soon as possible after removal from the camera to reduce light exposure of the film.

Conversely, the darkslide must be inserted fully for installation on an HEC (see 4.9) (nonreseau camera) (primarily -215 magazine). Once the magazine is installed, the darkslide must be removed before the required photography. Camera operation will be prohibited if the darkslide is inserted more than halfway. The darkslide must be inserted fully for magazine removal from an HEC.

- The -217 configuration incorporates a tether ring assembly on the magazine rear. The tether ring can be unstowed and stowed by the suited creman on the lunar surface. This magazine (-217) also is coated with thermal control aluminum paint to moderate the temperature extremes of lunar surface operations.
- The film magazine is qualified for use in the Apollo and Skylab vehicles and on the lunar surface.

4.3 60 mm. Lens (SEB33100048):

The 60 mm. Lens is used on the HDC (see 4.1) on the lunar surface. The lens provides the maximum field-of-view with minimum optical distortion and maximum relative aperture for the HDC system. This lens, designed specifically for the reseau camera body, physically extends the optics well into the camera body.

4.3.1 Significant Configurations:

<u>Configuration</u>	<u>Purpose</u>
-304	Apollo LM and lunar surface flight unit for missions previous to Apollo 15; full aperture range.
-305	Apollo LM and lunar surface flight unit for Apollo 15 and subsequent missions; limited aperture range and improved aperture repeatability.

4.3.2 Characteristics:

- Manufactured by Carl Zeiss, Oberkochen, West Germany, and distributed by Paillard, Inc., Linden, New Jersey, 07036.
- Weight - 1.70 lbs. (771 g.).
Envelope - 5.32 x 4.14 Dia. in. (13.5 x 11.5 Dia. cm.).
Volume - 71.6 in.³ (1174 cm.³).
- Field-of-view - 46.9° x 46.9°; 63.4° diagonal.
The horizontal field is indicated by black lines on the lens barrel top.
- Focus range (-304) - 35 inches to infinity with detents at 5.3, 15, and 74 feet and at infinity. The lens focus ring is marked at 3, 3.5, 4, 5, 6, 8, 10, 15, 30, and 50 feet and at infinity. A label, visible to the suited crewman on the lunar surface, is included on the focus ring and is marked for 3, 3.5, 4, 5, 6, 8, 10, 15, 30, and 74 feet and infinity.

(-305) - 35 inches to 74 feet with detents at 7, 11, and 74 feet. The lens focus ring is marked the same as the -304 lens assembly. The focus label is marked for 3.5, 4, 5, 6, 7, 8, 11, 15, 30, and 74 feet.

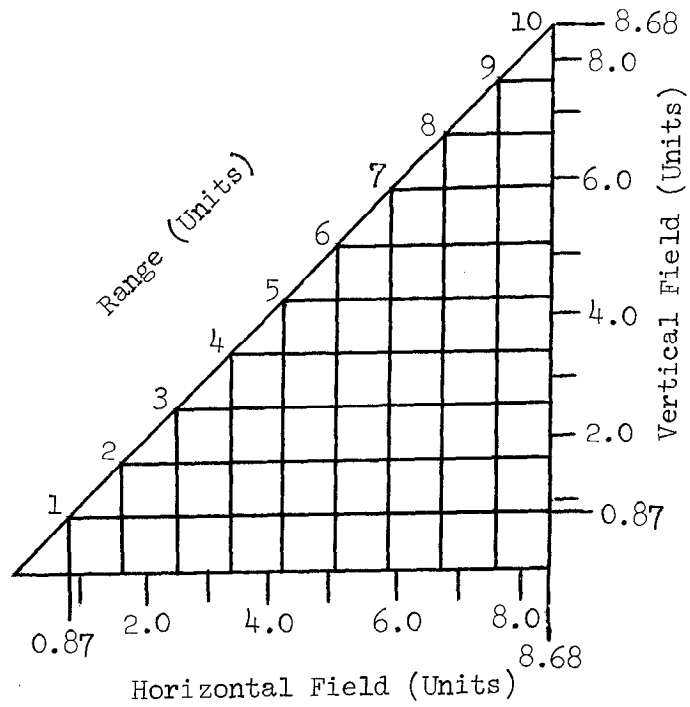
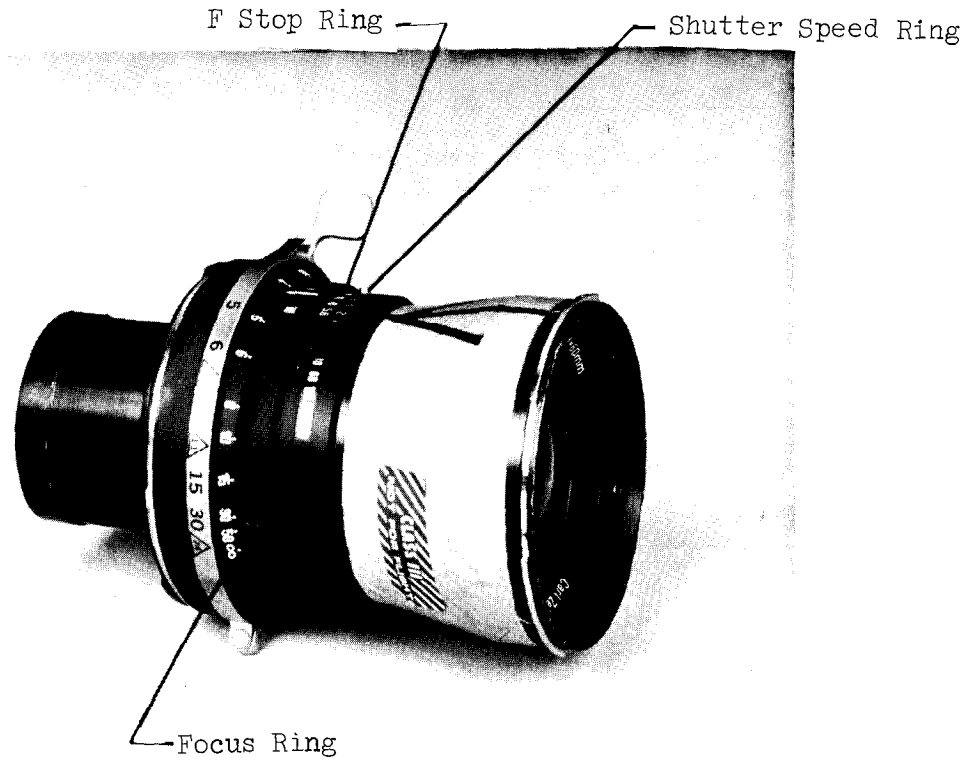

Figure 4.3-1 - 60 mm. Lens and Field-of-view Chart

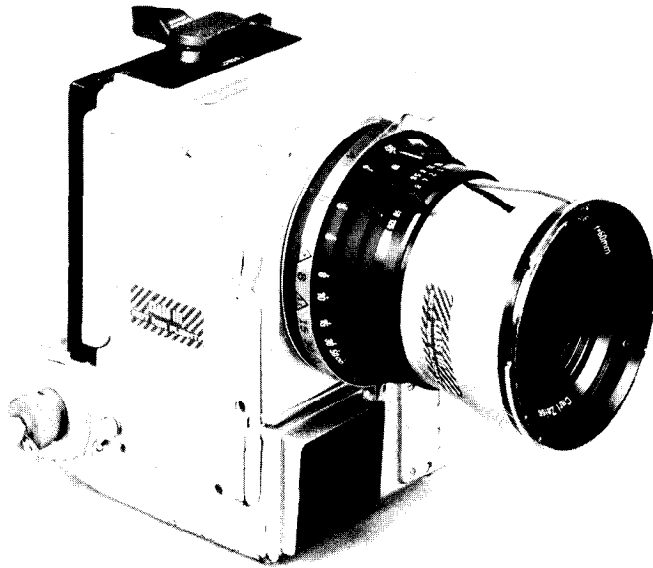
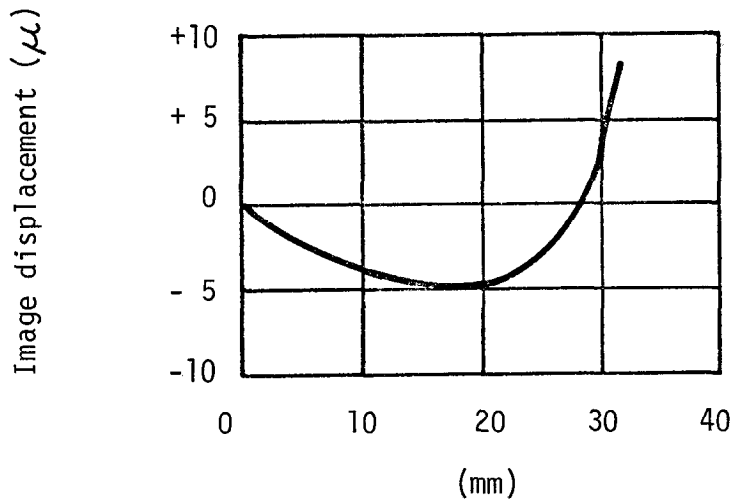

Figure 4.3-2 - 60 mm. Lens Installed on HDC



Data indicate maximum displacement of image from its distortion-free position. A positive value indicates a displacement away from the center.

Maximum aperture

Figure 4.3-3 - 60 mm. Lens Radial Distortion (Typical)

- Closest focus - photo subject should be positioned 27.5 inches from lens front edge. At this setting, the photo field is 25.5 inches square and the depth-of-field at f/5.6 is about 3.5 inches, at f/8 is about 5.0 inches.
- Aperture (-304) - f/5.6 through f/45 with detents at each half stop.
 - (-305) - f/5.6 through f/16 with detents at each full stop.
- Indicators are provided immediately in front of the focus ring to show the acceptable depth-of-field (object range in focus) for any aperture/focus setting.
- Shutter speeds - the included Compur shutter has settings of B (bulb), 1, 1/2, 1/4, 1/8, 1/15, 1/30, 1/60, 1/125, 1/250, and 1/500 second with detents at each value.
- Sturdy tabs are provided on the focus, aperture, and shutter speed control rings to aid the crewman in setting adjustment.
- The optical design of this lens includes the glass reseau plate of the HDC (see 4.1) as an element. This design results in an especially low degree of radial distortion - less than $+10 \mu\text{m}$ across the image field. This lens should not be used on the nonreseau HEC (see 4.9).
- Bayonet filter mounts are provided on the outside of the lens barrel front edge for installation of the Polarizing Filter (see 4.7).
- The outer lens barrel is coated with thermal control aluminum paint to moderate the temperature extremes of lunar surface operations.
- The 60 mm. Lens is qualified for use in the Apollo vehicles and on the lunar surface.

4.4 80 mm. Lens (SEB33100261):

The 80 mm. Lens is a space modification of the commercial equivalent, corrected and adjusted for use with the HDC (see 4.1) glass reseau plate camera body. This lens is intended for general photographic use and has been used in the CM during Apollo and is the lens used with the Skylab HDC (-301).

4.4.1 Significant Configurations:

<u>Configuration</u>	<u>Purpose</u>
-301	Apollo CM and Skylab unit.

4.4.2 Characteristics:

- Manufactured by Carl Zeiss, Oberkochen, West Germany, and distributed by Paillard, Inc., Linden, New Jersey 07036.
- Weight - 1.0 lb. (454 g.).
Envelope - 2.09 x 4.18 Dia. in. (5.3 x 10.6 Dia. cm.).
Volume - 28.7 in.³ (470 cm.³).
- Field-of-view - 36.0° x 36.0°; 49.2° diagonal.
- Focus range - 35 inches to infinity with markings for 3, 3.25, 3.5, 3.75, 4, 4.5, 5, 6, 7, 8, 10, 15, 25, and 50 feet and infinity.
- Closest focus - photo subject should be positioned 30.5 inches from lens front edge.
- Aperture - f/2.8 through f/22 with detents at each half stop.
- Indicators are provided immediately in front of the focus ring to show the acceptable depth-of-field for any aperture/focus setting.
- Shutter speeds - the included Compur shutter has settings of B (bulb), 1, 1/2, 1/4, 1/8, 1/15, 1/30, 1/60, 1/125, 1/250, and 1/500 second with detents at each value.
- Sturdy tabs are provided on the focus, aperture, and shutter speed control rings to aid the crewman in setting adjustment.

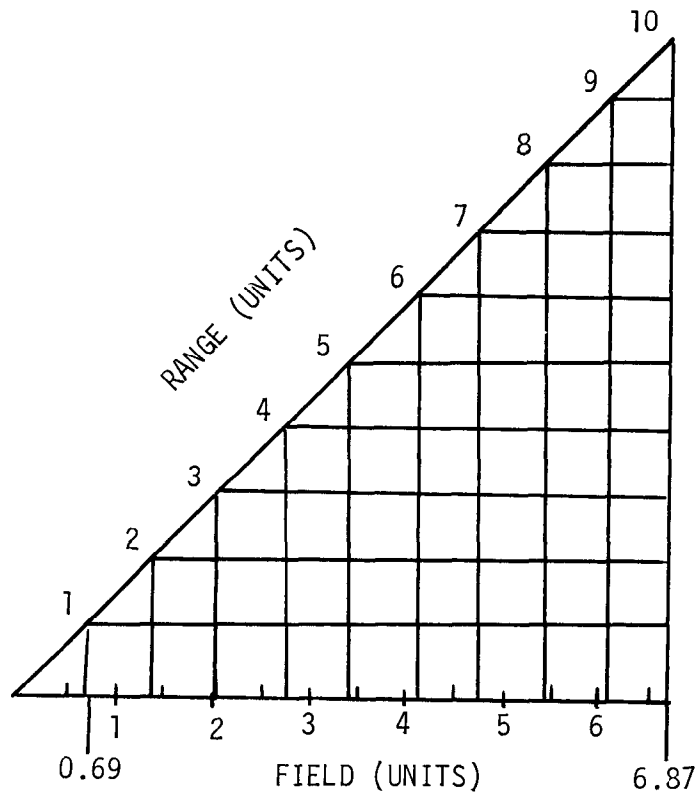
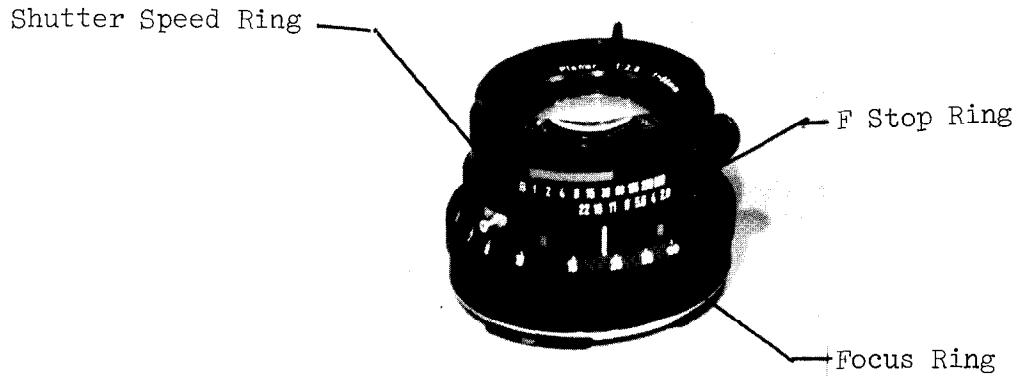
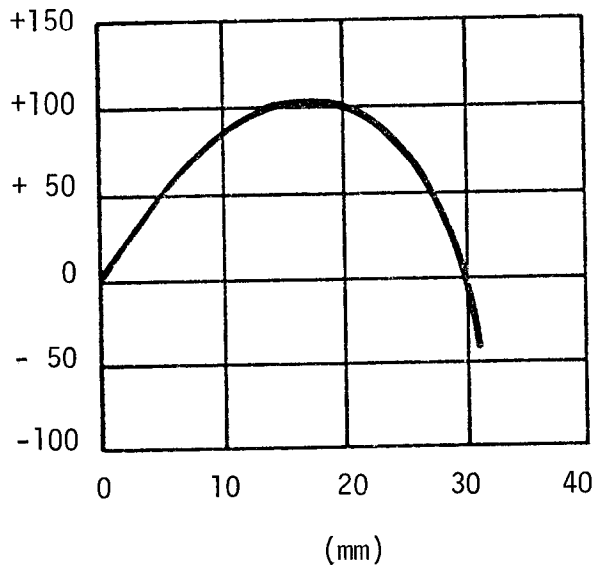

Figure 4.4-1 - 80 mm. Lens and Field-of-View Chart

- The optical design of this lens includes the glass reseau plate of the HDC (see 4.1) as an element. This lens should not be used on the nonreseau HEC (see 4.9).
- The inside and the outside bayonet filter mountings of the commercial lens are included on the lens front. The inside mounts accept the Filter Assemblies (see 4.13).
- The 80 mm. Lens is qualified for use in the Apollo and Skylab vehicles.

Image displacement (μ)



Data indicate maximum displacement of image from its distortion-free position. A positive value indicates a displacement away from the center.

Maximum aperture

Figure 4.4-2 - 80 mm. Lens Radial Distortion (Typical)

4.5 100 mm. Lens (SEB33100041):

The 100 mm. Lens, a space modification of the commercial equivalent, is optically corrected and adjusted for use on the HDC (see 4.1) glass reseau plate camera body. The optical and mechanical properties of this lens are optimized for orbital mapping applications.

4.5.1 Significant Configurations:

<u>Configuration</u>	<u>Purpose</u>
-301	Basic flight unit; not currently in use.

4.5.2 Characteristics:

- Manufactured by Carl Zeiss, Oberkochen, West Germany, and distributed by Paillard, Inc., Linden, New Jersey 07036.
- Weight - 1.15 lbs. (522 g.).
Envelope - 2.54 x 3.52 Dia. in. (6.5 x 9.0 Dia. cm.).
Volume - 24.7 in.³ (40.5 cm.³).
- Field-of-view - 29.2° x 29.2°; 40.6° diagonal.
- Focus range - rigidly fixed for infinity.
- Aperture - f/3.5 through f/22 with detents at f/3.5 and at each half stop from f/4 through f/22.
- A single indicator is provided immediately in front of what would be the focus ring to show the acceptable near depth-of-field for any aperture setting.
- Shutter speeds - the included Compur shutter has settings of B (bulb), 1, 1/2, 1/4, 1/8, 1/15, 1/30, 1/60, 1/125, 1/250, and 1/500 second with detents at each value.
- Sturdy tabs are provided on the aperture and shutter speed control rings to aid the crewman in setting adjustment.
- The optical design of this lens includes the glass reseau plate of the HDC (see 4.1) as an element and results in a low degree of radial distortion - less than + 15 μm across the image field. The static resolution on-axis and across the image field is significantly better than

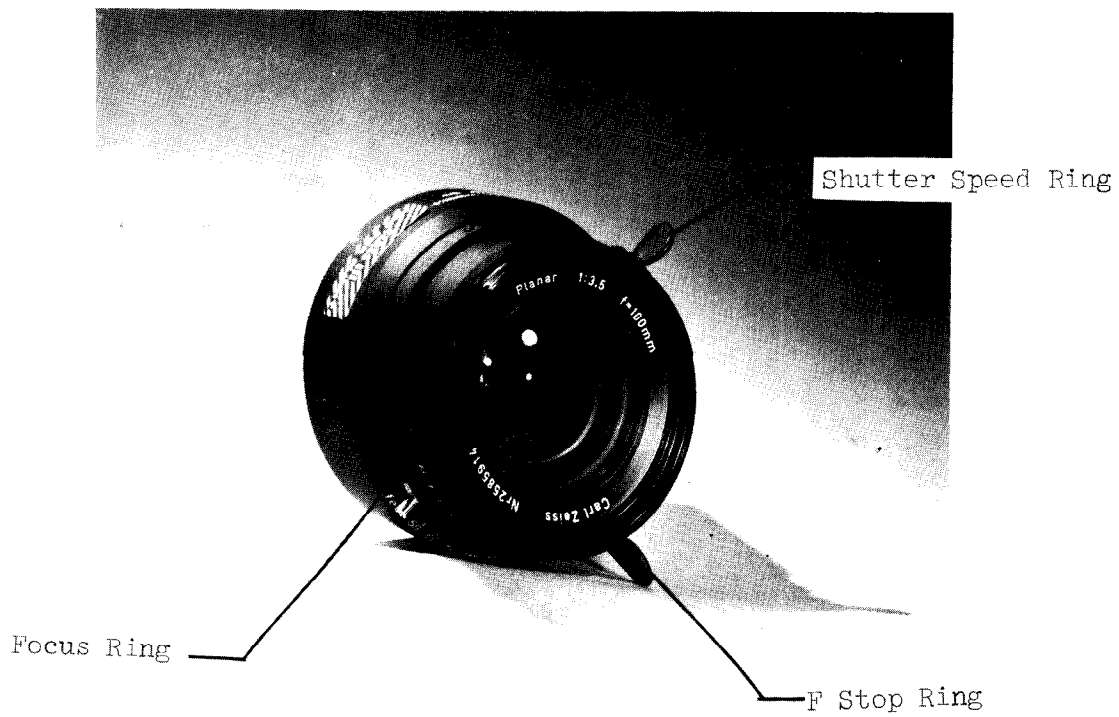
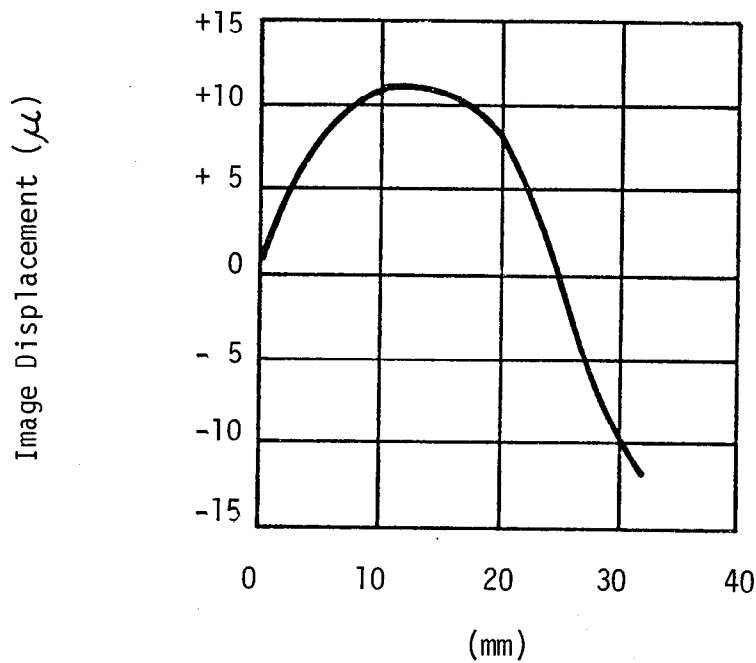

Figure 4.5-1 - 100 mm. Lens



Data indicate maximum displacement of image from its distortion-free position. A positive value indicates a displacement away from the center.

Maximum aperture

Figure 4.5-2 - 100 mm. Lens Radial Distortion (Typical)

that of the 80 mm. lens (see 4.4). By rigidly fixing the focus of this lens, the optical principal point is positioned more repeatedly, thereby improving the mapping usefulness of the photography. This lens should not be used on the nonreseau HEC (see 4.9).

- The inside and the outside bayonet filter mountings of the commercial lens are included on the lens front. The inside mounts accept the Filter Assemblies (see 4.13).
- The 100 mm. lens is qualified for use in the Apollo vehicles.



4.6 Hasselblad Battery (SEB33100174):

The Hasselblad Battery is the power source for the HDC (see 4.1) and the HEC (see 4.9). This battery can be replaced easily by the camera operator.

4.6.1 Significant Configurations:

<u>Configuration</u>	<u>Purpose</u>
-201	Apollo and Skylab unit.

4.6.2 Characteristics:

- Manufactured by Technical Services Division, NASA MSC, Houston, Texas 77058.
- Weight - 0.33 lb. (150 g.).
Envelope - 1.92 x 1.36 Dia. in. (4.9 x 3.5 Dia. cm.).
Volume - 2.8 in.³ (45.7 cm.³).
- The power source is five rechargeable nickel cadmium cells type 6.0 V/500 BH per Gould-National Batteries, Inc., St. Paul, Minnesota 55114. The cells are stacked and spotwelded together by Gould and potted by NASA. The nominal open circuit voltage is 6.25 VDC with sufficient capacity for 1,500 camera cycles per battery.
- The shape of the battery prohibits incorrect installation and connection in the camera. The positive (+) end of the battery must be inserted into the camera for proper installation.
- The Hasselblad Battery has been qualified for use in the Apollo and Skylab vehicles and on the lunar surface.

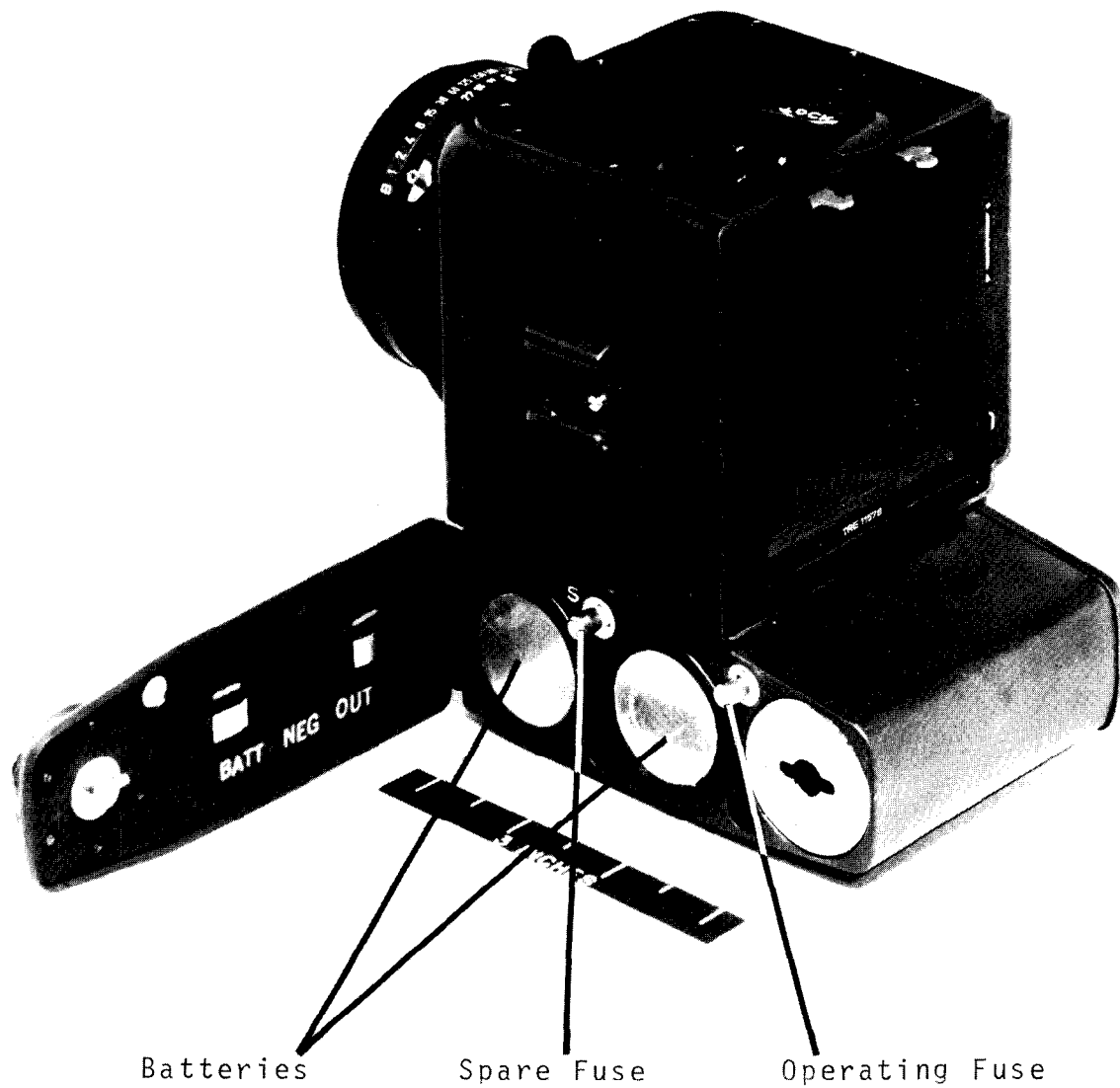

Figure 4.6-1 - Hasselblad Battery and Installation

4.7 Polarizing Filter (SEB33100113):

The Polarizing Filter is used on the 60 mm. Lens (see 4.3) for geological polarization studies on the lunar surface. The filter is a standard linear polarizer which can be rotated 90° by the camera operator.

4.7.1 Significant Configurations:

<u>Configuration</u>	<u>Purpose</u>
-305	Apollo LM and lunar surface unit.

4.7.2 Characteristics:

- Manufactured by Victor Hasselblad AB, Goteborg, Sweden, and distributed by Paillard, Inc., Linden, New Jersey 07036.
- Weight - 0.20 lb. (90.8 g.).
Envelope - 0.42 x 4.07 Dia. in. (1.1 x 10.0 Dia. cm.)
Volume - 5.5 in.³ (90.0 cm.³).
- The filter material is a glass laminated neutral polarizer, KN36C Type C-SP-C-F-G-E, ground optically flat to 10 fringes or better, manufactured by the Polaroid Corp., Cambridge, Massachusetts 02139.
- The filter assembly attaches and locks on the bayonet mounts on the front of the 60 mm. Lens (see 4.3). The camera operator easily can release and remove the assembly during lunar surface operations.
- When the assembly is installed on the lens, the filter material can be rotated through 90° with detents at left, center, and right positions as viewed from the camera rear. The left position sets the polarizing axis to vertical, the center to 45°, and the right to horizontal.
- The Polarizing Filter is qualified for use in the Apollo vehicles and on the lunar surface.

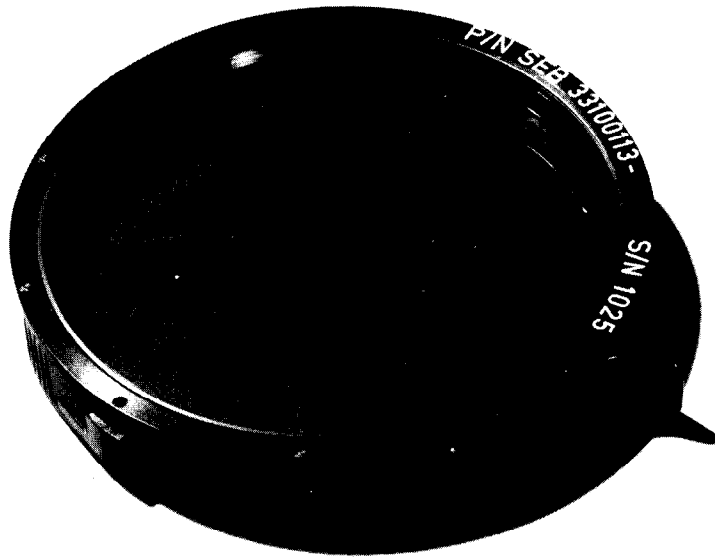

Figure 4.7-1 - Polarizing Filter

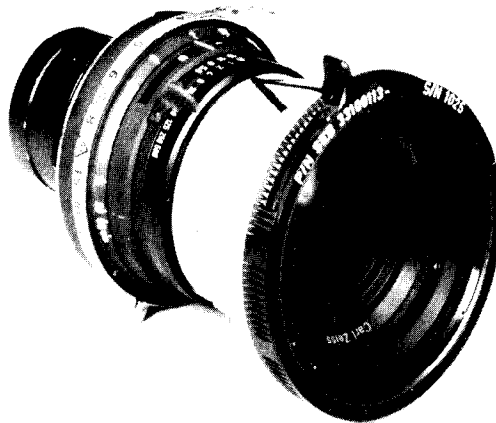

Figure 4.7-2 - Filter Installed on 60 mm. Lens

4.8 Handle and Trigger Assemblies (SEB33100293 and SEB33100294):

The Handle and Trigger Assemblies are used together with the RCU Camera Mount Bracket (Hamilton Standard Part Number SV742170-3) to form a handling and camera actuation facility for the lunar surface Hasselblad camera assembly which includes the HDC (see 4.1), Film Magazine (see 4.2), and the 60 mm. Lens (see 4.3).

4.8.1 Significant Configurations:

<u>Configuration</u>	<u>Purpose</u>
SEB33100293-302A	HDC Handle Apollo unit.
SEB33100294-303	HDC Trigger Apollo unit.

4.8.2 Characteristics:

- Manufactured by Technical Services Division, NASA MSC, Houston, Texas 77058.
- Weight (Handle) - 0.5 lb. (227 g.).
(Trigger) - 0.2 lb. (90.8 g.).
Envelope (Handle) - 5.20 x 1.25 x 2.00 in. (13.2 x 3.2 x 5.1 cm.).
(Trigger) - 3.55 x 3.23 x 1.46 in. (9.0 x 8.2 x 3.7 cm.).
Volume (Handle) - 13.0 in.³ (174 cm.³).
(Trigger) - 16.7 in.³ (274 cm.³).
- Assembly attaches to quick attachment mounting foot on HDC bottom in the following order: (a) Trigger Assembly slides on HDC mounting foot from the camera front; (b) RCU Camera Mount Bracket base fits over bottom of Trigger Assembly; (c) Handle attachment bolt passes through RCU Bracket and Trigger Assembly into 3/8 x 16 threaded hole in HDC mount; with Handle part number toward camera lens, Handle bolt is tightened securely with bolt thumb wheel.
- The Trigger Assembly provides a spring-loaded mechanical linkage to the operate button on the camera front.
- The RCU Camera Mount Bracket attaches the lunar surface Hasselblad camera assembly to the life support system remote control unit (RCU) on the chest of the suited crewman. The bracket can be removed from the RCU easily by the crewman. The bracket provides comfortable aiming of the Hasselblad camera assembly for lunar surface operations.

- The Handle Assembly fits the gloved crewman's hand comfortably permitting easy operation of the Trigger Assembly. A section of the handle telescopes to provide additional length if required.
- The Handle and Trigger Assemblies are qualified for use in the Apollo vehicles and on the lunar surface.

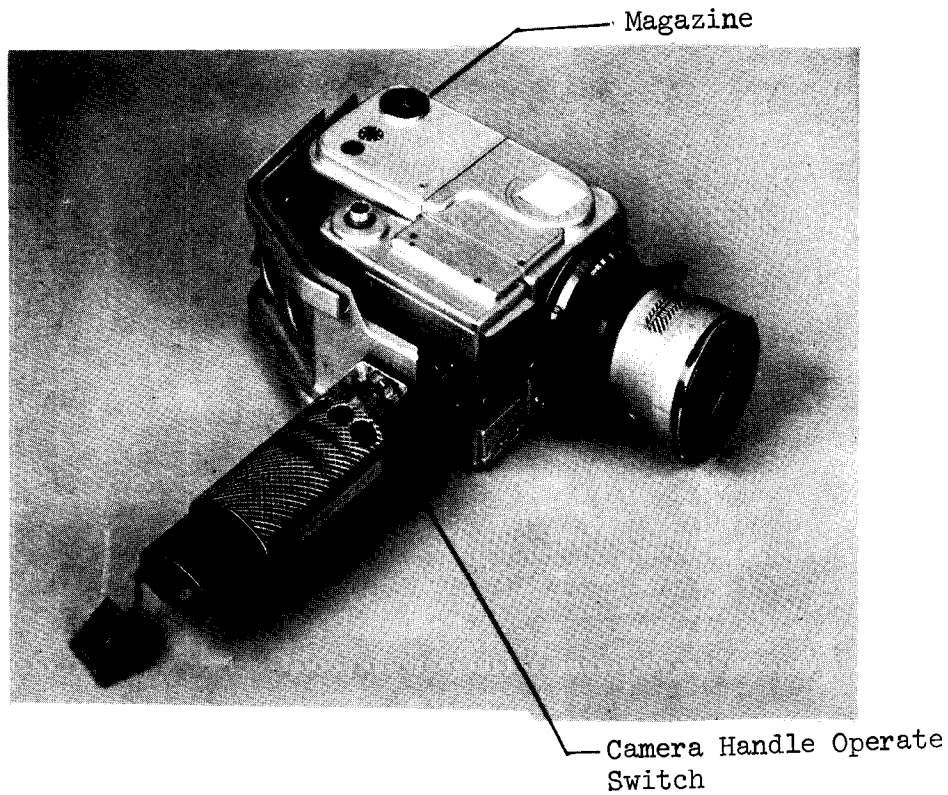

Figure 4.8-1 - Handle and Trigger Assembled on HDC

4.9 Hasselblad Electric Camera (HEC) (SEB33100102):

The Hasselblad Electric Camera (HEC) is a space modified version of the commercial 500 EL Hasselblad camera and is used for medium resolution photography from the CM during Apollo missions. The mechanical and electrical characteristics of the HEC are nearly identical to those of the HDC (see 4.1); the absence of the glass reseau plate is the most significant difference. The HEC includes an 80 mm. lens (similar to the 80 mm. lens of 4.4) as a standard part of the camera.

4.9.1 Significant Configurations:

<u>Configuration</u>	<u>Purpose</u>
-210	Apollo CM unit
-223	80 mm. lens assembly

4.9.2 Characteristics:

- Manufactured by Victor Hasselblad AB, Goteborg, Sweden, and distributed by Paillard Inc., Linden, New Jersey 07036.
- Weight (with lens and batteries) - 3.90 lbs. (1772 g.)
Envelope - 6.05 x 5.72 x 4.26 in. (15.4 x 14.5 x 10.8 cm.)
Volume - 147.2 in.³ (2415 cm.³)
- The HEC includes an 80 mm., f/2.8, lens as a standard part of the camera. This lens is identical to the 80 mm. Lens (see 4.4), P/N SEB33100261, except it is not corrected optically for the glass reseau plate of the HDC (see 4.1). This optical difference causes the HEC 80 mm. lens field-of-view to be increased to -- 37.9° x 37.9°; 51.8° diagonal. See 4.4 for all other lens characteristics.
- The HEC freely accepts the 105 mm. UV, 250 mm., and 500 mm. Lenses (see 4.10, 4.11, and 4.12) interchangeably. The 60 mm., 80 mm., and 100 mm. Lenses of the HDC system (see 4.3, 4.4, and 4.5) should not be used on the HEC.
- The HEC accepts the Film Magazine (see 4.2) containing 70 mm. film. The camera provides the locking mechanism for attachment and the drive force for film advancement. The actual film plane location is determined by the Film Magazine for the HEC system.
- The HEC motor drive provides automatic recocking of the lens shutter and film advancement after each exposure. The exposure is initiated by depressing the operate button on

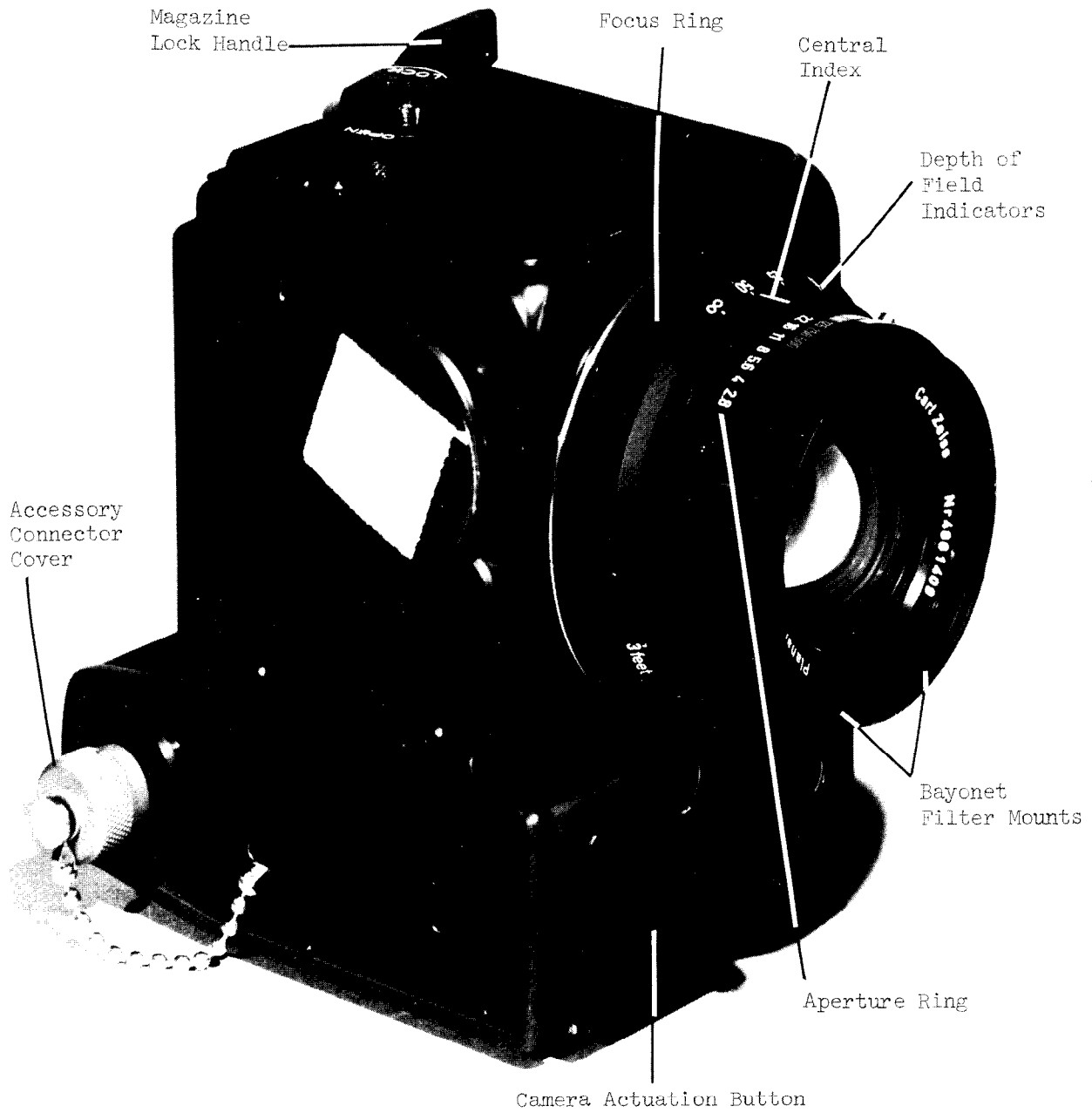

Figure 4.9-1 - Hasselblad Electric Camera, Front View

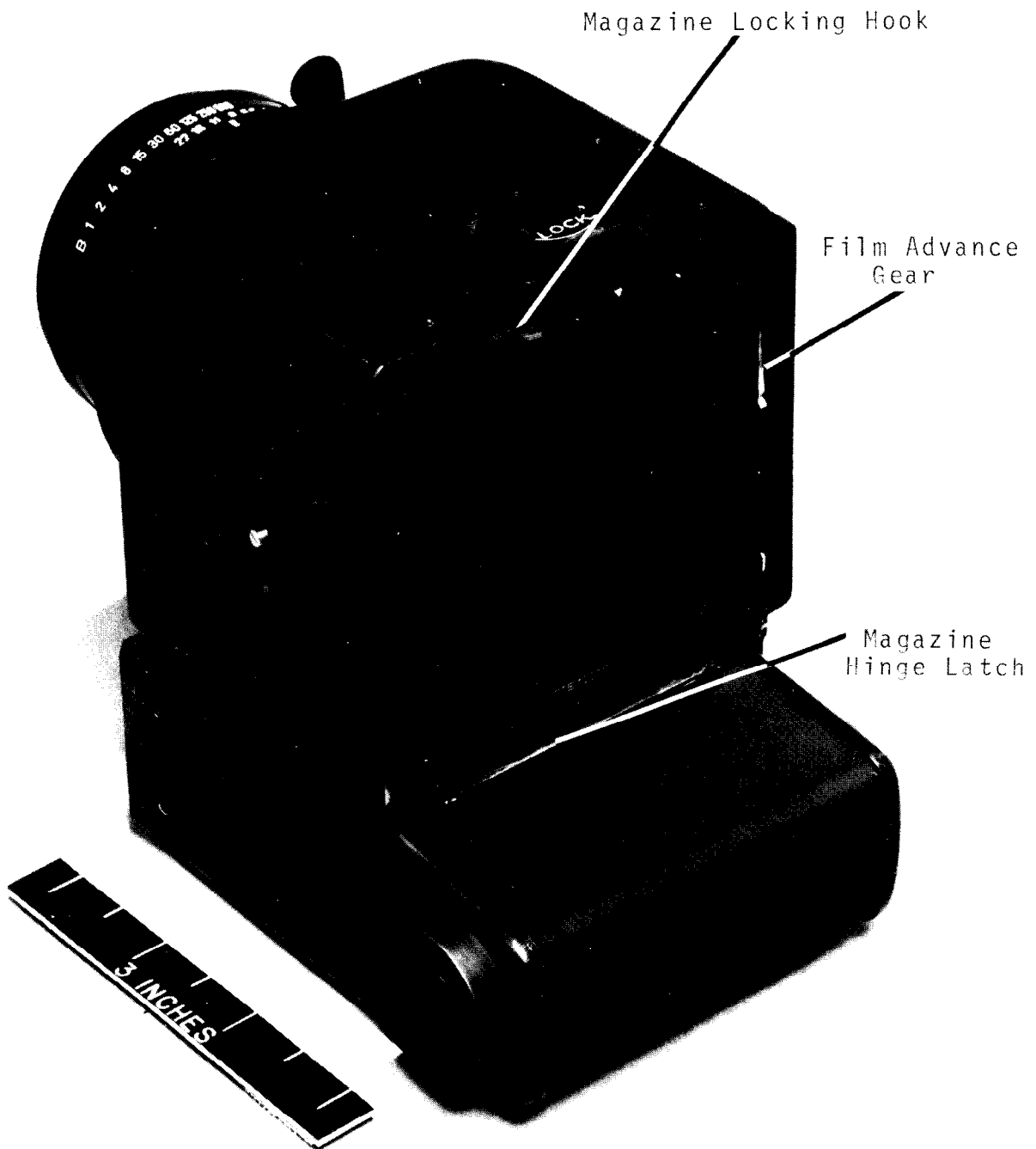

Figure 4.9-2 - Hasselblad Electric Camera, Rear View

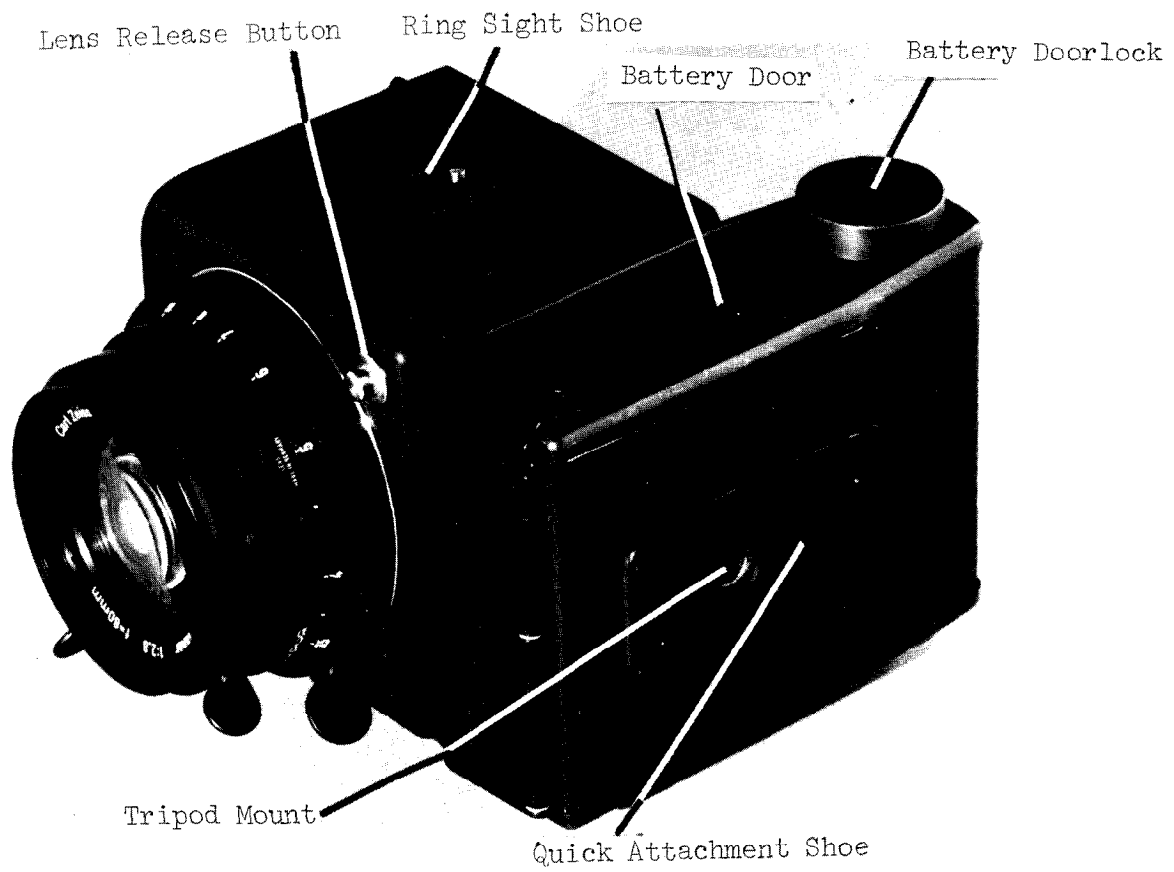

Figure 4.9-3 - Hasselblad Electric Camera, Bottom View

the camera front. Releasing the operate button activates the camera motor which automatically stops at the completion of the drive functions (approximately 1.0 second run duration).

- The HEC shutter release solenoid and drive motor are powered by two Hasselblad Batteries (see 4.6) with a capacity sufficient for approximately 3000 camera cycles. The camera may be operated with only one battery for approximately 1500 camera cycles.
- The HEC electrical circuit normally is fused with a replaceable 1.7 amp. tubular fuse. A metal slug is included as a spare. The batteries, fuse, and slug are easily accessible through the battery compartment door.
- An accessory connector (Deutsch bayonet type UR40-8-7S) is provided for electrical control of the HEC operation. The Intervalometer (see 4.14) can be connected for camera operation at a precisely repeated interval; the DAC Remote Control Cable (see 2.16) can be installed for operator initiated camera cycles from a remote position. A shutter operation signal is available in the accessory connector for use as a telemetry data source.
- Includes a quick attachment mounting foot and a $3/8$ x 16 threaded hole compatible with CM mounting brackets. Includes a shoe on the left side for attaching the Ring Sight (see 4.15) aiming device.
- The HEC is qualified for use in the Apollo vehicles.

4.10 105 mm. UV Lens (SEB33100004):

The 105 mm. UV Lens is specially designed to permit photography in the ultraviolet and the visible wavelengths from 215 to 700 n.m. The focus correction of the lens is nearly uniform throughout this spectral range; consequently, no focus changes are required when switching from visible to UV photographic tasks. Since the glass plate of the HDC (see 4.1) does not transmit ultraviolet radiation, this lens can be used only on the HEC (see 4.9).

4.10.1 Significant Configurations:

<u>Configuration</u>	<u>Purpose</u>
-301	Apollo CM unit

4.10.2 Characteristics:

- Manufactured by Carl Zeiss, Oberkochen, West Germany, and distributed by Paillard Inc., Linden, New Jersey 07036.
- Weight - 1.5 lbs. (680 g.)
Envelope - 3.34 x 3.00 Dia. in. (8.5 x 7.6 Dia. cm.)
Volume - 23.6 in.³ (387 cm.³)
- Field-of-view - 29.4° x 29.4°; 41.0° diagonal
- Focus range - 6 feet to infinity with markings for 6, 8, 10, 13, 20, 30, 50, and 100 ft. and for infinity.
- Aperture - f/4.3 through f/32 with detents at f/4.3 and at each half-stop from f/5.6 thru f/32.
- Indicators are provided immediately in front of the focus ring to show the acceptable depth-of-field (object range in focus) for any aperture/focus setting.
- Shutter speeds - the included Compur shutter has settings of B (bulb), 1, 1/2, 1/4, 1/8, 1/15, 1/30, 1/60, 1/125, 1/250, and 1/500 second with detents at each value.
- Sturdy tabs are provided on the focus, aperture, and shutter speed control rings to aid the crewman in setting adjustment.
- The optical design provides significant transmission and uniform focus throughout the 215 to 700 nm. spectral range. This lens should be used with the non-reseau HEC (see 4.9) only.

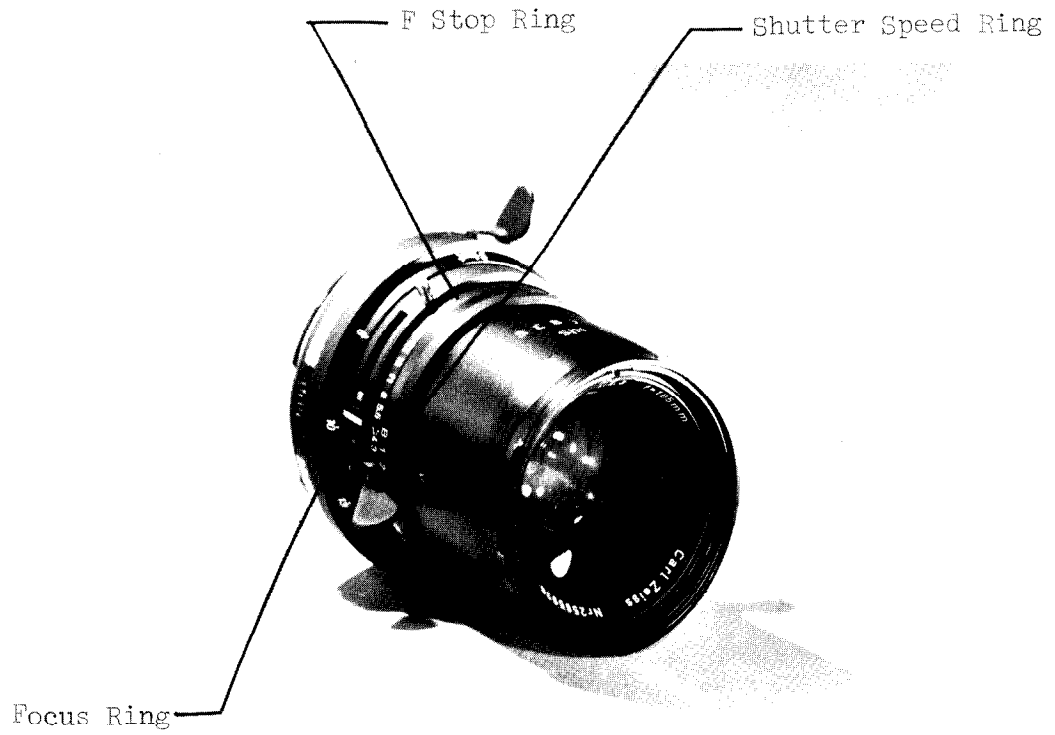

Figure 4.10-1 - 105 mm. UV Lens

- The inside and the outside bayonet filter mountings of the commercial lens are included on the lens front. Special filter assemblies have been attached to the outer mountings during Apollo experiment operations.
- The 105 mm. UV Lens is qualified for use in the Apollo vehicles.

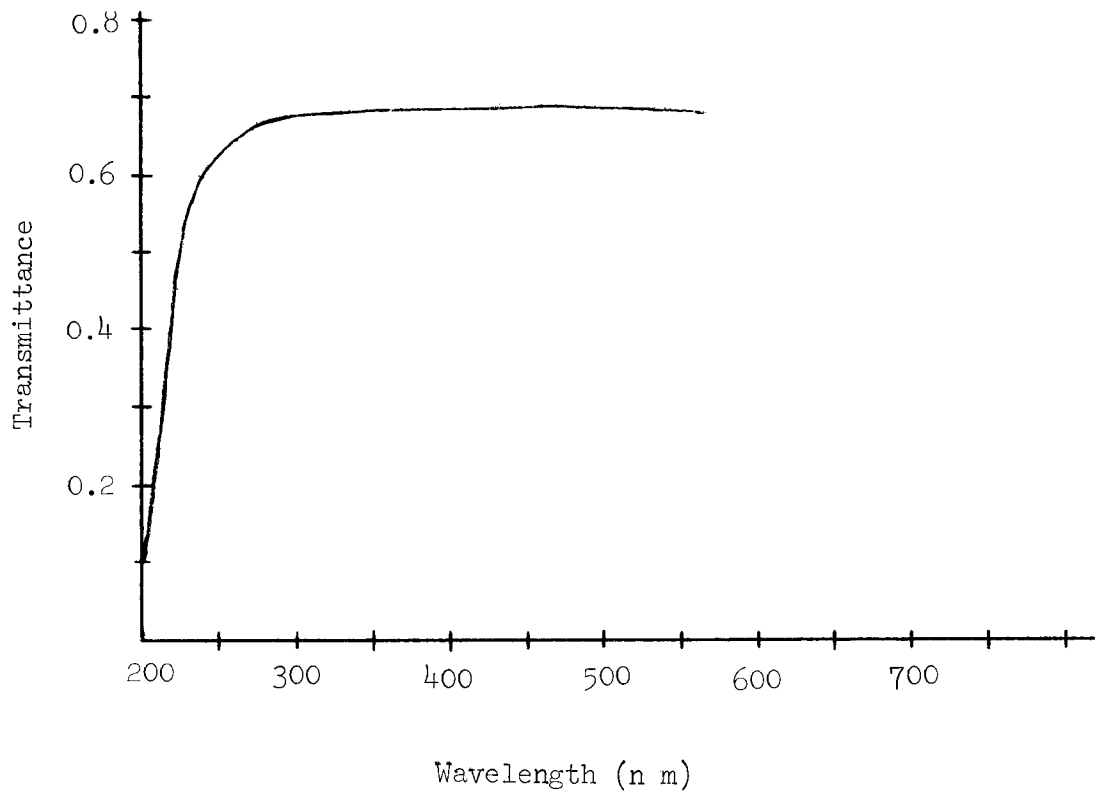

Figure 4.10-2 - Spectral Transmittance (Typical)

4.11 250 mm. Lens (SEB33100032):

The 250 mm. Lens, a modification of the commercial equivalent, is designed for use on the HEC (see 4.9) when photographing distant detail. This lens has been used throughout the Gemini and Apollo Programs for earth and lunar orbital photography.

4.11.1 Significant Configurations:

<u>Configuration</u>	<u>Purpose</u>
-201	Apollo CM unit

4.11.2 Characteristics:

- Manufactured by Carl Zeiss, Oberkochen, West Germany, and distributed by Paillard Inc., Linden, New Jersey 07036.
- Weight - 2.0 lbs. (908 g.)
Envelope - 6.29 x 3.60 Dia. in. (16.0 cm. x 9.2 Dia. cm.)
Volume - 64.0 in.³ (1050 cm.³)
- Field-of-view - 12.5 x 12.5^o; 17.6^o diagonal
- Focus range - 8.5 feet to infinity with markings for 8.5, 9, 9.5, 10, 10.5, 11, 11.5, 12, 13, 14, 15, 17, 20, 22, 25, 30, 40, 50, 70, 100, and 200 ft. and for infinity.
- Aperture - f/5.6 through f/45 with detents at each half stop.
- Indicators are provided immediately in front of the focus ring to show the acceptable depth-of-field.
- Shutter speeds - the included Compur shutter has settings of B (bulb), 1, 1/2, 1/4, 1/8, 1/15, 1/30, 1/60, 1/125, 1/250, and 1/500 second with detents at each value.
- Sturdy tabs are provided on the focus, aperture, and shutter speed control rings to aid the crewman in setting adjustment.
- The inside and the outside bayonet filter mountings of the commercial lens are included on the lens front. The inside mounts accept the Filter Assemblies (see 4.13).
- The 250 mm. Lens is qualified for use in the Apollo vehicles.

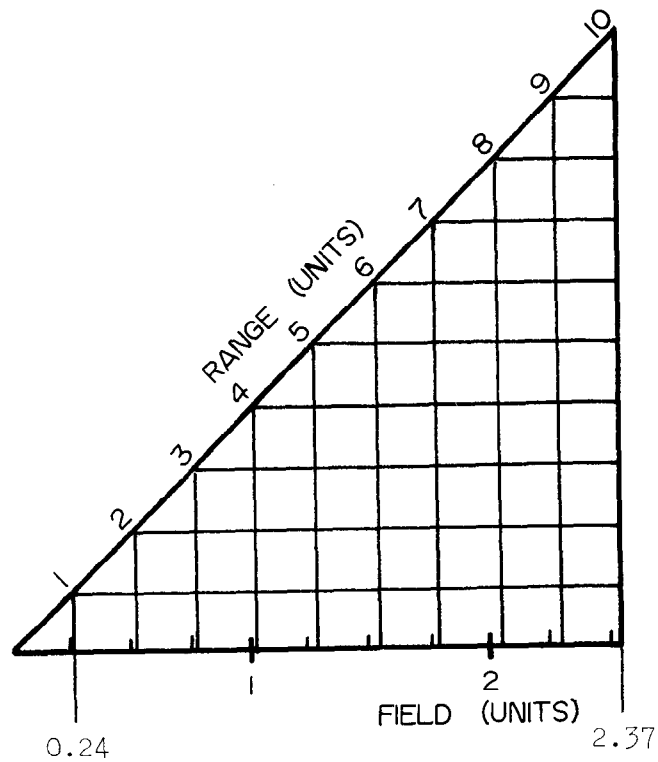
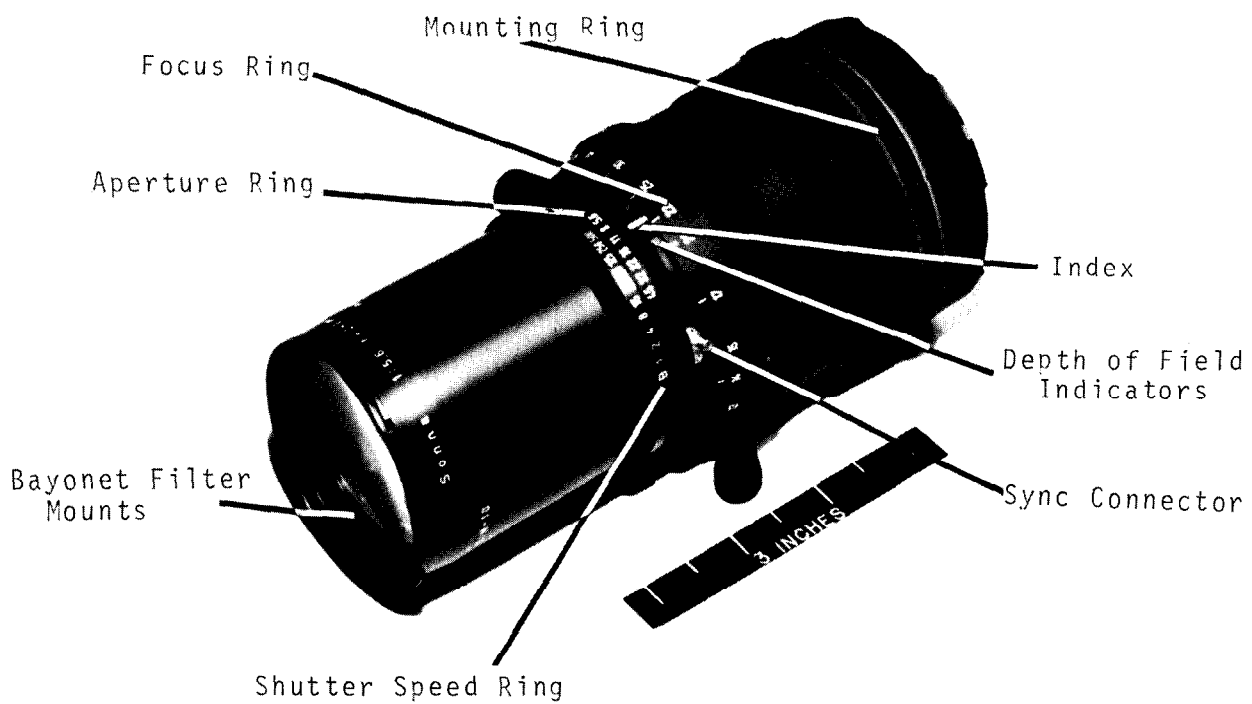

Figure 4.11-1 - 250 mm. Lens and Field-of-View Chart

4.12 500 mm. Lens (SEB33100284):

The 500 mm. Lens is the longest focal length lens available for the HEC (see 4.9) and HDC (see 4.1) systems. A modification of the commercial equivalent, this lens is designed for use with the HEC when photographing distant detail. A specially adjusted configuration has been used with the HDC on the lunar surface.

4.12.1 Significant Configurations:

<u>Configuration</u>	<u>Purpose</u>
-301	Apollo CM unit; used with HEC (see 4.9); black exterior.
-302	Apollo LM and lunar surface unit; used with -309 HDC (see 4.1); aluminum painted exterior.

4.12.2 Characteristics:

- Manufactured by Carl Zeiss, Oberkochen, West Germany, and distributed by Paillard, Inc., Linden, New Jersey 07036.
- Weight (-301) - 4.48 lbs. (2020 g.).
(-302) - 4.60 lbs. (2090 g.).
Envelope (-301) - 12.33 x 3.54 Dia. in. (31.3 x 9.0 Dia. cm.).
(-302) - 12.75 x 3.70 Dia. in. (32.4 x 9.4 Dia. cm.).
Volume (-301) - 121.3 in.³ (1988 cm.³).
(-302) - 137.1 in.³ (2245 cm.³).
- Field-of-view (-301) - 6.4° x 6.4°; 9.0° diagonal.
(-302) - 6.0° x 6.0°; 8.5° diagonal.
- Focus range (-301) - 28 feet to infinity with markings for 28, 29, 30, 32, 34, 36, 38, 40, 45, 50, 55, 60, 70, 80, 90, 100, 125, 150, 200, 300, and 600 feet and for infinity.
(-302) - focus fixed and optimized for 1.0 km. on the lunar surface.
- Aperture (-301) - f/8 through f/64 with detents at each half stop.
(-302) - f/8 through f/11 with detents at each half stop.

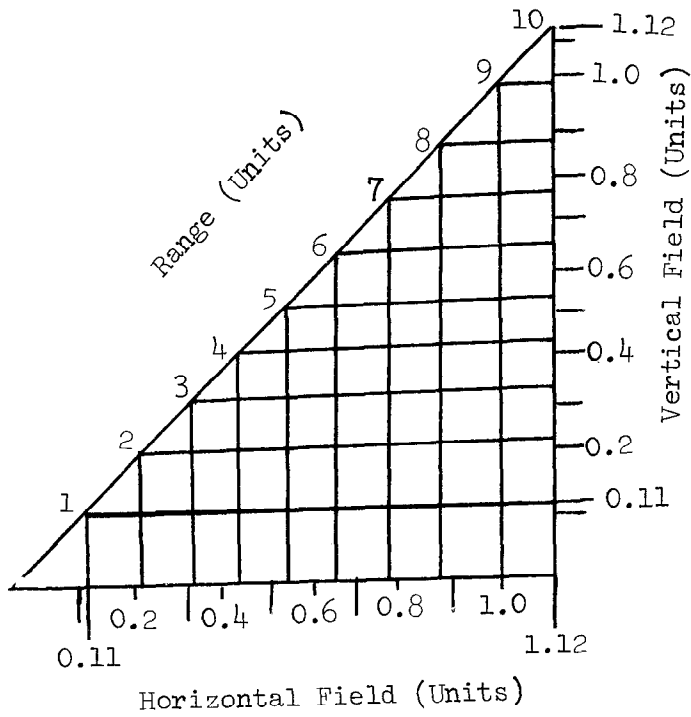
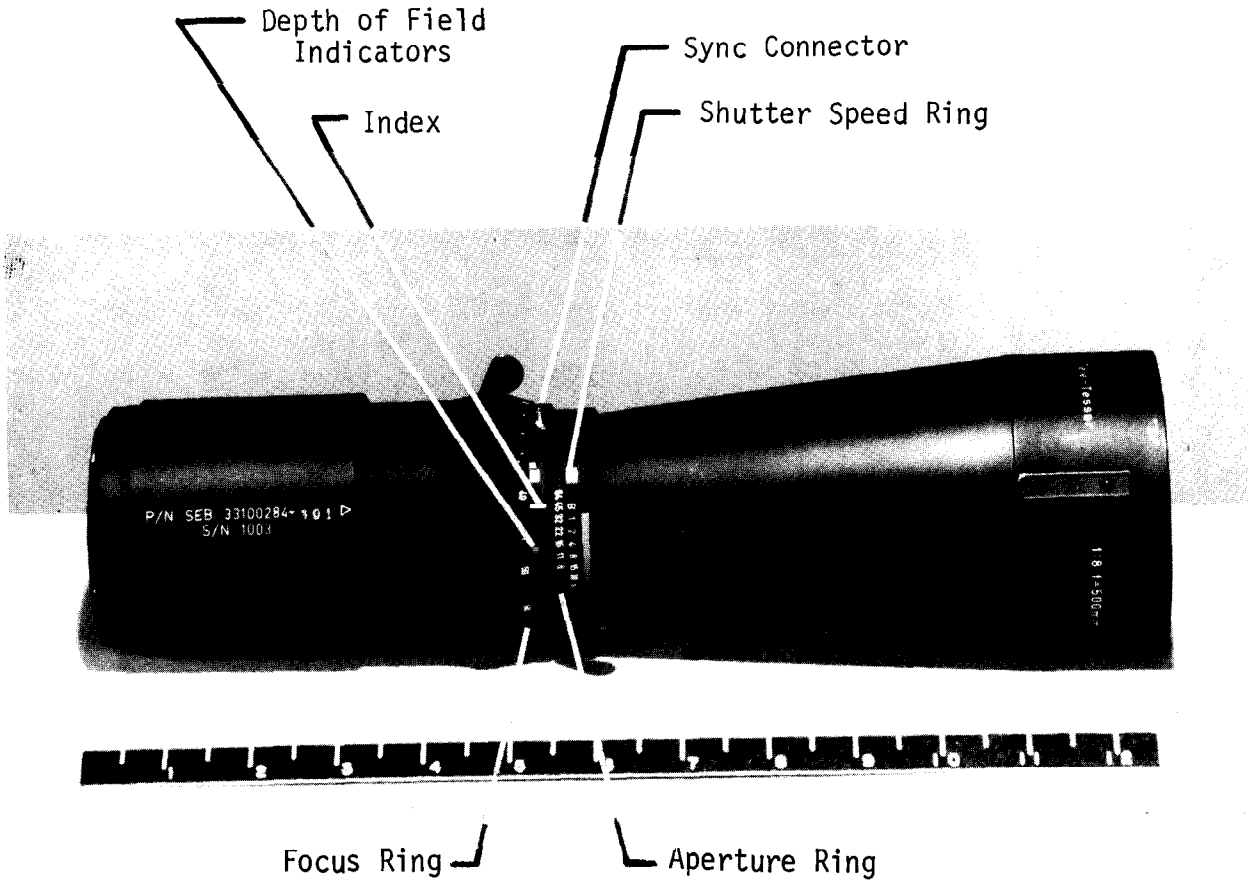

Figure 4.12-1 - 500 mm. Lens (-301) and Field-of-view Chart

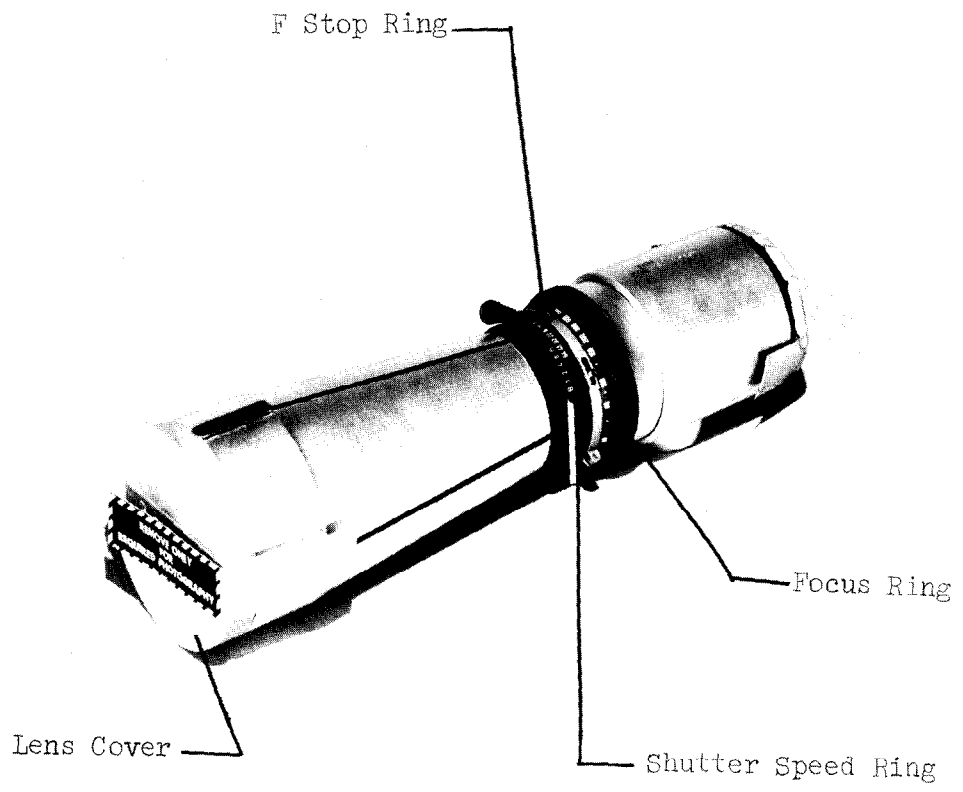

Figure 4.12-2 - Lunar Surface 500 mm. Lens (-302)

- Indicators are provided immediately in front of the focus ring to show the acceptable depth-of-field. The -302 lens provides good focus at $f/8$ from 0.5 to 14.3 km. and at $f/11$ from 0.4 km. to infinity.
- Shutter speeds - the included Compur shutter has settings of B (bulb), 1, $1/2$, $1/4$, $1/8$, $1/15$, $1/30$, $1/60$, $1/125$, $1/250$, and $1/500$ second with detents at each value. The -302 lens shutter ring is limited to the $1/125$ and $1/250$ second settings or to the $1/60$, $1/125$, and $1/250$ second settings depending on mission requirements.
- Sturdy tabs are provided on the focus, aperture, and shutter speed control rings to aid the crewman in setting adjustment.
- The -302 configuration lens includes a tape covering over the lens rear for stowage protection, a tape/metal lens front cover for dust protection, and a thermal control aluminum paint coating to moderate the temperature extremes of lunar surface operations.
- The 500 mm. lens is qualified for use in the Apollo vehicles and on the lunar surface.

4.13 Filter Assemblies (SEB33100050):

The Filter Assemblies are various glass filters mounted in a metal ring that attaches easily to the front of the 80 mm. Lens (see 4.4 and 4.9), the 100 mm. Lens (see 4.5), the 105 mm. UV Lens (see 4.10), or the 250 mm. Lens (see 4.11). These assemblies have been used during the Gemini and Apollo Programs to provide selected filtration for operational and experimental photography.

4.13.1 Significant Configurations;

<u>Configuration</u>	<u>Purpose</u>
-201	Haze; Corning, 0.52 UV.
-202	Orange; Tiffen, Photar 15.
-204	Red; Tiffen, Photar 25A or Hasselblad, Red #50059.
-206	Haze; Tiffen, Photar 2A.
-207	Green; Tiffen, Photar 58B.
-208	IR; Tiffen, Photar 89B.
-209	Yellow (light balancing); Kodak 81A.
-210	Blue (light balancing); Kodak 82C.
-211	Blue (light balancing); Tiffen B-3.
-212	Deep Blue; Kodak 47B.
-213	Deep Red; Kodak 29 + 0.6 ND.
-214	IR; Kodak 87C.
-215	Deep Red; Tiffen, Photar 29.

4.13.2 Characteristics:

Filter materials manufactured as indicated by Corning Glass Works, Corning, New York 14830; Victor Hasselblad AB, Goteborg, Sweden; Eastman Kodak Co., Rochester, New York 14650; Tiffen Optical Col, Roslyn Heights, L.I., New York 11577.

- Weight - 0.10 lb. (45.4 g.).
Envelope - 0.23 x 2.33 Dia. in. (0.59 x 5.90 Dia. cm.).
Volume - 0.97 in.³ (15.9 cm.³).
- The Filter Assemblies bayonet mount onto the inside mounts on each lens front (see 4.4, 4.5, 4.9, 4.10, and 4.11). The mounting is identical to that of the Hasselblad Series 50 commercial filters.
- The Filter Assemblies are qualified for use in the Gemini and Apollo vehicles.

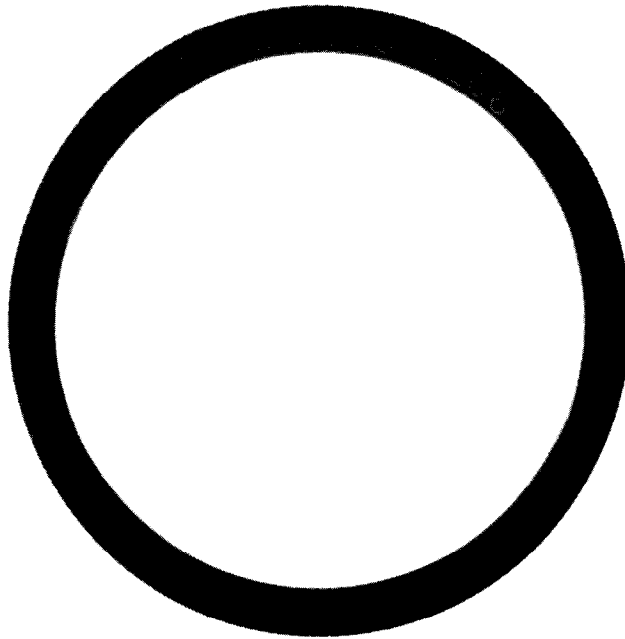

Figure 4.13-1 - A Typical Filter Assembly

4.14 Intervalometer (SEB33100043):

The Intervalometer is a solid-state electronic device used to provide automatic sequencing of the HDC (see 4.1) and HEC (see 4.9) systems. The primary use of this accessory has been during Apollo to obtain overlapping strip photography of the lunar surface from orbit.

4.14.1 Significant Configurations:

<u>Configuration</u>	<u>Purpose</u>
-301	Apollo 20-second interval unit.
-302	Apollo 8-second interval unit.

4.14.2 Characteristics:

- Manufactured by J. A. Maurer, Inc., Long Island City, New York 11101.
- Weight - 0.25 lb. (114 g.).
Envelope (w/o cable) - 2.50 x 2.50 x 1.12 in.
(6.35 x 6.35 x 2.95 cm.)
Volume (w/o cable) - 7.0 in.³ (115 cm.³).
- The Intervalometer actuates the camera (see 4.1 or 4.9) immediately upon being turned "ON" and every 20 seconds (-301) or 8 seconds (-302) thereafter until turned "OFF" or until the film supply is depleted. The repeatability of the interval is + 1.0 second after the first interval. Camera shutter speeds of 1/15 to 1/500 second are permitted.
- The Intervalometer connects to the accessory connector of the HDC or HEC with a 12.0 ± 0.5 in. (30.5 ± 1.3 cm.) cable. The camera end of the cable has a Deutsch-type UR46-8-7P bayonet connector.
- The Intervalometer is powered by the camera batteries and consumes no more than 50 ma while "ON".
- The Intervalometer is qualified for use in the Apollo vehicles.

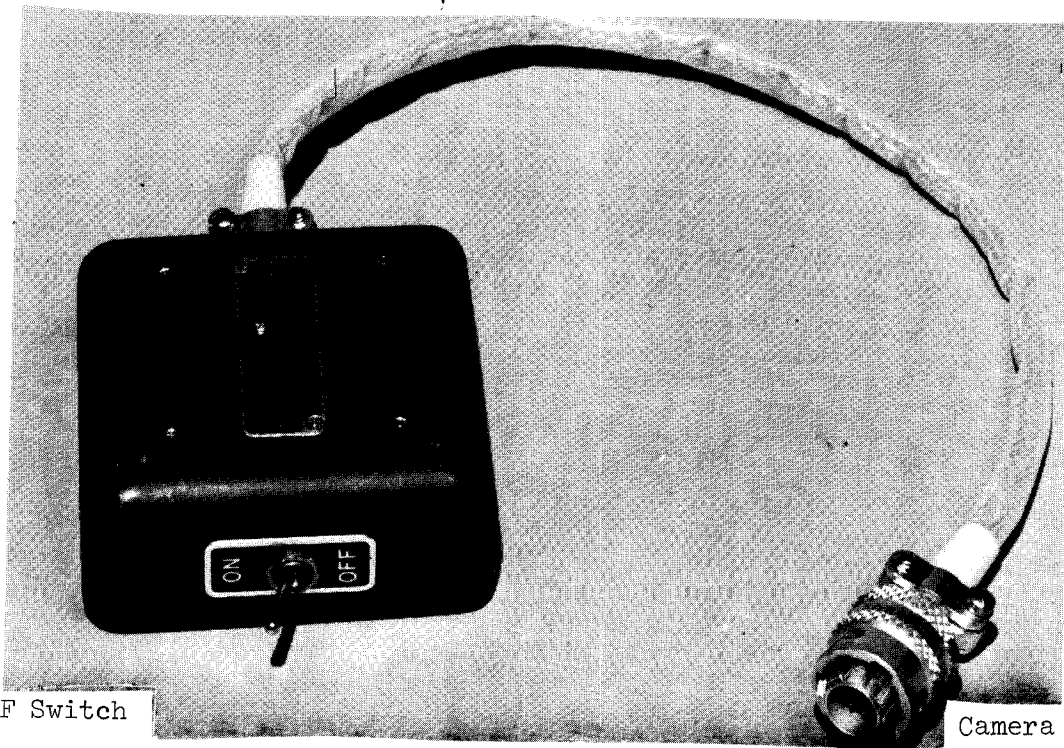

ON/OFF Switch

Camera Connector

Figure 4.14-1 - 20-Second Intervalometer (-301)

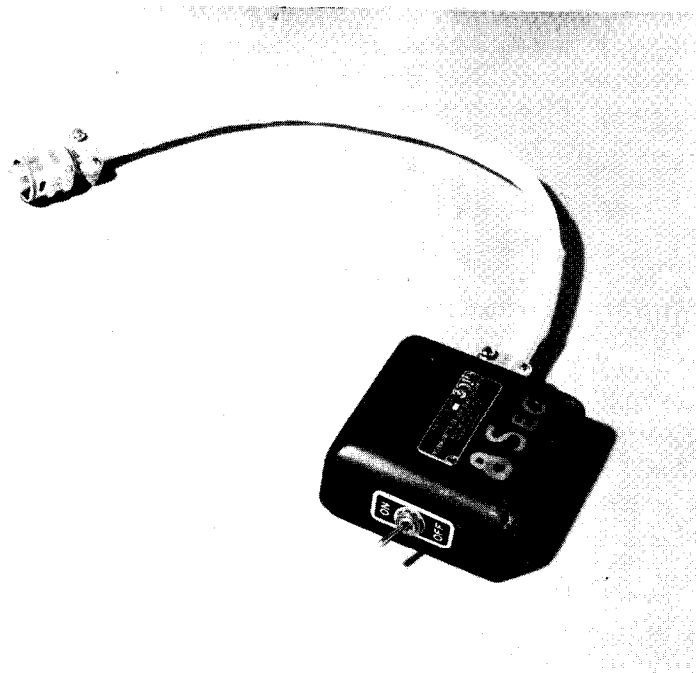

Figure 4.14-2 - 8-Second Intervalometer (-302)

4.14-2

4.15 Ring Sight (SEB33100031):

The Ring Sight is a small removable aiming device that can be used on the DAC (see 2.1), the HDC (see 4.1), or the HEC (see 4.9). Light interference in the Ring Sight superimposes concentric light and dark rings on the normal scene view. The common center of the rings corresponds with the center of the camera/lens view. Use of the Ring Sight is recommended when precision camera aiming is desired or is necessitated by the use of long focal length lenses.

4.15.1 Significant Configurations:

<u>Configuration</u>	<u>Purpose</u>
-204	Gemini, Apollo, and Skylab unit.

4.15.2 Characteristics:

- Assembly manufactured by Technical Services Division, NASA MSC, Houston, Texas 77058.
- Weight - 0.08 lb. (36.4 g.).
Envelope - 1.20 x 1.20 x 0.64 in. (3.0 x 3.0 x 1.6 cm.).
Volume - 0.92 in.³ (15.1 cm.³).
- Optical ring sight material is manufactured by the Polaroid Corp., Cambridge, Massachusetts 02139. The angular diameters of the central three rings are $4^{\circ} \pm 1^{\circ}$, $7.5^{\circ} \pm 1^{\circ}$, and $10^{\circ} \pm 1^{\circ}$. These three rings are visible if the observer's eye is less than 4.5 inches (11.4 cm.) away from either surface of the sight.
- Ring Sight slides into shoe on camera for attachment.
- The Ring Sight is qualified for use in the Gemini, Apollo, and Skylab vehicles and on the lunar surface.

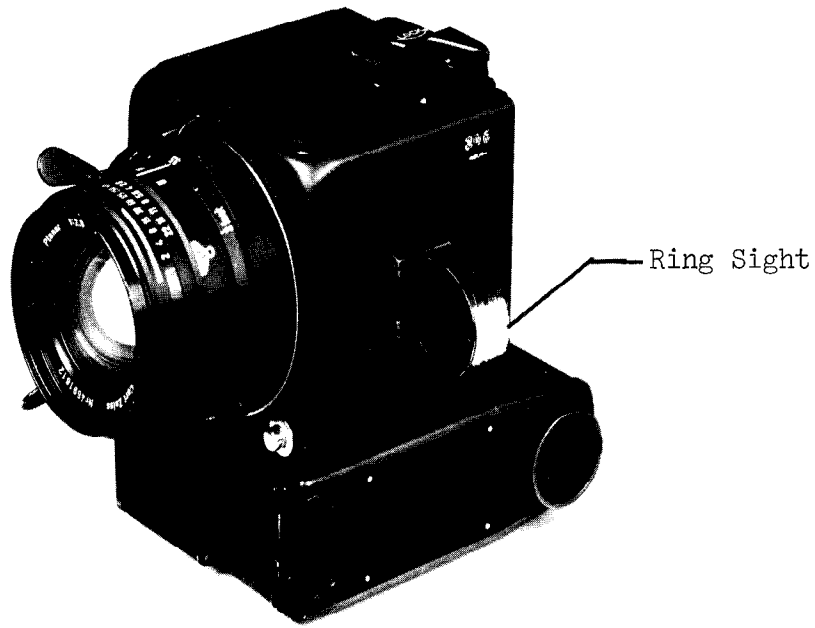
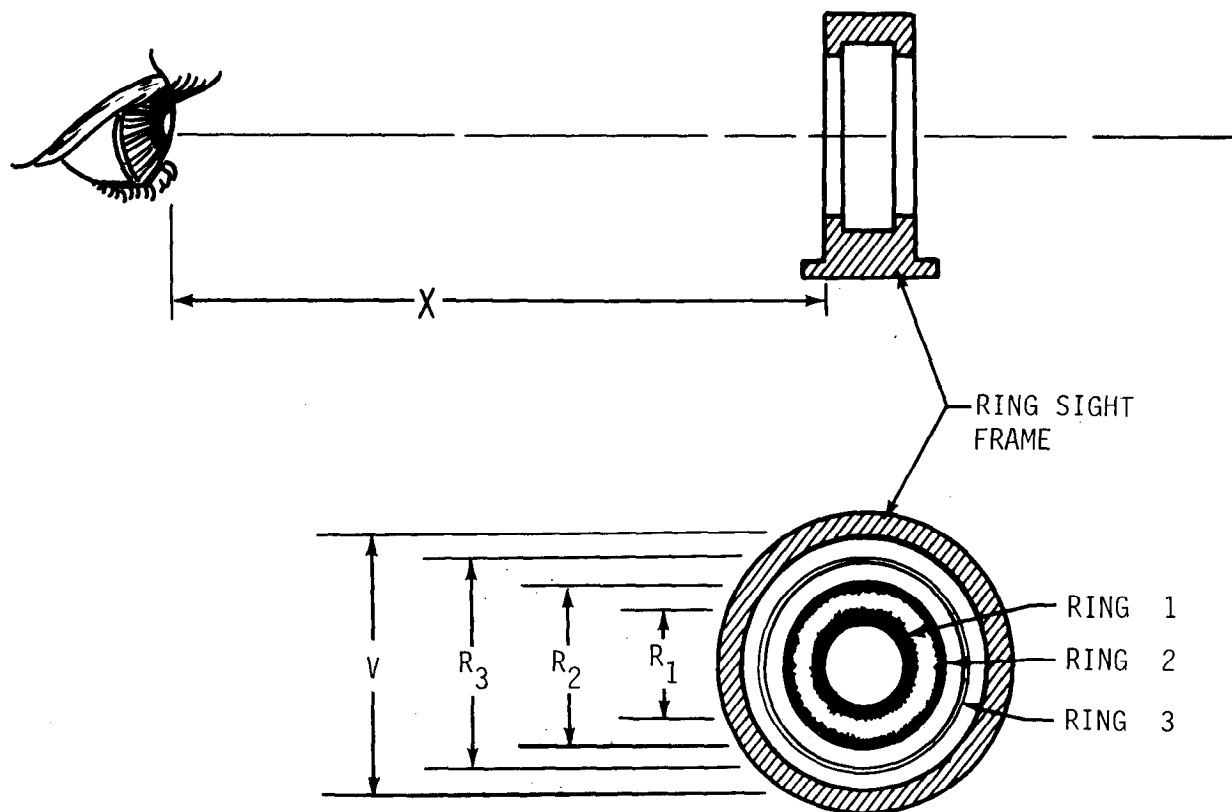
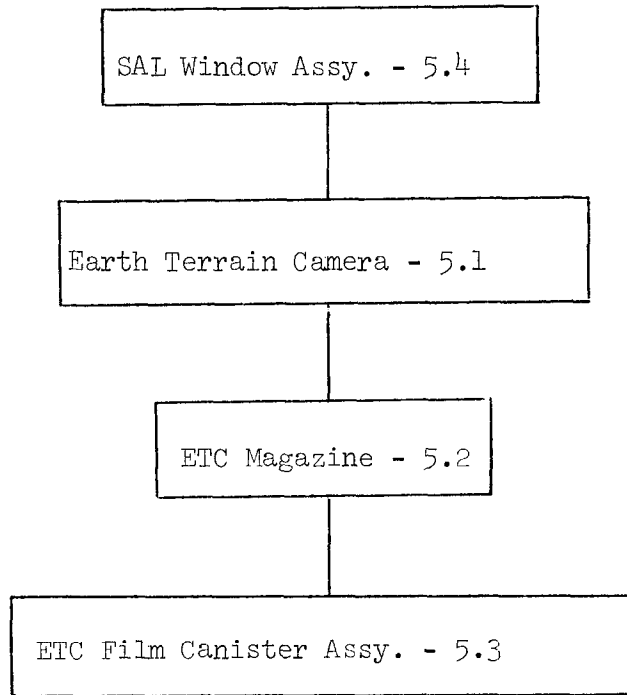

Figure 4.15-1 - Ring Sight Installed on HEC



X (IN)	R ₁	R ₂	R ₃	FIELD OF VIEW (V)
0	4°	7.5°	10°	53°
4.5	4°	7.5°	10°	10°

Figure 4.15-2 - Ring Sight Viewing Characteristics



5.1 Earth Terrain Camera (ETC) (SEC33100786):

The Earth Terrain Camera (ETC) is the major system component and includes an outer lens cone/mount assembly, the lens cone itself comprising the lens and the camera electronics, a control box, and the camera body which houses the ETC Magazine (see 5.2). The ETC is designed to obtain high resolution photographs of the earth during the performance of Skylab Experiment S190(B). The functional capabilities of the ETC permit automatic operation for overlapping topographic coverage and manual operation for single photographs of selected scenes.

5.1.1 Significant Configurations:

<u>Configuration</u>	<u>Purpose</u>
-301	Skylab Experiment S190(B) unit.

5.1.2 Characteristics:

- Manufactured by Actron Industries, Inc., Monrovia, California 91016.
- Weight (with ETC Magazine, without film - launch configuration) - 77 lbs. (35.0 kg.).
(with film) - 80 lbs. (36.4 kg.).
- Envelope - 28.31 x 11.25 x 13.45 in. (718 x 268 x 342 cm.).
Volume - 4280 in.³ (70,000 cm.³).
- Electrical power requirements - supplied to the ETC through a cable from the spacecraft. AC Power - 115 vac, 400 Hz, 3 phase is for all camera drive motors - shutter, film transport, and forward motion compensation (FMC). DC Power - +28 $\frac{+2}{-5}$ is for camera control circuits and relay operation. Separate returns are provided for the AC and the DC circuits. The camera power ON/OFF switch is located on the camera control box.
- Film format - 4.5 x 4.5 in. (114 x 114 mm.) with the use of a 0.75 x 0.75 in. (9 x 9 mm) area at one format corner for data recording.
- Lens type - color corrected, f/4.0, 18 inches (457 mm.) focal length.
Field-of-view - 14.2° x 14.2°; 20.0° diagonal; for 235 n. mi. altitude - 58.7 x 58.7 n. mi.
System resolution - Film S0242 3443 3400 3414
AWAR - (1000;1 contrast) 100 44 75 180 1/mm
AWAR - (2:1 contrast) 65 25 50 100 1/mm

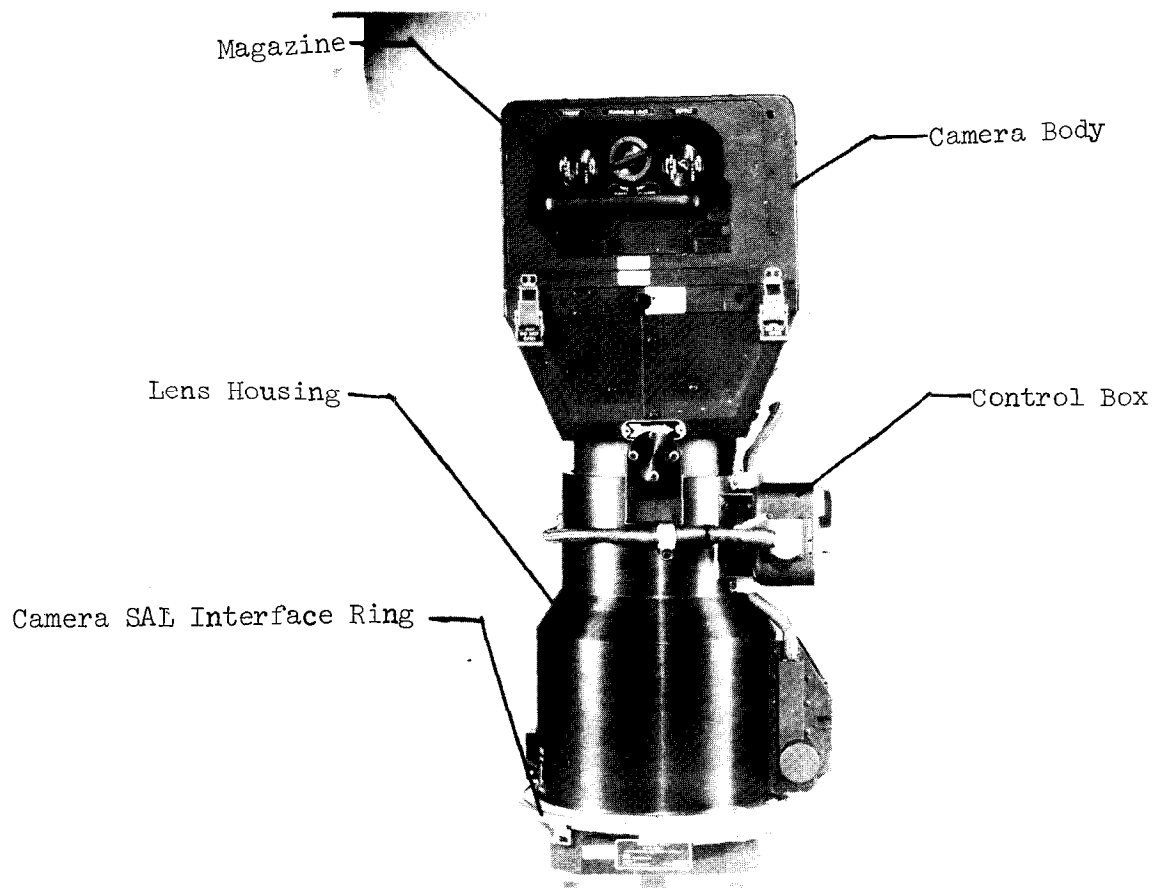

Figure 5.1-1 - Earth Terrain Camera Assembly, Front View

- Shutter type - bidirectional focal plane. The shutter speeds of $1/100 \pm 0.001$ second, $1/200 \pm 0.0005$ second, and $1/500 \pm 0.0002$ second are settable on the camera control box.
- Camera modes of single frame and of automatic sequencing operation are provided. The mode selection switch and the single frame button are located on the camera control box. When the mode selector is placed to the AUTO position, the camera cycles at the selected rate until the mode selector is placed to STBY (standby). The automatic mode cycling rate (0 to 25 frames per minute) is set by the camera operator with the FRAMES/MIN knob on the control box.
- Forward Motion Compensation (FMC) is accomplished by rocking the camera forward along the line of flight on the pivots of the outer lens/cone mount assembly. The FMC rate (0.0 to 25.0 mr/sec.) is set by the camera operator with the MR/SEC knob on the control box.
- Time data (clock with second hand and day count) are optically projected into the 9 x 9 mm. data block in the film format during the actual exposure sequence. The DATA BLOCK EXPOSURE CONTROL selector switch, located on the lens cone adjacent to the ETC Magazine interface, provides four data exposure levels to accommodate various film sensitivities as follows:

<u>Switch Position</u>	<u>Film Type</u>
1	EK 3400
2	EK 3443
3	EK 3414
4	EK S0242

- The control box is mounted to the outer lens/cone mount assembly and provides a compact grouping of the following controls and indicators:

PWR-ON/OFF Switch - master power control for ETC.

POWER ON Indicator - illuminates (green) when ETC main power relay energized.

MODE - AUTO/STBY/SINGLE Switch - for selection of ETC operation mode.

SINGLE FRAME Button - depressed for each single photograph when ETC in SINGLE mode.

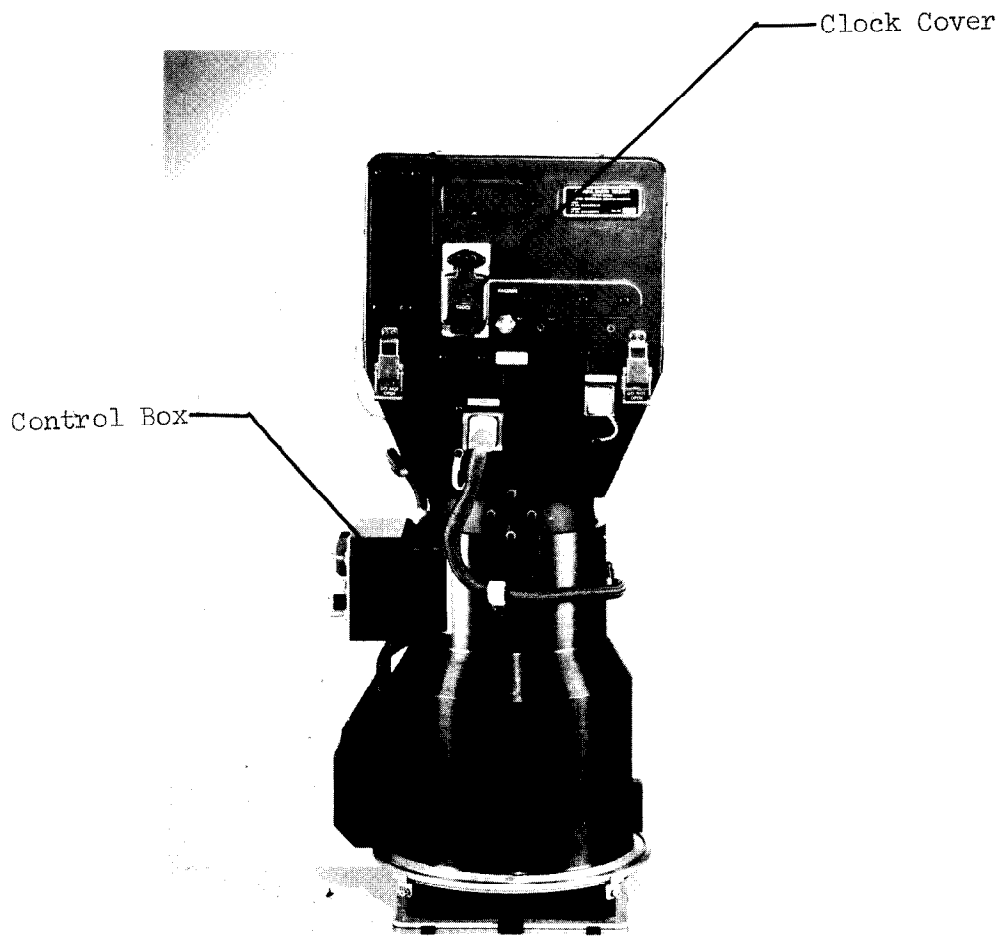

Figure 5.1-2 - Earth Terrain Camera Assembly, Rear View

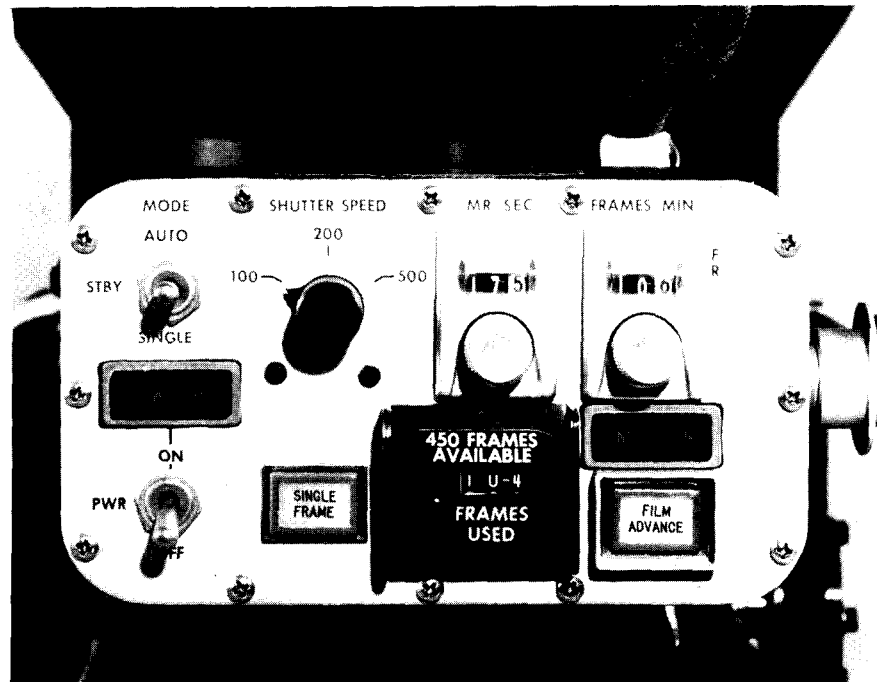

Figure 5.1-3 - ETC Control Box Face

SHUTTER SPEED - 100, 200, 500 Selector - setting can be changed at any time.

MR/SEC Knob and Dial - selects and displays FMC rate.

FRAMES/MIN Knob and Dial - selects and displays automatic mode cycling rate.

FRAMES USED Indicator - increments by one for each shutter cycle. Incorporates a reset button for returning counter to 000.

END OF FILM Indicator - illuminates (white) when film is expended, if PWR-ON.

FILM ADVANCE Button - provides fast advance (approximately 2 feet per second) of unexposed film as long as button is depressed and PWR-ON. ETC shutter is disabled during fast film advance.

- The ETC body incorporates the shutter drive and curtain, the data block clock and illuminators, a camera life cycle counter, and a vacuum connection between ETC and ETC Magazine (see 5.2). Each body has two magazines assigned by serial number. All magazines are interchangeable between ETC bodies; however, better image quality is attained when the specified magazines are used with the body. The body is positioned on the lens cone by two guide pins and is secured by four latches. Body assemblies with assigned magazines may be exchanged with any lens cone.
- The outer lens cone/mount assembly attaches to the back of the SAL Window Assembly (see 5.4) for ETC operation from the OWS. Secure attachment is provided by the Marman clamp of the SAL Window Assembly.
- For handling and stowage, the ETC lens front is protected by an included lens cover. This lens cover must be removed prior to attachment of the ETC to the SAL Window Assembly.
- Spectral filters can be attached to the lens front as required by the experiment operations. The filter must be installed prior to attachment of the ETC to the SAL Window Assembly.
- The ETC is qualified for use in the Skylab OWS.

5.2 ETC Magazine (SEC33100787):

The ETC Magazine houses and transports the film during ETC operation. With its cover in place, the magazine is light-tight and provides film protection during magazine installation, removal, and storage. The crewman can remove and replace the film upon depletion of the supply spool.

5.2.1 Significant Configurations:

<u>Configuration</u>	<u>Purpose</u>
-301	Skylab Experiment S190(B) unit.

5.2.2 Characteristics:

- Manufactured by Actron Industries, Inc., Monrovia, California 91016.
- Weight (w/o film) - 9.5 lbs. (4.3 kg.).
Envelope - 10.31 x 8.30 x 6.38 in. (26.2 x 21.1 x 16.2 cm.).
Volume - 547 in.³ (8950 cm.³).
- The magazine capacity is 200 feet (50.8 m.) of 5 inch (12.7 cm.) wide thin-base film (2.5 mil, 64 μm). This capacity provides approximately 456 usable frames.
- The magazine can be unloaded and loaded by the crewman. Darkness is required for certain portions of these operations to keep from fogging the film. A film loading diagram is printed on the back of the magazine housing.
- The ETC Magazine installs and locks into the body of the ETC (see 5.1). An interlock automatically connects the magazine circuitry to the ETC electrical power upon installation and removes power when the magazine is loosened or removed. The two magazines furnished with each ETC are specifically adjusted to the camera to ensure highest image quality.
- A vacuum regulator and vacuum slots in the platen provide film flattening during the exposure sequence. The vacuum is supplied by a vent to space connected with a hose to the port on the back of the ETC body.
- Fiducial marks and reseau points are provided by notches in and precision holes around the format mask of the magazine face.

- The ETC Magazine is qualified for use in the Skylab OWS.

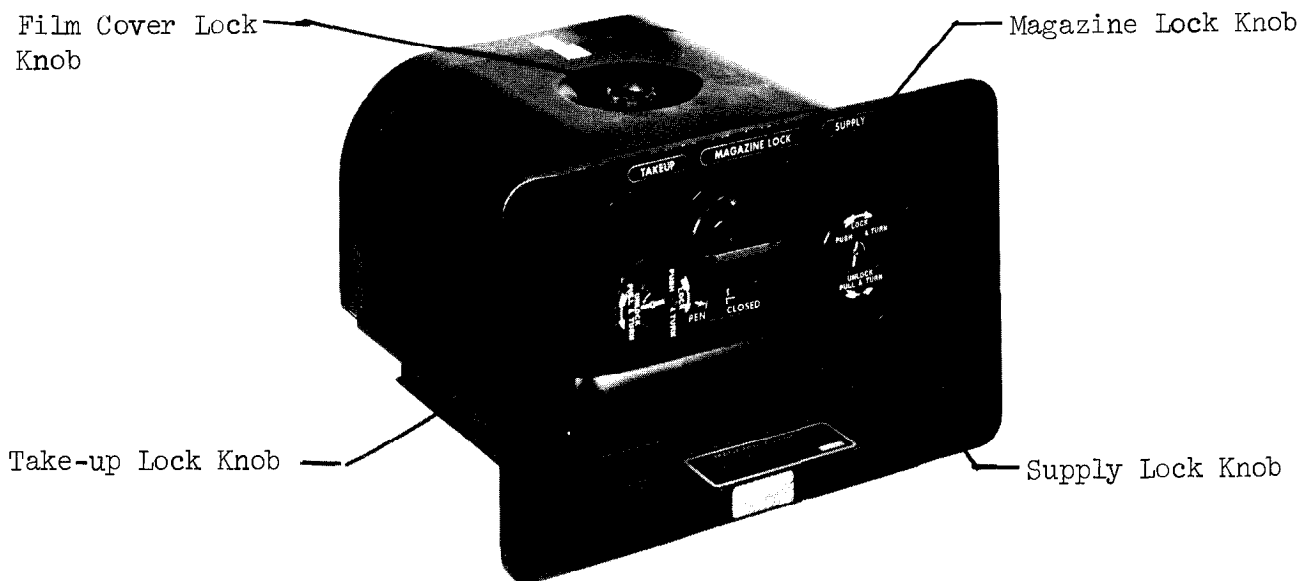

Figure 5.2-1 - ETC Magazine, Front View

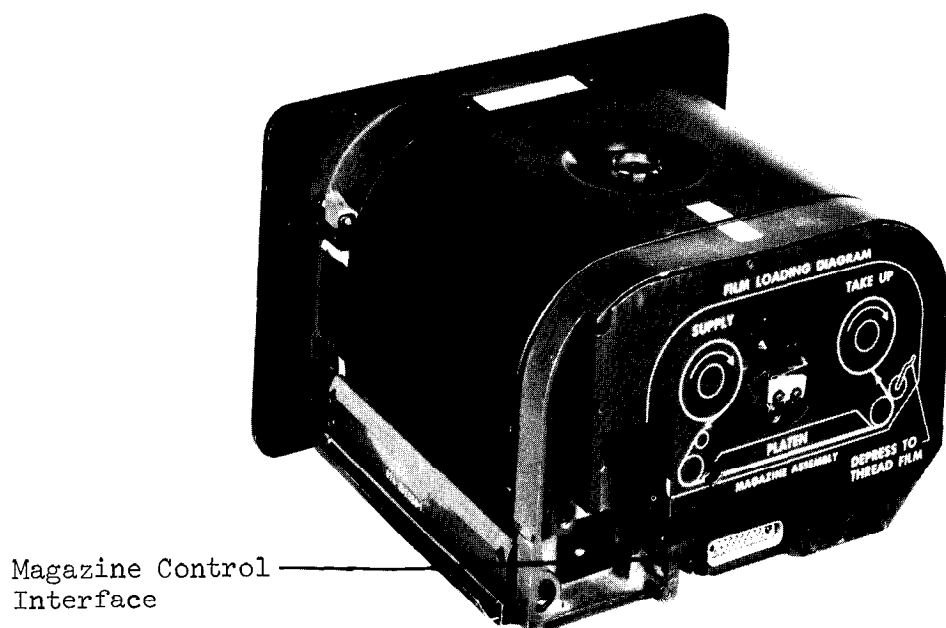

Figure 5.2-2 - ETC Magazine, Rear View

5.3 ETC Film Canister Assembly (SEC33100886):

The ETC Film Canister Assembly includes the ETC film and spool, a light-tight plastic can and lid, and a Beta fabric bag. The assembly provides protection for the ETC film during handling and stowage outside of the ETC Magazine (see 5.2).

5.3.1 Significant Configurations:

<u>Configuration</u>	<u>Purpose</u>
-301	Complete Assy. for Skylab Exp. S190(B).
SEB33100401-301	Plastic film can and lid enclosing ETC film spool.
SEB33100404-302	Beta fabric bag to enclose film can.

5.3.2 Characteristics:

- The ETC Film Canister Assy. is configured by Flight Crew Integration Division, NASA, MSC, Houston, Texas 77058.
- Weight (w/film) - 2.6 lbs. (1180 g.)
Envelope - 5.5 x 5.0 Dia. in. (14.0 x 12.7 Dia. cm.)
Volume - 108 in.³ (1770 cm.³)
- The film and spool slide freely in and out of the plastic film can when the lid is removed. The lid, attached loosely to the can by a tape hinge, snap-seal attaches to the can lip to form a light-tight enclosure for the film. The can and lid are Kodak commercial 5-inch film containers, Code 3002.
- The fabric bag provides flammability protection for the plastic film can. A draw-string closure is incorporated in the bag.
- The ETC Film Canister Assembly is qualified for use in the Skylab vehicles.

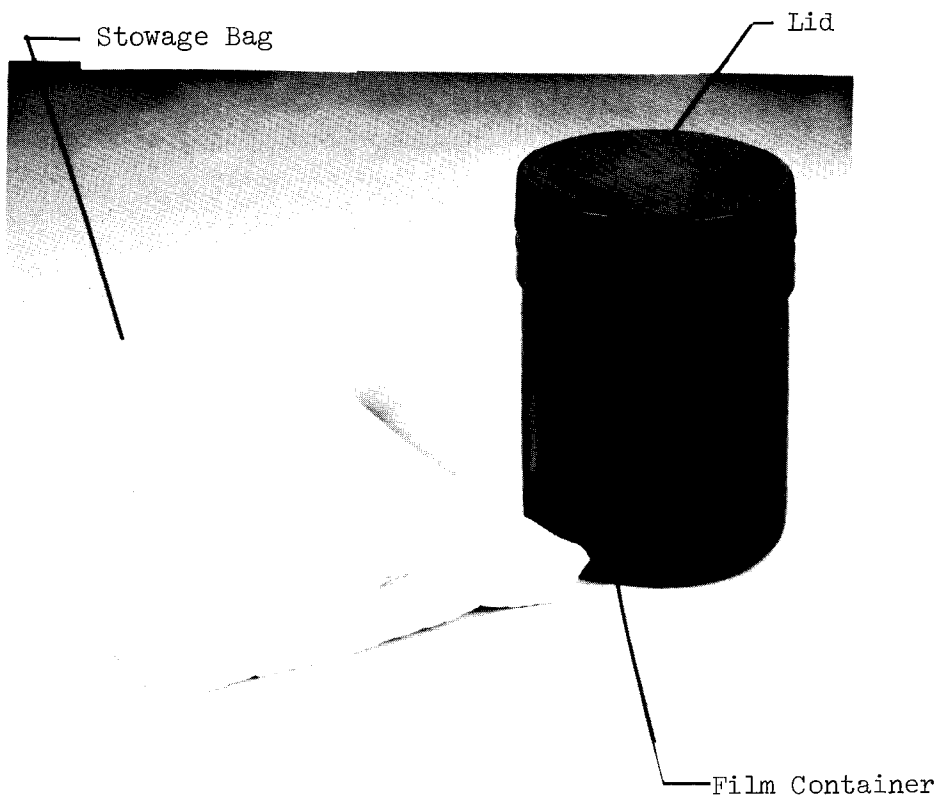

Figure 5.3-1 - ETC Film Canister Assembly

5.4 SAL Window Assembly (SEC33100788):

The SAL Window Assembly provides the interface between the Skylab OWS anti-solar Scientific Airlock (SAL) and the ETC (see 5.1). The assembly incorporates a precision optical window that is matched to the ETC lens optics and maintains the pressure integrity of the SAL.

5.4.1 Significant Configurations:

<u>Configuration</u>	<u>Purpose</u>
-301	Skylab Exp. S190(B) unit

5.4.2 Characteristics:

- Manufactured by Actron Industries, Inc., Monrovia, California 91016.
- Weight (with covers) - 12.1 lbs. (550 g.)
Envelope - 11.65 x 12.32 x 3.00 in. (29.6 x 31.3 x 7.6 cm.)
Volume - 430 in.³ (7050 cm.³)
- The front (square) side of the Window Assembly installs in the interface flange of the -Z (anti-solar) SAL. The back (round) side of the Window Assy. attaches to the ETC outer lens cone/mount assembly by means of a toggle latch ring (Marman) clamp incorporated on the Window Assy.
- Protective metal covers are attached to the front and the back interface surfaces of the Window Assy. during handling and stowage. The front cover is secured with two self-contained spring latches. The back cover is secured with the Marman clamp of the Window Assy.
- The precision optical window is incorporated just interior to the back surface of the Window Assy.
- The SAL Window Assembly is qualified for use in the Skylab OWS.

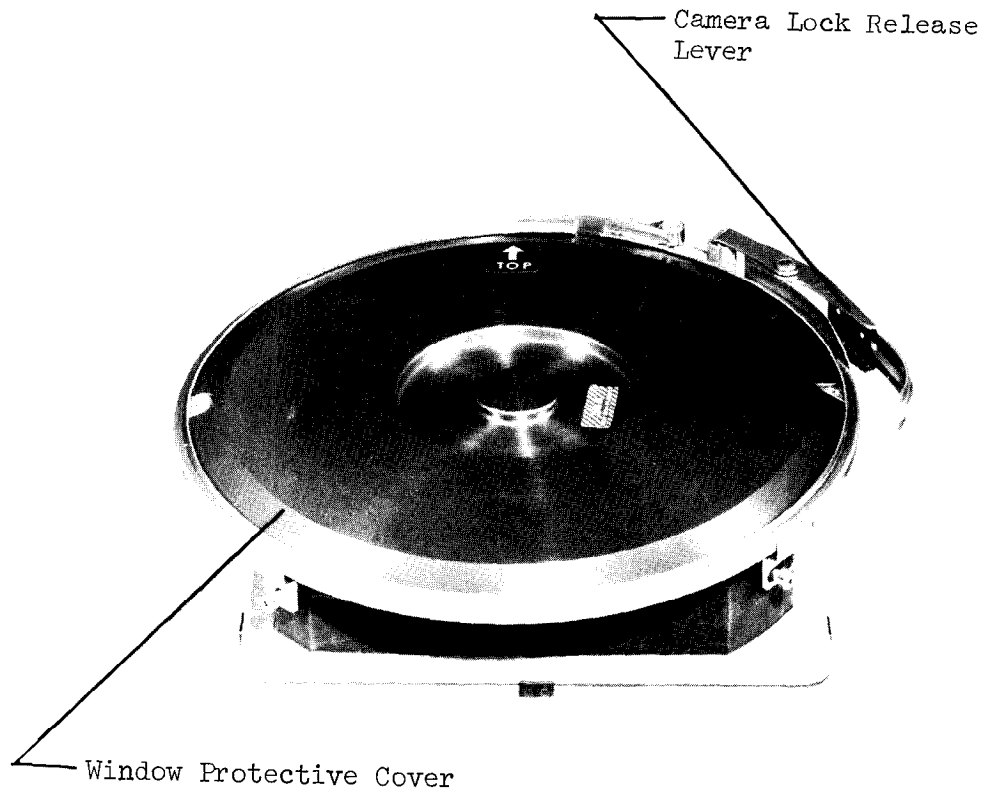

Figure 5.4-1 - SAL Window Assembly

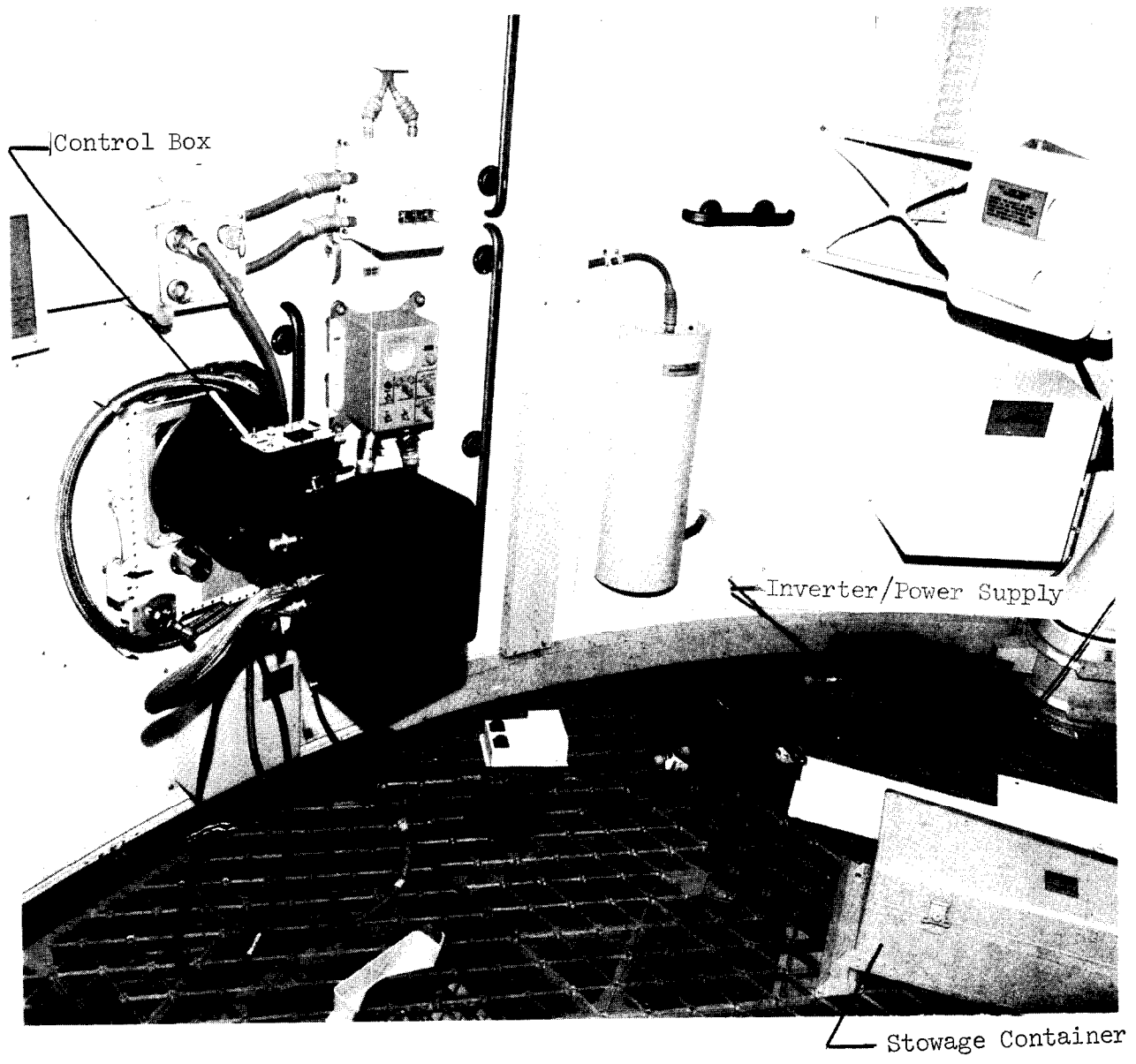
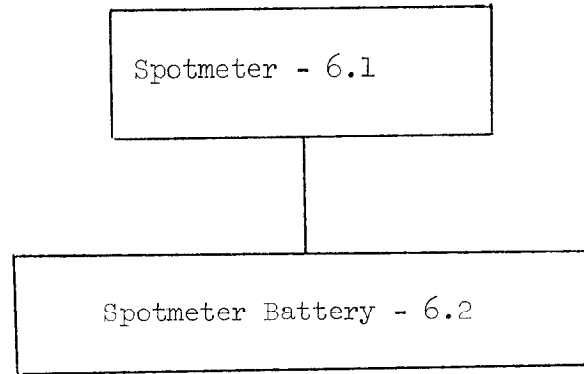

Figure 5.4-2 - ETC Installed in OWS
5.4-3

6.0

LIGHT METER SYSTEM



6.1 Spotmeter (SEB33100104):

The Spotmeter is an automatic reflectance light meter with a very narrow angle of acceptance, 1° . In use, the meter scales are rotated by a null-type servo circuit to indicate the correct aperture/shutter speed values for the selected photographic subject.

6.1.1 Significant Configuration:

<u>Configuration</u>	<u>Purpose</u>
-201	Apollo and Skylab unit.

6.1.2 Characteristics:

- Manufactured by the Minolta Camera Co., Ltd., Osaka, Japan, and distributed by the Minolta Corp., New York, New York 10003.
- Weight (with battery, see 6.2) - 1.75 lbs. (795 g.).
Envelope - 6.70 x 3.80 x 4.16 in. (17.0 x 9.7 x 10.6 cm.).
Volume - 106.0 in.³ (1735 cm.³).
- Sensitive field-of-view - 1° , centered in an 8° circular field surrounded with ASA, f-number, shutter speed, and foot-Lambert scales.
- Luminance range - 0.32 to 5000 foot-Lambert can be read directly from scale when ASA is set at 100.
- ASA film speed range - 3 to 25,000 settable with a knob on the unit front. The set value is shown at the bottom of the viewing field.
- Aperture range - f/1 to f/45.
- Shutter speed range - 30 to 1/2000 second.
- The meter objective lens is focusable from 3.3 feet to infinity.
- The viewfinder provides 4X scene magnification and is adjustable to compensate for operator vision difference.
- By fully depressing the meter operate button, internal scale illumination is provided for low light-level usage of the meter.

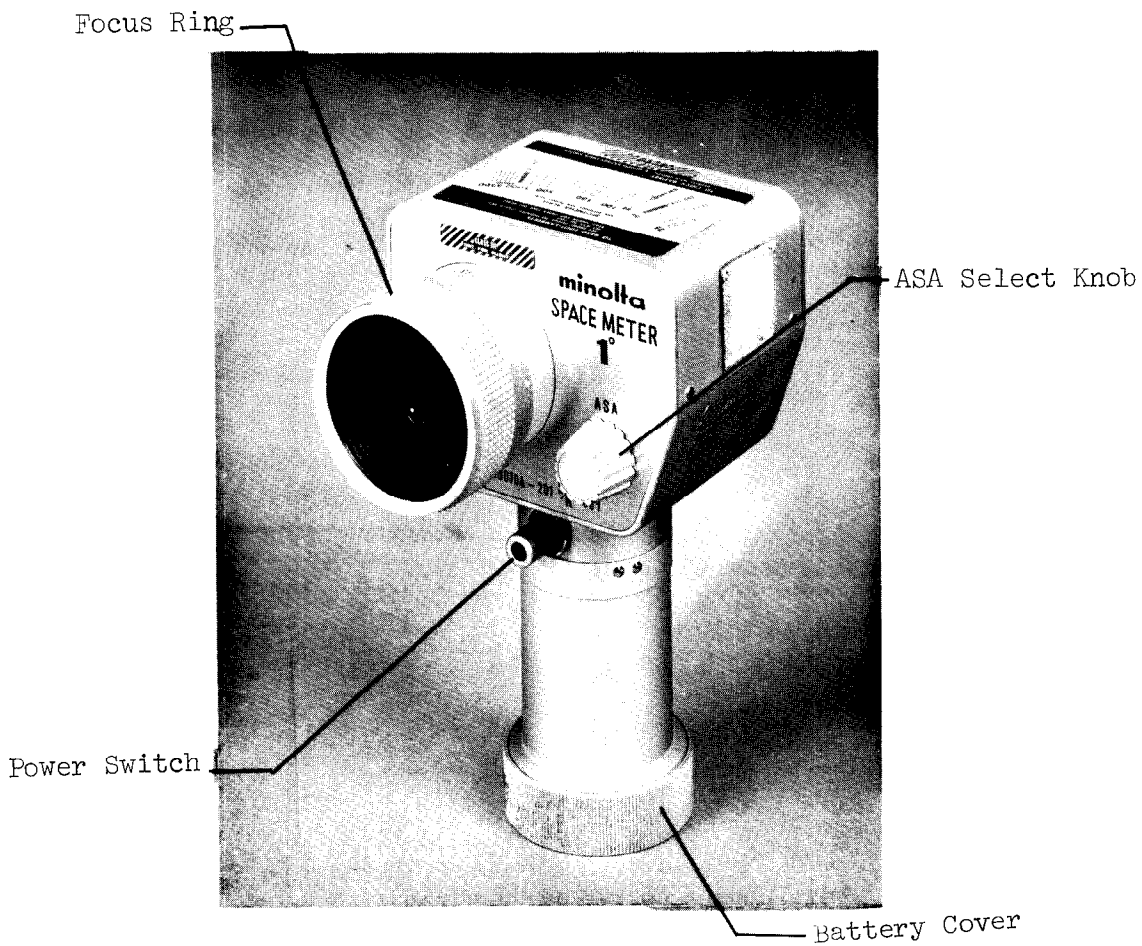

Figure 6.1-1 - Spotmeter, Front View

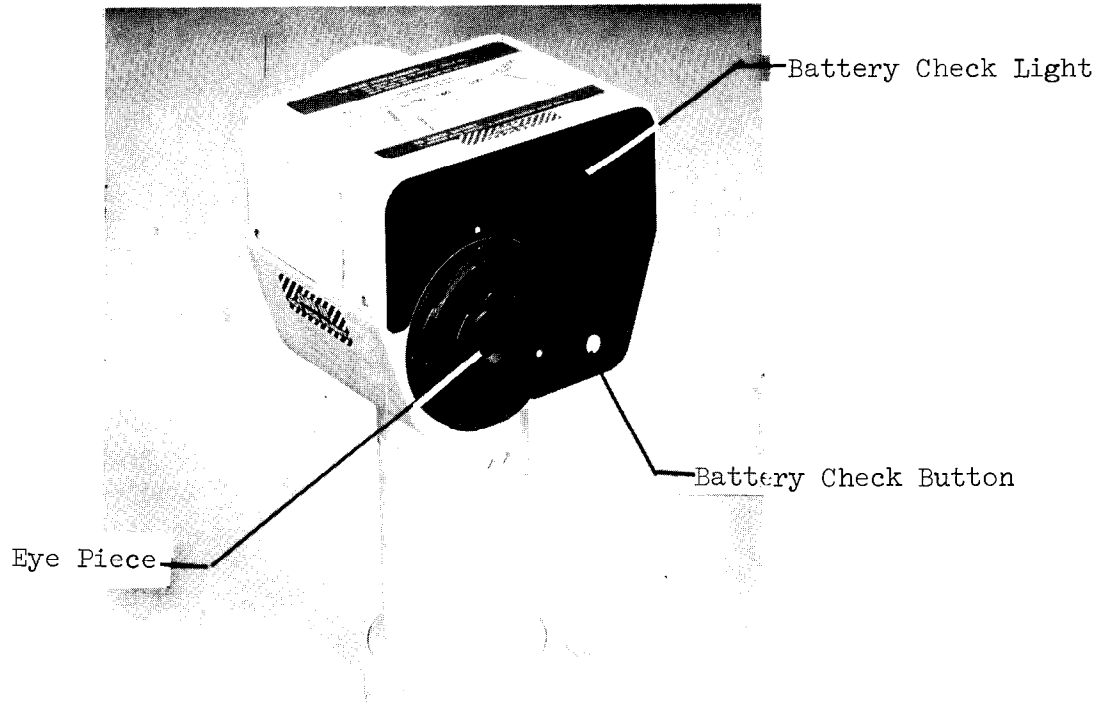

Figure 6.1-2 - Spotmeter, Rear View

- The Spotmeter is powered by a replaceable battery assembly. Separate cells for metering and for scale illumination are included in the Spotmeter Battery (see 6.2). A battery check circuit is included for the metering battery.
- When the Spotmeter is OFF, operate button released, the meter scales retain their last position and there is no battery current drain.
- A $\frac{1}{4}$ x 20 threaded hole for mounting is provided in the base of the meter handle.
- The Spotmeter is qualified for use in the Apollo and Skylab vehicles.

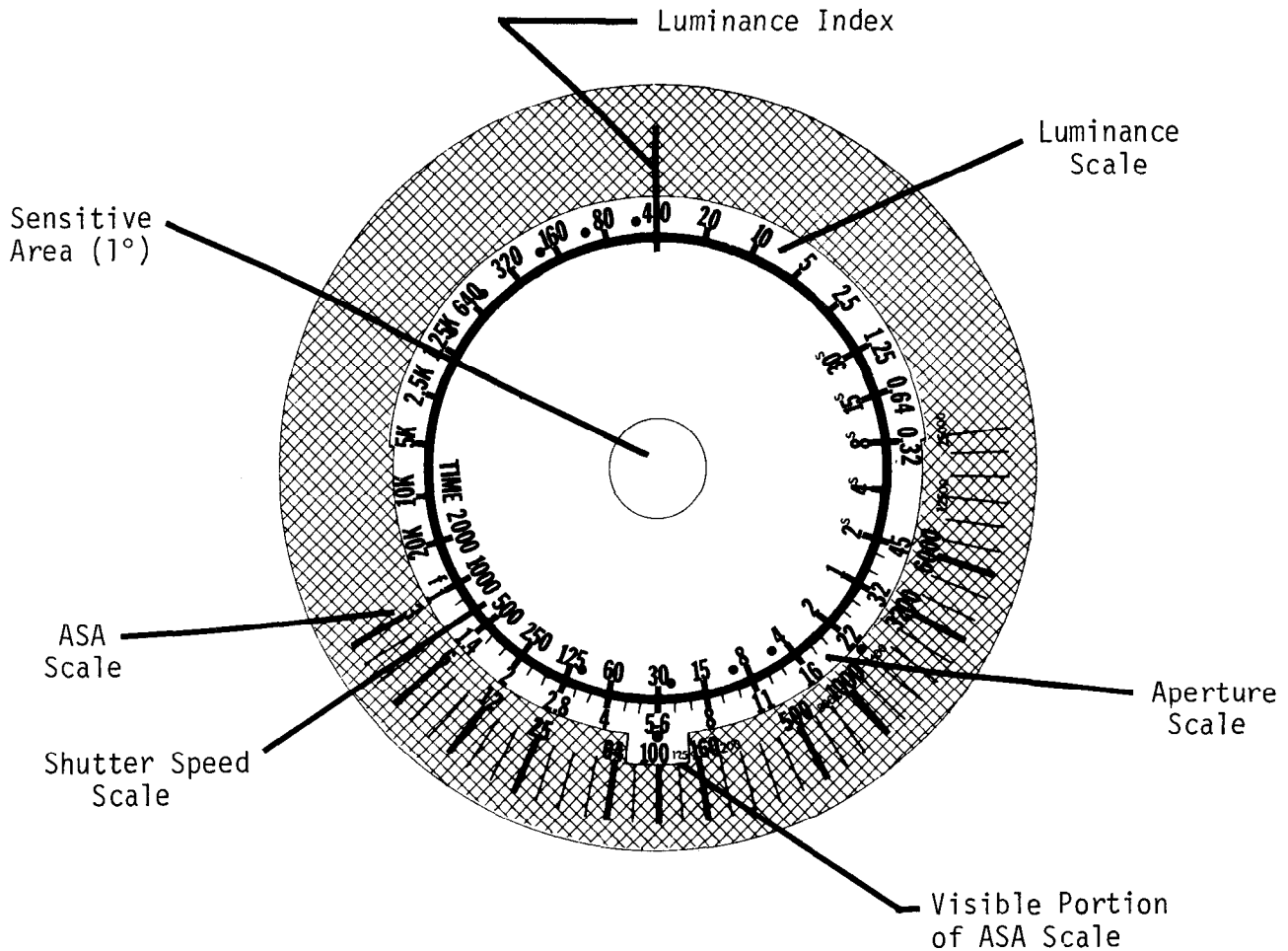

Figure 6.1-3 - Spotmeter Scales

6.2 Spotmeter Battery (SEB33100064):

The Spotmeter Battery is a replaceable, potted battery assembly for the Spotmeter (see 6.1). This battery includes two separate power sources - one for the metering and one for the scale illumination of the Spotmeter.

6.2.1 Significant Configurations:

<u>Configuration</u>	<u>Purpose</u>
-201	Apollo and Skylab unit.

6.2.2 Characteristics:

- Manufactured by Technical Services Division, NASA MSC, Houston, Texas 77058.
- Weight - 0.20 lb. (90.8 g.).
Envelope - 2.14 x 1.53 Dia. in. (5.44 x 3.89 Dia. cm.).
Volume - 3.93 in.³ (64.4 cm.³).
- The Spotmeter Battery power source for the metering circuitry is six laminated oxidized silver cells type S-76E per Union Carbide Corp. The cells are stacked and spotwelded together. Nominal open circuit voltage is 9.0 $\begin{smallmatrix} +0.8 \\ -0.2 \end{smallmatrix}$ VDC.
- The power source for the Spotmeter scale illumination is a single alkaline-manganese dioxide cell type E91 per Union Carbide Corp. The nominal open circuit voltage is 1.5 \pm 0.1 VDC.
- The two power sources are potted together with their separate electrical leads and contacts (4 total) to form a keyed battery assembly that fits into the Spotmeter handle, contacts first. The keyed shape of the battery prohibits incorrect installation and provides the alignment necessary to connect the battery and Spotmeter contacts. The screw-on battery cover of the Spotmeter firmly presses the battery against the spring contacts of the meter.
- The Spotmeter Battery is qualified for use in the Apollo and Skylab vehicles.

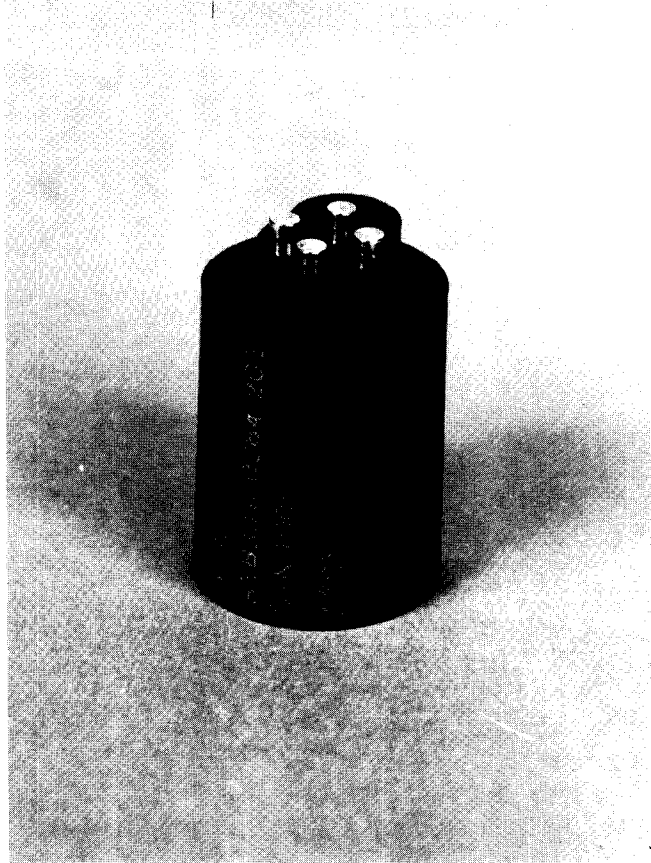
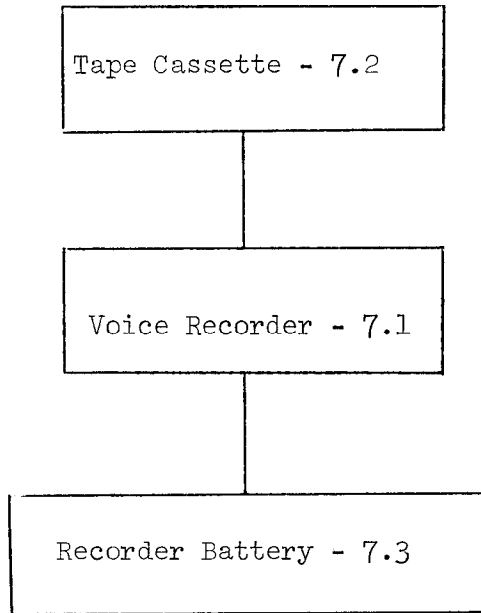

Figure 6.2-1 - Spotmeter Battery

7.0

TAPE RECORDER SYSTEM



7.1 Voice Recorder (SEB33100262):

The Voice Recorder is a small, fully portable cassette tape recorder used during the Apollo missions to record crew notes and comments and to play music selections for crew relaxation. The unit is primarily the commercial Sony Cassette-Corder Model TC-50 with only minor modifications to meet the materials requirements of manned space flight.

7.1.1 Significant Configurations:

<u>Configuration</u>	<u>Purpose</u>
-302	Apollo unit.

7.1.2 Characteristics:

- Manufactured by Sony Corporation, Sun Valley, California 91352, and modified by Flight Crew Integration Division, NASA MSC, Houston, Texas 77058.
- Weight (with battery and tape cassette) - 1.25 lbs. (567 g.).
Envelope - 5.61 x 3.61 x 1.55 in. (14.2 x 9.2 x 3.9 cm.).
Volume - 31.4 in.³ (515 cm.³).
- The Voice Recorder is powered by a replaceable Recorder Battery Assembly (see 7.3). The battery can operate the recorder for approximately 2 hours of continuous recording or 3 hours of continuous playing. A battery check meter is included.
- The recorder uses the standard Tape Cassettes (see 7.2) that can be installed or removed easily. The cassette usage indicator is visible through the cassette compartment door of the recorder.
- Tape speed - 1-7/8 inches per second.
- For playback operation, the FWD-STOP lever is placed to FWD. The playback volume is controllable with the PB VOL knob. Rapid advancement of the tape results when the REWIND/FAST FORWARD button is depressed during playback operation.
- Rewinding of the tape results while REWIND/FAST FORWARD button is depressed when FWD-STOP lever is at STOP.
- Recording is accomplished by placing lever to FWD while depressing red record (REC) button. The incorporated microphone is used and the recording level monitored at the REC/BATT meter.

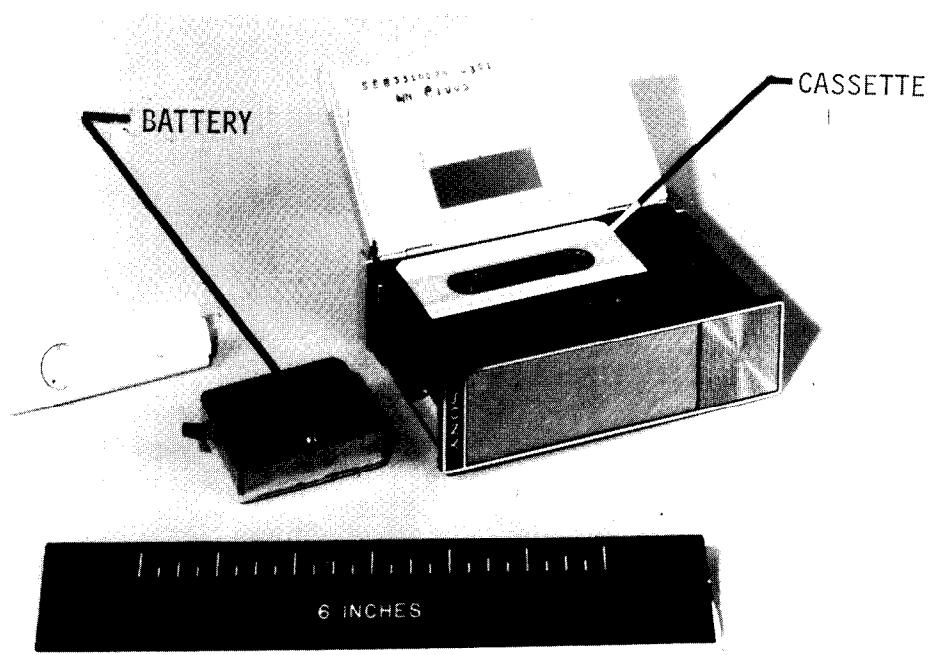

Figure 7.1-1 - Voice Recorder with Cassette and Battery

7.1-2

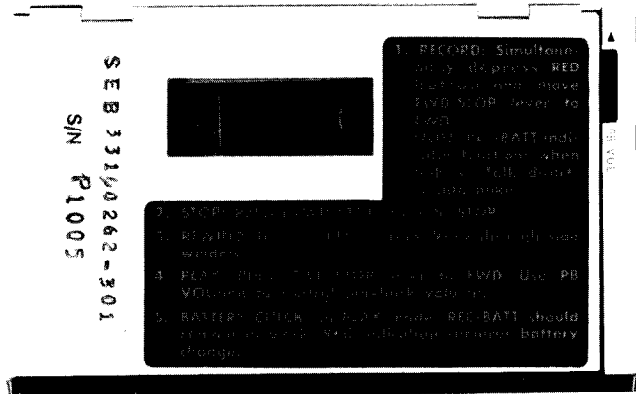

Figure 7.1-2 - Voice Recorder, Side View

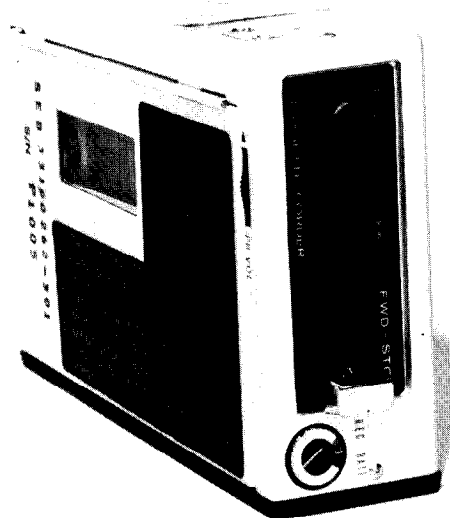

Figure 7.1-3 - Voice Recorder Controls

7.1-3

- A metal label providing brief operation procedures is affixed to the cassette compartment door.
- The Remote Control Jack, Microphone Jack, Monitor Jack, and External Power Input openings are covered with adhesive tape and are not available for use in flight operations.
- The Voice Recorder is qualified for use in the Apollo vehicles.

7.2 Tape Cassette (SEB33100263):

The Tape Cassette contains the magnetic recording tape for use in the Voice Recorder (see 7.1). Standard commercial tape cassettes are used with the addition of NASA identification and a tape retention device.

7.2.1 Significant Configurations:

<u>Configuration</u>	<u>Purpose</u>
-301	Apollo unit; 120 minutes of tape per cassette.
-302	Apollo unit; 60 minutes of tape per cassette.

7.2.2 Characteristics:

- Manufactured by Minnesota Mining and Manufacturing Co., St. Paul, Minnesota 55101, and configured by Flight Crew Integration Division, NASA MSC, Houston, Texas 77058.
- Weight - 0.10 lb. (45.4 g.).
Envelope - 4.02 x 2.53 x 0.46 in. (10.2 x 6.6 x 1.2 cm.).
Volume - 4.7 in.³ (75.6 cm³).
- Tape capacity (-301) - 120 min. total, 60 min. per side.
(-302) - 60 min. total, 30 min. per side.
- Cassette assembly includes a tape retainer to keep the magnetic tape from moving or unwinding during handling and stowage. The retainer is attached to the cassette with adhesive tape.
- The commercial annotation area is available on the cassette for notes on subject matter by crewmen. If the cassette is prerecorded with voice and/or music, the subject matter is stated in the annotation area preflight.
- The Tape Cassette is qualified for use in the Apollo vehicles.

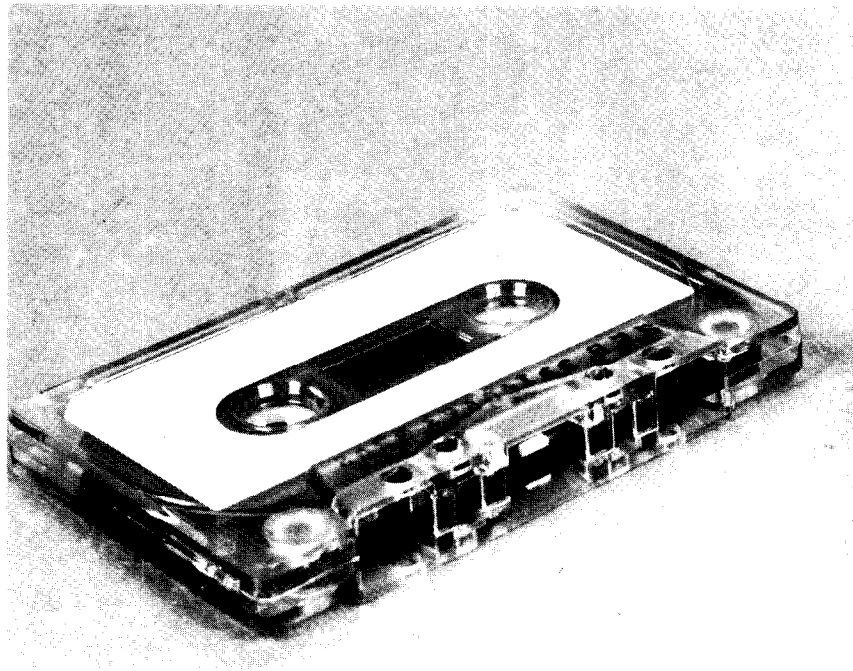

Figure 7.2-1 - Tape Cassette

7.3 Recorder Battery (SEB33100264):

The Recorder Battery is a replaceable assembly for powering the Voice Recorder (see 7.1). The assembly is only a slight modification of the commercial Sony Battery Pack BP-15 containing three AA size batteries.

7.3.1 Significant Configurations:

<u>Configuration</u>	<u>Purpose</u>
-301	Apollo unit.

7.3.2 Characteristics:

- Housing manufactured by Sony Corporation, Sun Valley, California 91352, and total assembly configured by Flight Crew Integration Division, NASA MSC, Houston, Texas 77058.
- Weight - 0.20 lb. (91 g.).
Envelope - 2.12 x 1.75 x 0.65 in. (5.4 x 4.5 x 1.6 cm.).
Volume - 2.41 in.³ (39.5 cm.³).
- The Recorder Battery power source is three alkaline manganese cells type Mn-1500 per Mallory Battery Company, Tarrytown, New York 10591. The cells are housed and interconnected in series in the Sony BP-15 Battery Pack. Nominal open circuit voltage is 4.5 VDC with capacity sufficient for approximately 3 hours play or 2 hours record.
- The Recorder Battery shape is keyed and marked to prevent incorrect installation in the Voice Recorder. The housing cover and openings are taped securely to insure the integrity of the assembly.
- The Recorder Battery is qualified for use in the Apollo vehicles.

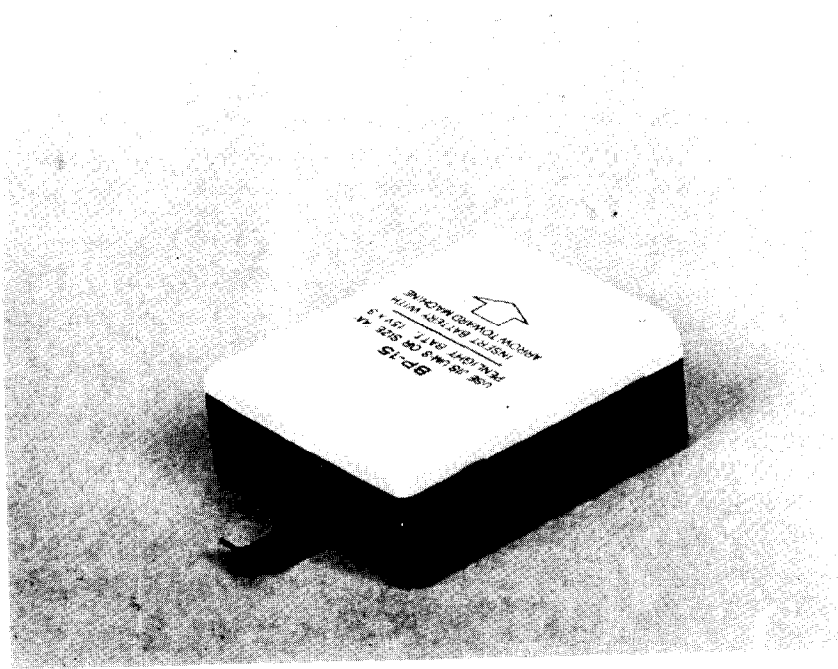

Figure 7.3-1 - Recorder Battery

8.0 Miscellaneous Support Equipment

Monocular - 8.1
Binocular - 8.2
Sunglasses and
Pouch - 8.3

Chronograph - 8.4
Watchband - 8.4
Timer - 8.5

Data Recording Pen -
8.6
Pencil - 8.7
Marker Pen - 8.8

B

Slide Rule - 8.9
Exerciser - 8.10
Meter Cover - 8.11
Tape - 8.12
Lens Brush - 8.13
Clip for Data
File - 8.17
Motion Sickness
Bag - 8.18

EVA Retractable Tether -
8.14
EVA Cuff Checklist - 8.15
Wrist Mirror - 8.16

8.0 Miscellaneous Support Equipment

- | | | | |
|---|--|---|---|
| B | Leak Rate Indicator - 8.19
Utility Bag - 8.20
Optics Cleaning Kit - 8.21 | B | Large Data Card Kit - 8.30
Auto. Flash & Battery
Assy. Bag - 8.31
Bag Assy. for 35 mm.
Camera Lens - 8.32 |
| B | ATM Board Assy. - 8.22
Knee Board Assy. - 8.23
Double Clipboard
Assy. - 8.24
Double Clip Assy.- 8.25
Support Equipment
Container Assy.- 8.26 | B | Teleprinter Message
Book - 8.33
Flight Data File
Book Assy. Backs-8.34
Data Card Assy.
Kit - 8.35
Data Card Kit
Spring - 8.36
Tape Dispenser - 8.37 |
| B | Book Tether Assy. - 8.27
Earth Orbital Map - 8.28
United States Map - 8.29 | | |

8.1 Monocular 10 x 40 (SEBL2100078):

The Monocular is a single eye telescopic viewing device actually made from one half of the commercial equivalent of the Binocular 10 x 40 (see 8.2).

8.1.1 Significant Configurations:

<u>Configuration</u>	<u>Purpose</u>
-302	Early Apollo unit; modification per MSC
-303	Apollo unit; modification per E. Leitz Inc.

8.1.2 Characteristics:

- Manufactured by Ernst Leitz GmbH, Wetzlar, West Germany, and distributed by E. Leitz, Inc., Rockleigh, N. J. 07647.
- Weight - 0.70 lbs. (318 g.)
Envelope - 5.56 x 2.87 x 1.81 in. (14.1 x 7.3 x 4.6 cm.)
Volume - 28.9 in.³ (473 cm.³)
- Magnification - 10X \pm 5%
Field-of-view - 7° Dia.
Closest focus - approximately 36 feet (9.5 meters)
- Objective diameter - 40 mm.
Exit pupil diameter - 4 mm. \pm 5%
Exit pupil location - 10.8 mm. behind eyepiece
Transmission - 71%
- The focus of the Monocular is adjusted by turning the knob closest to the eyepiece. No eyepiece adjustment is provided for this unit.
- The Monocular 10 x 40 is qualified for use in the Apollo vehicles.

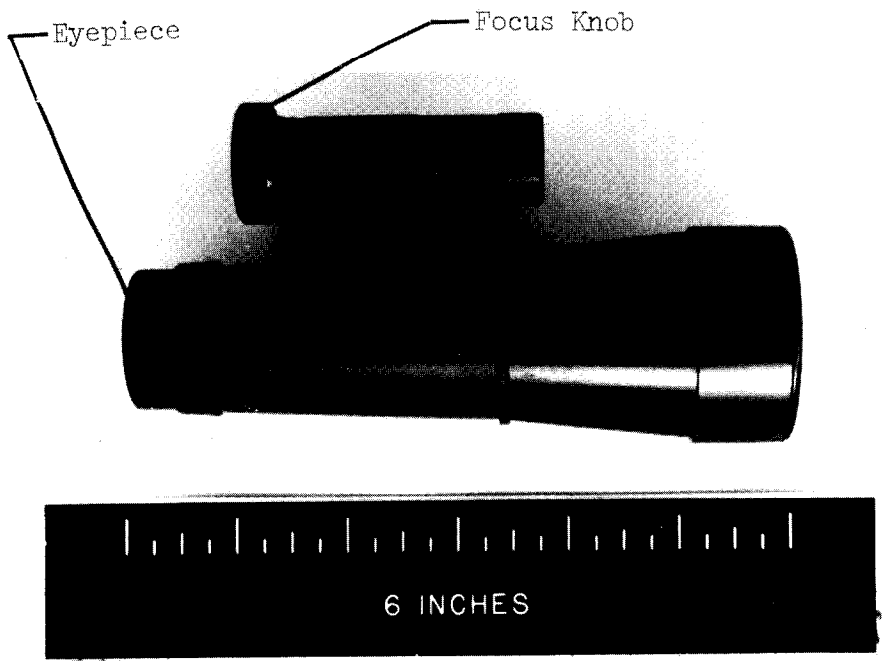

Figure 8.1-1 - Monocular 10 x 40
8.1-2

8.2 Binocular 10 x 40 (SEB12100037):

The Binocular 10 x 40 is a space modified version of the commercial Leitz Trinovid 10 x 40 binoculars. This unit is noted especially for its small size, high magnification, wide field-of-view, and rugged sealed construction.

8.2.1 Significant Configurations:

<u>Configuration</u>	<u>Purpose</u>
-202	Apollo and Skylab unit

8.2.2 Characteristics:

- Manufactured by Ernst Leitz GmbH, Wetzlar, West Germany, and distributed by E. Leitz, Inc., Rockleigh, N.J. 07647.
- Weight - 1.21 lbs. (550 g.)
Envelope - 5.55 x 4.82 x 1.83 in. (14.1 x 12.2 x 4.7 cm.)
Volume - 49.0 in.³ (802 cm.³)
- Magnification - 10X \pm 5%
Field-of-view - 7° Dia.
Closest focus - approximately 36 ft. (9.5 meters)
- Objective diameter - 40 mm.
Exit pupil diameter - 4 mm. \pm 5%
Exit pupil location - 10.8 mm. behind eyepiece
Transmission - 71%
- The focus of the Binocular is adjusted by turning the knob closest to the eyepieces.
- Right eyepiece adjustment for viewing equalization is provided by turning the knob closest to the objectives.
- The Binocular 10 x 40 is qualified for use in the Apollo and Skylab vehicles.

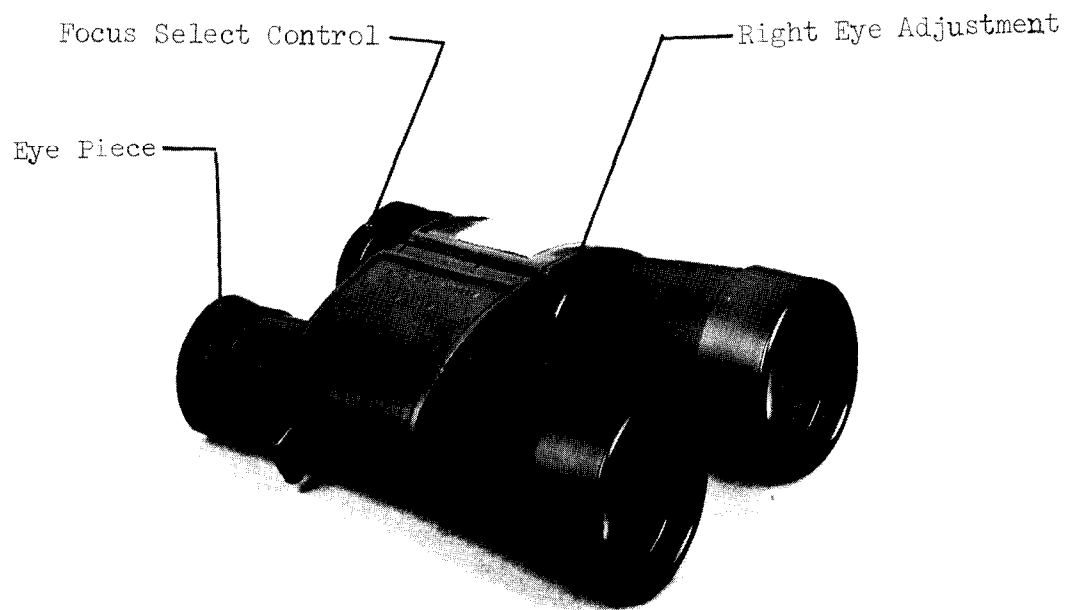

Figure 8.2-1 - Binocular 10 X 40

8.3 Sunglasses (SEB12100033) and Pouch (SEB12100034):

The Sunglasses and Pouch are used by the crewmen for general eye protection during unhelmeted mission operations.

8.3.1 Significant Configurations:

<u>Configuration</u>	<u>Purpose</u>
SEB12100033-201	Apollo and Skylab sunglasses
SEB12100034-203	Apollo and Skylab sunglasses pouch

8.3.2 Characteristics:

- Configured or manufactured by Flight Crew Integration Division, NASA, MSC, Houston, Texas 77058.
- Weight (combined) - 0.10 lbs. (45 g.).
Envelope (combined-stowed) - 6.8 x 5.5 x 0.8 in. (17.3 x 14.0 x 2.0 cm.)
Volume - 30.0 in.³ (490 cm.³)
- The Sunglasses are obtained under Federal Stock No. 8465-753-6261. The lenses are replaced with safety plastic lenses to remove the hazard of breakage.
- The Pouch provides protection during stowage and is made of Teflon coated Beta fabric.
- The Sunglasses and Pouch are qualified for use in the Apollo and Skylab vehicles.

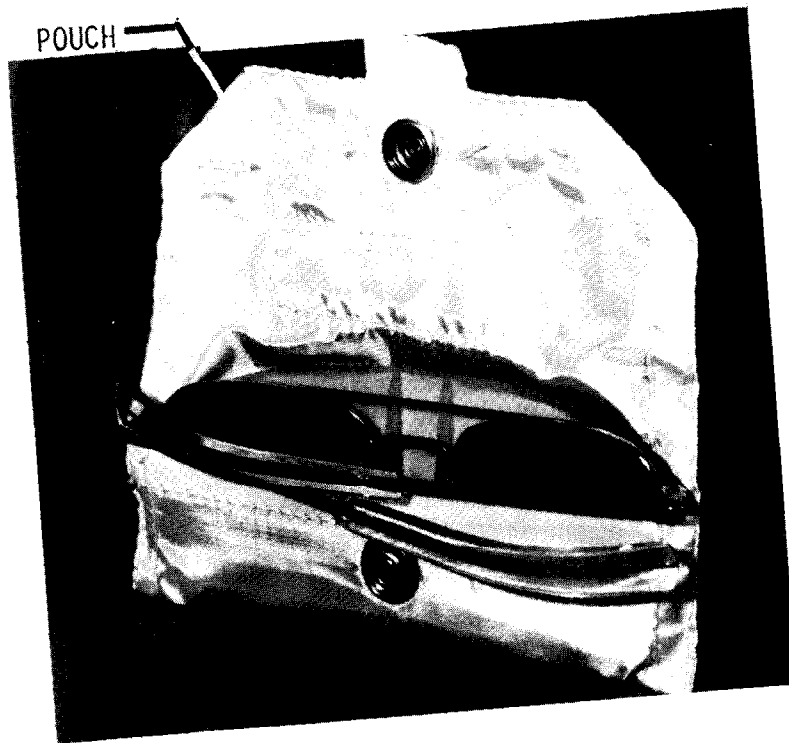

Figure 8.3-1 - Sunglasses and Pouch

8.4 Chronograph (SEB12100039) and Watchband (SEB12100030):

The Chronograph and its Watchband provide the crewman with an accurate, settable timepiece with stopwatch capability.

8.4.1 Significant Configurations:

<u>Configuration</u>	<u>Purpose</u>
SEB12100039-002	Apollo and Skylab chronograph
SEB12100030-202	Apollo and Skylab watchband
SEB12100030-210	Skylab short watchband

8.4.2 Characteristics:

- Chronograph manufactured by Omega Watch Co., Bienne, Switzerland, and distributed by Norman M. Morris Corp., New York, N. Y. 10016, as "Speedmaster Professional Chronograph," Model No. 6129. The Watchband is manufactured by NASA, MSC, Houston, Texas 77058.
- Weight (combined) - 0.20 lbs. (91 g.)
Envelope - 1.8 x 1.8 x 0.6 in. (4.6 x 4.6 x 1.5 cm.)
Volume - 1.9 in.³ (32 cm.³)
- Chronograph features -
Hour, minute, and second hands independent of stopwatch functions.
Hour, minute, and second dials for elapsed time (stopwatch) operation.
Start-stop button for stopwatch operation.
Reset button for stopwatch operation.
Maximum elapsed time possible with stopwatch function is 12 hours.
Manual winding.
Tachometer outer scale.
Black oxidized dial with luminous markers.
Antimagnetic, shock protected in a waterproof, stainless steel case.
- The -202 Watchband strap is made of Velcro pile fabric with sections of Velcro hook fabric for adjustable fastening. Total length is 21.5 in. (54.6 cm.). The Watchband is looped through the strap-pins of the Chronograph. This band is used for wearing the chronograph when suited.

- The -210 Watchband strap is made of Velcro pile fabric with sections of Velcro hook fabric for adjustable fastening. Total length is 11.5 in. (29.2 cm.). This Watchband is used for wearing the Chronograph and/or passive dosimeter P/N SEC39108180 while unsuited. The band is looped through the strap-pins on the Chronograph and through the strap cutouts on the passive dosimeter.

- The Wrist Mirror (see 8.16) can be attached to the Watchband by running the strap through the slots of the mirror.
- The Chronograph and Watchband are qualified for use in the Apollo and Skylab vehicles and on the lunar surface.



Figure 8.4-1 - Chronograph and Watchband

8.5 Timer (SEB33100092):

The Timer is a mechanical device for signaling the end of a pre-settable time interval. The Timer has two speeds and can accommodate intervals up to 60 minutes duration.

8.5.1 Significant Configurations:

<u>Configuration</u>	<u>Purpose</u>
-302	Apollo and Skylab unit

8.5.2 Characteristics:

- Manufactured by M. H. Rhoder, Inc., Hartford, CT 01606.
- Weight - 0.40 lbs. (182 g.)
Envelope - 2.05 x 2.75 Dia. in. (5.2 x 7.0 Dia. cm.)
Volume - 12.2 in.³ (199 cm.³)
- Timer scale values are from 0 to 6 with marks every 1/12.
At X1 speed, timing interval is 0 to 6 minutes with each mark representing 5 seconds.
At X10 speed, timing interval is 0 to 60 minutes with each mark representing 50 seconds.
- The Timer bell sounds once at the end of the set time interval.
- The Timer is qualified for use in the Apollo and Skylab vehicles.

TIME CONTROL

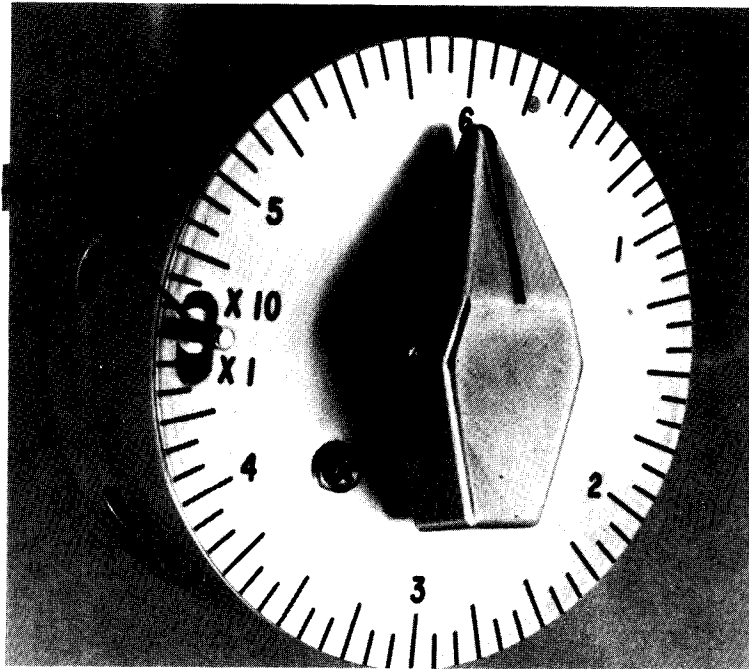

Figure 8.5-1 - Timer

8.6 Data Recording Pen (SEB12100051):

The Data Recording Pen is a special ballpoint pen originally developed for use in the space environment and currently sold as a commercial item also.

8.6.1 Significant Configurations:

<u>Configuration</u>	<u>Purpose</u>
-204	Apollo and Skylab unit; blue ink and end push button retractor
-207	Current replacement for -204 unit; blue ink and side button retractor
-208	Like -207 except black ink

8.6.2 Characteristics:

- Manufactured by the Fisher Pen Co., Van Nuys, CA 91401.
- Weight - 0.05 lbs. (22.7 g.)
Envelope - 5.21 x 0.52 Dia. in. (13.2 x 1.3 Dia. cm.)
Volume - 1.1 in.³ (18.2 cm.³)
- The Data Recording Pen, commercial Fisher Model AG-7, is a retractable ballpoint pen with a pressurized ink cartridge. The cartridge design makes use in zero gravity possible.
- Cartridge contains 0.682 cm.³ of ink pressurized with nitrogen gas to 50 psig. The ink supply provides approximately 15,000 feet (4,570 meters) of writing length.
- The ink is thixotropic (semi-solid gel) and liquifies only when the revolving ball shears its polymer bonds. The ink and pen are usable throughout the temperature range of -50°F (-46°C) to 160°F (71°C).
- A small patch of Velcro hook and a standard metal clip are incorporated to facilitate attachment and stowage of the pen.
- The Data Recording Pen is qualified for use in the Apollo and Skylab vehicles and in the hard vacuum of space.



Pen



Cartridge

Figure 8.6-1 - Data Recording Pen

8.7 Pencil (SEB12100081):

The Pencil is a general purpose mechanical pencil of sturdy metal construction.

8.7.1 Significant Configurations:

<u>Configuration</u>	<u>Purpose</u>
-301	Apollo and Skylab unit.

8.7.2 Characteristics:

- Manufactured by Lew Manufacturing Co., Coventry, Rhode Island 02816.
- Weight - 0.05 lb. (22.7 g.).
Envelope - 5.07 x 0.40 Dia. in. (12.9 x 1.0 Dia. cm.).
Volume - 0.6 in.³ (10.4 cm.³).
- The Pencil, commercial model Garland 35-P, is a metal mechanical pencil.
- Pencil lead is standard commercial graphite lead 2.75 x 0.036 Dia. in. (7.0 x 0.091 Dia. cm.).
- A small patch of Velcro hook and a standard metal clip are incorporated to facilitate attachment and stowage of the pencil.
- The Pencil is qualified for use in the Apollo and Skylab vehicles.



Figure 8.7-1 - Pencil

8.8 Marker Pen (SEB12100082):

The Marker Pen is a general purpose felt-tip marking pen with metallic exterior.

8.8.1 Significant Configurations:

<u>Configuration</u>	<u>Purpose</u>
-301	Apollo and Skylab unit; black ink.

8.8.2 Characteristics:

- Manufactured by the Duro Pen Co., Brooklyn, New York 11237.
- Weight - 0.05 lb. (22.7 g.).
Envelope - 5.20 x 0.55 Dia. in. (13.2 x 1.4 Dia. cm.).
Volume - 1.2 in.³ (20.6 cm.³).
- The Marker Pen, trade name "Rocket", is a felt-tip marking pen with a metal exterior.
- The marking ink capacity provides approximately 1,515 feet (462 meters) writing length and is usable to a maximum temperature of 160° F. (71° C.).
- A small patch of Velcro hook and a standard metal clip are incorporated to facilitate attachment and stowage of the pen.
- The Marker Pen is qualified for use in the Apollo and Skylab vehicles.

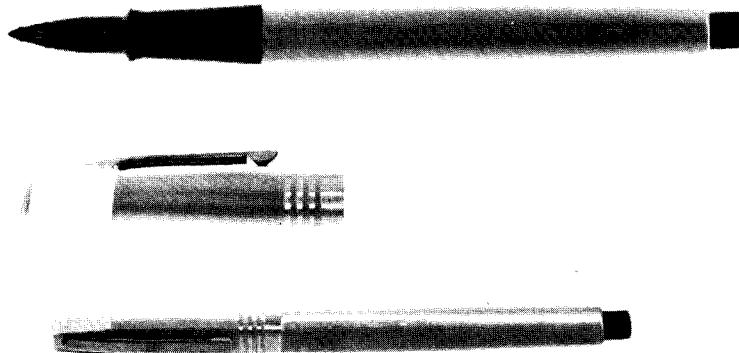

Figure 8.8-1 - Marker Pen

8.9 Slide Rule (SEB33100047):

The Slide Rule is a general purpose engineering slide rule of metal construction.

8.9.1 Significant Configuration:

<u>Configuration</u>	<u>Purpose</u>
-302	Apollo unit; yellow, Model 600ES.

8.9.2 Characteristics:

- Manufactured by Pickett and Eckel, Inc., Chicago, Illinois 60603.
- Weight - 0.07 lb. (31.8 g.).
Envelope - 6.03 x 1.54 x 0.31 in. (15.3 x 3.9 x 0.8 cm.).
Volume - 2.9 in.³ (47.2 cm.³).
- The Slide Rule is an unmodified Pickett Model 600ES Log Log slide rule and is qualified for use in the Apollo vehicles.

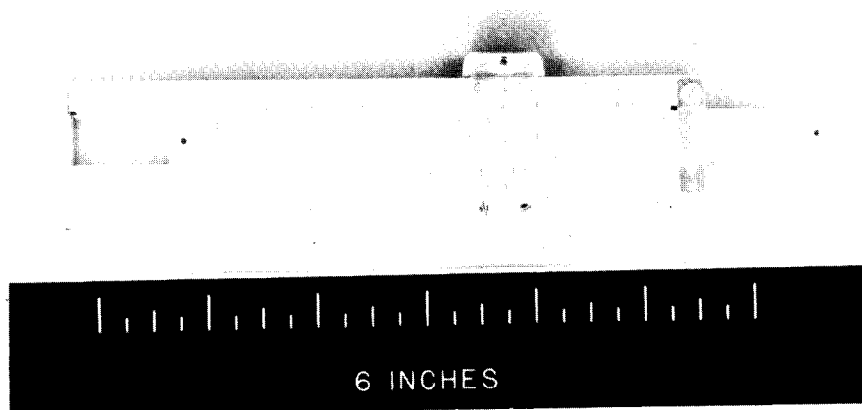

Figure 8.9-1 - Slide Rule

8.10 Exerciser (SEB33100186):

The Exerciser is a small personal exercise unit used during manned space flight to maintain muscle tone.

8.10.1 Significant Configuration:

<u>Configuration</u>	<u>Purpose</u>
-205	Apollo and Skylab unit.

8.10.2 Characteristics:

- Metal body manufactured by Diversified Products Corp., Opelika, Alabama 36801, and strap assemblies fabricated and attached by NASA MSC, Houston, Texas 77058.
- Weight - 1.40 lbs. (635 g.).
Envelope - 8.5 x 4.0 x 3.0 in. (21.6 x 10.0 x 7.6 cm.).
Volume - 102 in.³ (1670 cm.³).
- The Exerciser can be adjusted by the user to provide a working resistance of less than 1 pound (0.4 kg.) to 400 pounds (181 kg.).
- The Exerciser is qualified for use in the Apollo and Skylab vehicles.

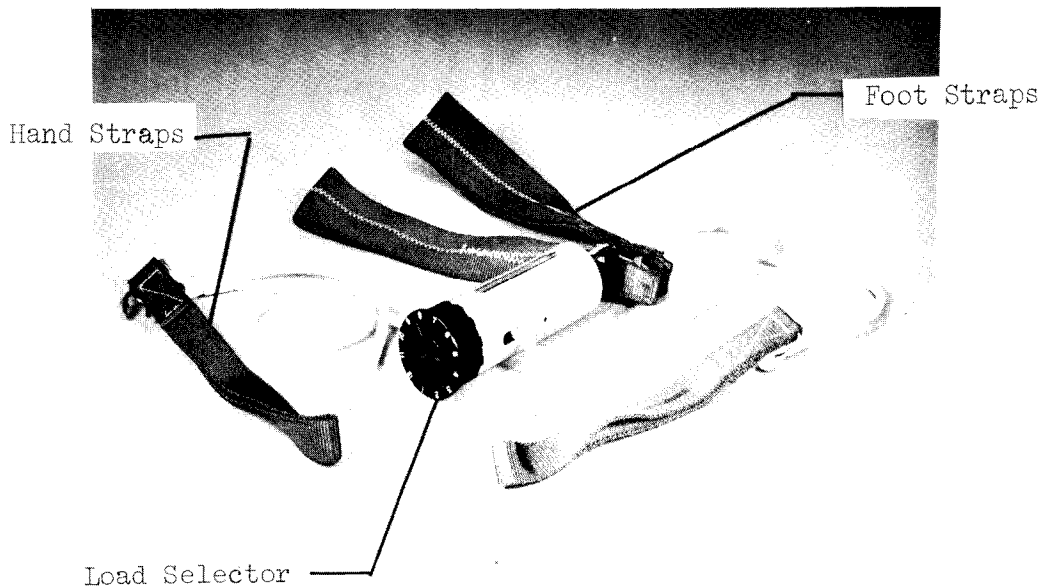

Figure 8.10-1 - Exerciser

8.11 Meter Cover (SEB33100063):

The Meter Cover assemblies are used to cover certain lighted meters to reduce the interior illumination level for experiment support.

8.11.1 Significant Configurations:

<u>Configuration</u>	<u>Purpose</u>
-301	Apollo unit; 1.87 in. diameter.
-302	Apollo unit; 2.68 inc. diameter.

8.11.2 Characteristics:

- Manufactured by Technical Services Division, NASA MSC, Houston, Texas 77058.
- Weight (-301) - 0.10 lb. (45 g.).
(-302) - 0.15 lb. (68 g.).
- Envelope (-301) - 0.40 x 1.87 Dia. in. (1.0 x 4.75 Dia. cm.).
(-302) - 0.40 x 2.68 Dia. in. (1.0 x 6.81 Dia. cm.).
- Volume (-301) - 1.1 in.³ (18 cm.³).
(-302) - 2.3 in.³ (37 cm.³).
- The metal covers include a hinged ring to aid installation and removal.
- The Meter Covers are qualified for use in the Apollo vehicles.

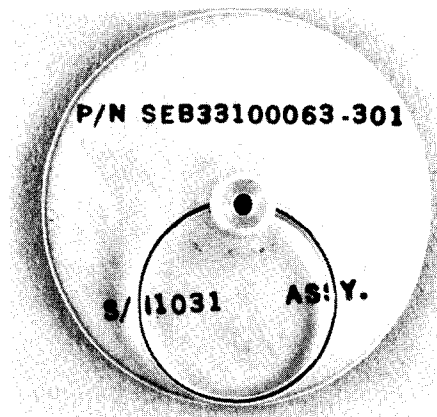

Figure 8.11-1 - Meter Covers

8.12 Tape (SEB12100050):

The Tape roll is a supply of general purpose, fabric adhesive tape for miscellaneous crew usage.

8.12.1 Significant Configurations:

<u>Configuration</u>	<u>Purpose</u>
-201	Apollo CM and Skylab unit; 180 feet.
-202	Apollo LM unit; 25 feet.
-203	Apollo LM unit; 100 feet.

8.12.2 Characteristics:

- Tape manufactured by the Kendall Co., Chicago, Illinois 60615, and roll assembled by NASA MSC, Houston, Texas 77058.
- Weight (-201) - 0.9 lb. (409 g.).
(-202) - 0.1 lb. (45 g.).
(-203) - 0.5 lb. (227 g.).
- Envelope (-201) - 1.0 x 5.8 Dia. in. (2.5 x 14.7 Dia. cm.).
(-202) - 1.0 x 2.0 Dia. in. (2.5 x 5.1 Dia. cm.).
(-203) - 1.0 x 4.0 Dia. in. (2.5 x 10.0 Dia. cm.).
- Volume (-201) - 26.4 in.³ (433 cm.³).
(-202) - 3.1 in.³ (51 cm.³).
(-203) - 12.6 in.³ (206 cm.³).
- The Tape roll is qualified for use in the Apollo and Skylab vehicles.

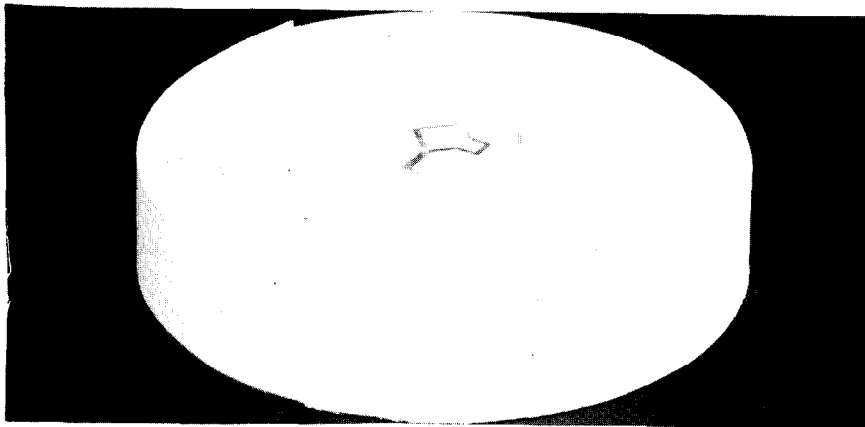

Figure 8.12-1 - Tape Roll

8.13 Lens Brush (SEB33100402):

The Lens Brush is used for removing dust particles from the glass surfaces at the initial stage of lens cleaning.

8.13.1 Significant Configuration:

<u>Configuration</u>	<u>Purpose</u>
-301	Apollo LM unit.

8.13.2 Characteristics:

- Manufactured by Technical Services Division, NASA MSC, Houston, Texas 77058.
- Weight - 0.10 lb. (45.4 g.).
Envelope - 8.0 x 0.6 Dia. in. (20.2 x 1.5 Dia. cm.).
Volume - 2.3 in.³ (37 cm.³).
- The brush hair and ferrule is attached to an aluminum handle. The brush and ferrule assembly is manufactured by M. Grumbacher, Inc., New York, New York.
- The brush handle has a 15-inch (38 cm.) nylon cord with loop attached to its end as a crew handling aid.
- The Lens Brush is qualified for use in the Apollo vehicles.

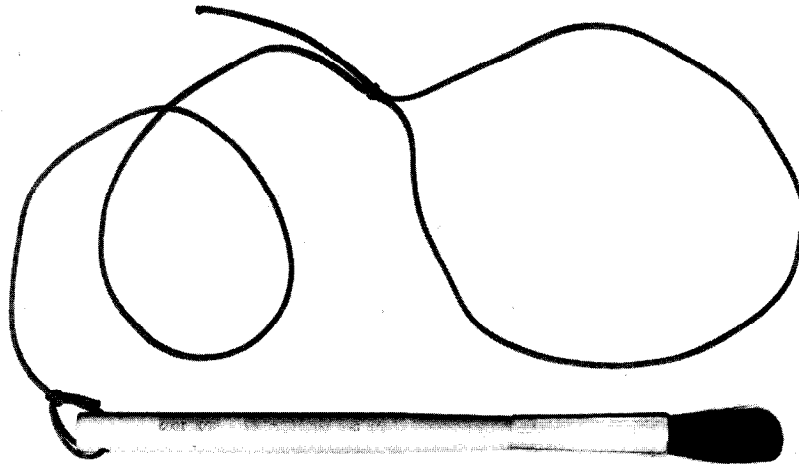

Figure 8.13-1 - Lens Brush

8.14 EVA Retractable Tether (SEB33100291):

The EVA Retractable Tether is a small, pull-cord, attachment clamp assembly for general purpose item retention during lunar surface operations. The unit is strapped to the crewmen's suit and readily available for use.

8.14.1 Significant Configurations:

<u>Configuration</u>	<u>Purpose</u>
-301	Apollo 11 through 15 unit; small left-hand unit.
-303	Apollo 15 unit; large, right-hand unit.
-304	Apollo 17 unit; small, right-hand unit with improved cord knot.
-305	Apollo 16 and 17 unit; small left-hand unit with improved cord knot.

8.14.2 Characteristics:

- Manufactured by Technical Services Division, NASA MSC, Houston, Texas 77058.
- Weight (-301, -304, -305) - 0.20 lb. (91 g.).
(-303) - 0.70 lb. (318 g.).
Envelope (-301, -304, -305) 4.3 x 1.3 x 1.2 in.
(10.9 x 3.3 x 3.0 cm.).
(-303) - 6.2 x 2.7 x 1.4 in. (15.7 x 6.9 x 3.6 cm.).
Volume (-301, -304, -305) - 6.7 in.³ (110 cm.³).
(-303) - 23.4 in.³ (384 cm.³).
- The tether retractor assembly attaches to the left or right PLSS straps (see 8.14.1) on the outside of the suit by means of an included strap. The free end of the retractor strap loops under the PLSS strap and snap-attaches to the outside of the retractor assembly. The retractor strap is 1.25 in. (3.2 cm.) wide with lengths as follows: (-301 and -305) 6.5 in. (16.5 cm.), (-303) 9.1 in. (23.1 cm.), and (-304) 6.8 in. (17.3 cm.).
- The tether cord of the retractor assembly is kept under constant tension by the retractor mechanism and is fastened securely to the tether clamp. The cord tension is 3/8 lb. (170 g.) for the -301, -304, and -305 configurations and

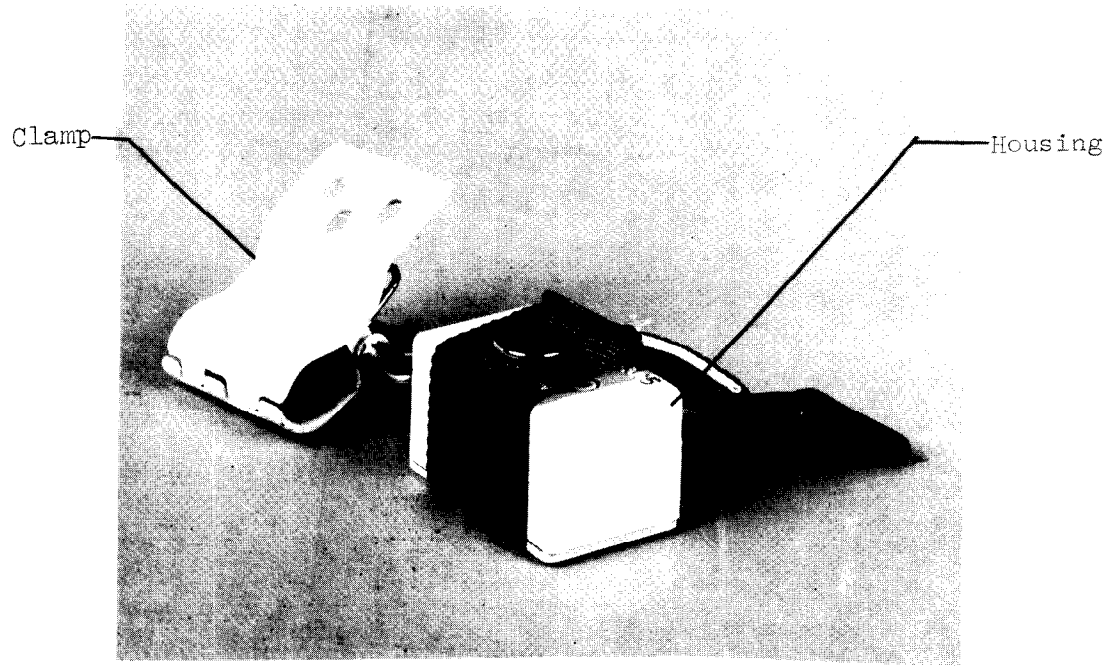

Figure 8.14-1 - Small EVA Retractable Tether (-301, -304, -305)

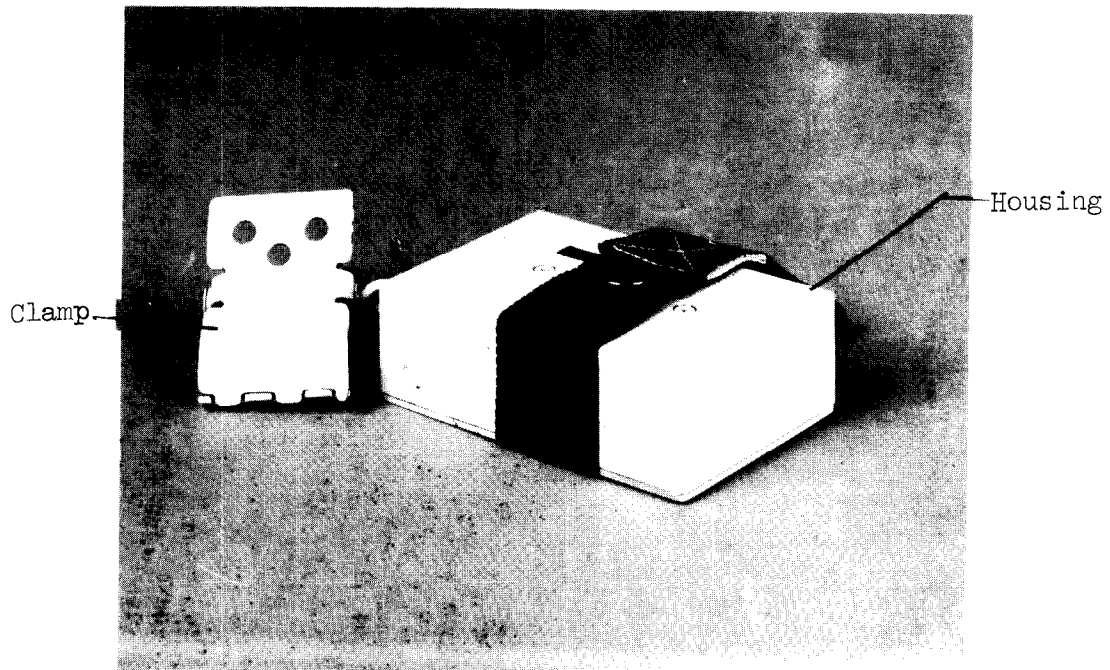

Figure 8.14-2 - Large EVA Retractable Tether (-303)

is 1 lb. (454 g.) for the -303 unit. The cord of the -301 and -303 units is 30 lbs. (13.6 kg.) test and of the -304 and -305 units is 50 lbs. (22.7 kg.) test. The usable cord length is 35 ± 1 in. (89 ± 3 cm.) for all configurations.

- The tether clamp is a double jawed, spring closure mechanism with an incorporated eyelet for attachment to the tether cord. The clamp for the small units (-301, -304, and -305) requires approximately 2 lbs. (0.9 kg.) of opening force and the large unit (-303) clamp requires about 9 lbs. (4.1 kg.).
- The EVA Retractable Tether is qualified for use in the Apollo vehicles and on the lunar surface.

8.15 Cuff Checklist for EVA (SEB33100302)

The Cuff Checklist Assembly is fabricated in two styles--one for suited crewmen and one for unsuited crewmen. The suited style assembly straps into the crewmen's suited wrist with a watchband (see 8.4). The checklist pages are attached to the assembly by a spiral wire spring that positively holds the pages open while permitting easy page turning by the crewman.

8.15.1 Significant Configuration:

<u>Configuration</u>	<u>Purpose</u>
-302	Apollo lunar surface unit
-329	Support procedure cards
-303	Support -329 on crewman in EVA suit
-304	Support -329 on crewman without EVA suit

8.15.2 Characteristics:

-302

Weight - 0.30 lb. (136 g.)
Envelope (w/o watchband) - 4.6 x 4.8 x 2.7 in. (11.7 x 12.2 x 6.9 cm.)
Volume - 59.6 in.³ (977 cm.³)

-329

Weight - .123 lb. (56 gm.)
Envelope - 1.48 x 3.48 x 4.06 in. (3.76 x 8.84 x 10.31 cm.)
Volume - 21 in.³ (344.2 cm.³)

-303

Weight - .095 lb. (43 gm.)
Envelope - 1.24 x 1.38 x 4.16 in. (3.15 x 3.51 x 10.6 cm.)
Volume - 7.12 in.³ (116.7 cm.³)

-304

Weight - .095 lb. (43 gm.)
Envelope - 1.24 x 1.38 x 4.16 in. (3.15 x 3.51 x 10.6 cm.)
Volume - 7.12 in.³ (116.7 cm.³)

•The Cuff Checklist EVA Assembly was designed, fabricated, and flight qualified at JSC.



-303

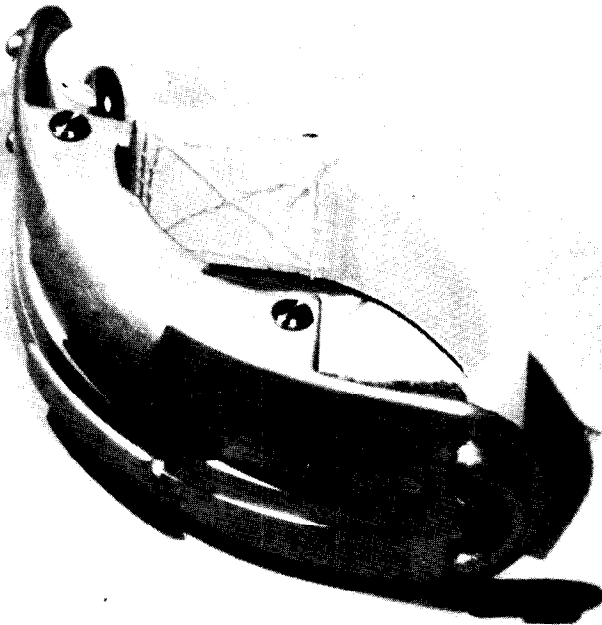

-304

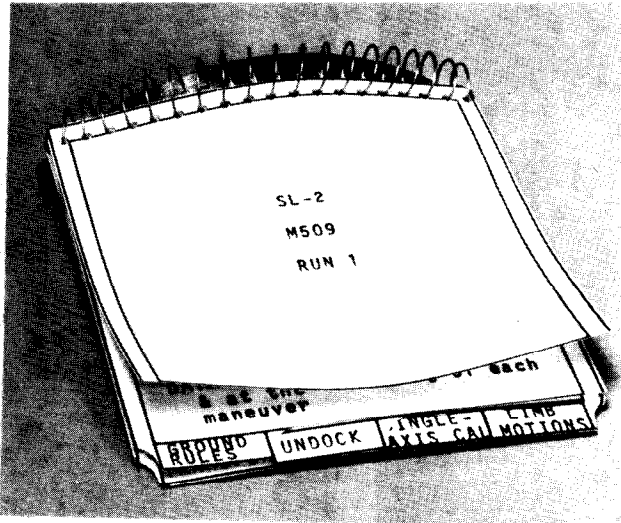

-309

Figure 8.15-1 - Cuff Bands and Spring Assembly

8.15-2

8.16 Wrist Mirror (SDB12100086):

The Wrist Mirror is used by the suited crewman to see areas of his suit or equipment that would otherwise be hidden from his view. The item is flat polished metal and attaches to the Watchband (see 8.4).

8.16.1 Significant Configuration:

<u>Configuration</u>	<u>Purpose</u>
-001	Apollo lunar surface item.

8.16.2 Characteristics:

- Manufactured by Technical Services Division, NASA MSC, Houston, Texas 77058.
- Weight - 0.05 lb. (22.7 g.).
Envelope - 1.38 x 1.26 x 0.05 in. (3.5 x 3.2 x 0.1 cm.).
Volume - 0.1 in.³ (1.4 cm.³).
- The Wrist Mirror is stainless steel with the mirror surface polished to a finish of better than 8 μ in. (2.2 μ m) rms.
- The Wrist Mirror has two slots through which the Watchband (see 8.4) is threaded. The Chronograph (see 8.4) and the Wrist Mirror together can be retained on the Watchband at the same time.
- The Wrist Mirror is qualified for use in the Apollo and Skylab vehicles and on the lunar surface.

B 8.17 Data File Clip (SEB32100094)

The Data File Clip is a general use clip for single sheets and thin (.50 thick max.) pads or books.

B 8.17.1 Significant Configuration:

<u>Configuration</u>	<u>Purpose</u>
-301	Skylab Data Card Kits

B 8.17.2 Characteristics:

•This item consists of commercial aluminum clip halves with stainless steel spring and shaft replacing these commercial parts.

•Weight - 0.59 lb. (267.5 gm.)
Envelope - 2.25 x 1.03 x 1.09 in. (5.71 x 2.62 x 2.77 cm.)
Volume - 2.2 in.³ (36 cm.³)

•The Data File Clip is qualified for use in Apollo and Skylab vehicles.

B

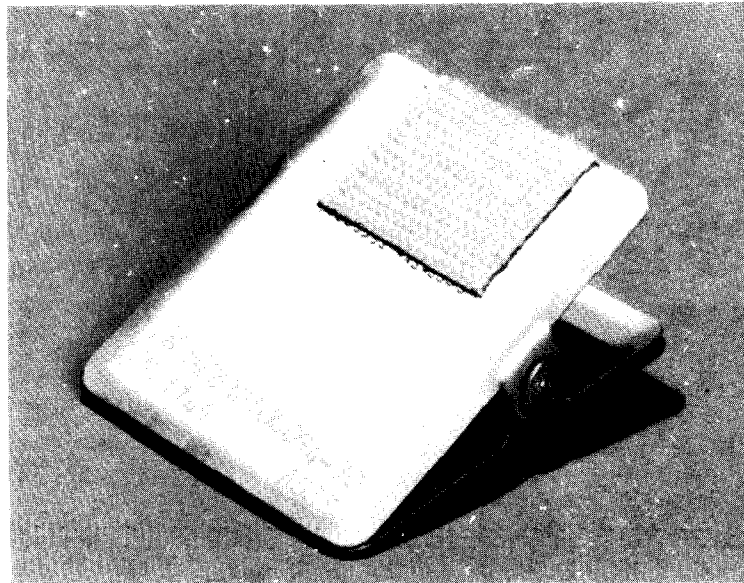

Figure 8.17-1 - Clip for Data File

8.17-1

8.18 Motion Sickness Bag (SEB12100085):

The Motion Sickness Bag is a plastic, zip-seal, bag to be used by the crewman in the event of a vomiting illness such as motion sickness.

8.18.1 Significant Configuration:

<u>Configuration</u>	<u>Purpose</u>
-301	Apollo item.

8.18.2 Characteristics:

- Fabricated by the Flight Crew Integration Division, NASA MSC, Houston, Texas 77058.
- Weight - 0.06 lb. (27 g.).
Envelope (stowed) - 4.0 x 3.0 x 1.0 in. (10.2 x 7.6 x 2.5 cm.).
Volume - 12.0 in.³ (197 cm.³).
- The Motion Sickness Bag assembly consists of the bag itself sealed in an outer evacuated bag. The Motion Sickness Bag itself is a 12.0 x 6.0 in. (30.5 x 15.2 cm.) polyethylene interlocking bag, GSA Stock No. 8105-837-7757. The outer storage bag is made of FEP-A Teflon per E. I. Dupont, Wilmington, Delaware 19898.
- The Motion Sickness Bag will hold approximately 50 in.³ (820 cm.³) of waste material.
- The bag assembly is qualified for use in the Apollo vehicles.

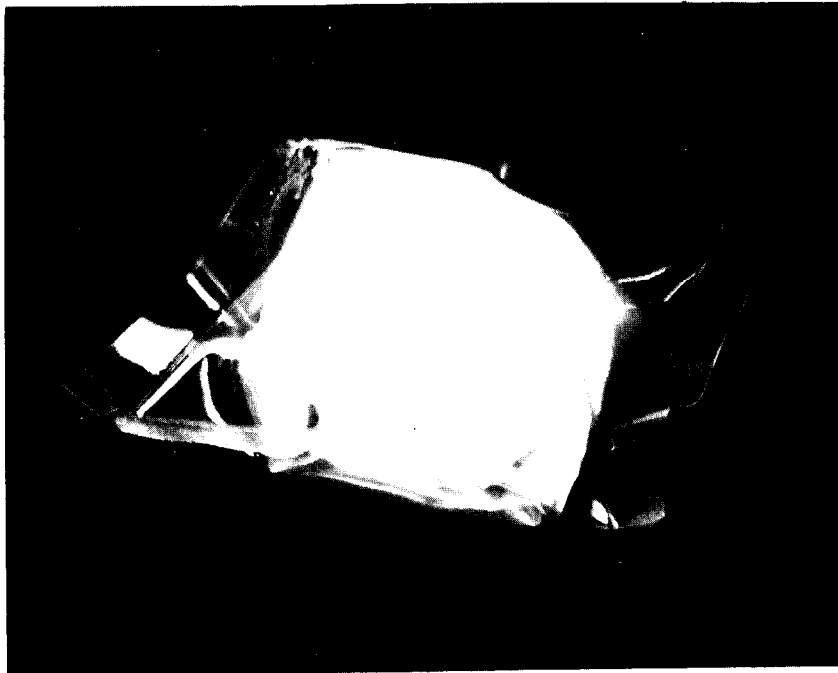

Figure 8.18-1 - Motion Sickness Bag, Stowed Configuration



Figure 8.18-2 - Motion Sickness Bag

8.19 Leak Rate Indicator (SEC32100023):

The Leak Rate Indicator is an adaptation of a commercial rate of climb aircraft instrument for use in large volume spacecraft as an atmospheric leak detector. The unit is portable for location at various work stations as required.

8.19.1 Significant Configurations:

<u>Configuration</u>	<u>Purpose</u>
-302	Used throughout the Skylab cluster as a leak detection/isolation device.

8.19.2 Characteristics:

- Manufactured by Edo-Aire of Wichita, Kansas, as a 0-2000 feet per minute rate of climb indicator. Modified by NASA to comply with crew bay materials requirements.
- Weight - 1.16 lb. (525g)
Envelope - 3.89 in. x 3.25 in. dia. (9.88 cm. x 8.25 cm. dia.)
Volume - 32.25 in.³ (528.57 cm.³)

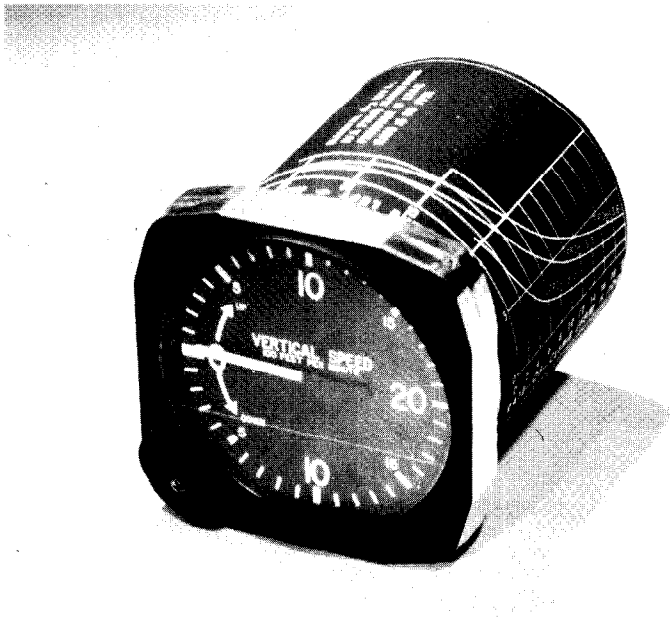

Figure 8.19-1 - View of Meter in Flight Configuration

8.20 Utility Bag (SEC12100087):

The Utility Bag is a general purpose fabric bag utilized for Astronaut Personal Kit (APK), Official Flight Kit (OFK) and miscellaneous items approved by configuration management.

8.20.1 Significant Configurations:

<u>Configuration</u>	<u>Purpose</u>
-301	Apollo and Skylab items

8.20.2 Characteristics:

- Fabricated by FCID, NASA, JSC, Houston, Texas 77058.
- Weight - 0.1 lbs. (45.4g)
Envelope - 9 x 4 x 2 in. (23 x 10 x 5 cm.)
Volume - 72 in.³ (1180 cm.³)
- The Utility Bag is fabricated of Teflon coated beta fabric type 215-190-2 or 215-141-1 per E. I. DuPont, Wilmington, Delaware 19898. A draw-cord closure is incorporated.
- The Utility Bag is qualified for use in the Apollo and Skylab vehicles.

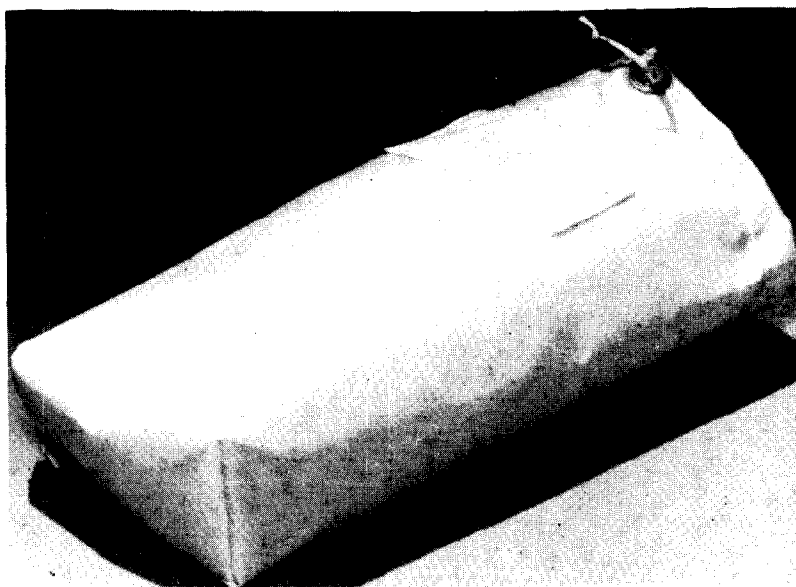

Figure 8.20-1 - Utility Bag

8.21 Optics Cleaning Kit (SEC33100890 and SEC33100891):

The Optics Cleaning Kit is a source of cleaning and handling materials for servicing optical and glass elements during periods of crew habitation. The kit is composed of two parts, a box containing cleaning fluids and materials, and a box containing gloves for use in handling optical surfaces.

8.21.1 Significant Configurations:

<u>Configuration</u>	<u>Purpose</u>
-301 (Large)	Skylab general purpose optics cleaning materials
-302 (Large)	Skylab experiment S190A cleaning materials
-301 (Small)	Skylab general purpose gloves
-302 (Small)	Skylab experiment S190A gloves

8.21.2 Characteristics:

- Fabricated by the Flight Crew Integration Division, NASA, Houston, Texas, 77058.
- The (-301) large kit contains 24 fluid oz. (0.709 liter) of distilled water, 4 fluid oz. (0.118 liter) of a 3% detergent solution, a small bellows for air dusting, two hair brushes, and quantities of clean tissues and swabs.
- The (-302) large kit is similar in makeup, with the detergent solution and swabs omitted, and additional tissues substituted.
- Weight - 5.30 lb. (2.40 Kg)
Envelope - 9.93 in. (25.22 cm.) x 3.47 in. (8.81 cm.)
x 6.94 in. (17.62 cm.)
Volume - 239.13 in.³ (3919.37 cm.³)
- The (-301) small kit contains a quantity of thin film gloves for handling optical elements without the transfer of body effluvia. The (-302) small kit is identical in makeup.

- Weight - 1.55 lb. (0.70 Kg)
Envelope - 6.38 in. (16.20 cm.) x 7.40 in. (18.79 cm.) x
1.65 (4.19 cm.)
Volume - 77.89 in.³ (1276.77 cm.³)

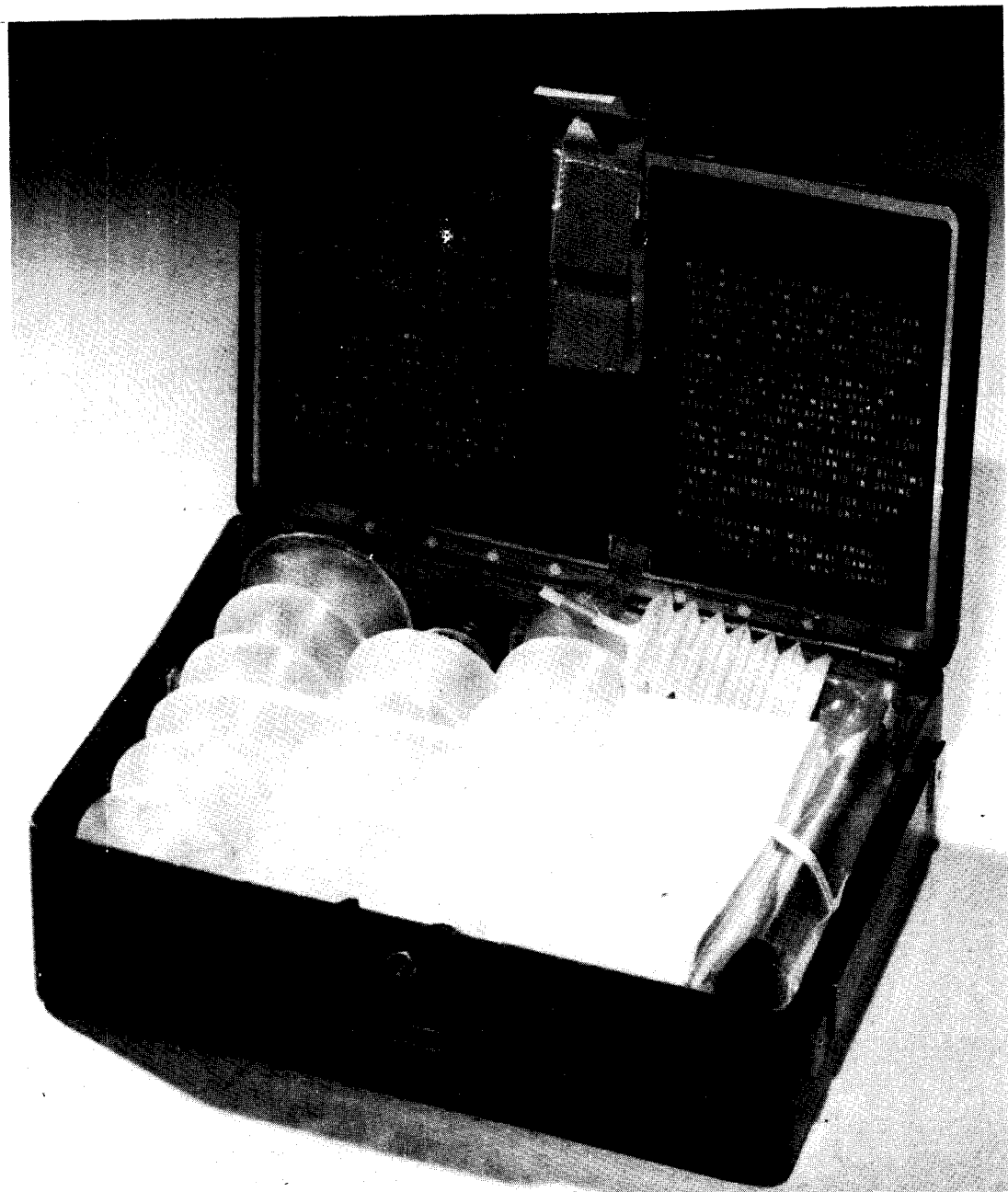
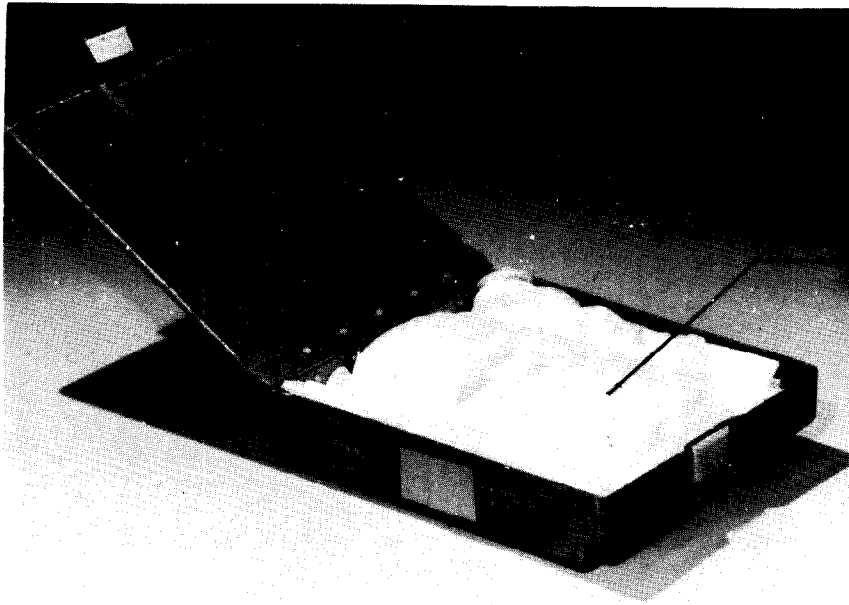

Figure 8.21-1
(-301) Optics Cleaning Kit (Large)

8.21-3



Gloves

Figure 8.21-2
(-301) Optics Cleaning Kit (Small)

8.21-4

B 8.22 ATM Board Assembly (SEC32100188)

The ATM Board Assembly is a hands-free device designed to store Joint Observing Program summary sheets and provide a smooth writing surface.

B 8.22.1 Significant Configuration:

<u>Configuration</u>	<u>Purpose</u>
-301, -302, -303	Skylab unit

B 8.22.2 Characteristics:

•The ATM boards were manufactured by Murdock, Inc., Compton, California 90220, and total assembly was configured by Flight Crew Integration Division, NASA, JSC.

•Weight - 2.5 lb. (1.1 kg.)
Envelope - 18.75 x 11.75 x 4.74 in. (47.6 x 29.8 x 12 cm.)
Volume - 1044.3 in.³ (17.1 x 10³ cm.³)

•Three ATM board assemblies were designed to interface with the ATM handrail as well as the universal mounts in the Skylab vehicles. Some summary sheets will be stored within each ATM Board. In addition, clips are provided on the writing surface of each ATM Board to retain the summary sheet being used. A large clamp is also provided on the writing surface of two of the boards for clamping data file books.

•The ATM Board assemblies are qualified for use in the Skylab vehicles.

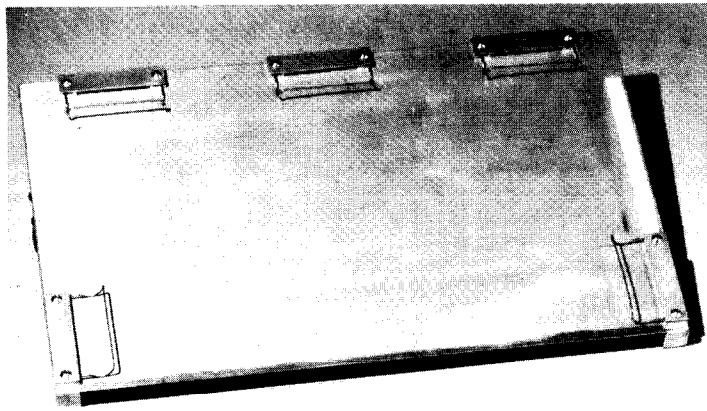

-301

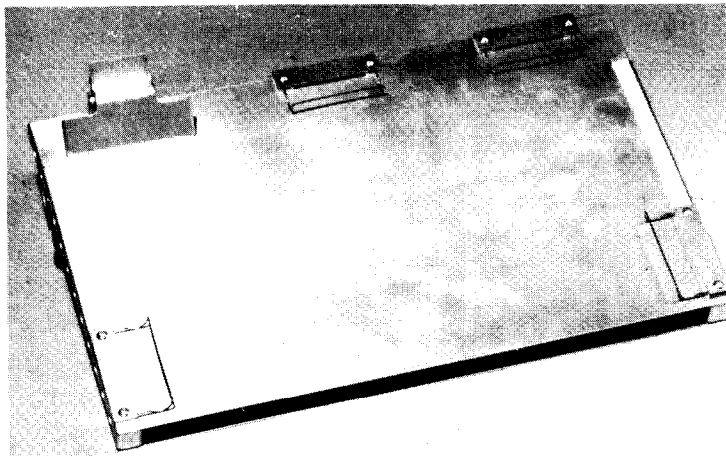

-302

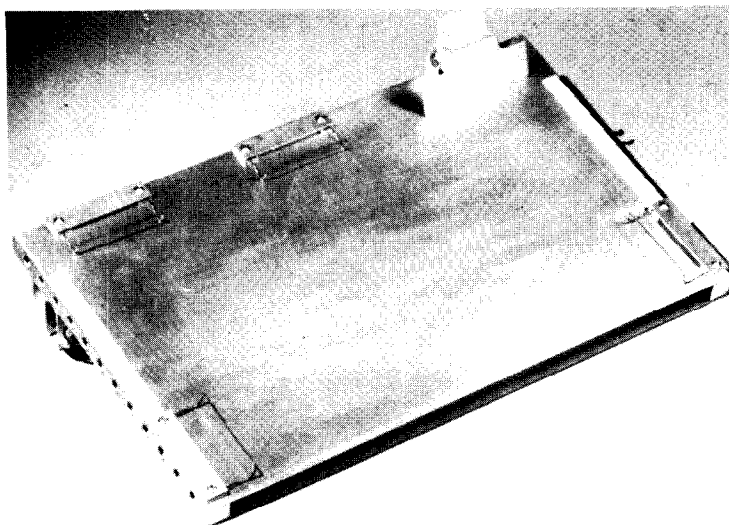

-303

Figure 8.22-1 - ATM Board Assemblies

8.22-2

B 8.23 Knee Board Assembly (SEC32100189)

The knee board is attached to the thigh of a crewman by a velcro strap. In this configuration, it is used as a clipboard to read FDF books, take notes, etc.

B 8.23.1 Significant Configuration:

<u>Configuration</u>	<u>Purpose</u>
-301	Provide writing table

B 8.23.2 Characteristics:

- Weight - .72 lb. (327 gm.)
- Envelope - 3.1 x 7.7 x 6.15 in. (7.87 x 19.6 x 15.62 cm.)
- Volume - 147 in.³ (2406 cm.³)
- Fabricated at JSC.
- Qualified for Skylab use.

B

Figure 8.23-1 - Knee Board Assembly

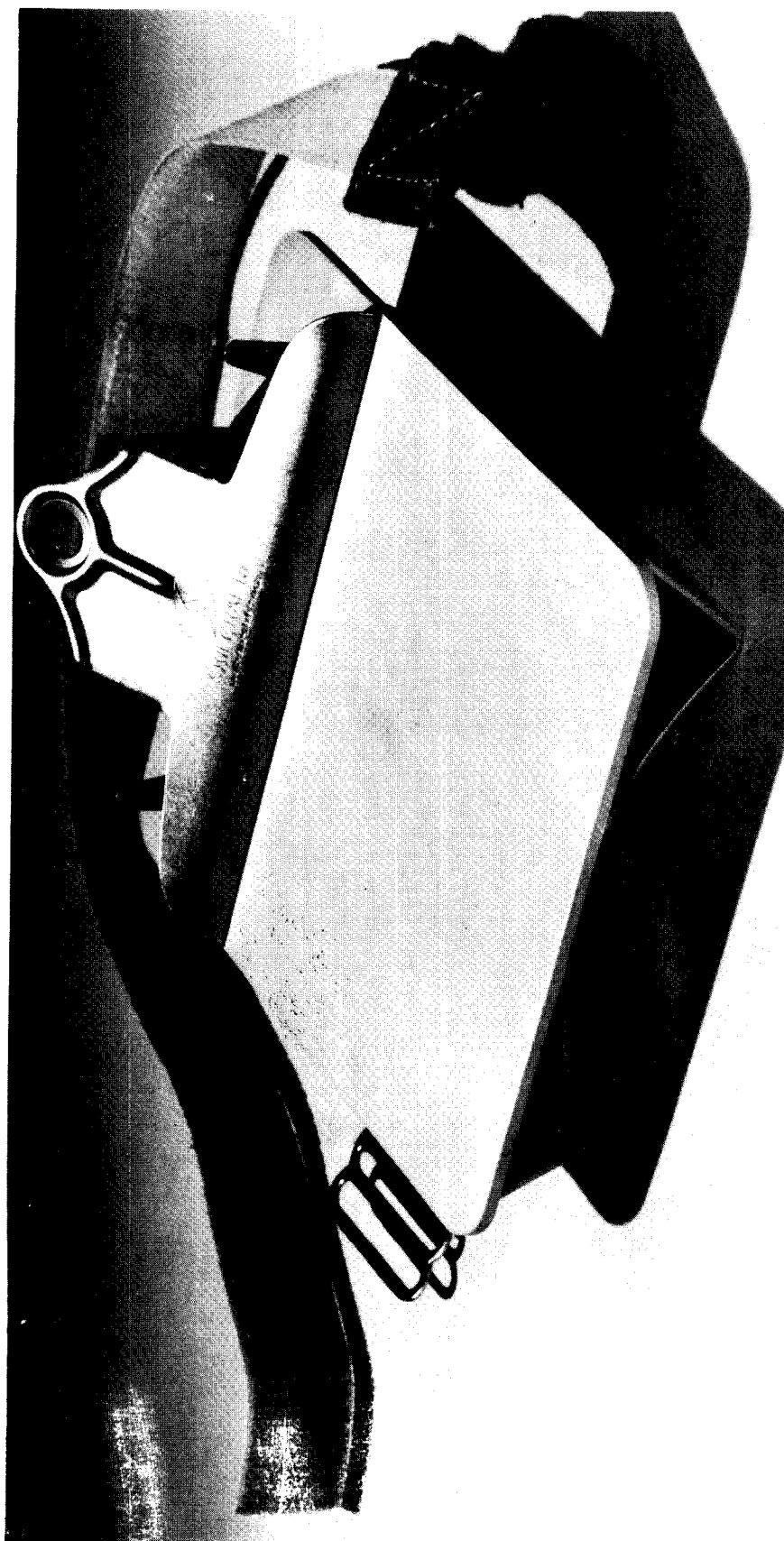

Figure 8.23-1 - Knee Board Assembly

8.23-2

B 8.24 Double Clipboard Assembly (SEC32100187)
Provides a hard backing (clipboard) to read one or two flight data file books or take notes as required.

B 8.24.1 Significant Configuration:

<u>Configuration</u>	<u>Purpose</u>
-301	Provide FDF book clipboard and writing table

B 8.24.2 Characteristics:

- Weight - 1.55 lbs. (704 gm.)
- Envelope - 14.3 x 10.8 x 4.3 in. (36.33 x 27.44 x 10.92 cm.)
- Volume - 664.1 in.³ (10.884 x 10³ cm.³)
- Fabricated at JSC.
- Qualified for Skylab use.

B

Figure 8.24-1 - Double Clipboard Assembly

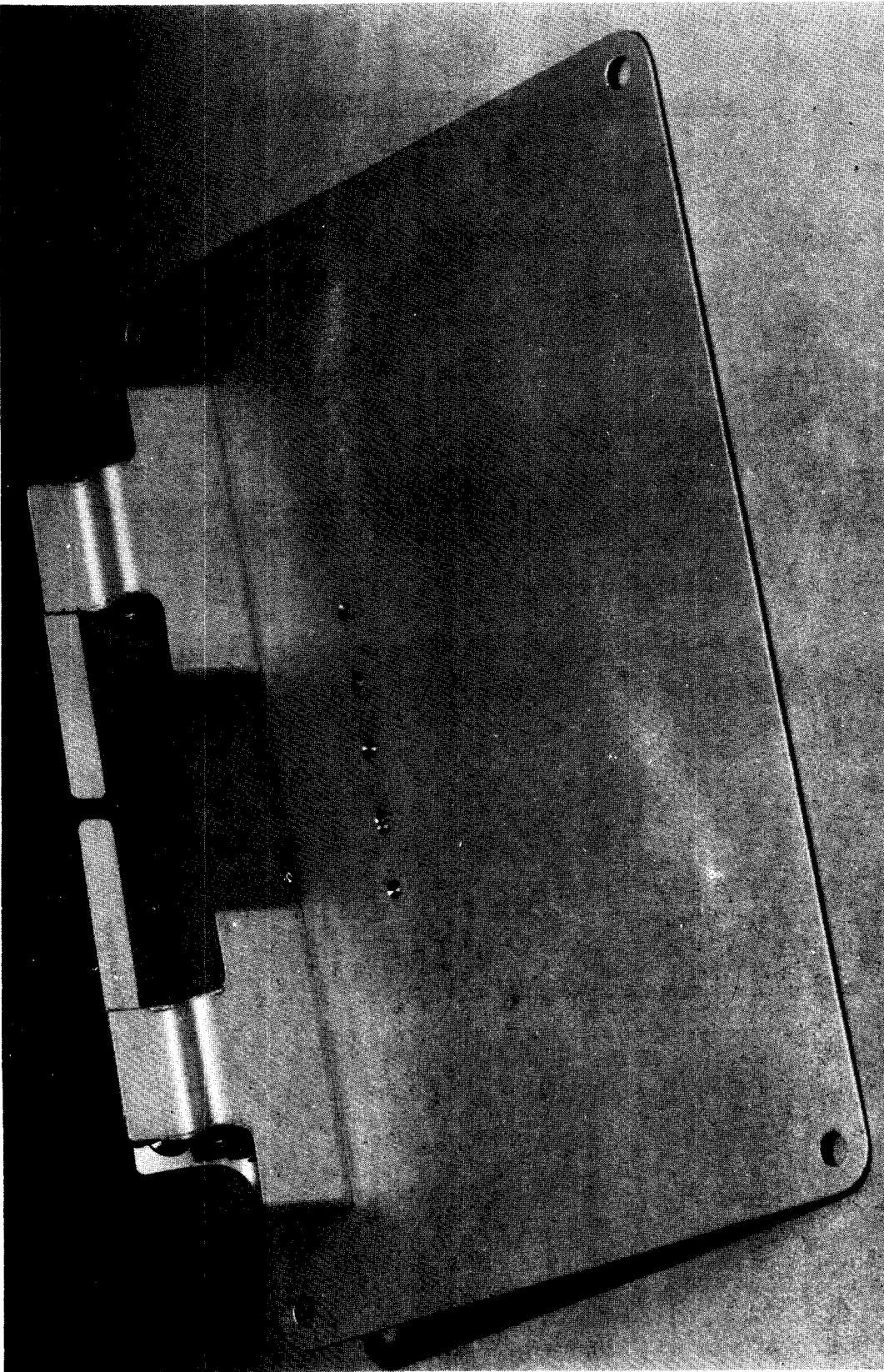

Figure 8.24-1 - Double Clipboard Assembly

8.24-2

B 8.25 Double Clip Assembly (SEC32100179)

The double clip is used to connect a Flight Data File Book to a grid bar on the OWS floor. Thus, a crewman can clip the reading material above his head on the grid floor at the position desired.

B 8.25.1 Significant Configuration:

<u>Configuration</u>	<u>Purpose</u>
-302	OWS unit

B 8.25.2 Characteristics:

•This item was manufactured by JSC TSD.

•Weight - .15 lbs. (68 gm.)
Envelope - 2.3 x 2.62 x 3.4 in. (5.84 x 6.7 x 8.64 cm.)
Volume - 20.5 in.³ (335.7 cm.³)

•This item interfaces with Flight Data File Book Assemblies and is qualified for use on Skylab (P/N SKB32100142-007).

B

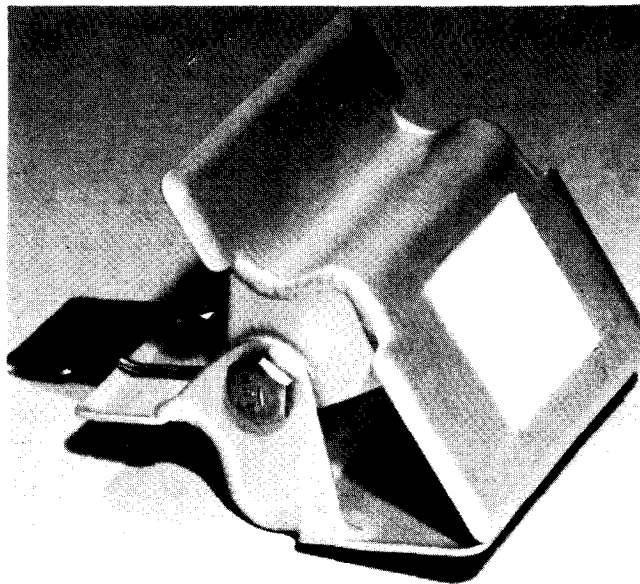

Figure 8.25-1 - Double Clip Assembly

B 8.26 Support Equipment Container Assembly (SEC33100923)

The JSC Support Equipment Container Assembly was designed to provide a stowage container to accommodate late program contingency equipment.

B 8.26.1 Significant Configuration:

<u>Configuration</u>	<u>Purpose</u>
----------------------	----------------

B 8.26.2 Characteristics:

- The container halves were procured from the Zero Manufacturing Co., Burbank, California 91503, and total assembly was configured by Flight Crew Integration Division, NASA, JSC .

- Weight - 5.0 lb. empty - 30 lb. max. loaded (2.3 kg.)
- Envelope - 9.18 x 10.043 x 10.898 in. (23 x 25.5 x 27.7 cm.)
- Volume - 1004.7 in.³ (16.46 x 10³ cm.³)

The JSC Support Equipment Container Assembly is qualified for use in the Skylab vehicles.

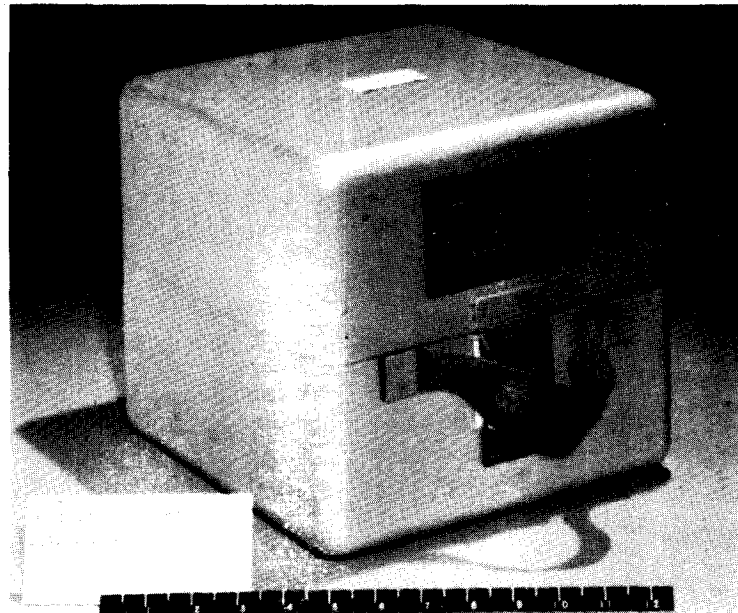

Figure 8.26-1 - Container

B 8.27 Book Tether Assembly (SEC32100180)

This tether is used to connect a flight data file book to a belt loop on the constant wear garment.

B 8.27.1 Significant Configuration:

<u>Configuration</u>	<u>Purpose</u>
-302	Skylab unit

B 8.27.2 Characteristics:

- Weight - .029 lbs. (13 gram)
- Envelope - .25 x 1.9 x 1.9 in. (.64 cm x 4.83 cm. x 4.83 cm)
- Volume - .91 in.³ (14.8 cm³)
- Fabricated at JSC.
- Qualified for use in Skylab.

B



Figure 8.27-1 - Book Tether

B 8.28 Skylab Earth Orbital Map (SEC32100153)

The Orbital Map is constructed of cardboard with roller assemblies riveted to the right and left sides, supporting an overlay showing the ground track.

B 8.28.1 Significant Configuration:

<u>Configuration</u>	<u>Purpose</u>
-302	Skylab (SL-1)

B 8.28.2 Characteristics:

.The Orbital Map with roller assemblies is fabricated at JSC.

•Weight - 1.25 lbs. (567 gm.)
Envelope - 19.50 x 19.00 x .19 in. (49.53 x 48.26 x .48 cm.)
Volume - 70.40 in.³ (1,147.35 cm.³)

•The flight path is photographically reproduced on a clear film band fitted over rollers to give an infinitely adjustable flight path indicator over points recognizable on the map.

•The Skylab Earth Orbital Map is qualified for use in Skylab vehicles.

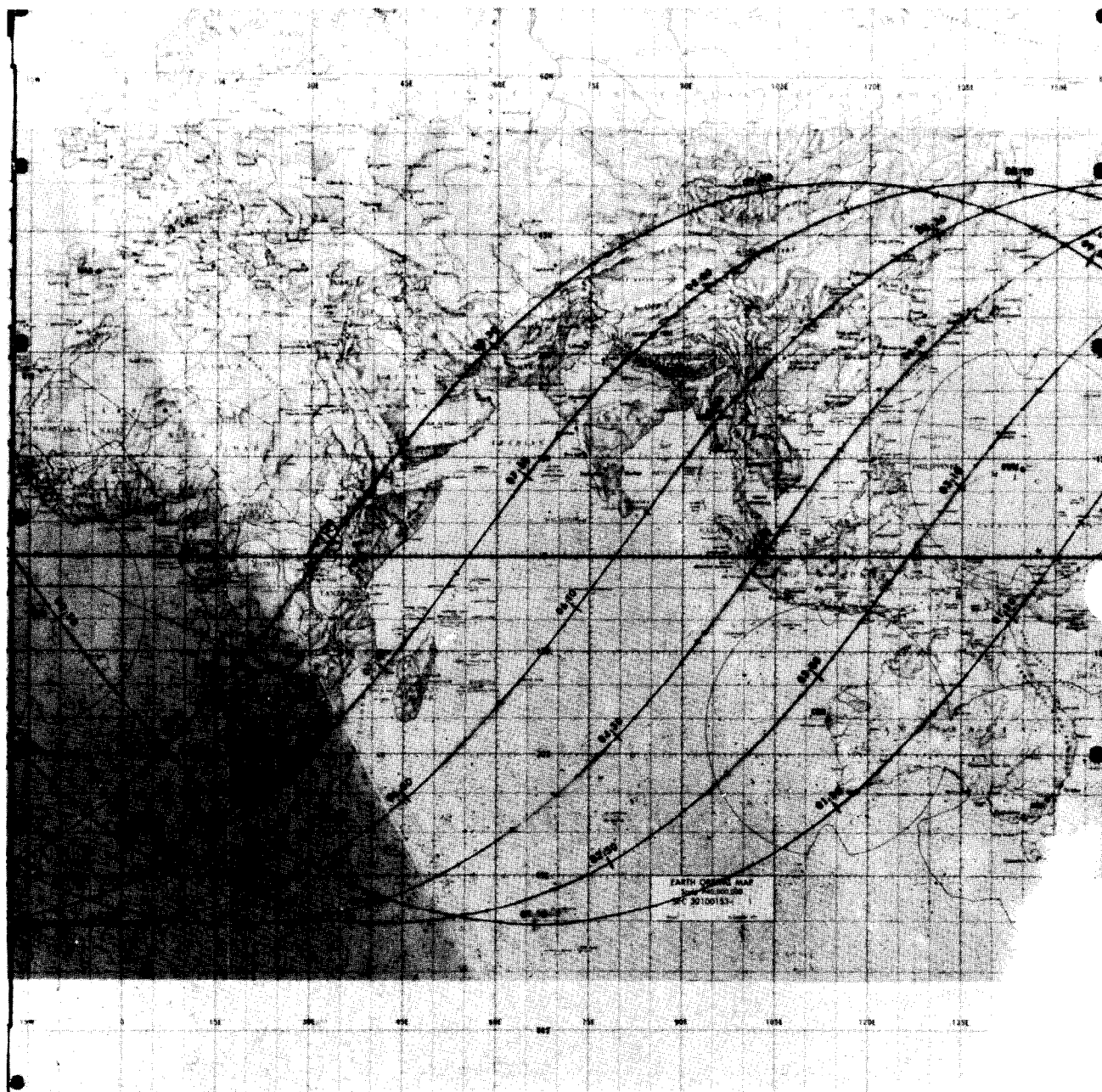

Figure 8.28-1 - Skylab Earth Orbital Map

8.28-2

B 8.29 United States Map Assembly (SEC32100161)

The U. S. Map Assembly is constructed of cardboard with roller assemblies riveted to the right and left sides, supporting an overlay showing the flight path over geological and elevation maps of the U. S.

B 8.29.1 Significant Configuration:

<u>Configuration</u>	<u>Purpose</u>
-301	Skylab (SL-1)

B 8.29.2 Characteristics:

•The U. S. Map Assembly was assembled by the Flight Data Section of Crew Procedures Division, with roller assemblies and drawings furnished by Crew Equipment and Design Branch.

•Weight - 0.87 lbs. (395 gm.)
Envelope - 20.93 x 11.88 x .19" (53.16 x 30.18 x 48 cm.)
Volume - 47.24 in.³ (770 cm.³)

•The flight path is photographically reproduced on a clear film band fitted over rollers to give an infinitely adjustable flight path indicator over points recognizable on the map.

•The U. S. Map Assembly is qualified for use in Skylab vehicles.

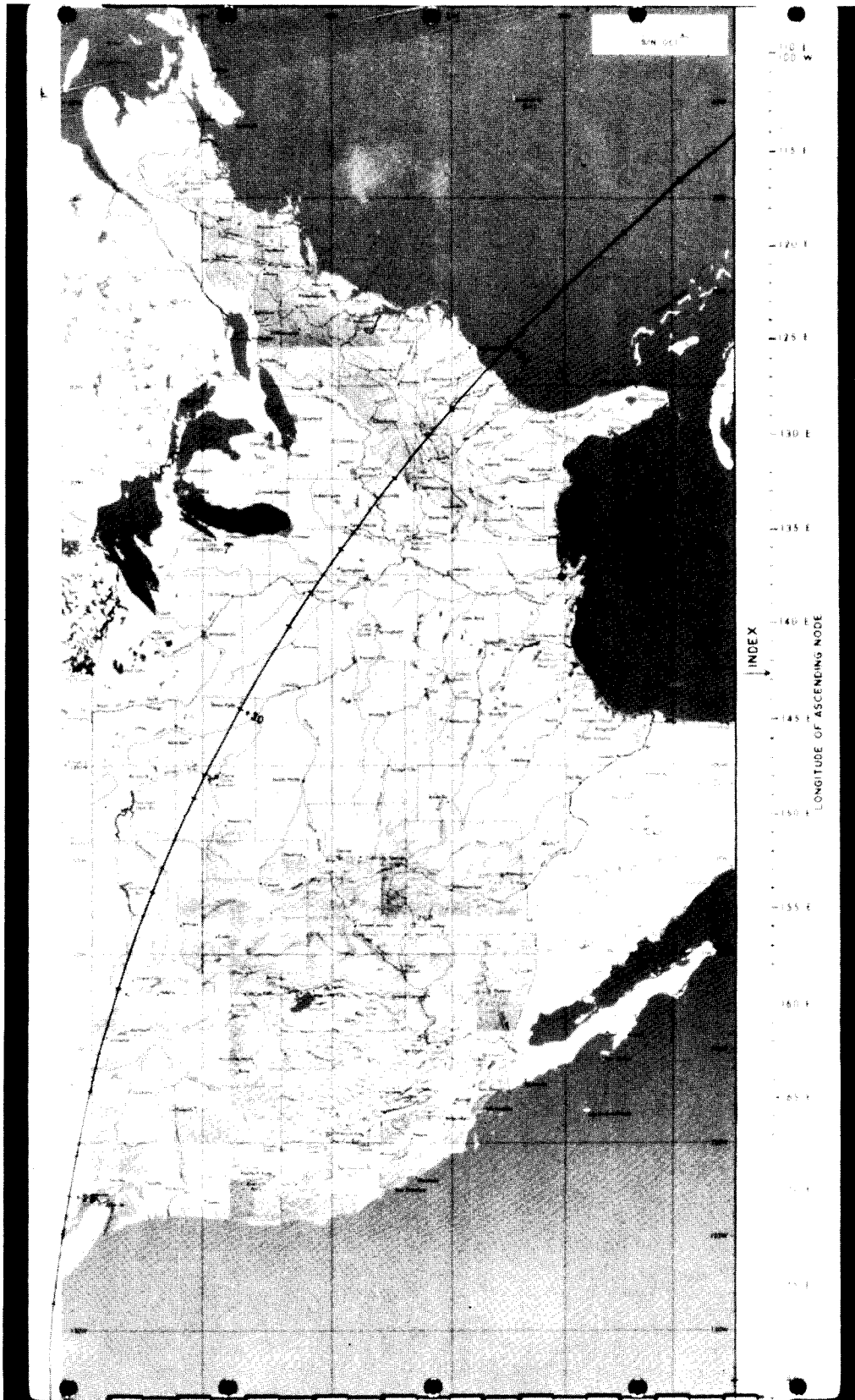

Figure 8.29-1 - United States Map

B 8.30 Large Data Card Kit (SEC32100162)

This is a large flag cloth bag which is used (analogous to a flat file) to stow the Earth Orbital Maps and the U. S. Map.

B 8.30.1 Significant Configuration:

<u>Configuration</u>	<u>Purpose</u>
-301	FDF map stowage bag

B 8.30.2 Characteristics:

- Weight - .49 lbs. (222 gm.)
- Envelope - 23 7/8 x 20 1/8 x 1.1 in. (70.8 cm. x 51.12 cm. x 2.8 cm.)
- Volume - 529 in.³ (8669 cm.³)
- Manufactured at JSC by CSD.
- Qualified for Skylab use.

B

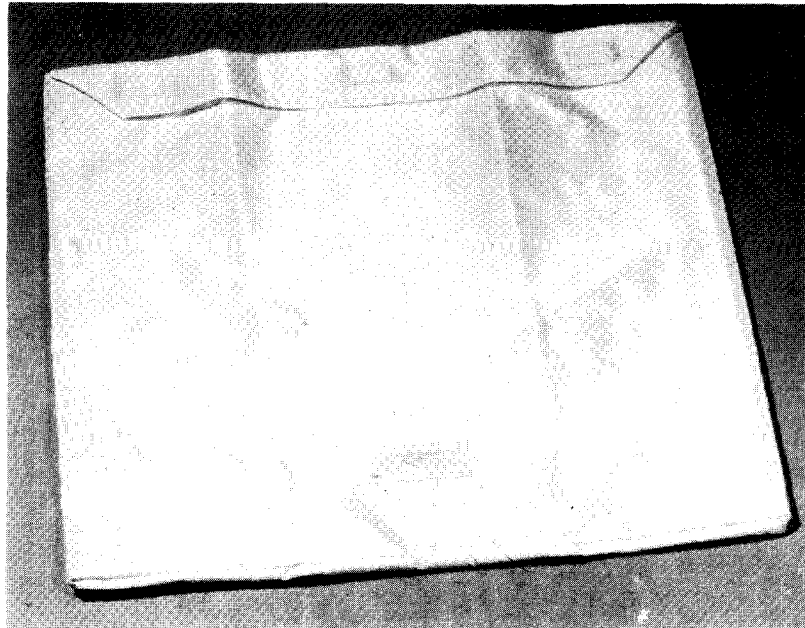

Figure 8.30-1 - Large Data Card Kit

B 8.31 Automatic Flash and Battery Assembly Bag (SEC33100943)

This bag is used to protect and stow the flash/battery assembly during launch.

B 8.31.1 Significant Configuration:

<u>Configuration</u>	<u>Purpose</u>
-301	Provide flash stowage

B 8.31.2 Characteristics:

- Weight - .71 lbs. (324 gm)
- Envelope - $7\frac{1}{4} \times 4\frac{1}{8} \times 3\frac{1}{2}$ in. (18.42 cm x 10.5 cm x 8.89 cm)
- Volume - 105 in.³ (1721 cm³)
- Manufactured by JSC in CSD.
- Qualified for Skylab use.

B 8.32 Bag Assembly for 35 mm. Camera Lens (SEC33100944)
This cloth bag provides a stowage bag for the 35 mm. lens.

B 8.32.1 Significant Configuration:

<u>Configuration</u>	<u>Purpose</u>
-301	Provide stowage for lens

B 8.32.2 Characteristics:

- Weight - .38 lbs. (173 gm.)
- Envelope - $3 \frac{3}{8} \times 3 \frac{3}{8} \times 3 \frac{7}{8}$ in. (8.6 x 8.6 x 9.8 cm.)
- Volume - 44.3 in.³ (725 cm.³)

•This item was manufactured at JSC by CSD and is qualified for use on Skylab.

B

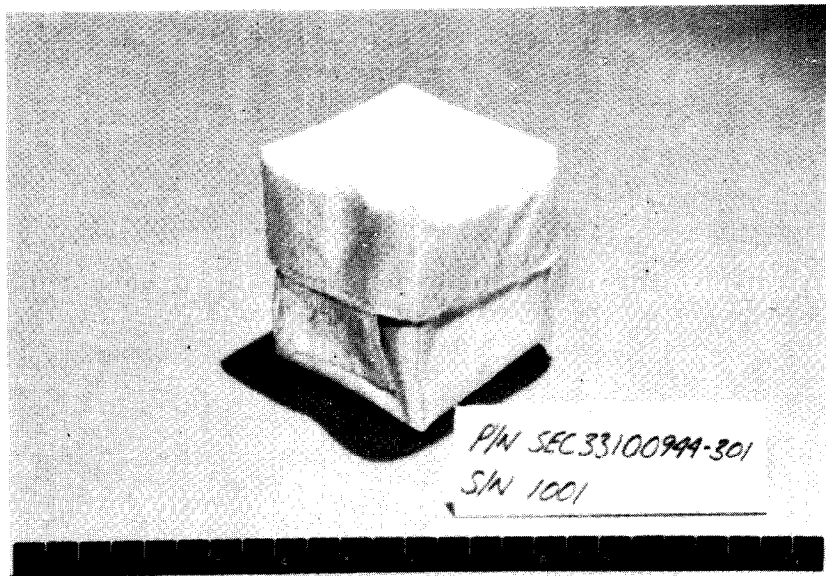

Figure 8.32-1 - Bag for 35 mm. Camera Lens

B 8.33 Teleprinter Message Book (SKC32100155)

A folding notebook arrangement that is used by the crew to take down teleprinter information. Fits into CW garment.

B 8.33.1 Significant Configuration:

<u>Configuration</u>	<u>Purpose</u>
-304	Notebook for Skylab
-305	Only difference is color
-306	

B 8.33.2 Characteristics:

- Weight - .39 lbs. (176 gm.)
- Envelope - 4.3 x 1.0 x 9.0 in. (11.0 x 2.54 x 22.9 cm.)
- Volume - 38.7 in.³ (634.2 cm.³)
- Fabricated at JSC by CSD.
- Qualified for Skylab.

B

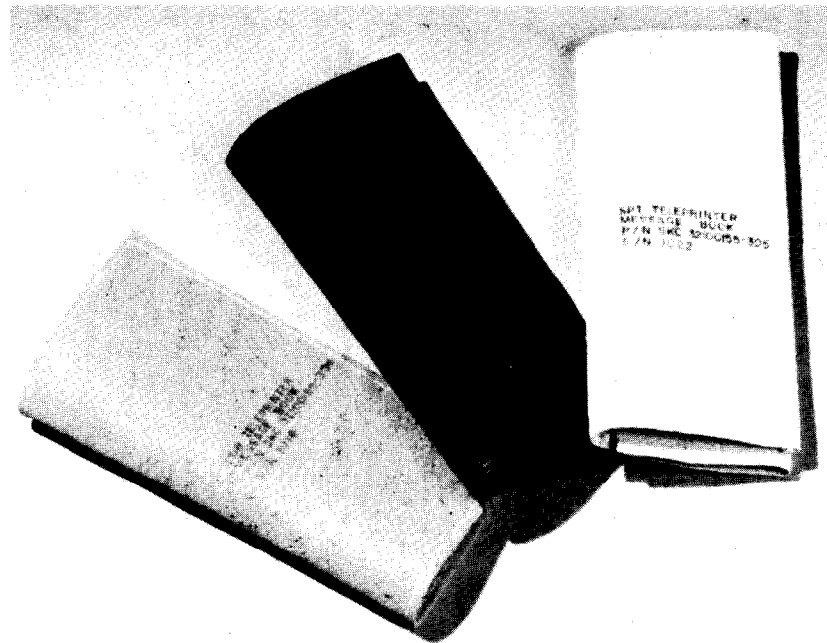

Figure 8.33-1 - Teleprinter Message Book

B 8.34 Flight Data File Book Back Assembly (SKB32100142)

The Flight Data File Book Back is used on the SKB32100142-302 book to give it rigidity for reading and writing. The rigidity eliminates the bending of the book when held at a single point, thus making it easy to read.

B 8.34.1 Significant Configuration:

<u>Configuration</u>	<u>Purpose</u>
-007	Stiffen book

B 8.34.2 Characteristics:

- This item was manufactured by JSC TSD.
- Weight - .55 lbs. (250 gm.)
- Envelope - 10.65 x 8.45 x .1 in. (27 x 21 x .25 cm.)
- Volume - 9 in.³ (145 cm.³)
- This item is qualified for use in Skylab.

B

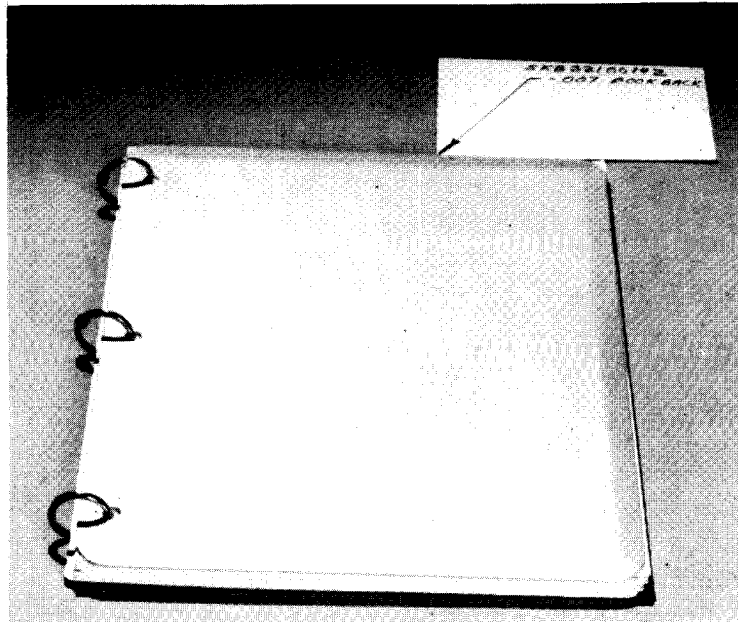

Figure 8.34-1 - Back for Flight Data File Book

B 8.35 Data Card Assembly Kit (SEB32100025)

These bags are used for multipurpose stowage. Detailed discussion is undertaken in the next paragraph.

B 8.35.1 Significant Configuration:

<u>Configuration</u>	<u>Purpose</u>
-304	Accessory stowage and teleprinter message book stowage
-305	Used as a CM/OWS transfer bag
-306	Used for on-orbit FDF book stowage

B 8.35.2 Characteristics:

-304

•Weight - .155 lb. (70.5 gm)
Envelope - 2 1/8 x 8 3/8 x 10 7/8 in. (5.4 cm. x 21.3 cm.
x 27.6 cm.)
Volume - 194 in.³ (3172 cm.³)

•Fabricated at JSC by CSD.

•Qualified for both Skylab and Apollo.

-305

•Weight - .155 lbs. (70.5 gm.)
Envelope - 2 1/8 x 10 7/8 x 8 3/8 in. (5.4 cm. x 21.3 cm.
x 27.6 cm.)
Volume - 194 in.³ (3172 cm.³)

•Fabricated at JSC by CSD.

•Qualified for both Skylab and Apollo.

-306

•Weight - .161 lbs. (73 gm.) empty
Volume - 2 1/8 x 8 3/8 x 10 7/8 in. (5.4 cm. x 21.3 cm. x
27.6 cm.)
Envelope - 194 in.³ (3172 cm.³)

•Fabricated at JSC by CSD.

•Qualified for both Skylab and Apollo

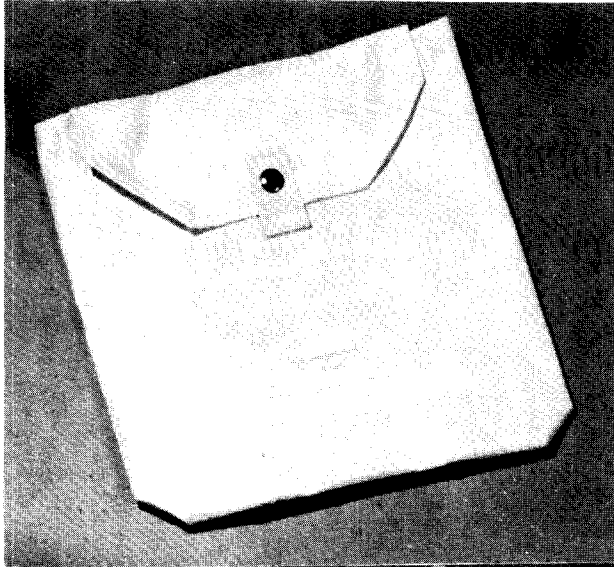

-304

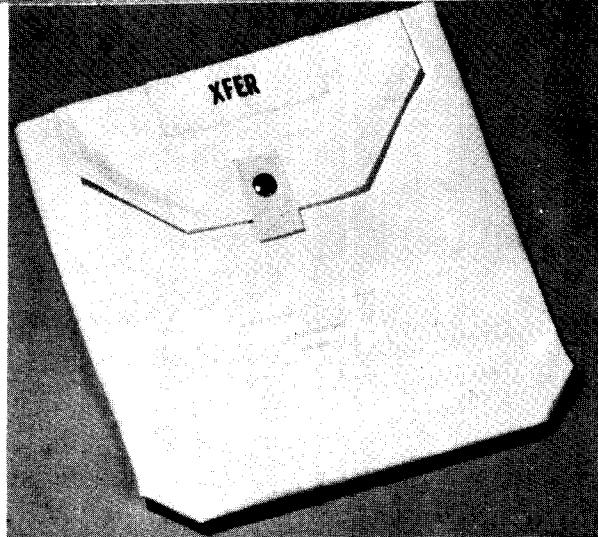

-305

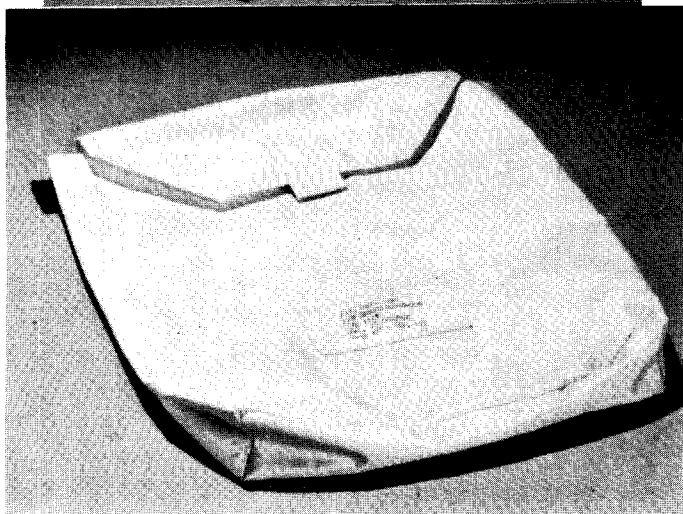

-306

Figure 8.35-1 - Data Card Assembly Kit

8.35-2

B 8.36 Data Card Kit Spring (SEB32100025)

The spring is used as a spiral binder to assemble various FDF checklists into notebooks. It is stowed in the Data Card Kit.

B 8.36.1 Significant Configuration:

<u>Configuration</u>	<u>Purpose</u>
-031	Form binder of checklists

B 8.36.2 Characteristics:

- This item is provided by JSC TSD.
- Weight - .002 lbs. (.91 gm)
- Envelope - 4.1 in. long x .41 dia. (10.4 m. long x 1.1 m. dia.)
- This item interfaces with -304 Data Card Kit components and is qualified for use on Skylab.

B

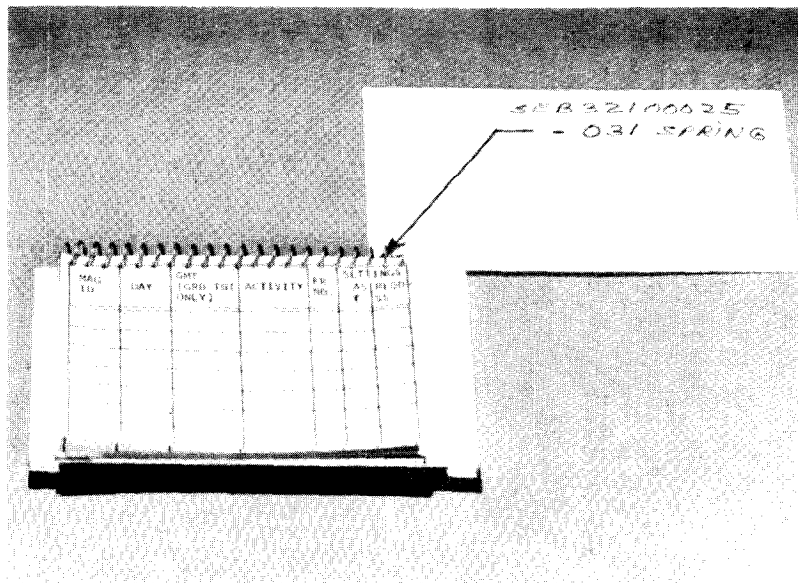

Figure 8.36-1 - Data Card Kit Spring

B 8.37 Tape Dispenser (SEB32100025)

The Tape Dispenser is an integral assembly similar to commercial dispensers. It contains Devoseal 12T transparent tape.

B 8.37.1 Significant Configuration:

<u>Configuration</u>	<u>Purpose</u>
-329	Skylab unit

B 8.37.2 Characteristics:

•Manufactured by TSD and FCID.

•Weight - .25 lbs. (113 gm.)

Envelope - 3.4 x 1.85 x 1.2 in. (8.6 x 4.7 x 3 cm.)

Volume - 7.5 in.³ (121 cm.³)

•Each Tape Dispenser contains approximately 75 ft. (22 m.) of 3/4 in. (1.9 cm.) wide Devoseal 12 T transparent tape.

•The -329 tape dispensers are qualified for use in the Skylab Flight Data File.

B

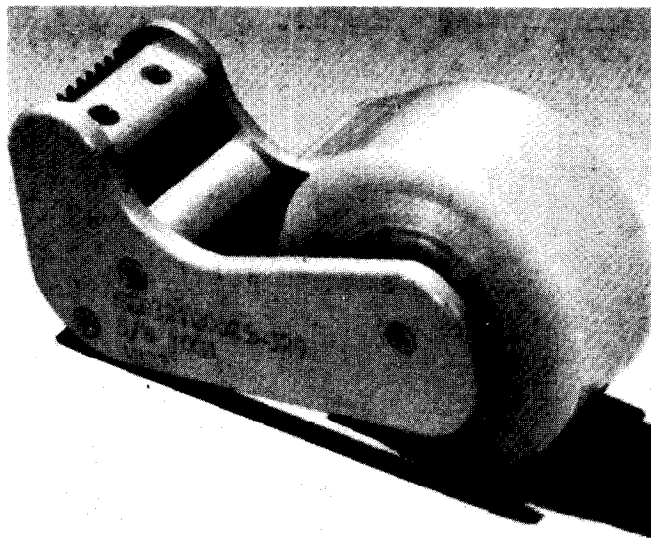

Figure 8.37-1 - Tape Dispenser

BIBLIOGRAPHY

1. "Apollo 16 Operational Cameras; Facts, Do's, Don'ts," CD42-A-978. NASA MSC, Flight Crew Integration Division, November 5, 1971.
2. "Apollo 17 Operational Cameras; Facts, Do's, Don'ts," CD42-A-980. NASA MSC, Flight Crew Integration Division, January 20, 1972.
3. J. D. Cooper and J. C. Abbott. "Nikon F, Nikkormat Handbook of Photography," Amphoto, New York, NY, 1968.
4. "Earth Terrain Camera - S190B Experiment Operation and Malfunction Procedures," Contract NAS 9-10818. Actron Industries, Inc., Monrovia, CA 91016; November 1, 1971.
5. H. Freytag. "The Hasselblad Way," Focal Press, New York, NY, 1968.
6. "Photo Equipment for Manned Space Flight Handbook." NASA MSC, Flight Crew Support Division, June 20, 1968.
7. "Photographic Equipment for Manned Space Flight Operational Photography." NASA MSC, Flight Crew Support Division (Released March 1967).
8. "Skylab Operational Cameras; Facts, Do's, Don'ts," CD42-SL-982. NASA MSC, Flight Crew Integration Division, February 15, 1972.
9. Specific Hardware Drawings. NASA MSC, Engineering Drawing Control Center, JM23, Houston, TX 77058.
10. R. E. Thompson, "A $2\frac{1}{4}$ by $2\frac{1}{4}$ Inch Photogrammetric Camera System for the Moon." New Horizons in Color Aerial Photography (Seminar Proceedings), SPSE, p. 175, June, 1969.
11. "Training Manual for 16 mm. Data Acquisition Camera System," CD42-SL-758. NASA MSC, Flight Crew Integration Division, March 1972.
12. Apollo Experience Report "Photographic Equipment and Operations During Manned Space Flight Programs" NASA TN MSC-05817, Helmut A. Kuehnle, MSC, December 1971.

