

~~CONFIDENTIAL~~

DOWNGRADED AT 3 YEAR INTERVALS:
DECLASSIFIED AFTER 12 YEARS
DOD DIR 5200.10

SINGLE COPY ONLY

MASSACHUSETTS INSTITUTE OF TECHNOLOGY

CLASSIFICATION CHANGE

To **UNCLASSIFIED**

By authority of S. Shirley Date 12/15/64
Changed by S. Shirley
Classified Document Master Control Station, NASA
Scientific and Technical Information Facility

APOLLO

GUIDANCE AND NAVIGATION

Approved: Milton B. Trageser Date: 12/15/64
MILTON B. TRAGESER, DIRECTOR
APOLLO GUIDANCE AND NAVIGATION PROGRAM

Approved: Roger B. Woodbury Date: 12/17/64
ROGER B. WOODBURY, DEPUTY DIRECTOR
INSTRUMENTATION LABORATORY

E-1142 (Rev. 27)
(UNCLASSIFIED TITLE)

SYSTEM STATUS REPORT

December 15, 1964



**INSTRUMENTATION
LABORATORY**

CAMBRIDGE 39, MASSACHUSETTS

COPY # 76 OF 145 COPIES
THIS DOCUMENT CONTAINS 46 PAGES

~~CONFIDENTIAL~~

~~CONFIDENTIAL~~

ACKNOWLEDGMENT

This report was prepared under DSR Project 55-191, sponsored by the Manned Spacecraft Center of the National Aeronautics and Space Administration through Contract NAS 9-153.

~~This document contains information affecting the national defense of the United States within the meaning of the Espionage Laws, Title 18, U.S.C., Sections 793 and 794, the transmission or the revelation of which in any manner to an unauthorized person is prohibited by law.~~

The publication of this report does not constitute approval by the National Aeronautics and Space Administration of the findings or the conclusions contained therein. It is published only for the exchange and stimulation of ideas.

LIST OF EFFECTIVE PAGES

Page Numbers

Title Page through vii

1-1

2-1 through 2-9

3-1 through 3-7

4-1 through 4-5

5-1 through 5-8

A-1

Distribution List

CONTENTS

Section		Page
1	INTRODUCTION	1-1
1-1	INTRODUCTION	1-1
1-2	ACCURACY	1-1
2	BLOCK I COMMAND MODULE DATA	2-1
2-1	WEIGHTS	2-1
2-1.1	WEIGHTS STATUS REPORTING.	2-1
2-1.2	CONTROL WEIGHT (ZERO SERIES)	2-1
2-1.3	DESIGN LOAD WEIGHT (ZERO SERIES)	2-1
2-2	REPORTED 100 SERIES WEIGHT CHANGES	2-1
2-2.1	CDU (+0.4 lb)	2-1
2-2.2	INTERCONNECTION ASSY (-5.0 lbs)	2-1
2-2.3	AGC (-3.0 lbs)	2-4
2-2.4	MDV (+1.9 lbs)	2-4
2-2.5	D&C/AGC LEB (+0.5 lb)	2-4
2-2.6	D&C/AGC MP (+0.5 lb)	2-4
2-3	BLOCK I (ZERO SERIES) WEIGHT, CENTER OF GRAVITY, AND MOMENT OF INERTIA DATA	2-4
2-4	COMMAND MODULE POWER REQUIREMENTS (100 SERIES)	2-5
2-5	STATUS OF COMMAND MODULE AGC PROGRAMS	2-5
3	BLOCK II COMMAND MODULE DATA	3-1
3-1	INTRODUCTION	3-1
3-2	RELIABILITY	3-1
3-3	WEIGHTS	3-1
3-4	REPORTED WEIGHT CHANGES	3-4
3-4.1	CDU (-3.0 lbs)	3-4
3-4.2	PSA (-9.6 lbs)	3-4
3-4.3	AGC (-8.0 lbs)	3-4
3-4.4	D&C/AGC LEB (-1.5 lbs)	3-4
3-4.5	D&C/AGC MP (-1.5 lbs)	3-4
3-5	POWER REQUIREMENTS	3-4

Section		Page
4	LUNAR EXCURSION MODULE DATA	4-1
4-1	INTRODUCTION	4-1
4-2	RELIABILITY	4-1
4-3	WEIGHTS FOR LEM	
4-4	REPORTED LEM WEIGHT CHANGES	4-3
4-4.1	CDU (-0.2 lb)	4-3
4-4.2	PSA (-8.0 lbs)	4-3
4-4.3	LGC (-8.0 lbs)	4-3
4-4.4	D&C/LGC (-1.5 lbs)	4-3
4-5	POWER REQUIREMENTS	4-3
5	GLOSSARY AND SYSTEM DEFINITION	5-1
Appendix A		A-1

ILLUSTRATIONS

Figure		Page
2-1	Electrical Load on Primary +28 VDC Power Supply for Block I (100 Series) Systems	2-6
3-1	Electrical Load on Primary +28 VDC Power Supply	3-5
4-1	Electrical Load on Primary +28 VDC Power Supply	4-4

TABLES

Table		Page
2-I	Current Weight Status of Block I (100 Series) Command Module	2-2
2-II	Block I (Zero Series) Weight and Balance Data	2-5
2-III	Nominal Power Dissipation (watts) vs G&N Activity for Block I (100 Series) Systems	2-7
2-IV	Block I (100 Series) Command Module Energy Consumption Profile for 12.85-Day Lunar Orbit Mission	2-8
2-V	Current Memory Estimates and the Status of Command Module AGC Programs	2-9
3-I	Reliability (as of 12/15/64)	3-1
3-II	Current Weight Status of Block II Command Module (lbs at 1 g)	3-2
3-III	Nominal Power Dissipation (watts) vs G&N Activity for Block II Systems	3-6
3-IV	Block II Command Module Energy Consumption Profile for 12.85-Day Lunar Orbit Mission	3-7
4-I	Reliability (as of 12/15/64)	4-1
4-II	Estimated Weights of LEM G&N Components (lbs at 1 g)	4-2
4-III	Lunar Excursion Module Power Profile Based on LEM ICD LIS-390-2	4-5

ABSTRACT

The System Status Report is distributed monthly on the 15th. This month's revision of E-1142 (Rev. 27) contains, in general, the following information for the Block I and Block II Command Module and Lunar Excursion Module equipment: configuration weights, centers of gravity, moments of inertia, power requirements, status of computer programs, and reliability values.

Section 1

INTRODUCTION

1-1 INTRODUCTION

The definition of what constitutes Block I, Block II, and LEM hardware is contained in the Glossary, section 5 of this report. In Block II and LEM the electronic CDU's, PSA, and AGC are now to return to the moisture-proofing concepts in practice before the hermetic sealing requirement was established.

The following information is included in this month's report:

- (1) Command Module, Block I
100 Series: Weights and power requirements
Zero Series: Total weight, centers of gravity, and moments of inertia
Guidance and Navigation Lunar Landing Mission: Status of Computer programs.
- (2) Command Module, Block II
Integrated Guidance, Navigation, and Control Configuration: Weights and reliability values.
- (3) Lunar Excursion Module
LEM Integrated Guidance and Control Configuration (Configuration "B."
Ref: Minutes of LEM Implementation Meeting No. 4): Weights and reliability values.

Also included is Appendix A which shows a comparison of the actual weights of the delivered G&N System No. 6 zero series equipment and the G&N 100 series equipment based on the latest weight estimates.

1-2 ACCURACY

The accuracy of numerical values reported in this revision should not be considered to be within the tolerances implied by the significant figures quoted. The reported values, although based upon the most current information, are subject to normal changes as design and development phases approach completion.

BLOCK I
COMMAND MODULE

Section 2

BLOCK I COMMAND MODULE DATA

2-1 WEIGHTS

Table 2-I presents the weights of all Block I flight (100 series systems) equipment, grouped according to specific location within the Command Module. Weights are reported to the component level and to the nearest tenth of a pound.

Given component weights are identified as estimated, calculated, and measured in order of increasing accuracy. These terms are defined by North American Aviation as follows: estimated weights (E) are based on rough calculations; calculated weights (C) are based on detailed calculations made from final production drawings that will be used to build flyable equipment; measured weights (M) are actual weights of equipment built to the production drawings.

North American Aviation will provide and be responsible for cold plate weights that are not integral with guidance and control equipment.

2-1.1 WEIGHTS STATUS REPORTING. Table 2-I also offers a comparison of present 100 series component weight values with those listed in System Status Report, E-1142 (Rev. 26), November 15, 1964. All weight changes are explained in paragraph 2-2.

2-1.2 CONTROL WEIGHT (ZERO SERIES). Column (a) in Table 2-I contains the February 15, 1964 weight status of Apollo G&N zero series equipment. Column (a) adds up to approximately the total control weight specified in letter PG-64-113 (March 6, 1964) from Mr. D. Gilbert, ASPO, Mr. M. Trageser, MIT/IL.

2-1.3 DESIGN LOAD WEIGHT (ZERO SERIES). At NASA Coordination Meeting No. 15A, MIT agreed to assign "not to exceed" design load weights for individual Block I G&N zero series subsystems. These weights were assigned by MIT in MIT letter AG 594-64, May 18, 1964, and are shown in column (d) of Table 2-I.

2-2 REPORTED 100 SERIES WEIGHT CHANGES

2-2.1 CDU (+0.4 lb). The increase in weight is due to the need for additional potting for moisture-proofing purposes.

2-2.2 INTERCONNECTION ASSY (-5.0 lbs). The decrease in weight results from a more precise calculation.

~~CONFIDENTIAL~~
BLOCK I
COMMAND MODULE

Table 2-I. Current Weight Status of Block I (100 Series) Command Module (lbs at 1 g)

Item	0 Series Status 2/64 (a)	(b-a)	100 Series Status 11/64 (b)	(c-b)	100 Series Status 12/64 (c)	Design Load Wt. 5/64 (d)+
<u>G&N SYSTEMS</u>						
CDU Assy	14.5 (M)	-0.9	13.6 (C)	+0.4	14.0 (E)	18.0
Optical Subsystem						
SXT	18.2 (C)	+0.5	18.7 (E)	0.0	18.7 (E)	100.0
SCT	13.8 (C)	+0.5	14.3 (E)	0.0	14.3 (E)	
Optical Base & Gearing	16.7 (E)	+0.3	17.0 (E)	0.0	17.0 (E)	
Optical Eyepieces						
SXT	1.3 (E)	+0.3	1.6 (C)	0.0	1.6 (C)	
SCT	2.3 (E)	+0.3	2.6 (C)	0.0	2.6 (C)	
NVB & Resilient Mounts	25.0 (E)	+0.7	25.7 (C)	0.0	25.7 (M)	
Bellows Assy	13.5 (M)	-0.8	12.7 (C)	0.0	12.7 (M)	
IMU	60.2 (M)	+0.3	60.5 (C)	0.0	60.5 (C)	65.0
Coolant Hoses (two)	1.0 (E)	-0.2	0.8 (E)	0.0	0.8 (E)	75.0
Power Servo Assy	59.4 (C)	+0.4	59.8 (C)	0.0	59.8 (C)	45.0
G&N Interconnection Assy	35.2 (E)	-5.2	30.0 (C)	-5.0	25.0 (E)	
G&N to S/C Interface Assy	8.0 (E)	+5.0	83.0 (E)	-3.0	80.0 (E)	100.0
AGC (no spares)	70.0 (E)	-0.4	3.1 (E)	0.0	3.1 (E)	4.5
Optical Shroud	3.5 (M)					
<u>LOWER EQUIPMENT BAY</u>						
<u>D&C</u>						
D&C Electronics	2.9 (M)	+0.1	3.0 (E)	0.0	3.0 (E)	70.0
Control Electronics	2.9 (E)	-0.8	2.1 (E)	0.0	2.1 (E)	
G&N Ind Cont Panel	9.5 (M)	+1.0	10.5 (E)	0.0	10.5 (E)	
IMU Control Panel	2.4 (M)	+0.4	2.8 (E)	0.0	2.8 (E)	
MDV (includes 1 film)	7.7 (C)	+1.9	9.6 (C)	+1.9	11.5 (E)	
D&C/AGC	20.6 (M)	+0.8	21.4 (C)	+0.5	21.9 (C)	
Horizon. Photo. Elect.	0.0	+2.2	2.2 (C)	0.0	2.2 (C)	0.0
Signal Conditioner Assy	0.0	+3.9	3.9 (C)	0.0	3.9 (C)	8.0

~~CONFIDENTIAL~~
BLOCK I
COMMAND MODULE

Table 2-I. Current Weight Status of Block I (100 Series) Command Module (lbs at 1 g) (cont)

Item	0 Series Status 2/64 (a)	(b-a)	100 Series Status 11/64 (b)	(c-b)	100 Series Status 12/64 (c)	Design Load Wt. 5/64 (d)†
<u>MAIN PANEL AREA</u> D&C/AGC	20.5 (M)	+0.9	21.4 (C)	+0.5	21.9 (C)	26.0
<u>LOOSE STORED ITEMS</u>						
Eye Relief Eyepieces	1.5 (E)	0.0	1.5 (E)	0.0	1.5 (E)	3.0
Film Cartridges (4)	2.4 (E)	+0.1	2.5 (C)	0.0	2.5 (C)	5.0
Optics	1.7 (M)	-0.1	1.6 (C)	0.0	1.6 (C)	2.5
TOTAL	415.0*	+11.2	425.9	-4.7	421.2	522.0

*Total control weight specified in letter PG-64-114 (March 6, 1964) from Mr. D. Gilbert, ASPO, to Mr. M. Trageser, MIT/IL. See paragraph 2-1.2. Applies to zero series only.

†Design Load Weights are taken from MIT letter AG 594-64 (May 18, 1964). See paragraph 2-1.3. Applies to zero series only.

BLOCK I COMMAND MODULE

2-2.3 AGC (-3.0 lbs). A more detailed calculation is now possible. The measured weight of the 104B computer without the three rope sticks, rope cores, tray potting, and module potting was 69.0 lbs. It is estimated that these items weigh an additional 11.0 lbs. The total weight for the computer plus the above items is estimated to be 80.0 lbs.

2-2.4 MDV (+1.9 lbs). The total weight increase is the result of moisture sealing of the equipment reported below.

2-2.4.1 Optics Subsystem (+1.4 lbs). A welded one-piece sheet metal enclosure for the projection light system has been added. Passage of air from within to without and vice versa is permitted by a pressure-balancing valve. The characteristics of the valve are such that the internal to external pressure differential will never exceed 1 psi.

All the elements of the condenser system will be contained in a one-piece sealed lens housing capable of withstanding pressure, negative or positive, of 15 psi maximum.

2-2.4.2 The Electronics Package (+0.4 lb). The electronics package weight increase is due to the incorporation of waterproof connectors.

2-2.4.3 Lamp and Socket Unit (+0.1 lb). Moisture-proofing of the lamp socket and the interface of the lamp with the socket will be accomplished in the following manner: The socket will be a one-piece drawn cup with leads potted into its base. The interface moisture seal will be especially designed rubber compression grommet sealing the flange of the lamp base with the flanged mouth of the lamp.

2-2.5 D&C/AGC LEB (+0.5 lb). The increase in weight is due to the need for additional potting for moisture-proofing purposes.

2-2.6 D&C, AGC MP (+0.5 lb). The increase in weight is due to the need for additional potting for moisture-proofing purposes.

2-3 BLOCK I (ZERO SERIES) WEIGHT, CENTER OF GRAVITY, AND MOMENT OF INERTIA DATA

Block I (100 series) center of gravity and moment of inertia information is unavailable at this time, but is under preparation.

Included for reference are the total Block I (zero series) weight, center of gravity, and moment of inertia values.

~~CONFIDENTIAL~~
BLOCK I
COMMAND MODULE

Table 2-II. Block I (Zero Series) Weight and Balance Data

Weight (lb)	Center of Gravity (in)		Moments of Inertia* (lb-in ²)	
408.9	X	55.1	Ixx	681,030
	Y	-0.3	Iyy	1,939,064
	Z	37.3	Izz	1,308,074

*Values determined with respect to the basic X, Y, Z axes of the Command Module.

2-4 COMMAND MODULE POWER REQUIREMENTS (100 SERIES)

The power requirements of the Command Module G&N 100 series equipment on the primary +28 VDC power supply are shown in figure 2-1 which presents the magnitude and location of dissipated power values on a subassembly level. This chart assumes a 12.85-day lunar mission, as defined by S&ID for power profile computation, and is based on 28 VDC input at the connectors. The values shown are average values. (Ref: S&ID letter 63 MA 3540.)

Table 2-III shows the magnitude and location of power dissipation for the established G&N activities, each of which consists of various power levels of operation.

Table 2-IV shows the energy requirements for each G&N activity on a power level basis. The table is based upon MIT letter AG 679-6, "G&N Power Profile Status," dated August 14, 1963. The vertical column to the left indicates the various G&N activities (phases of operation) for the model 12.85-day mission submitted by S&ID in S&ID letter 64 MA 3540. The column also indicates the power requirement and operating time for each specific activity. The top row indicates the power requirement and operating time for each G&N power consuming equipment. The table sums up the energy consumption for each G&N activity and each G&N power consuming equipment.

2-5 STATUS OF COMMAND MODULE AGC PROGRAMS

The integrated guidance and control implementation activity has defined stabilization and control functions which must be part of the Block II computer program. Since the current program estimates do not include these S&C functions, the computer program status has been moved from section 3 to section 2 where it applies to the Block I configuration used for a lunar mission but without S&C. When the computer estimates include these added functions, the AGC program status will be returned to section 3.

BLOCK I COMMAND MODULE

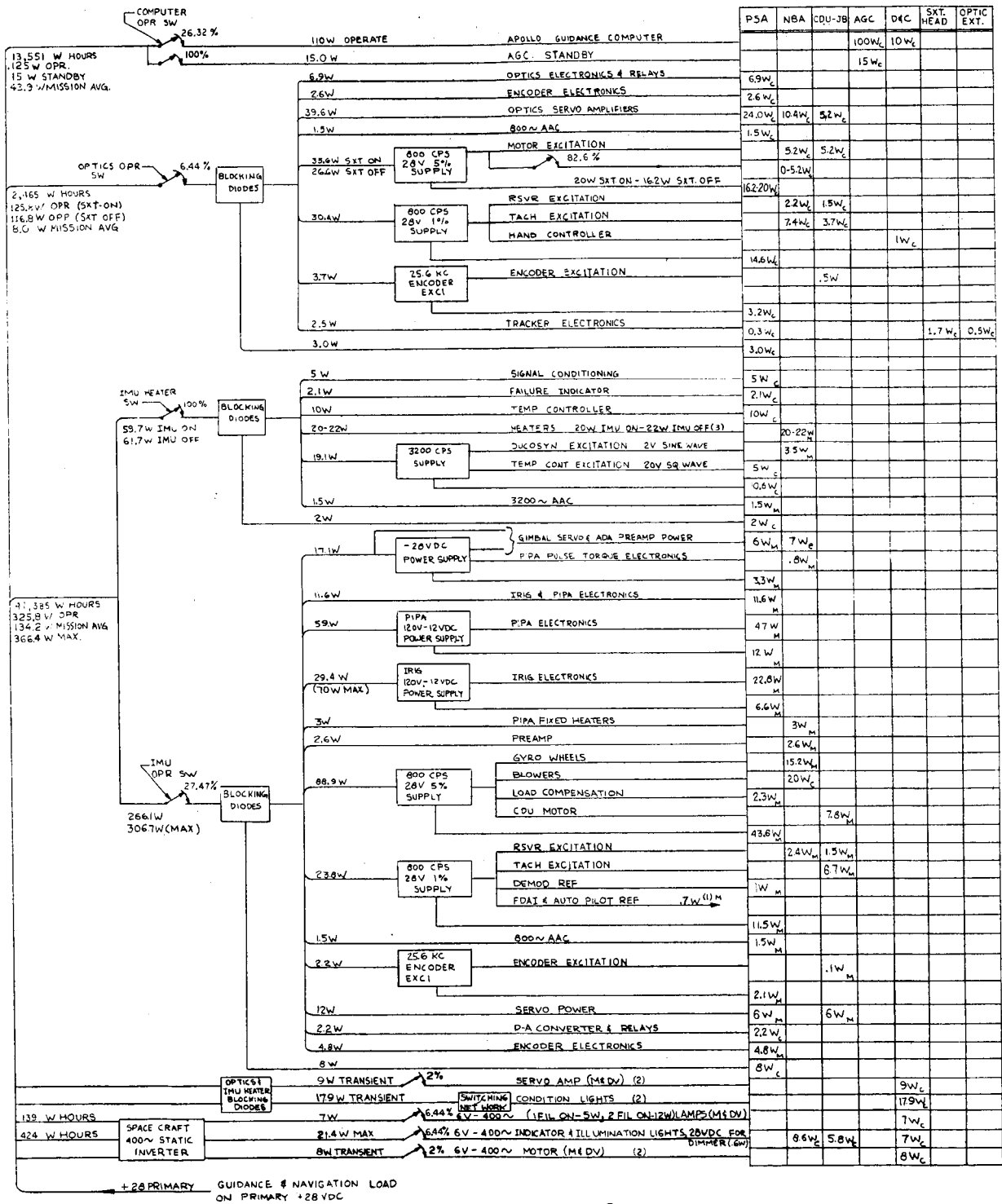

Figure 2-1. Electrical Load on Primary +28 VDC Power Supply
Block I (100 Series) Systems

BLOCK I COMMAND MODULE

Table 2-III. Nominal Power Dissipation (watts) vs G&N Activity for Block I (100 Series) Systems

M O D E	G&N Activity (power levels)	NBA		CDU JB	PSA		AGC	Thermal Load on S/C Coolant	D&C and S&C	Optics External	Electrical Load
		IMU	OBA		IMU	OBA					
A	A accomplish & Confirm Course Corrections Inactivity and Monitor Major Maneuver (1, 5)	74.5	0.0	22.1	228.5	0.0	115.0	440.1	10.7	0.0	450.8
B	Alignments Sextant Sightings (1, 3, 5, 7)	74.5	40.7	44.0	228.5	76.1	115.0	578.8	25.7	0.5	605.0
C	Landmark Trackings (Low-Orbit Navigation) (1, 4, 5, 7)	74.5	35.5	44.0	228.5	72.3	115.0	569.8	25.7	0.5	596.0
D	Star Occultation Sightings (1, 6)	25.5	0.0	0.0	36.2	0.0	115.0	176.7	10.0	0.0	186.7
E	Sextant Sightings Midcourse Navigation (1, 3, 6, 7)	25.5	40.7	21.9	36.2	76.1	115.0	315.4	25.0	0.5	340.9
F	Inactivity & Monitor (2, 6)	25.5	0.0	0.0	36.2	0.0	15.0	76.7	0.0	0.0	76.7
G	Inactivity & Monitor (2, 5)	74.5	0.0	22.1	228.5	0.0	15.0	340.1	0.7	0.0	340.8

- | | |
|---|--|
| <ol style="list-style-type: none"> 1. AGC Operate 2. AGC Standby 3. Optics Operate SXT ON 4. Optics Operate SXT OFF 5. IMU Operate 6. IMU Standby 7. D&C Operate | <ol style="list-style-type: none"> 125.0 watts 15.0 watts 125.8 watts 116.8 watts 325.8 watts 61.7 watts 28.4 watts |
|---|--|

BLOCK I COMMAND MODULE

Table 2-IV. Block I (100 Series) Command Module Energy Consumption Profile for 12.85-Day Lunar Orbit Mission

M O D E	G&N Activity	(1) AGC Operate 125.0 watts 81.15 hours	(2) AGC Standby 15.0 watts 227.13 hours	(3) Optics Sextant ON 125.8 watts 16.39 hours	(4) Optics Sextant OFF 116.8 watts 3.45 hours	(5) IMU Operate 325.8 watts 84.68 hours	(6) IMU Standby 61.7 watts 223.60 hours	(7) D&C Operate 28.4 watts 19.84 hours	Total
A	Accomplish & Confirm Course Corrections Inactivity and Monitor Major Maneuvers 450.8 watts 58.41 hours	7.301	-	-	-	19.030	-	-	26.331
B	Alignments Sextant Sightings 605.0 watts 13.73 hours	1.716	-	1.727	-	4.473	-	0.390	8.306
C	Landmark Trackings (Low-Orbit Navigation) 596.0 watts 3.45 hours	0.431	-	-	0.403	1.124	-	0.098	2.056
D	Star Occultation Sightings 186.7 watts 2.90 hours	0.363	-	-	-	-	0.179	-	0.542
E	Sextant Sightings (Midcourse Navigation) 340.9 watts 2.66 hours	0.333	-	0.335	-	-	0.164	0.076	0.907
F	Inactivity and Monitor 76.7 watts 218.04 hours	-	3.271	-	-	-	13.453	-	16.724
G	Inactivity and Monitor 340.8 watts 9.09 hours	-	0.136	-	-	2.962	-	-	3.098
	Total 308.30 hours	10.144	3.407	2.062	0.403	27.569	13.796	0.563	57.964

BLOCK I
COMMAND MODULE

Table 2-V lists current Command Module memory estimates and the status of AGC programs for the lunar landing mission guidance and navigation functions.

A high and low word estimate is given with each program. Each status is defined as follows:

- (1) Planning stage
- (2) Programming stage
- (3) Checkout on AGC simulation
- (4) Checkout on G&N simulation
- (5) Checkout on AGC

Table 2-V. Current Memory Estimates and the Status
of Command Module AGC Programs (12/15/64)

Item	Status	Memory Estimate (words)	
		High	Low
List Processing Interpreter	(5)	1712	1712
AGC Executive	(5)	253	253
AGC Waitlister	(5)	145	145
AGC System Exerciser	(5)	500*	294*
G&N System Exerciser	(4)	650	400
Display, Keyboard, and Telemetry	(5)	2000	2000
Input/Output Control	(5)	1750*	1275*
Midcourse & Orbital Navigation	(5)	2000*	1500*
Midcourse & Orbital Guidance	(3)	500	500
Pre-Launch Platform Alignment	(5)	400*	350*
In-Flight Platform Alignment	(4)	1024	900
Re-Entry Control	(4)	1800	1200
Injection and De-Boost	(4)	1000	400
Restart	(5)	500*	200*
Aim-Point Determination & Abort	(3)	4000	2000
Totals		18234	13129

*Programs in stage (5) whose low and high estimates are not identical reflect an anticipated increase in computation facility.

~~CONFIDENTIAL~~
BLOCK II
COMMAND MODULE

Section 3

BLOCK II COMMAND MODULE DATA

3-1 INTRODUCTION

On September 23, 1964, MIT was directed to hermetically package all electronic components in the Command Module as the basic approach for humidity and contaminant protection. During the period of changing to hermetic sealing, MSC assessed the consequences and now has directed MIT to return to the conformal moisture-proofing of the CDU's, PSA, and the AGC.

3-2 RELIABILITY

The reliability figures shown in Table 3-I are the current estimates of the Block II Command Module G&N equipment. They reflect the realignment of the interface configuration which requires the G&N equipment to assume certain stabilization and control functions, the elimination of the standby guidance computer, and the most recent estimate of electronic CDU reliability. These estimates of Command Module G&N reliability are based on the 138-hour mission defined in the Lunar Landing Mission Design Plan.

Table 3-I. Reliability (as of 12/15/64)

Subsystem	Operation Time (hrs) Full Power	Probability of Mission Success
IMU	31	0.9961
AGC	19*	0.9869
DSKY	19	0.99999
PSA	31*	0.99421
CDU (5)	31	0.9923
Optics	18	0.99804
Total G&N System		0.9679

*Certain assemblies function continuously.

3-3 WEIGHTS

Table 3-II shows the weights of the Block II Command Module Integrated Guidance and Control system.

~~CONFIDENTIAL~~
BLOCK II
COMMAND MODULE

Table 3-II. Current Weight Status of Block II Command Module (lbs at 1 g)

	Status 2/64 (a)	(b-a)	Status 11/64 (b)	(c-b)	Status 12/64 (c)	Design Load Wt. 5/64 (d)
<u>G&N SYSTEMS</u>						
CDU Assy	15.0 (E)	+21.0	36.0 (C)	-3.0	33.0 (E)	
Optical Subsystem						
SXT	18.2 (C)	+ 0.5	18.7 (E)	0.0	18.7 (E)	
SCT	13.8 (C)	+ 0.5	14.3 (E)	0.0	14.3 (E)	
Optical Base & Gearing	16.7 (E)	+ 0.3	17.0 (E)	0.0	17.0 (E)	
Optical Eyepieces						
SXT	1.3 (E)	+ 0.3	1.6 (E)	0.0	1.6 (E)	
SCT	2.3 (E)	+ 0.3	2.6 (E)	0.0	2.6 (E)	
NVB & Mounts	22.0 (E)	- 5.0	17.0 (E)	0.0	17.0 (E)	
Bellows Assy	13.5 (C)	- 0.8	12.7 (E)	0.0	12.7 (E)	
IMU	42.0 (E)	+ 0.1	42.1 (E)	0.0	42.1 (E)	
Coolant Hoses (two)	1.0 (E)	- 0.2	0.8 (E)	0.0	0.8 (E)	
Power Servo Assy*	45.1 (E)	+ 9.6	54.7 (E)	-9.6	45.1 (E)	
G&N Interconnection Assy	35.2 (E)	- 4.2	31.0 (E)	0.0	31.0 (E)	
G&N to S/C Interface Assy	8.0 (E)	+ 0.5	8.5 (E)	0.0	8.5 (E)	
AGC	92.5 (E)	-26.5	66.0 (E)	-8.0	58.0 (E)	
Optical Shroud	3.5 (C)	- 0.4	3.1 (E)	0.0	3.1 (E)	
<u>LOWER EQUIPMENT BAY</u>						
<u>D&C</u>						
D&C Electronics	1.5 (E)	0.0	1.5 (E)	0.0	1.5 (E)	
Control Electronics	2.9 (E)	- 0.9	2.0 (E)	0.0	2.0 (E)	
G&N Ind Cont Panel	11.1 (E)	+ 1.0	12.1 (E)	0.0	12.1 (E)	
MDV (including 1 film cartridge)	8.3 (E)	+ 3.2	11.5 (E)	0.0	11.5 (E)	
D&C/AGC	20.6 (E)	- 1.6	19.0 (E)	-1.5	17.5 (E)	
Signal Conditioner Assy	0.0	+ 3.9	3.9 (C)	0.0	3.9 (C)	

(cont)

~~CONFIDENTIAL~~
BLOCK II
COMMAND MODULE

Table 3-II. Current Weight Status of Block II Command Module (lbs at 1 g) (cont)

Item	Status 2/64 (a)	(b-a)	Status 11/64 (b)	(c-b)	Status 12/64 (c)	Design Load Wt. 5/64 (d)
<u>MAIN PANEL AREA</u> D&C/AGC	20.5 (E)	- 1.5	19.0 (E)	- 1.5	17.5 (E)	
<u>LOOSE STORED ITEMS</u> Eye Relief Eyepieces	1.5 (E)	0.0	1.5 (E)	0.0	1.5 (E)	
Film Cartridges (4)	1.8 (E)	+ 0.7	2.5 (E)	0.0	2.5 (E)	
Optics Cover	1.7 (E)	- 0.1	1.6 (C)	0.0	1.6 (C)	
TOTAL	400.0†	+ 0.7	400.7	-23.6	377.1	492.6§

*Includes the weight of the PSA Cover.

† Control Weight specified in letter (PG-64-113, March 6, 1964) from Mr. D. Gilbert, ASPO, to Mr. M. Trageser, MIT/IL. See paragraph 2-1.2.

§ Design Load Weight taken from S&ID letter 63 MA 2032, February 11, 1964. Does not include loose stored items.

BLOCK II
COMMAND MODULE

3-4 REPORTED WEIGHT CHANGES

3-4.1 CDU (-3.0 lbs). The weight decrease is a result of the return to the previously established moisture-proofing of the CDU package. The weight did not revert to the original estimate because of a more refined calculation of the final layout.

3-4.2 PSA (-9.6 lbs). The weight decrease is a result of the return to the conformal moisture-proofing of the PSA package. This weight includes the PSA cover.

3-4.3 AGC (-8.0 lbs). The weight decrease is a result of the return to the conformal moisture-proofing of the AGC.

3-4.4 D&C/AGC LEB (-1.5 lbs). The weight decrease is a result of a more detailed calculation of the hermetically sealed design configuration.

3-4.5 D&C/AGC MP (-1.5 lbs). The weight decrease is a result of a more detailed calculation of the hermetically sealed design configuration.

3-5 POWER REQUIREMENTS

The power requirements of the Block II Command Module G&N equipment on the primary +28 VDC power supply are shown in figure 3-1, which presents the magnitude and location of dissipated power values on a subassembly level. This chart assumes a 12.85-day lunar orbit mission as defined by S&ID for power profile computation and is based on 28 VDC input at the connectors. These values are average values. (Ref: S&ID letter 64 MA 3540.)

Table 3-III shows the magnitude and location of power dissipation for the established G&N activities, each of which consists of various power levels of operation.

Table 3-IV shows the energy requirements for each G&N activity on a power level basis. The table is based on MIT letter AG 679-6, "G&N Power Profile Status," dated August 14, 1963. The vertical column to the left indicates the various G&N activities (phases of operation) for the model 12.85-lunar day mission submitted by S&ID in S&ID letter 64 MA 3540. This column also indicates the power requirements and operating time for each specific activity. The top row indicates the power requirements and operating time of each G&N power consuming equipment. The total power consumption for each G&N activity and each G&N power consuming equipment is also given.

BLOCK II COMMAND MODULE

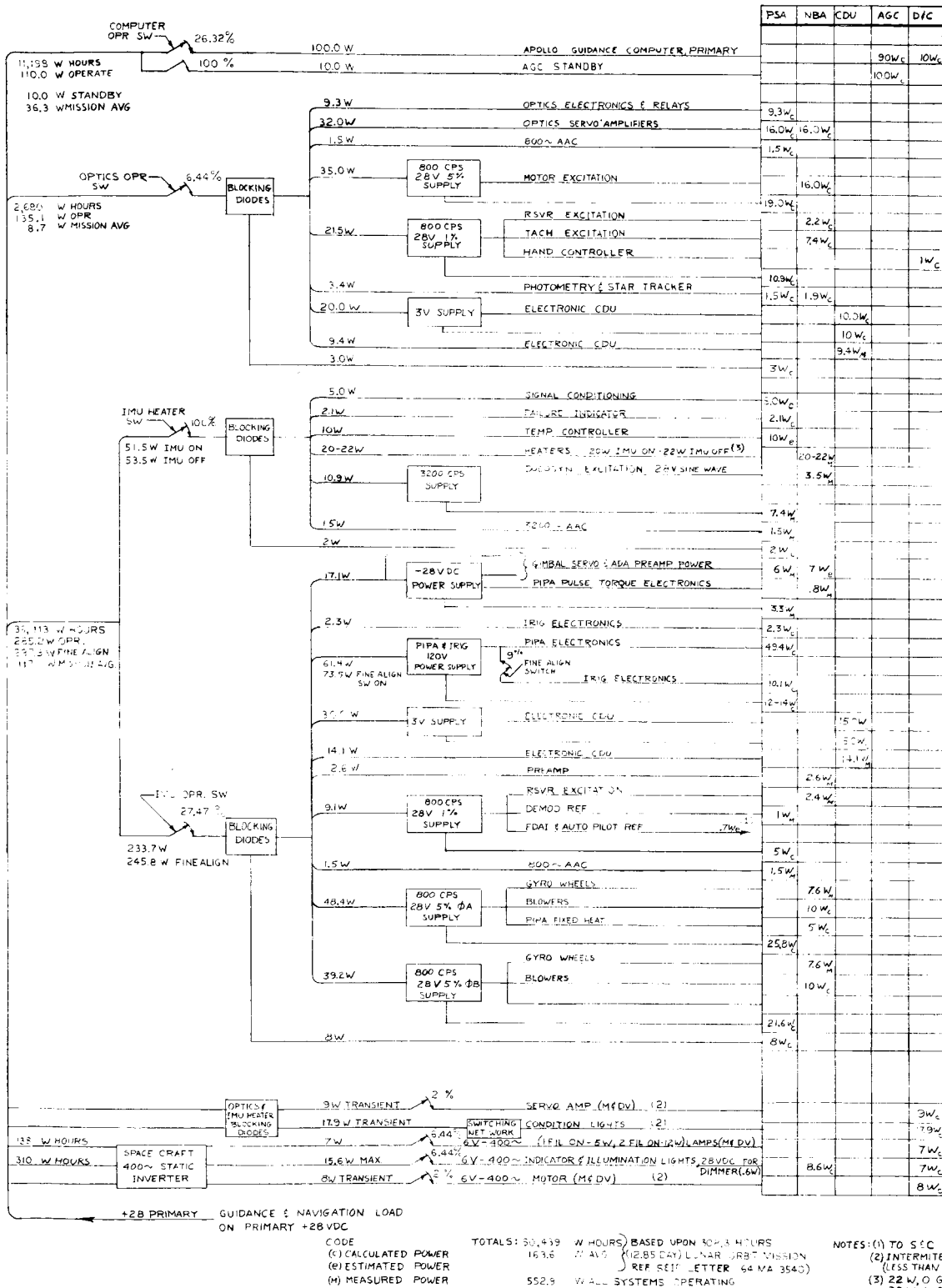

Figure 3-1. Electrical Load on Primary +28 VDC Power Supply

BLOCK II COMMAND MODULE

Table 3-III. Nominal Power Dissipation (watts) vs G&N Activity for Block II Systems

M O D E	G&N Activity (power levels)	NBA		CDU	PSA		AGC	Thermal Load on S/C Coolant	D&C and S&C	Electrical Load
		IMU	OBA		IMU	OBA				
A	Accomplish & Confirm Course Corrections Major Maneuvers Inactivity & Monitor (1, 4)	76.5	0.0	44.1	163.9	0.0	100.0	384.5	10.7	395.2
B	Alignments Sextant Sightings Landmark Trackings (Low-orbit navigation) (1, 3, 4, 6)	76.5	52.1	73.5	163.9	61.2	100.0	527.2	25.7	552.9
C	Star Occultation Sightings (1, 5)	25.5	0.0	0.0	28.0	0.0	100.0	153.5	10.0	163.5
D	Sextant Sightings (Midcourse Navigation) (1, 3, 5, 6)	25.5	52.1	29.4	28.0	61.2	100.0	296.7	25.0	321.2
E	Inactivity & Monitor (2, 5)	25.5	0.0	0.0	28.0	0.0	10.0	63.5	0.0	63.5
F	Inactivity & Monitor (2, 4)	76.5	0.0	44.1	163.9	0.0	10.0	294.5	0.7	295.2

- | | |
|---|---|
| <ol style="list-style-type: none"> 1. AGC Operate 2. AGC Standby 3. Optics Operate 4. IMU Operate 5. IMU Standby 6. D&C Operate | <ol style="list-style-type: none"> 110 watts 10 watts 135.1 watts 285.2 watts 53.5 watts 22.6 watts |
|---|---|

BLOCK II COMMAND MODULE

Table 3-IV. Block II Command Module Energy Consumption Profile for 12.85-Day Lunar Orbit Mission

Operating Mode	G&N Activity	Energy Consumption (kwh)						Total
		(1) AGC Operate 110.0 watts 81.15 hours	(2) AGC Standby 10.0 watts 227.13 hours	(3) Optics Operate 135.1 watts 19.84 hours	(4) IMU Operate 285.2 watts 84.68 hours	(5) IMU Standby 53.5 watts 223.60 hours	(6) D&C Operate 23.6 watts 19.84 hours	
A	Accomplish & Confirm Course Corrections Major Maneuvers Inactivity & Monitor 395.2 watts 58.41 hours	6.425	—	—	16.659	—	—	23.084
B	Alignments Sextant Sightings Landmark Trackings (Low-orbit Navigation) 552.9 watts 17.18 hours	1.890	—	2.321	4.900	—	0.388	9.499
C	Star Occultation Sightings 163.5 watts 2.90 hours	0.319	—	—	—	0.155	—	0.474
D	Sextant Sightings (Midcourse Navigation) 321.2 watts 2.66 hours	0.293	—	0.359	—	0.142	0.060	0.854
E	Inactivity & Monitor 63.5 watts 218.04 hours	—	2.180	—	—	11.665	—	13.845
F	Inactivity & Monitor 295.2 watts 9.09 hours	—	0.091	—	2.592	—	—	2.683
	Total 308.30 hours	8.927	2.271	2.680	24.151	11.962	0.448	50.439

LUNAR EXCURSION MODULE

Section 4

LUNAR EXCURSION MODULE DATA

4-1 INTRODUCTION

Because of the possibility of the requirement for hermetic sealing in the LEM as a result of the rule for common usage in the CM and LEM vehicle, last month's issue reported hermetic packaged weights for the CDU's, PSA, LGC, and the LGC Display and Control. Continuing with this common usage rule, the CDU's, PSA, and LGC will now conform to the previously existing moisture-proofing method. (For further explanation, see paragraph 3-1.)

4-2 RELIABILITY

There have been no significant changes in the G&N equipment design this month that would warrant a re-evaluation of the reliability figures presented in the last month's report. Table 4-I presents the latest figures.

The LEM G&N reliability values are based on a mission of the same duration as the CM G&N equipment.

Table 4-I. Reliability (as of 12/15/64)

Subsystem	Operating Time (hrs)	Probability of Mission Success
IMU	6.25	0.99914
LGC	6.25	0.9976
PSA	6.25	0.99928
CDU (5)	6.25	0.99822
OMU	0.75	0.99997
DSKY	6.25	0.9976
Total G&N System		0.9918

4-3 WEIGHTS FOR LEM

Lunar Excursion Module weights are presented in Table 4-II. In general the data conform to the information contained in paragraphs 2-1, 2-1.1, and 2-1.2.

The row labeled "Bare Guidance System" is inserted to provide for comparisons with similarly specified systems.

~~CONFIDENTIAL~~

LUNAR EXCURSION MODULE

Table 4-II. Estimated Weights of LEM G&N Components (lbs at 1 g)

Item	Status 2/64 (a)	(b-a)	Status 11/64 (b)	(b-a)	Status 12/64 (c)	Design Load Wt. 7/64 (d)
CDU's	15.0 (E)	+18.2	33.2 (E)	-0.2	33.0 (E)	*
Telescope and All Eyepieces	24.5 (E)	+ 1.0	25.5 (E)	0.0	25.5 (E)	
Landing Point Designator	2.0 (E)	0.0	2.0 (E)	0.0	2.0 (E)	
IMU	42.0 (E)	+ 0.1	42.1 (E)	0.0	42.1 (E)	
LGC/PSA Interconnection Assy	10.0 (E)	0.0	10.0 (E)	0.0	10.0 (E)	
LGC Display and Controls	19.5 (E)	- 0.5	19.0 (E)	-1.5	17.5 (E)	
Book of Procedures, etc.	2.0 (E)	0.0	2.0 (E)	0.0	2.0 (E)	
LGC	45.8 (E)	+20.2	66.0 (E)	-8.0	58.0 (E)	
PSA†	27.2 (E)	8.0	35.2 (E)	-8.0	27.2 (E)	
NVB	0.0	+ 6.0	6.0 (E)	0.0	6.0 (E)	
Total	210.0§ Control Weight	+53.0	241.0	-17.7	223.3	
Bare Guidance System (IMU, PSA, and LGC)	110.7	+28.3	143.3	-16.0	127.3	

*No design load weight has been assigned.

† Includes the weight of the PSA Cover.

§ Control Weight specified in Letter PG-64-113 (March 6, 1964) from Mr. D. Gilbert, ASPO, to Mr. M. Trageser, MIT/IL. See section 2-1.2.

~~CONFIDENTIAL~~

LUNAR EXCURSION MODULE

4-4 REPORTED LEM WEIGHT CHANGES

4-4.1 CDU (-0.2 lb). Last month's report neglected to include the weight increase due to the incorporation of the guidance and control functions as part of the CDU subsystem. Therefore the weight decrease due to the return to previously existing moisture-proofing method will not conform with the Block II CDU decrease.

4-4.2 PSA (-8.0 lbs). The weight decrease is a result of the return to the conformal moisture-proofing of the PSA. This weight includes the PSA cover.

4-4.3 LGC (-8.0 lbs). The weight decrease is a result of the return to the conformal moisture-proofing of the AGC.

4-4.4 D&C/LGC (-1.5 lbs). The weight decrease is a result of a more detailed calculation of the hermetically sealed design configuration.

4-5 POWER REQUIREMENTS

The estimate for LEM power and energy consumption shown in figure 4-1 is based upon Command Module G&N Block II Data and Preliminary ICD LIS-390-2, LEM Electrical Load Analysis Form.

Table 4-III shows the energy requirements for each G&N activity on a power level basis. The table is also based upon LEM ICD LIS-390-2. The vertical column on the left indicates the various G&N activities (phases of operation). This column also indicates the power requirements and operating time for each activity. The top row indicates the power requirements and operating time of each G&N power consuming equipment. The table sums up the energy consumption for power consuming equipment.

LUNAR EXCURSION MODULE

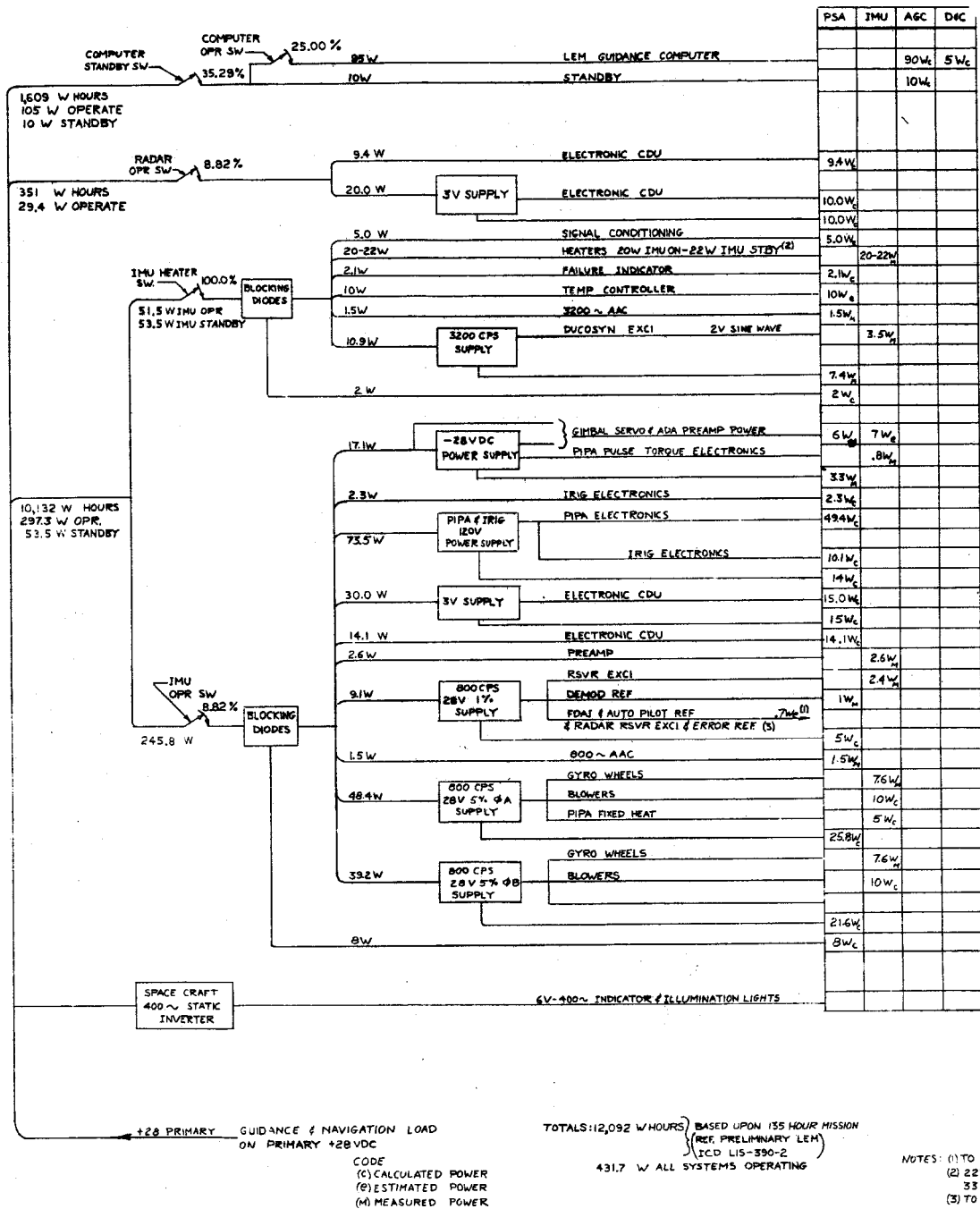

Figure 4-1. Electrical Load on Primary +28 VDC Power Supply

LUNAR EXCURSION MODULE

Table 4-III. Lunar Excursion Module Power Profile Based on LEM ICD LIS-390-2

		Energy Consumption (kwh)							
M O D E	LEM G&N Activity	(1) LGC Off 0.0 watts 87.40 hours	(2) LGC. Operate 105.0 watts 11.92 hours	(3) LGC Standby 10.0 watts 35.75 hours	(4) IMU Operate 297.3 watts 11.92 hours	(5) IMU Standby 53.5 watts 123.15 hours	(6) Two Radar CDU Operate 29.4 watts 11.92 hours	(7) OMU (AOT) Operate Negligible watts 27.42 hours	Total
I	Inactivity 53.5 watts 87.40 hours	0.000	—	—	—	4.676	—	—	4.676
II	Inactivity Alignment Midcourse Measurements 431.7 watts 11.72 hours	—	1.231	—	3.484	—	0.345	negligible	5.060
III	Guidance During Major Event 431.7 watts 0.20 hours	—	0.021	—	0.059	—	0.006	—	0.086
IV	Inactivity 63.5 watts 20.05 hours	—	—	0.200	—	1.073	—	—	1.273
V	Inactivity 63.5 watts 15.70 hours	—	—	0.157	—	0.840	—	negligible	0.997
	Total 135.07 hours	0.000	1.252	0.357	3.543	6.589	0.351	negligible	12.092

Section 5

GLOSSARY AND SYSTEM DEFINITION

Apollo Guidance Computer (AGC)

CM BLOCK I A single complete flight computer containing all logic, memory, associated power supplies, and all interface circuits except those identified with the CDU's. Does not contain the associated displays and controls.

Consists of one case containing factory replaceable electronic modules. Includes cover for moisture-proofing, but does not include the necessary cold plate or the G&N to S/C Interface Assembly which is located in the adjacent area.

CM BLOCK II AND LEM Same as Block I except that associated power supplies are in a separate case and the CDU's are either adjacent to or on the opposite side of the same cold plate as the AGC. Memory capacity is increased over Block I.

Alignment Optical Telescope (AOT)

CM BLOCK I AND BLOCK II Not in CM: see Optical Subsystem.

LEM A 3-position periscope with single-degree-of-freedom manually read reticule for alignment of the IMU. Includes the weight of the bellows assembly, a long-eye-relief eyepiece, and regular eyepiece.

Bellows Assembly

CM BLOCK I AND CM BLOCK II Two flexible pressure seals between CM structure and optical subsystem for penetration of pressure hull with optics.

LEM One bellows with a double convoluted wall and two seals providing a flexible seal for pressure penetration of the AOT in the spacecraft. This weight is included in the AOT value.

Book of Procedures

CM Not in CM; see MDV.

LEM Book or other form of maps, charts, procedures, instructions, and the like, needed for lunar operations.

Coupling Data Unit (CDU) Assembly

The CDU provides the necessary signal interfaces among the IMU gimbal angles, optics gimbal angles, radar gimbal angles, angle registers in the AGC, the spacecraft autopilot attitude error signals, and the tracking radar command error signals.

CM BLOCK I Five interchangeable gear boxes each with necessary motor tachometer, resolver synchros, and encoder with mounting frame work. Does not include associated electronics which are located in the PSA.

CM BLOCK II Functionally identical to Block I except the instrumentation is all electronic. Includes all support electronics (including special power supply) and header. Changes in resolver synchro characteristics and mode controls make Block I and II CDU's noninterchangeable.

LEM Interchangeable with CM Block II CDU's except for the headers.

Cold Plates

CM BLOCK I, BLOCK II, AND LEM Cold plates for the IMU are built into the IMU. Necessary cold plates for electronics are part of the equipment supplied by the spacecraft manufacturer. All surfaces over glycol coolant passages and open to the cabin environment will be insulated to prevent moisture condensation.

Control Electronics Assembly

CM BLOCK I Consists of one power transformer, one relay and diode module, and a bracket end connector. Used to support display and control functions. Includes moisture-proofing.

CM BLOCK II May be relocated with other similar functions.

LEM Not defined in LEM.

Coolant Hoses

CM BLOCK I AND CM BLOCK II Consists of (1) two steel flex coolant hoses, one between IMU and spacecraft and one between optics and spacecraft, (2) bracket assembly screws and clamp, and (3) entrapped coolant.

LEM Not identified as part of LEM.

Display and Control/Apollo Guidance Computer (D&C/AGC)

CM BLOCK I Number displays and keyboard control associated with the operation of the AGC. Two functionally identical and parallel operating units: one in lower equipment bay and one on main panel between left and center couches.

CM BLOCK II Mechanically and electrically identical to Block I but smaller configuration because of smaller relays. The Block II display and keyboard controls will be hermetically sealed by encasing the unit in a container.

LEM Identical to Block II except only a single unit is required.

D&C Electronics Assembly

CM BLOCK I Consists of a chassis, a relay and diode module, a demod. elect. module, a saturable reactor, a time delay module, a connector, and wiring. Used to support display and control functions. Connectors will be moisture-proofed.

CM BLOCK II Not defined at this time.

LEM Not defined in LEM at this time.

Landing Point Designator

CM Not in CM

LEM An optical sighting device consisting of a reticle, plane mirror, collimating lens, and a beam splitter to magnify the target area with a light-line reticle pattern.

Film Cartridges

CM BLOCK I AND BLOCK II Consists of film cartridges and film for map and data viewer.

LEM Does not exist in LEM.

G&N Indicator Control Panel

CM BLOCK I AND BLOCK II Consists primarily of controls and displays for the operation of the optics, MDV, IMU temperature control, panel brightness control, and attitude impulse control. It includes display and control elements, panel, panel wiring, supporting hardware, and moisture-proofing.

LEM Does not exist in LEM.

G&N Interconnection Assembly

CM BLOCK I Consists of PSA End Connector Assembly and interconnect wiring harness, which electrically ties together the assemblies that constitute a completely integrated system. This term does not include weights of harness support brackets, which are an NAA responsibility, or the G&N to S/C Interface Assembly weight.

CM BLOCK II Similar to Block I but not interchangeable. The connectors in the upper harness are now to be sealed against moisture and contamination.

LEM Not clearly defined but at present is called the AGC/PSA Interconnection Assy. Because of the wide separation of G&N components, most interconnection will be accomplished as part of spacecraft wiring.

G&N to S/C Interface Assembly

CM BLOCK I Cable interconnections between the spacecraft wiring channel, the computer connector, and the PSA end connector. Contains no active electronics.

CM BLOCK II Similar in functions to Block I except the configuration is much different and not interchangeable with Block I. The connectors in the lower harness are now to be sealed against moisture and contamination.

LEM Not identified yet as a separate item in LEM.

Horizon Photometer

CM BLOCK I AND BLOCK II An earth horizon brightness photometer and automatic star tracker used for navigation measurements against the earth's illuminated limb. The sensors are incorporated into the head of the SXT the weight of which includes this function. The PSA includes all support electronics for Block II and some of the support electronics for Block I.

LEM Not a part of LEM.

Horizon Photometer Electronics

CM BLOCK I Additional horizon photometer and star tracker electronics mounted on an auxiliary header and attached to the right-hand wall behind the MDV.

CM BLOCK II All electronics are located in the PSA or on the sextant head.

LEM Not required.

Inertial Measurement Unit (IMU)

CM BLOCK I Size 14 IMU (14-inch case diameter) gimbal assembly including all parts inside hermetic case, entrapped coolant, and heat exchanger insulation.

CM BLOCK II AND LEM Size 12.5 IMU functionally interchangeable with Block I unit, but not physically interchangeable with Block I.

IMU Control Panel

CM BLOCK I Consists of panel, wiring, attitude error meter, CDU transfer switch, manual alignment switch, CDU mode control switches, connector, supporting hardware, and associated moisture-proofing.

CM BLOCK II Does not exist in Block II. Moding is done by AGC program and AGC push buttons.

LEM Does not exist in LEM.

Long-Eye-Relief Eyepieces

CM BLOCK I AND BLOCK II Consists of a SXT and a SCT eyepiece to provide eye relief of at least 1.6 inches for closed visor operation. Used in place of normal eyepieces of SXT and SCT.

LEM Long-eye-relief eyepiece is included as part of the AOT.

Map and Data Viewer (MDV)

CM BLOCK I AND BLOCK II Film viewer for display of maps, charts, procedures, and the like. Weight includes one film cartridge and a moisture-proofing enclosure.

LEM Not in LEM; see Book of Procedures.

NVB and Mounts

CM BLOCK I Rigid beryllium structure supporting the IMU and the optical subsystem with its associated hardware. The NVB is attached to the spacecraft using flexible resilient mounts to prevent spacecraft strains from distorting the NVB and the alignment between the IMU and optics. These mounts also provide shock and vibration attenuation.

CM BLOCK II Functionally similar to Block I but will be lighter and provide for mounting the size 12.5 IMU. The Block II NVB is attached to the spacecraft by use of strain isolation hardmounts and will have a transition piece as a result of the reorientation of the NVB so that the IMU axes will be parallel to the Command Module axes.

LEM A toroidal aluminum ring with: (1) four tubular aluminum posts to provide for IMU mounting, (2) four tubular aluminum posts for AOT mounting, and (3) three aluminum inserts to provide strain isolation ball mounting to the GAEC structure.

Optical Eyepieces

CM BLOCK I AND BLOCK II Removable SXT eyepiece and SCT eyepiece.

LEM Included as part of the AOT.

Optical Subsystem

CM BLOCK I AND BLOCK II Consists of SXT, SCT, Optical Base, and associated hardware defined as follows:

SXT:	Sextant. A two-line-of-sight, narrow-field, two-degree-of-freedom sextant and its attached gearing. The horizon photometer and automatic star tracker sensors are incorporated into the SXT head.
SCT:	Scanning Telescope. A single-line-of-sight, wide-field-of-view, two-degree-of-freedom articulation optical instrument and its attached gearing.
Optical Base:	Base for SXT and SCT with associated gearing and internal cooling.

LEM Not in LEM; see AOT.

Optical Shroud & Cover Assembly

CM BLOCK I AND BLOCK II Consists of the optical shroud and protective cover.

LEM Does not exist in LEM.

Power Servo Assembly (PSA)

CM BLOCK I Includes most of the support electronics: power supplies; IMU, Optics, and CDU servos; IMU temperature control; accelerometer and gyro pulse torquing; and horizon photometer and automatic star tracker electronics. Consists of 10 trays and replaceable modules which plug into the PSA end connector assembly. Includes a beryllium front toe plate.

CM BLOCK II Similar in function to Block I except that all horizon photometer electronics are included in the Block II PSA, and the CDU servos are deleted. Consists of a single plane matrix header, mounted to a cold plate, with the modules plugging onto the top. To permit removal of the calibration modules at IMU adjustment or replacement, these modules are contained in a separate assembly located on a cold plate adjacent to the Signal Conditioner Assembly.

LEM Consists of electronics similar to those identified in the Block II PSA minus various electronics modules. Does not include optics and photometry electronics associated with the Block I and II PSA's.

PSA End Connector Assembly

CM BLOCK I Electrical interconnection between the PSA trays, the G&N Interconnection Assy, and the G&N to S/C Interface Assy. The End Connector weight is reported in the G&N to S/C Interconnection Assembly weight.

CM BLOCK II AND LEM Not identified as a separate item; will be part of the PSA matrix header.

PSA Covers

CM BLOCK I Ten plastic connector covers, gaskets, and mounting screws (one for each tray) for moisture-proofing. Weight included in PSA weight value.

CM BLOCK II AND LEM Cover required for moisture-proofing during flight. Weight is reported in PSA weight value.

Signal Conditioner Assembly

CM BLOCK I Conditions signals for telemetry.

CM BLOCK II These modules are located in the same volume now occupied by the Block I CDU's.

LEM Same as for Block I.

~~CONFIDENTIAL~~

Appendix A

COMPARISON OF ACTUAL WEIGHTS OF DELIVERED G&N ZERO SERIES EQUIPMENT AND ESTIMATED WEIGHTS FOR G&N 100 SERIES EQUIPMENT

The following table, Table A-1, presents a comparison between the actual weights of System No. 6 equipment and the estimated weights for G&N 100 series equipment reported in section 2 of this report.

Table A-1. Weight Comparison

	System No. 6 Zero Series (lbs)	Dec '64 Weight Estimates 100 Series (lbs)
CDU	13.9	14.0 (E)
Nav/Base	94.7	92.6 (E)
IMU	61.1	60.5 (C)
PSA	58.5	59.8 (C)
G&N Interconnect*	20.5	25.0 (C)
AGC †	64.9	80.0 (E)
Optical Shroud	3.1	3.1 (C)
D&C Electronics	2.9	3.0 (E)
Control Electronics	2.1	2.1 (E)
G&N Indicator	10.1	10.5 (E)
IMU Control Panel	2.6	2.8 (E)
MDV	9.1	9.8 (C)
D&C/AGC LEB	not available	21.9 (C)
D&C/AGC MP	22.2	21.9 (C)
Optics Cover	1.6	1.6 (C)
Coolant Hoses (2)	not available	0.8 (E)

*The G&N Interconnection Assembly for the 100 series system is moisture-proofed and contains an extra cable to the Horizon Photometer Electronics located in back of the Map and Data Viewer.

†The AGC for the 100 series system includes the weight of the G&N to S/C Interface Cable Assembly, not included in the zero series system AGC.

NOTE: Basic changes in the 100 series Block I G&N system include: (1) redesigned packaging of the flight computer, (2) modification of the electronics packaging to achieve moisture-proofing and to correct deficiencies in the S&ID thermal interface material, (3) less flammable wiring insulation, and (4) addition of insulation to the cold surfaces.

DISTRIBUTION LIST

E-1142, Rev.27

Apollo Limited Internal

Alonso, R.	Halzel, I.	Mayo, G.
Apollo Library (5)	Hanley, D.	Miller, J.
Battin, R.	Hickey, E.	MIT/IL Library (W-1) (8)
Bean, W.	Hoag, D.	Nevins, J.
Bowditch, P.	Houston, F.	Nugent, J.
Boyce, A.	Hursh, J.	Olsson, E.A.
Copps, S.	Koso, A.	Schwarm, E.
Dahlen, J.	Kramer, M.	Sciagienny, J.
Dunipace, K. (AMR)	Kupfer, W.	Sears, N.
Duggan, E.	Ladd, D.	Stameris, W.
Feldman, J.B.	Larson, L.	Trageser, M.
Flanders, J.	Lawrence, J. (GAEC)	Wilk, L. (2)
Felix, S. (S&ID)	Lawton, R.	Woodbury, R.
Hall, E.C.	Marland, L.	Stone, J.

External

Delaney, Major, W. (AFSC/MIT)	(1)	Small, J. (GAEC/RASPO)	(1)
Holdridge, G.L. (NAA S&ID/MIT)	(1)	AC Spark Plug	(10)
Heuermann, T. (GAEC/MIT)	(1)	Kollsman	(10)
Rhine, W. (NASA/RASPO/MIT)	(1)	Raytheon	(10)

NAA RASPO: National Aeronautics and Space Administration (1)
 Resident Apollo Spacecraft Project Officer
 North American Aviation, Inc.
 Space and Information Systems Division
 12214 Lakewood Boulevard
 Downey, California

HDQ: NASA Headquarters (6)
 1560 H Street
 Washington, D.C.
 Attn: Mr. G.M. Low, MD (P)

GAEC: Grumman Aircraft Engineering Corporation (1)
 Bethpage, Long Island
 New York
 Attn: Mr. A. Whitaker

NAA:

North American Aviation, Inc. (1)
Space and Information System Division
12214 Lakewood Boulevard
Downey, California
Attn: Mr. R. Berry (1)

MSC:

National Aeronautics and Space Administration (41)
Manned Spacecraft Center
Houston 1, Texas
Apollo Document Control Group (SDG) (35)
Apollo Command and Service Module (3)
Attn: Mr. F. Peters
Attn: Mr. P. Ebersole (2)

WESCO

Washington Engineering Services Co., Inc. (1)
White Flint Science Park
Kensington, Maryland
Attn: Mr. J.P. Smith

WESCO (2)
68 Rogers Street
Cambridge 39, Massachusetts
Attn: Mr. J. Levy (2)

ACSP RASPO:

National Aeronautics and Space Admin. (1)
Resident Apollo Spacecraft Program Officer
Dept. 32-31
AC Spark Plug Div. of General Motors
Milwaukee, Wisconsin
Attn: Mr. W. Swingle

Mr. H. Peterson (1)
Bureau of Naval Weapons
c/o Raytheon Company
Foundry Avenue
Waltham, Massachusetts

Mr. S. Schwartz (1)
Quenns Material Quality Section
c/o Kollsman Instrument Corp.
Building A
80-08 5 Ave
Elmhurst, New York 11373

Mr. H. Anschuetz (1)
USAF Contract Mgt. District
AC Spark Plug Div. of General Motors
Milwaukee, Wisconsin 53201