

MASSACHUSETTS INSTITUTE OF TECHNOLOGY

~~CONFIDENTIAL~~

DOWNGRADED AT 3 YEAR INTERVALS:  
DECLASSIFIED AFTER 12 YEARS  
DOD DIR 5200.10

# APOLLO

## GUIDANCE AND NAVIGATION

Approved: Milton B. Trageser Date: 7/16/65  
MILTON B. TRAGESER, DIRECTOR  
APOLLO GUIDANCE AND NAVIGATION PROGRAM

Approved: Roger B. Woodbury Date: 7/21/65  
ROGER B. WOODBURY, DEPUTY DIRECTOR  
INSTRUMENTATION LABORATORY

E-1142 (Rev. 34)

(UNCLASSIFIED TITLE)

SYSTEM STATUS REPORT

July 15, 1965

Reclassified to unclassified  
by authority of J.E. [unclear]  
N.A.S.A. - SCP 7/1/70  
6-14-71  
CWS



# INSTRUMENTATION LABORATORY

CAMBRIDGE 39, MASSACHUSETTS

COPY # 18 OF 120 COPIES  
THIS DOCUMENT CONTAINS 46 PAGES

## ACKNOWLEDGEMENT

This report was prepared under DSR Project 55-238, sponsored by the Manned Spacecraft Center of the National Aeronautics and Space Administration through Contract NAS 9-4065.

This document contains information affecting the national defense of the United States within the meaning of the Espionage Laws, Title 18, U.S.C., Sections 793 and 794, the transmission or the revelation of which in any manner to an unauthorized person is prohibited by law.

The publication of this report does not constitute approval by the National Aeronautics and Space Administration of the findings or the conclusions contained therein. It is published only for the exchange and stimulation of ideas.

LIST OF EFFECTIVE PAGES

Page Numbers

Title Page through vii

1-1

2-1 through 2-8

3-1 through 3-8

4-1 through 4-5

5-1 through 5-9

A-1 through A-2

Distribution List

## CONTENTS

		Page
Section 1.	INTRODUCTION	1-1
1-1	Introduction	1-1
1-2	Accuracy	1-1
Section 2.	BLOCK I COMMAND MODULE DATA	2-1
2-1	Weights	2-1
	2-1.1 Weight Status Reporting	2-1
	2-1.2 Control Weight (100 Series)	2-1
	2-1.3 Design Load Weight (100 Series)	2-1
2-2	Reported Block I 100 Series Weight Changes	2-1
	2-2.1 PSA (-0.1 lb)	2-1
2-3	Block I (Zero Series) Weight, Center of Gravity, and Moment of Inertia Data	2-4
2-4	Command Module Power Requirements (100 Series)	2-4
2-5	Status of Command Module AGC Program	2-8
Section 3.	BLOCK II COMMAND MODULE DATA	3-1
3-1	Introduction	3-1
3-2	Reliability	3-1
3-3	Weights for the Block II Command Module	3-1
3-4	Reported Block II Weight Changes	3-1
	3-4.1 Optics Cover	3-1
3-5	Power Requirements	3-3

## CONTENTS

		Page
Section 4.	LUNAR EXCURSION MODULE DATA	4-1
4-1	Reliability	4-1
4-2	Weights for LEM	4-1
4-3	Reported LEM Weight Changes	4-1
4-4	Power Requirements	4-1
Section 5.	GLOSSARY AND SYSTEM DEFINITION	5-1
Appendix A	COMPARISON OF ACTUAL WEIGHTS OF DELIVERED G&N SERIES 50 EQUIPMENT AND ESTIMATED WEIGHTS FOR G&N 100 SERIES EQUIPMENT	A-1

## ILLUSTRATIONS

Figure		Page
2-1	Electrical Load on Primary +28 VDC Power Supply for Block I (100 Series) Systems	2-5
3-1	Electrical Load on Primary +28 VDC Power Supply	3-6
4-1	Electrical Load on Primary +28 VDC Power Supply	4-4

## TABLES

Table		Page
2-I	Current Weight Status of Block I (100 Series) Command Module	2-2
2-II	Block I (Zero Series) Weight and Balance Data	2-4
2-III	Nominal Power Dissipation (watts) vs G&N Activity for Block I (100 Series) Systems	2-6
2-IV	Block I (100 Series) Command Module Energy Consumption Profile for 8.27-Day Lunar Orbit Mission	2-7
2-V	Current Memory Capacity of Command Module AGC Programs (7/15/65)	2-8
3-I	Reliability Estimates for Variations of AMPTF Design Reference Mission	3-2
3-II	Current Weight Status of Block II Command Module	3-4
3-III	Nominal Power Dissipation (watts) vs G&N Activity for Block II Systems	3-7
3-IV	Block II Command Module Energy Consumption Profile for 8.27-Day Lunar Orbit Mission	3-8
4-I	Reliability Estimate for LEM G&N Based on AMPTF Design Reference Mission	4-2
4-II	Estimated Weights of LEM G&N Command Module	4-3
4-III	Lunar Excursion Module Power Profile Based on GAEC Report LED-540-12	4-5

## ABSTRACT

The System Status Report is distributed monthly on the 15th. This month's revision of E-1142 (Rev. 34) contains, in general, the following for the Block I and Block II Command Module and Lunar Excursion Module equipment: configuration weights, centers of gravity, moments of inertia, power requirements, status of computer programs, and reliability values.

## Section 1

### INTRODUCTION

#### 1-1 INTRODUCTION

The following information is included in this month's report:

- (1) Command Module, Block I  
100 Series: Weights and power requirements  
Zero Series: Centers of gravity and moments of inertia  
Guidance and Navigation Lunar Land Mission: Status of computer and reliability values.
- (2) Command Module, Block II  
Integrated Guidance, Navigation, and Control Configuration: Weights and reliability values.
- (3) Lunar Excursion Module  
LEM integrated Guidance and Control Configuration: Weights and reliability values.

The definition of what constitutes Block I, Block II, and LEM hardware is contained in the Glossary, section 5. Also included is Appendix A which shows the actual component weights of delivered Guidance Navigation & Control System No. 17 and the latest weight estimates for the G&N 100 series equipment.

#### 1-2 ACCURACY

The accuracy of numerical values reported in this revision should not be considered to be within the tolerances implied by the significant figures quoted. The reported values, although based upon the most current information, are subject to normal changes as design and development phases approach completion.



# BLOCK I COMMAND MODULE

## Section 2

### BLOCK I COMMAND MODULE DATA

#### 2-1 WEIGHTS

Table 2-I presents the weights of all Block I flight (100 series) systems equipment, grouped according to specific location within the Command Module. Weights are reported to the component level and to the nearest tenth of a pound.

Given component weights are identified as estimated, calculated, and measured in order of increasing accuracy. These terms are defined by North American Aviation as follows: estimated weights (E) are based on rough calculations; calculated weights (C) are based on detailed calculations made from final production drawings that will be used to build flyable equipment; measured weights (M) are actual weights of equipment built to the production drawings.

North American Aviation will provide and be responsible for cold plate weights that are not integral with guidance and control equipment.

2-1.1 WEIGHT STATUS REPORTING. Table 2-I also offers a comparison of present 100 series component weight values with those listed in System Status Report, E-1142 (Rev. 33), June 15, 1965. All weight changes are explained in paragraph 2-2.

2-1.2 CONTROL WEIGHT (100 SERIES). Column (a) in Table 2-I contains the total control weight for the Apollo G&N 100 series equipment as specified in letter EG-151-44-65-55 (February 10, 1965) from Mr. R.W. Young, ASPO, to Mr. M. Trageser, MIT/IL.

2-1.3 DESIGN LOAD WEIGHT (100 SERIES). Column (d) of Table 2-I contains the "not to exceed" design load weights for individual Block I G&N 100 series subsystems. These weights were assigned per ICD MH01-01256-416, signed June 3, 1965.

#### 2-2 REPORTED BLOCK I 100 SERIES WEIGHT CHANGES

2-2.1 PSA (-0.1 lb). The weight decrease is based on the weighing of the PSA for system 110 and calculated values of the Signal Conditioner Power Supply and Photometer Electronics Modules.

**CONFIDENTIAL**  
**BLOCK I**  
**COMMAND MODULE**

Table 2-1. Current Weight Status of Block I (100 Series) Command Module (lbs at 1 g)

Item	100 Series Control Weight (a)	(b-a)	100 Series Status 6/65 (b)	(c-d)	100 Series Status 7/65 (c)	100 Series Design Load Wt. 1/65 (d)
<u>G&amp;N SYSTEMS</u>						
CDU Assy			14.1 (M)	0.0	14.1 (M)	16.0
Optical Subsystem						
SXT			18.7 (E)	0.0	18.7 (E)	155.0*
SCT			14.3 (E)	0.0	14.3 (E)	
Optical Base & Gearing			17.0 (E)	0.0	17.0 (E)	
NVB & Resilient Mounts			25.7 (M)	0.0	25.7 (M)	
Bellows Assy			12.7 (M)	0.0	12.7 (M)	
IMU			60.5 (C)	0.0	60.5 (C)	
Coolant Hoses (two)			0.8 (E)	0.0	0.8 (E)	
Power Servo Assy			59.8 (C)	-0.1	59.7 (M)	120.0
G&N Interconnection Assy			27.3 (E)	0.0	27.3 (E)	
G&N tp S/C Interface Assy } AGC (no spares)			87.0 (M)	0.0	87.0 (M)	100.0
Optical Shroud			3.1 (E)	0.0	3.1 (E)	4.5
<u>LOWER EQUIPMENT BAY</u>						
<u>D&amp;C</u>						
D&C Electronics			3.0 (E)	0.0	3.0 (E)	5.0
Control Electronics			2.1 (E)	0.0	2.1 (E)	4.0
G&N Ind. Control Panel			10.5 (E)	0.0	10.5 (E)	15.0
IMU Control Panel			2.8 (E)	0.0	2.8 (E)	5.0
Condition Annunciator Assy			1.2 (E)	0.0	1.2 (E)	2.0
D&C/AGC			23.0 (M)	0.0	23.0 (M)	26.0
Horizon Photometer Electronics			2.2 (C)	0.0	2.2 (C)	4.0
Signal Conditioner Assy			3.9 (C)	0.0	3.9 (C)	8.0
<u>MAIN PANEL AREA</u>						
D&C/AGC			25.2 (E)	0.0	25.2 (E)	26.0

CONFIDENTIAL  
BLOCK I  
COMMAND MODULE

Table 2-I. Current Weight Status of Block I (100 Series) Command Module (lbs at 1 g) (cont)

Item	100 Series Control Weight (a)	(b-a)	100 Series Status 6/65 (b)	(c-b)	100 Series Status 7/65 (c)	100 Series Design Load Wt. 1/65 (d)
<u>LOOSE STORED ITEMS</u>						
Optical Eyepieces						
SXT			1.6 (C)	0.0	1.6 (C)	
SCT			2.6 (C)	0.0	1.6 (C)	7.2
Eye Relief Eyepieces			1.5 (E)	0.0	1.5 (E)	
Optics Cover			1.6 (C)	0.0	1.6 (C)	2.5
Horizontal Hand Holds			1.0 (E)	0.0	1.0 (E)	1.0
Lens Cleaning Kit			0.1 (E)	0.0	0.1 (E)	
Total	430.0†	-6.7	423.3	-0.1	423.2	522.0§

\* This Design Load weight is figured to include only 1/2 the weight of the Bellows Assembly.

† Total Control Weight specified in letter EG-151-44-55 (February 10, 1965), from Mr. R. W. Young, ASPO, to Mr. M. Trageser, MIT/IL. See paragraph 2-1.2.

§ Design Load Weights are taken from ICD MH01-01256 (signed June 3, 1965, submitted by MIT by letter AG-478-65).

**CONFIDENTIAL**  
**BLOCK I**  
**COMMAND MODULE**

**2-3 BLOCK I (ZERO SERIES) WEIGHT, CENTER OF GRAVITY, AND MOMENT OF INERTIA DATA**

At the present time since Block I (100 series) G&N equipment is not available in-house and ACSP is not contractually obligated to perform moments of inertia calculations or measurements. MIT is using Block I zero series information and final production drawings to calculate the Block I (100 series) moments of inertia and centers of gravity. These data will appear in future reports. Table 2-II summarizes Block I (zero series) data.

Table 2-II. Block I (Zero Series) Weight and Balance Data

Weight (lb)	Center of Gravity (in)	Moments of Inertia* (slug ft <sup>2</sup> )
408.9	X 55.1 Y -0.3 Z 37.3	Ixx 146.8 Iyy 413.1 Izz 282.1

\*Values determined with respect to the basic X, Y, Z axes of the Command Module.

**2-4 COMMAND MODULE POWER REQUIREMENTS (100 SERIES)**

The power requirements of the Command Module G&N 100 series equipment on the primary +28 VDC power supply are shown in figure 2-1 which presents the magnitude and location of dissipated power values on a subassembly level. This assumes an 8.27-day mission, as defined by the Apollo Mission Planning Task Force (AMPTF) for power profile computation, and is based on a 28 VDC input at the connectors. The values shown are average values. (Ref: GAEC Report No. LED-540-12, October 30, 1964.)

Table 2-III shows the magnitude and location of power dissipation for the established G&N activities, each of which consists of various power levels of operation.

Table 2-IV shows the energy requirements for each G&N activity on a power level basis. The table is based upon MIT letter AG-679-6, "G&N Power Profile Status," dated August 14, 1963. The vertical column to the left indicates the various G&N activities (phases of operation) for the model 8.27-day mission submitted by the AMPTF (GAEC Report No. LED-540-12, October 30, 1964). The column also indicates the power requirement and operating time for each specific activity. The top row indicates the power requirement and operating time for each G&N power consuming equipment. The table sums up the energy consumption for each G&N activity and each G&N power consuming equipment.

# BLOCK I COMMAND MODULE

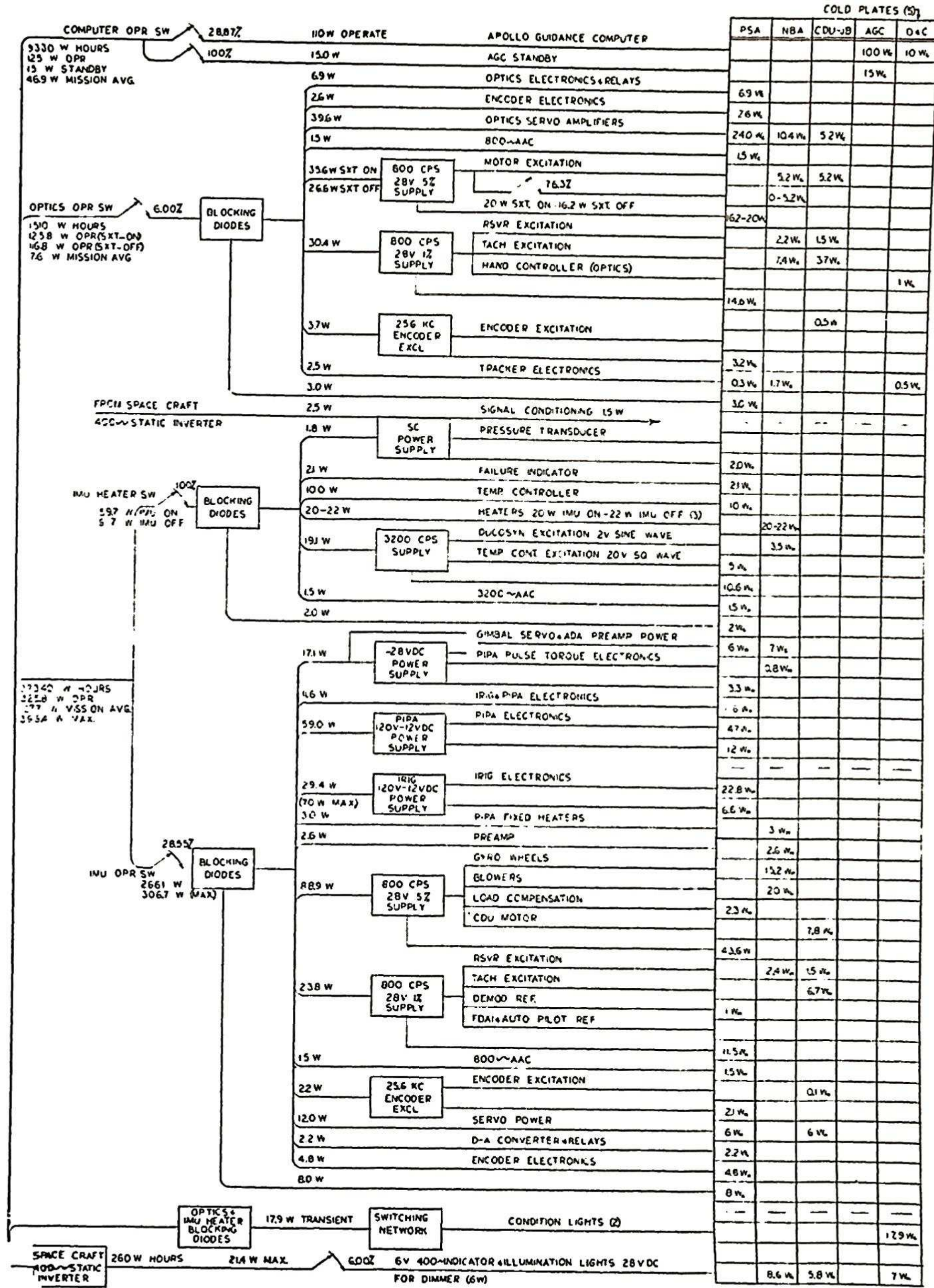

**28 PRIMARY** GUIDANCE + NAVIGATION LOAD ON PRIMARY + 28VDC  
 CODE: (1) CALCULATED (2) ESTIMATED (3) MEASURED  
**TOTALS:** 38440 W HOURS  
 1933 W MISSION AVG  
 6386 W WORST POSSIBLE  
 5980 W ALL SYSTEMS OPERATING

**NOTES:**  
 (1) TO S+C  
 (2) INTERMITTENT OPERATION (LESS THAN 1% ON-TIME)  
 (3) 22W, "ZERO" G ENVIRONMENT  
 33W, "ONE" G ENVIRONMENT  
 (4) TO SIGNAL CONDITIONING ASSEMBLY  
 (5) REQUIRES NO THERMAL LOAD ON SPACECRAFT COOLANT

Figure 2-1. Electrical Load on Primary +28 VDC Power Supply for Block I (100 Series) Systems

BLOCK I  
COMMAND MODULE

Table 2-III. Nominal Power Dissipation (watts) vs G&N Activity for Block I (100 Series) Systems

M O D E	G&N Activity (power levels)	NBA		CDU JB		PSA		AGC	Thermal Load on S/C Coolant	D&C and S&C	Optics External	Electrical Load
		IMU	D&C and OBA	IMU	D&C and OBA	IMU	OBA					
A	Accomplish & Confirm Course Corrections Inactivity & Monitor Major Maneuvers (1, 5)	74.5	0.0	22.1	0.0	228.5	0.0	115.0	440.1	10.7	0.0	450.8
B	IMU Alignments Sextant Sightings (Midcourse Navigation) (1, 3, 5, 7)	74.5	40.7	22.1	21.9	228.5	76.1	115.0	578.8	18.7	0.5	598.0
C	Landmark Trackings (Low-orbit Navigation) (1, 4, 5, 7)	74.5	35.5	22.1	21.9	228.5	72.3	115.0	569.8	18.7	0.5	589.0
D	Inactivity & Monitor (1, 6)	25.5	0.0	0.0	0.0	36.2	0.0	115.0	176.7	10.0	0.0	186.7
E	Sextant Sightings (Midcourse Navigation) (1, 3, 6, 7)	25.5	40.7	0.0	21.9	36.2	76.1	115.0	315.4	18.0	0.5	333.9
F	Inactivity & Monitor	25.5	0.0	0.0	0.0	36.2	0.0	15.0	76.7	0.0	0.0	76.7

1. AGC Operate 125.0 watts
2. AGC Standby 15.0 watts
3. Optics Operate SXT On 125.8 watts
4. Optics Operate SXT Off 116.8 watts
5. IMU Operate 325.8 watts
6. IMU Standby 61.7 watts
7. D&C Operate 21.4 watts

BLOCK I

COMMAND MODULE

Table 2-IV. Block I (100 Series) Command Module Energy Consumption Profile for 8.27-Day Lunar Orbit Mission

M O D E	G&N Activity	Energy Consumption (kwh)							Total
		(1) AGC Operate 125.0 watts 57.38 hours	(2) AGC Standby 15.0 watts 141.31 hours	(3) Optics Sextant ON 125.8 watts 9.08 hours	(4) Optics Sextant OFF 116.8 watts 2.83 hours	(5) IMU Operate 325.8 watts 56.73 hours	(6) IMU Standby 61.7 watts 141.96 hours	(7) D&C Operate 21.4 watts 11.91 hours	
A	Accomplish & Confirm Course Correction Major Maneuvers Inactivity & Monitor 450.8 watts 45.12 hours	5.640	—	—	—	14.700	—	—	20.340
B	IMU Alignments Sextant Sightings (Midcourse Navigation) 598.0 watts 9.08 hours	1.135	—	1.142	—	2.958	—	0.194	5.429
C	Landmark Tracking (Low-Orbit Navigation) 589.0 watts 2.83 hours	0.354	—	—	0.330	0.922	—	0.060	1.666
D	Inactivity & Monitor 186.7 watts 0.35 hours	0.044	—	—	—	—	0.022	—	0.066
E	Sextant Sightings (Midcourse Navigation) 333.9 watts 0.30 hours	0.038	—	0.038	—	—	0.019	0.006	0.101
F	Inactivity & Monitor 76.7 watts 141.31 hours	—	2.119	—	—	—	8.719	—	10.838
	Total 198.55 hours	7.211	2.119	1.181	0.330	18.580	8.760	0.260	38.440

BLOCK I  
COMMAND MODULE

2-5 STATUS OF COMMAND MODULE AGC PROGRAM

The Block I Command Module program status (Table 2-V) reflects the lunar landing mission exclusive of the stabilization and control function.

The Block II Command Module computer program, which contains S&C functions, is in the process of being calculated and will be reported when the values become established.

Table 2-V. Current Memory Capacity of Command Module  
AGC Programs (7/15/65)

Item	Memory Words
List Processing Interpreter	1762
AGC Executive	318
AGC Waitlister	190
AGC Self-Check	889
G&N System Test	1699
Display & Keyboard	2847
Input/Output Control	1769
Navigation	1775
Powered Flight Guidance & Attitude Control	1052
Prelaunch Alignment	782
In-Flight Alignment*	925
Re-Entry	1543
Re-Start and First Start	468
Mission Sequencing (202)	960
Miscellaneous	497
	17476

\*Estimated.



# BLOCK II COMMAND MODULE

## Section 3

### BLOCK II COMMAND MODULE DATA

#### 3-1 INTRODUCTION

Preliminary ICD MH01-01304-116 has relieved MIT of the design responsibility for the optics cover and assigned the design effort to NAA. For this reason a weight reduction is shown in the report. The optics cover is to be used also as a work-table during the flight mission.

During the reporting period, a mechanical interface meeting (129B) was held at NAA with MIT in attendance. One of the items on the agenda was the possibility of assigning NAA design responsibility for the Block II coolant hoses.

When MIT receives official direction to remove the coolant hoses as MIT supplied hardware, a corresponding weight reduction will be shown.

#### 3-2 RELIABILITY

The operating times and associated mission success probabilities in Table 3-I are based upon the Apollo Mission Planning Task Force (AMPTF) time line listed in GAEC Report LED-540-12, dated October 30, 1964, which uses the interval of Command Module operation from earth launch until LEM separation.

#### 3-3 WEIGHTS FOR THE BLOCK II COMMAND MODULE

Table 3-II shows the weights of the Block II Command Module Integrated Guidance and Control System.

#### 3-4 REPORTED BLOCK II WEIGHT CHANGES

3-4.1 OPTICS COVER (-1.6 lbs). NAA has design responsibility for the optics cover. (For further explanation see paragraph 3-1.)

**CONFIDENTIAL**  
**BLOCK II**  
**COMMAND MODULE**

**Table 3-I. Reliability Estimates For Variations of AMPTF Design Reference Mission**  
 (Probability of success of CSM PGNCS from earth launch until LEM separation.  
 Elapsed time of approximately 68 hours.)

PGNCS Subsystem	Operate Failure Rate Per 10 <sup>6</sup> hrs	Operate Time (hrs)	Standby Failure Rate Per 10 <sup>6</sup> hrs	Standby Time (hrs)	Failures Per 10 <sup>6</sup> Missions	Success Probability
IMU	129	12.5	7.8	55.6	2046	0.99796
IMU Electronics	110	12.5	6.3	55.6	1725	0.99827
CDU (IMU)	171	12.5	0	55.6	2138	0.99797
Optics	94	7.8	0	59.1	733	0.9993
Optics Electronics	77	7.8	0	59.1	601	0.9994
CDU (Optics)	114	7.8	0	59.1	889	0.9992
AGC	357	12.5	96.4	55.6	9822	0.991
DSKY (2)	117/125 hrs	12.5	0	55.6	117	0.99999*
D&C	13	12.5	0	55.6	163	0.99994
Total					18234	0.982

\*Success requires that only one of redundant pair of DSKY's not fail.

## BLOCK II COMMAND MODULE

### 3-5 POWER REQUIREMENTS

The power requirements of the Block II Command Module G&N equipment on the primary +28 VDC power supply are shown in figure 3-1, which presents the magnitude and location of dissipated power values on a subassembly level. This chart assumes an 8.27-day lunar orbit mission as defined by the Apollo Mission Planning Task Force (AMPTF) for power profile computation and is based on a 28 VDC input at the connectors. These values are average values (Ref: GAEC Report LED-540-12, October 30, 1964).

Table 3-III shows the magnitude and location of power dissipation for the established G&N activities, each of which consists of various power levels of operation.

Table 3-IV shows the energy requirements for each G&N activity on a power level basis. The table is based on MIT letter AG 679-6, "G&N Power Profile Status," dated August 14, 1963. The vertical column to the left indicates the various G&N activities (phases of operation) for the model 8.27-day lunar mission submitted by AMPTF (GAEC Report LED-540-12, October 30, 1964). This column also indicates the power requirements and operating time for each specific activity. The top row indicates the power requirements and operating time of each G&N activity and each G&N power consuming equipment. The total power consumption for each G&N activity and each G&N power consuming equipment is also given.

**CONFIDENTIAL**  
BLOCK II  
**COMMAND MODULE**

Table 3-II. Current Weight Status of Block II Command Module (lbs at 1 g)

Item	Control Weight (a)	Status 6/65 (b)	(c-b)	Status 7/65 (c)	Design Load Wt. 5/64 (d)
<u>G&amp;N SYSTEMS</u>					
CDU Assy		33.0 (E)	0.0	33.0 (E)	
Optical Subsystem		18.7 (E)	0.0	18.7 (E)	
SXT		14.3 (E)	0.0	14.3 (E)	
SCT		17.0 (E)	0.0	17.0 (E)	
Optical Base & Gearing					
Optical Eyepieces *					
SXT		4.4 (E)	0.0	4.4 (E)	
SCT		4.7 (E)	0.0	4.7 (E)	
NVB & Mounts		14.9 (E)	0.0	14.9 (E)	
Bellows Assy		12.7 (E)	0.0	12.7 (E)	
IMU		41.3 (E)	0.0	41.3 (E)	
Coolant Hoses (two)		0.8 (E)	0.0	0.8 (E)	
Power Servo Assy†		41.5 (E)	0.0	41.5 (E)	
PIPA Electronics Assy		7.9 (E)	0.0	7.9 (E)	
Interconnect Harness Assy		30.0 (E)	0.0	30.0 (E)	
AGC		58.0 (E)	0.0	58.0 (E)	
Optical Shroud		3.1 (E)	0.0	3.1 (E)	
<u>LOWER EQUIPMENT BAY</u>					
<u>D&amp;C</u>					
G&N Indicator Control Panel		12.1 (E)	0.0	12.1 (E)	
D&C/AGC		17.5 (E)	0.0	17.5 (E)	
Signal Conditioner Assy		6.5 (E)	0.0	6.5 (E)	
<u>MAIN PANEL AREA</u>					
D&C/AGC		17.5 (E)	0.0	17.5 (E)	

**CONFIDENTIAL**  
BLOCK II  
**COMMAND MODULE**

Table 3-II. Current Weight Status of Block II Command Module (lbs at 1 g) (cont)

Item	Control Weight <sup>~</sup> (a)	(b-a)	Status 6/65 (b)	(c-b)	Status 7/65 (c)	Design Load Wt. 5/64 (d)
<u>LOOSE STORED ITEMS</u>						
Optics Cover			1.6 (E)	-1.6	0.0	
Horizontal Hand Holds			1.0 (E)	0.0	1.0 (E)	
Lens Cleaning Kit			0.1 (E)	0.0	0.1 (E)	
Total	400.0§	-41.4	358.6	-1.6	357.0	492.6**

\* The eyepiece weights quoted here are for the full-magnification 2.2-inch eye-relief eyepieces designed by MIT under NASA direction. At this time MIT is awaiting NASA instructions as to which of the two possible eyepiece designs to use in the Block II G&N.

† Includes the weight of the PSA Cover.

§ Total Control Weight specified in letter EG-151-44 (February 10, 1965) from Mr. R. W. Young, ASPO, to Mr. M. Trageser, MIT/IL. See paragraph 2-1.2.

\*\*Design Load Weight taken from S&ID letter 64 MA 2-32 (February 11, 1964). It does not include loose stored items.



BLOCK II

COMMAND MODULE

Table 3-III. Nominal Power Dissipation (watts) vs G&N Activity for Block II Systems

MODE	G&N Activity (power levels)	NBA		CDU		PSA		AGC	Thermal Load on S/C Coolant	D&C and S&C	Electrical Load
		IMU	OBA	IMU	OBA	IMU	OBA				
A	Accomplish & Confirm Course Corrections Inactivity & Monitor Major Maneuvers (1, 4)	78.6	0.0	32.8	0.0	154.3	0.0	100.0	365.7	10.7	376.7
B	IMU Alignments Sextant Sightings (Midcourse Navigation) Landmark Tracking (Low-orbit Navigation) (1, 3, 4, 6)	78.6	32.8	44.9	18.7	154.3	62.7	100.0	491.5	33.8	525.3
C	Inactivity & Monitor (1, 5)	28.0	0.0	0.0	0.0	18.0	0.0	100.0	146.0	10.0	156.0
D	Sextant Sightings (Midcourse Navigation) (1, 3, 5, 6)	28.0	43.7	0.0	18.7	18.0	62.7	100.0	271.5	33.1	304.6
E	Inactivity & Monitor (2, 5)	28.0	0.0	0.0	0.0	18.0	0.0	10.0	56.0	0.0	56.0

1. AGC Operate 110.0 watts
2. AGC Standby 10.0 watts
3. Optics Operate 126.5 watts
4. IMU Operate 266.7 watts
5. IMU Standby 46.0 watts
6. D&C Operate 22.1 watts

BLOCK II  
COMMAND MODULE

Table 3-IV. Block II Command Module Energy Consumption Profile for 8.27-Day Lunar Orbit Mission

M O D E	G&N Activity	Energy Consumption (kwh)						Total
		(1) AGC Operate 110.0 watts 57.38 hours	(2) AGC Standby 10.0 watts 141.31 hours	(3) Optics Operate 126.5 watts 11.91 hours	(4) IMU Operate 266.7 watts 56.73 hours	(5) IMU Standby 46.0 watts 141.96 hours	(6) D&C Operate 22.1 watts 11.91 hours	
<b>A</b>	Accomplish & Confirm Course Corrections Major Maneuvers Inactivity & Monitor 376.7 watts 45.12 hours	4.963	—	—	12.034	—	—	16.997
<b>B</b>	IMU Alignments Sextants Sightings (Midcourse Navigation) Landmark Trackings (Low-orbit Navigation) 525.3 watts 11.61 hours	1.277	—	1.469	3.096	—	0.257	6.099
<b>C</b>	Inactivity & Monitor 156.0 watts 0.35 hours	0.039	—	—	—	0.016	—	0.055
<b>D</b>	Sextant Sightings (Midcourse Navigation) 304.6 watts 0.30 hours	0.033	—	0.038	—	0.014	0.007	0.092
<b>E</b>	Inactivity & Monitor 56.0 watts 141.31 hours	—	1.413	—	—	6.500	—	7.913
	<b>Total</b> 198.55 hours	6.312	1.413	1.507	15.130	6.530	0.264	31.156



# LUNAR EXCURSION MODULE

## Section 4

### LUNAR EXCURSION MODULE DATA

#### 4-1 RELIABILITY

The operating times and associated mission success probabilities in Table 4-I are based upon the Apollo Mission Planning Task Force (AMPTF) time line listed in GAEC Report No. LED-540-12, dated 30 October 1964, which uses the interval of LEM operation from earth launch to lunar touchdown.

#### 4-2 WEIGHTS FOR LEM

Lunar Excursion Module weights are presented in Table 4-II. In general the data conform to the information contained in paragraphs 2-1, 2-1.1, and 2-1.2.

The row labeled "Bare Guidance System" is inserted to provide for comparisons with similarly specified systems.

#### 4-3 REPORTED LEM WEIGHT CHANGES

No weight changes have been reported this month.

#### 4-4 POWER REQUIREMENTS

The estimate for LEM power and energy consumption shown in figure 4-1 is based upon the 8.27-day lunar orbit mission as defined by the Apollo Mission Planning Task Force (AMPTF) for power profile computation (Ref: GAEC Report LED-540-12, dated October 30, 1964).

Table 4-III shows the energy requirements for each G&N activity on a power level basis. The table is also based upon GAEC Report LED-540-12. The vertical column on the left indicates the various G&N activities (phases of operation). This column also indicates the power requirements and operating time for each activity. The top row indicates the power requirements and operating time of each G&N power consuming equipment. The table sums up the energy consumption for power consuming equipment.

CONFIDENTIAL

LUNAR EXCURSION MODULE

Table 4-1. Reliability Estimate for LEM G&N Based on AMPTF Design Reference Mission  
(Probabilities for LEM PGNCs from earth launch until LEM touchdown.)

PGNCs Subsystem	Operate Failure Rate Per 10 <sup>6</sup> hrs	Operate Time (hrs)	Standby Failure Rate Per 10 <sup>6</sup> hrs	Standby Time (hrs)	Failures Per 10 <sup>6</sup> Missions	Success Probability
IMU	129	3.25	7.8	66.2	936	0.9991
IMU Electronics	105	3.25	6.3	66.2	758	0.9993
CDU (IMU)	183	3.25	0	0	595	0.9995
Optics	38	3.25	0	0	124	0.99988
Optics Electronics	38	3.25	0	0	124	0.99988
CDU (Optics)	122	3.25	0	0	397	0.9997
AGC	357	3.25	0	0	1160	0.9989
DSKY	293	3.25	0	0	952	0.9991
D&C	13	3.25	0	0	42	0.99996
Total					5088	0.9995

**CONFIDENTIAL**  
**LUNAR EXCURSION MODULE**

Table 4-II. Estimated Weights of LEM G&N Command Module (lbs at 1 g)

Item	Control Weight (a)	(a-b)	Status 6/65 (b)	(c-b)	Status 7/65 (c)	Design Load Wt. 7/64 (d)
CDU's			33.0 (E)	0.0	33.0 (E)	*
Telescope and all Eyepieces			25.5 (E)	0.0	25.5 (E)	
IMU			41.3 (E)	0.0	41.3 (E)	
LGC/PSA Interconnection Assy			10.0 (E)	0.0	10.0 (E)	
LGC Display and Controls			17.5 (E)	0.0	17.5 (E)	
Book of Procedures, etc.			2.0 (E)	0.0	2.0 (E)	
LGC			58.0 (E)	0.0	58.0 (E)	
NVB			6.0 (E)	0.0	6.0 (E)	
PSA			15.2 (E)	0.0	15.2 (E)	
Pulse Torque Assy (PTA)			12.0 (E)	0.0	12.0 (E)	
Signal Conditioner Assy			6.2 (E)	0.0	6.2 (E)	
Total	240.0†	-13.3	226.7	0.0	226.7	
Bare Guidance System (IMU, PSA, PTA, and LGC)			126.5	0.0	126.5	

\* No design load weight has been assigned.

† Total Control Weight specified in Letter EG-151-44-65 (February 10, 1965) from Mr. R. W. Young, ASPO, to Mr. M. Trageser, MIT/IL. See Section 2-1.2.

# LUNAR EXCURSION MODULE

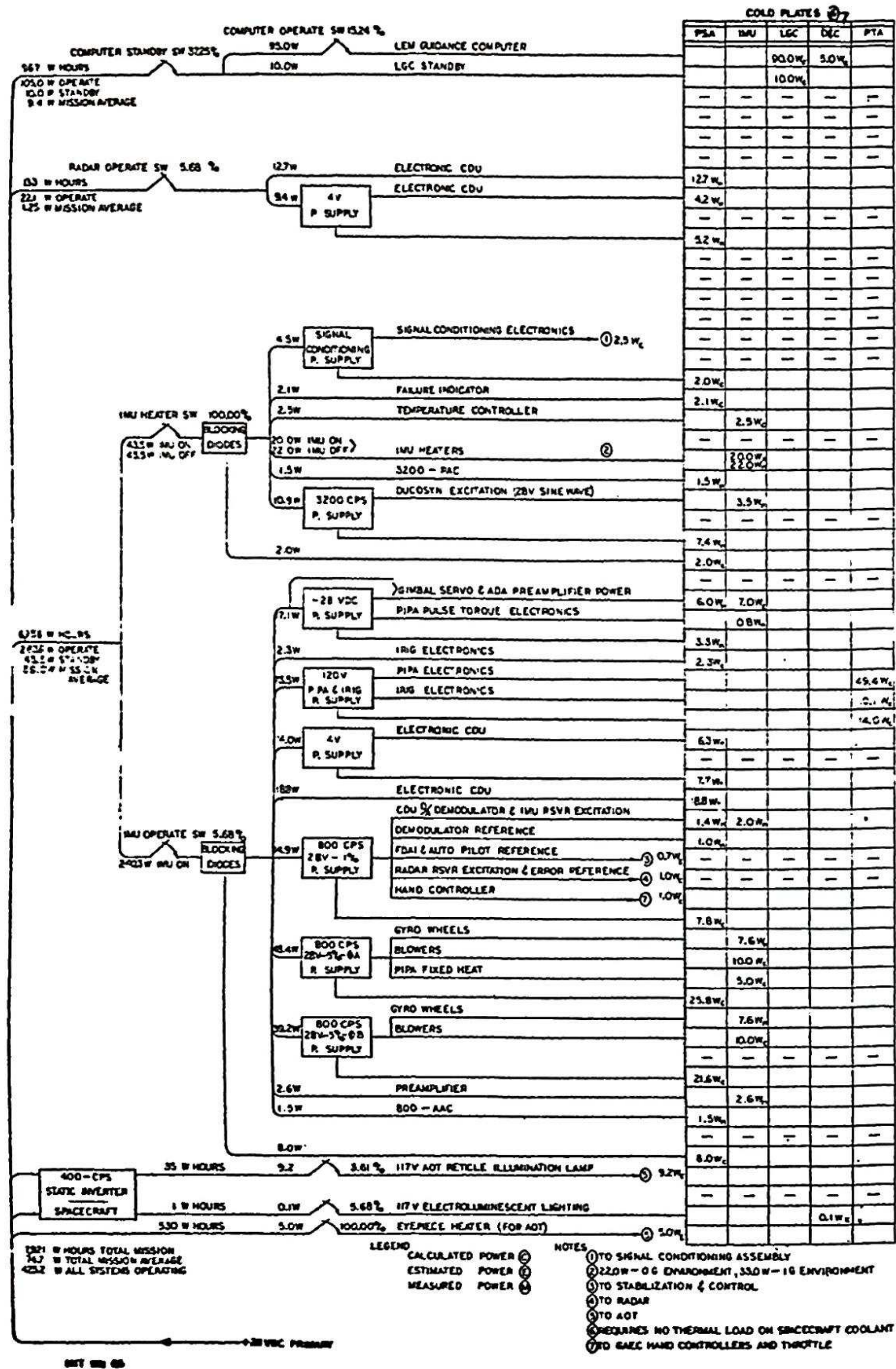

Figure 4-1. Electrical Load on Primary +28 VDC Power Supply

# LUNAR EXCURSION MODULE

Table 4-III. Lunar Excursion Module Power Profile Based on GAEC Report LED-540-12

M O D E	Activity	Energy Consumption (kwh)								Total
		(1) LGC Off 0 watts 66.52 hours	(2) LGC Operate 105 watts 6.02 hours	(3) LGC Standby 10 watts 33.48 hours	(4) DMU Operate 283.8 watts 6.02 hours	(5) DMU Standby 45.5 watts 100 hours	(6) Two Radar CDU Operate 22.1 watts 6.02 hours	(7) OMU (AOT) Operate 9.2 watts 3.83 hours	(8) AOT Eyepiece heater 5 watts 106.02 hours	
I	Inactivity 50.5 watts 66.52 hours	0.000	-	-	-	3.027	-	-	0.333	3.360
II	Inactivity Alignment Midcourse Measurements 429.1 watts 3.83 hours	-	0.402	-	1.084	-	0.085	0.035	0.019	1.625
III	Guidance During Major Event 415.9 watts 2.19 hours	-	0.230	-	0.622	-	0.048	-	0.011	0.911
IV	Inactivity 60.5 watts 33.48 hours	-	-	0.335	-	1.523	-	-	0.167	2.025
	Total 106.02 hours	0.000	0.632	0.335	1.706	4.550	0.133	0.035	0.530	7.921

## Section 5

### GLOSSARY AND SYSTEM DEFINITION

#### Apollo Guidance Computer (AGC)

CM BLOCK I A single complete flight computer containing all logic, memory associated power supplies, and all interface circuits except those identified with the CDU's. Does not contain the associated displays and controls.

Consists of one case containing factory replaceable electronic modules. Includes cover for moisture-proofing, but does not include the necessary cold plate or the G&N to S/C Interface Assembly which is located in the adjacent area.

CM BLOCK II AND LEM Many modules have been redesigned and repackaged in a separate case. The CDU's are either adjacent to or on the opposite side of the same cold plate as the AGC. Memory capacity is increased over Block I.

#### Alignment Optical Telescope (AOT)

CM BLOCK I AND CM BLOCK II Not in CM; see Optical Subsystem.

LEM A three-position periscope with single-degree-of-freedom, manually read reticule for alignment of the IMU. Includes the weight of the bellows assembly, a long-eye-relief eyepiece, and regular eyepiece.

#### Bellows Assembly

CM BLOCK I Consists of two flexible metal bellows forming pressure seal between CM & optical subsystem for penetration of hull for optics.

CM BLOCK II Same except for two elastomeric seals and transition pieces.

LEM One bellows with a double convoluted wall and two seals providing a flexible seal for pressure penetration of the AOT in the spacecraft. This weight is included in the AOT value.

### Condition Annunciator Assembly

CM BLOCK I Visually displays G&N system malfunctions. This function was previously part of the Map & Data Viewer.

CM BLOCK II AND LEM Not defined as yet for Block II and LEM.

### Coupling Data Unit (CDU) Assembly

The CDU provides the necessary signal interface among the IMU gimbal angles, optics gimbal angles, radar gimbal angles, angle registers in the AGC, the spacecraft autopilot attitude error signals, and the tracking radar command error signals.

CM BLOCK I Five interchangeable gear boxes each with necessary motor tachometer, resolver synchros, and encoder with mounting frame work. Does not include associated electronics which are located in the PSA.

CM BLOCK II Functionally identical to Block I except the instrumentation is all electronic. Includes all support electronics (including special power supply) and header mounted adjacent to the AGC. Changes in resolver synchro characteristics and mode controls make Block I and II CDU's noninterchangeable.

LEM Interchangeable with CM Block II CDU's except for the headers.

### Cold Plates

CM BLOCK I, BLOCK II, AND LEM Cold plates for the IMU are built into the IMU. Necessary cold plates for electronics are part of the equipment supplied by the spacecraft manufacturer. All surfaces over glycol coolant passages and open to the cabin environment will be insulated to prevent moisture condensation.

### Control Electronics Assembly

CM BLOCK I Consists of one power transformer, one relay and diode module, and a bracket end connector mounted behind G&N indicator control panel to support display and control functions. Includes moisture-proofing.

CM BLOCK II Not required in Block II. These functions are now incorporated into the PSA.

LEM Not required in LEM.

### Coolant Hoses

CM BLOCK I AND CM BLOCK II Consists of (1) two steel flex coolant hoses, one between IMU and spacecraft and one between optics and spacecraft, (2) bracket assembly screws and clamp, and (3) entrapped coolant.

LEM Not identified as part of LEM.

### Display and Control/Apollo Guidance Computer (D&C/AGC)

CM BLOCK I Number displays and keyboard control associated with the operation of the AGC. Two functionally identical and parallel operating units in each CM system, one in lower equipment bay and one on main panel between left and center couches.

CM BLOCK II Mechanically and electrically identical to Block I but smaller configuration because of smaller relays. The Block II display and keyboard controls will be hermetically sealed by encasing the unit in a container.

LEM Identical to Block II except only a single unit is required.

### D&C Electronics Assembly

CM BLOCK I Consists of a chassis, a relay and diode module, a demod. elect. module, a saturable reactor, a time delay module, a connector, and wiring and is mounted behind the G&N Indicator Control Panel. Used to support display and control functions. Connectors will be moisture-proofed.

CM BLOCK II Not required in Block II. These functions now incorporated in the PSA.

LEM Not defined in LEM at this time.

### Flight Data Book/Book of Procedures

CM BLOCK I, CM BLOCK II, AND LEM Book or other form of maps, charts, procedures, instructions and the like, needed for use during the Apollo Mission.



### G&N Indicator Control Panel

CM BLOCK I Consists primarily of controls and displays for the operation of the optics, IMU temperature control, panel brightness control, and attitude impulse control. It includes display and control elements, panel, panel wiring, supporting hardware, and moisture-proofing.

CM BLOCK II Functionally the same as Block I; however, redesigned as follows: Panel thickness decreased, integrated lighting and function lights added, wiring changed, and the hand controller attitude impulse switch changed.

LEM Does not exist in LEM.

### G&N Interconnection Assembly

CM BLOCK I Consists of PSA End Connector Assembly and interconnect wiring harness, which electrically ties together the assemblies that constitute a completely integrated system. This term does not include weights of harness support brackets, which are an NAA responsibility, or the G&N to S/C Interface Assembly weight.

CM BLOCK II Not in Block II.

LEM Not clearly defined but at present is called the LGC/PSA Interconnection Assy. Because of the wide separation of G&N components, most interconnection will be accomplished as part of spacecraft wiring.

### G&N Interconnection Harness Assembly

CM BLOCK I Not required.

CM BLOCK II Consists of nine cables that electrically tie together the assemblies that make up the G&N system and interface with the spacecraft.

LEM Not required.

### G&N to S/C Interface Assembly

CM BLOCK I Cable interconnection between the spacecraft wiring channel, the computer connector, and the PSA end connector. Contains no active electronics.

CM BLOCK II Not in Block II.

LEM Not identified yet as a separate item in LEM.

#### Horizon Photometer

CM BLOCK I AND BLOCK II An earth horizon brightness photometer and automatic star tracker used for navigation measurements against the earth's illuminated limb. The sensors are incorporated into the head of the SXT the weight of which includes this function. The PSA includes all support electronics for Block II and some of the support electronics for Block I.

LEM Not a part of LEM.

#### Horizon Photometer Electronics

CM BLOCK I Additional horizon photometer and star tracker electronics mounted on an auxiliary header and attached to the right-hand wall in the lower equipment bay.

CM BLOCK II All electronics are located in the PSA or on the sextant head.

LEM Not required.

#### Horizontal Hand Holds

CM BLOCK I AND CM BLOCK II Hand holds on the G&N Panel for use during navigation sightings. These Hand Holds are a part of the body tethering system for the S/C and will be removed during flight.

LEM Not defined in LEM.

#### Inertial Measurement Unit (IMU)

CM BLOCK I Size 14 IMU (14-inch case diameter) gimbal assembly including all parts inside hermetic case, entrapped coolant, and heat exchanger insulation.

CM BLOCK II AND LEM Size 12.5 IMU is functionally similar to the Block I IMU but not physically interchangeable. Redesigning has eliminated the ADA's, and it now requires a single torque motor per gimble assy.

### IMU Control Panel

CM BLOCK I Consists of panel, wiring, attitude error meter, CDU transfer switch, manual alignment switch, CDU mode control switches, connector, supporting hardware, and associated moisture-proofing.

CM BLOCK II Does not exist in Block II. Moding is done by AGC program and AGC push buttons.

LEM Does not exist in LEM.

### Landing Point Designator

CM Not in CM.

LEM An optical sighting device consisting of a reticle, plane mirror, collimating lens, and a beam splitter to magnify the target area with a light-line reticle pattern.

### Lens Cleaning Kit

CM BLOCK I AND CM BLOCK II Not specially defined but appropriate cloths for cleaning the accessible surfaces of the optics lens.

LEM Not defined in LEM.

### Long-Eye-Relief Eyepieces

CM BLOCK I Consists of a SXT and a SCT eyepiece to provide eye relief of at least 1.6 inches for closed visor operation. Used in place of normal eyepieces of SXT and SCT.

CM BLOCK II Combination eyepiece, regular and long-eye-relief, that has full power and full field of view.

LEM Long-eye-relief eyepieces are included as part of the AOT.

## NVB and Mounts

CM BLOCK I Rigid beryllium structure supporting the IMU and the optical subsystem with its associated hardware. The NVB is attached to the spacecraft using flexible resilient mounts to prevent spacecraft strains from distorting the NVB and the alignment between the IMU and optics. These mounts also provide shock and vibration attenuation.

CM BLOCK II A polyurethane filled aluminum skinned structure functionally similar to Block I but lighter and will provide for mounting the size 12.5 IMU. The Block II NVB is attached to the spacecraft by use of strain isolation hardmounts and will have a transition piece as a result of the re-orientation of the NVB so that the IMU axes will be parallel to the Command Module axes.

LEM A toroidal aluminum ring with: (1) four tubular aluminum posts to provide for IMU mounting, (2) four tubular aluminum posts for AOT mounting, and (3) three aluminum inserts to provide strain isolation ball mounting to the GAEC structure.

## Optical Eyepieces

CM BLOCK I Removable SXT eyepiece and SCT eyepiece.

CM BLOCK II Combination eyepiece, regular and long-eye-relief, that has full power and full field of view.

LEM Included as part of the AOT.

## Optical Subsystem

CM BLOCK I AND CM BLOCK II Consists of SXT, SCT, Optical Base, and associated hardware defined as follows:

- SXT: Sextant: A two-line-of-sight, narrow-field, two-degree-of-freedom sextant and its attached gearing. The horizon photometer and automatic star tracker sensors are incorporated into the SXT head. (See Horizon Photometer Electronics.)
- SCT: Scanning Telescope: A single-line-of-sight, wide-field-of-view, two-degree-of-freedom articulation optical instrument and its attached gearing.
- Optical Base: Base for SXT and SCT with associated gearing.

LEM Not in LEM; see AOT.

#### Optical Shroud & Cover Assembly

CM BLOCK I AND BLOCK II Consists of the optical shroud and protective cover.

LEM Does not exist in LEM.

#### PIPA Electronics Assembly

CM BLOCK I Does not exist separately in Block I.

CM BLOCK II Consists of electronics which directly support the function of the PIPA loop, including the calibration modules, containing selected components, assigned to each IMU. This sealed assembly is located in the Block I CDU location.

LEM Not required.

#### Power Servo Assembly (PSA)

CM BLOCK I Includes most of the support electronics: power supplies; IMU, Optics, and CDU servos; IMU temperature control; accelerometer and gyro pulse torquing; and horizon photometer and automatic star tracker electronics. Consists of 10 trays and replaceable modules which plug into the PSA end connector assembly. Includes a beryllium front toe plate.

CM BLOCK II Similar in function to Block I except that all horizon photometer electronics, D&C electronics, and control electronics are included in the Block II PSA; the CDU servos are deleted also. Electronics to support the PIPA loop have been transferred. See "PIPA Electronics Assembly." Consists of a single plane matrix header, mounted to a cold plate, with the modules plugging onto the top. Many of the modules have been redesigned and repacked.

LEM Consists of electronics similar to those identified in the Block II PSA minus various electronics modules. Does not include optics and photometry electronics associated with the Block I and II PSA's. Also, the LEM PSA does not include electronics for the PIPA and IRIG loops. See "Pulse Torque Assembly."

### PSA End Connector Assembly

CM BLOCK I Electrical interconnection between the PSA trays, the G&N Interconnection Assy, and the G&N to S/C Interface Assy. The End Connector weight is reported in the G&N to S/C Interconnection Assembly weight.

CM BLOCK II AND LEM Not identified as a separate item; will be part of the PSA matrix header.

### PSA Covers

CM BLOCK I Ten plastic connector covers, gaskets, and mounting screws (one for each tray) for moisture-proofing. Weight included in PSA weight value.

CM BLOCK II AND LEM Cover required for moisture-proofing during flight. Weight is reported in PSA weight value.

### Pulse Torque Assembly

CM BLOCK I Does not exist separately in Block I.

CM BLOCK II Not required.

LEM This assembly consists of electronics contained in the PIPA and IRIG loops, including the pulse torque power supply and PIPA and IRIG calibration modules. The PIPA calibration modules, containing selected components, are assigned to each IMU. This sealed assembly is located adjacent to the IMU in LEM.

### Signal Conditioner Assembly

CM BLOCK I Conditions signals for telemetry.

CM BLOCK II These modules are located in the same volume now occupied by the Block I lower equipment bay DSKY.

LEM Same as for Block I.

**CONFIDENTIAL**

Appendix A

**COMPARISON OF ACTUAL WEIGHTS OF DELIVERED G&N SERIES 50 EQUIPMENT  
AND ESTIMATED WEIGHTS FOR G&N 100 SERIES EQUIPMENT**

The following table, Table A-1, presents a comparison between the actual weights of System No. 17 equipment and the estimated weights for G&N 100 series equipment reported in section 2 of this report.

Table A-1. Weight Comparison

	System No. 17 50 Series (lbs)	Weight Estimates 100 Series (lbs)
CDU	14.4	14.1 (M)
Nav Base	37.4	38.4 (M)
Optics*	49.3	54.2 (E)
IMU	59.8	60.5 (C)
PSA	59.0	59.7 (M)
G&N Interconnect†	25.9	27.3 (E)
AGC‡	75.0	87.0 (M)
Optical Shroud	3.1	3.1 (C)
D&C Electronics	2.7	3.0 (E)
Control Electronics	1.9	2.1 (E)
G&N Indicator	10.7	10.5 (E)
IMU Control Panel	2.9	2.8 (E)
D&C/AGC LEB	23.0	23.0 (M)
D&C/AGC MP**	23.0	25.2 (E)
Optics Cover	1.6	1.6 (E)
Coolant Hoses (2)	Not available	0.8 (E)

\*The 100 series Optics Assy includes the additional weight of the Automatic Star Tracker, Horizon Photometer, and associated electronics.

† The G&N Interconnection Assembly for the 100 series system is moisture-proofed and contains an extra cable to the Horizon Photometer Electronics located in the lower equipment bay.

‡ The AGC for the 100 series system includes the weight of the G&N to S/C Interface Cable Assembly, not included in the 50 series system AGC.

\*\*The D&C/AGC MP includes the additional weight of a piece of fail-safe alarm detection equipment termed "nightwatchman."

NOTE: Basic changes in the 100 series Block I G&N system include: (1) redesigned packaging of the flight computer, (2) modification of the electronics packaging to achieve moisture-proofing and to correct deficiencies in the S&ID thermal interface material, (3) less flammable wiring insulation, and (4) addition of insulation to the cold surfaces.



DISTRIBUTION LIST

E-1142, Rev. 34

Apollo Internal

Apollo Library (5)	Hickey, E.	Nevins, J.
Battin, R.	Hoag, D.	Nugent, J.
Bean, W.	Houston, F.	Olsson, E.A.
Bowditch, P.	Hursh, J.	Schwarm, E.
Boyce, A.	Johnson, L.	Sciegienny, J.
Dahlen, J.	Koso, A.	Sears, N.
Dunipace, E.	Kramer, M.	Stameris, W.
Duggan, E.	Larson, L.	Stone, J.
Feldman, J.B.	Lawrence, J. (GAEC)	Trageser, M.
Flanders, J.	Lawton, T.J.	Watson, P.
Felix, S. (S&ID)	Mayo, G.	Wilk, L. (2)
Hall, E.C.	Miller, J.	Woodbury, R.
Halzel, I.	MIT/IL (Library) (IL-1) (8)	

External

P. Ebersole (NASA/MSC)	(2)	Kollsman	(1)
W. Rhine (NASA/RASPO)	(1)	AC Spark Plug	(1)
L. Holdridge (NAA/MIT)	(1)	Major W. Delaney (AFSC/MIT)	(1)
T. Heuermann (GAEC/MIT)	(1)	Raytheon	(1)

MSC: National Aeronautics and Space Administration (30 + 1R)  
Manned Spacecraft Center  
Apollo Document Distribution Office (PA2)  
Houston, Texas 77058

KSC: National Aeronautics and Space Administration (1R)  
J.F. Kennedy Space Center  
Attn: Technical Document Control Office HB-23  
Cape Kennedy, Florida

GAEC: Grumman Aircraft Engineering Corporation (1)  
Bethpage, Long Island, New York  
Attn: Mr. A. Whitaker

NAA: North American Aviation, Inc. (1R)  
Space and Information Systems Division  
12214 Lakewood Boulevard  
Downey, California  
Attn: Apollo Data Requirements AE99  
Dept. 41-096-704

ACSP RASPO: National Aeronautics and Space Administration (1)  
Resident Apollo Spacecraft Program Officer  
Dept. 32-31  
AC Spark Plug Division of General Motors  
Milwaukee 1, Wisconsin  
Attn: Mr. W. Swingle

Mr. H. Peterson (1)  
Bureau of Naval Weapons  
c/o Raytheon Company  
Foundry Avenue  
Waltham, Massachusetts

Queens Material Quality Section (1)  
c/o Kollsman Instrument Corporation  
Building A 80-08 45th Avenue  
Elmhurst, New York 11373  
Attn: Mr. S. Schwartz

Mr. H. Anschuetz (1)  
USAF Contract Management District  
AC Spark Plug Division of General Motors  
Milwaukee 1, Wisconsin 53201