

40M33627B  
DECEMBER 5, 1967



**GEORGE C. MARSHALL** **SPACE  
FLIGHT  
CENTER**

SATURN HISTORY DOCUMENT  
University of Alabama Research Institute  
History of Science & Technology Group

Date                      Doc. No.                     

# INTERFACE CONTROL DOCUMENT DEFINITION OF SATURN SA-507 FLIGHT SEQUENCE PROGRAM

## REPOSITORY ISSUE

PREPARED BY:  
AIRBORNE ELECTRICAL SYSTEMS BRANCH  
ELECTRICAL SYSTEMS INTEGRATION DIVISION  
ASTRONICS LABORATORY  
MARSHALL SPACE FLIGHT CENTER

NATIONAL AERONAUTICS AND SPACE ADMINISTRATION



EFFECTIVE ON: SA 507 & Subs

40M33627B

DEFINITION OF SATURN SA-507 & SUBS  
FLIGHT SEQUENCE PROGRAM

F						
E						
D						
C						
B	501-9-0454 <i>7/29/69</i>		<i>J. L. Felch</i>	8-4-69	<i>Edmund Youngblood</i>	9-4-69
A	J. L. Felch	3-14-69	John D. Stroud	3-17-69	Phil Youngblood	3-17-69
ORIG	J. L. Felch	11-30-67	John D. Stroud	11-30-67	Phil Youngblood	12-4-67
	NAME	DATE	NAME	DATE	NAME	DATE
	SUBMITTED		APPROVED		APPROVED	

PREPARED FOR: ELECTRICAL WORKING GROUP

SATURN INTERFACE  
CONTROL DOCUMENT

# SATURN INTERFACE CONTROL DOCUMENT CHANGE/REVISION RECORD

40M33627B

CHANGE/ REVISION	DATE	DESCRIPTION	SHEET	
			REVISION	ADDED
Revision A	3/22/69	Incorporated IRN's 1 thru 28  Revised document to meet the re- quirements of the AS-507 "G" mission.  Renumbered pages.  Revised table of contents.	Entire Document	
Revision B	6/27/69	Incorporated IRN's 29 thru 41	Entire Document	

## TABLE OF CONTENTS

	Page
I. INTRODUCTION	1
II. DEFINITION OF TIME BASES FOR THE TIME SEQUENCING OF SA-507 & SUBS	1
A. GENERAL	1
B. TIME BASE #1 (T <sub>1</sub> )	2
C. TIME BASE #2 (T <sub>2</sub> )	2
D. TIME BASE #3 (T <sub>3</sub> )	2
E. TIME BASE #4 (T <sub>4</sub> )	2
F. TIME BASE #5 (T <sub>5</sub> )	3
G. TIME BASE #6 (T <sub>6</sub> )	3
H. TIME BASE #7 (T <sub>7</sub> )	3
I. TIME BASE #8 (T <sub>8</sub> )	3
J. ALTERNATE TIME BASE #4a (T <sub>4a</sub> )	4
K. ALTERNATE TIME BASE #6a (T <sub>6a</sub> )	4
L. ALTERNATE TIME BASE #6b (T <sub>6b</sub> )	4
M. ALTERNATE TIME BASE #6c (T <sub>6c</sub> )	4
N. ADDITIONAL SA-507 & SUBS SEQUENCE REQUIREMENTS	5
1. NOTE 1	5
2. NOTE 2	5
3. NOTE 3	5
III. LVDA DISCRETE OUTPUTS, INPUTS AND INTERRUPTS	5
A. LVDA DISCRETE OUTPUTS	6
B. LVDA DISCRETE INPUTS	7
C. LVDA INTERRUPTS	9

## TABLE OF CONTENTS (Continued)

	Page
IV. ABBREVIATIONS	10
V. LOGIC DIAGRAMS	10
VI. CHANGES	11
VII. FLIGHT SEQUENCE PROGRAM	24 - 60
VIII. SWITCH SELECTOR CHANNELS WIRED IN VEHICLE BUT NOT PROGRAMMED FOR USE DURING FLIGHT	61 - 63

## GEORGE C. MARSHALL SPACE FLIGHT CENTER

---

DEFINITION OF SATURN SA-507 & SUBS  
FLIGHT SEQUENCE PROGRAM

---

## I. INTRODUCTION

The purpose of this document is to define the flight sequence events, time bases, stage switch selector channel assignments, LVDA Discrete Outputs, Inputs and Interrupts for the Saturn SA-507 & Subs vehicles. Special requirements and restrictions defined in this document will be imposed on the Marshall Space Flight Center and its contractors as applicable, to insure the proper functioning of the equipment in the various stages for required vehicle timing and sequencing to occur as outlined in this Interface Control Document (ICD).

## II. DEFINITION OF TIME BASES FOR THE TIME SEQUENCING OF SA-507 &amp; SUBS

## A. General

Eight (8) primary time bases are used in this SA-507 & Subs Vehicle Flight Sequence Program in order to achieve an optimum vehicle mission with suitable sequential operation and timing of flight vehicle events. Four (4) alternate time bases are also programmed for use should a need arise.

Safeguards are used where necessary to prevent premature initiation of time bases.

Proper establishment of time bases provides a safe and reliable vehicle on the pad and throughout the flight. Each time base will be established by the normal method when the required criteria, as outlined in this ICD, has been received by the Launch Vehicle Digital Computer (LVDC).

If a time base is not established, subsequent time bases cannot be started and the vehicle mission cannot be completed. Therefore, to further increase mission reliability in the absence of the normal time base signals, backup methods are used for establishing time bases.

Both the normal and backup methods for starting each time base are explained in the following paragraphs.

#### B. Time Base #1 ( $T_1$ )

Time Base #1 ( $T_1$ ) is initiated by a liftoff signal provided by the deactuation of the liftoff relay in the IU at the umbilical disconnect. However, as a safety measure, the Launch Vehicle Digital Computer (LVDC) will not recognize the liftoff signal and start  $T_1$  prior to receiving Guidance Reference Release plus 16.0 seconds (Liftoff -1.0 second).

A backup method for starting  $T_1$  is provided should the LVDC fail to receive or recognize the liftoff signal. If  $T_1$  is not initiated within 17.5 seconds after Guidance Reference Release, the LVDC shall monitor the vertical accelerometer. If a significant positive acceleration (in excess of 1 g.) exists, the LVDC assumes liftoff has occurred and begins  $T_1$ . A time adjustment is made by the computer.

No "Negative Backup" (i.e., provisions for the LVDC to return to prelaunch conditions) is provided because the Saturn V vehicle could safely complete  $T_1$  on the pad without catastrophic results, in the event  $T_1$  began by error.

#### C. Time Base #2 ( $T_2$ )

The S-IC inboard engine shall be cutoff by the LVDC through the S-IC switch selector at a predetermined time on Time Base #1 ( $T_1 + 134.6$ ). At this time, the LVDC shall monitor the downrange accelerometer. If sufficient downrange velocity exists, the LVDC shall start Time Base #2 ( $T_2$ ).

Use of the downrange velocity reading provides a safeguard against starting  $T_2$  on the pad should  $T_1$  be started without liftoff. Furthermore if  $T_2$  is not established, no subsequent time bases can be started. This insures a safe vehicle requiring at least one additional failure to render the vehicle unsafe on the pad.

#### D. Time Base #3 ( $T_3$ )

After arming the S-IC outboard engines propellant depletion cutoff sensors through the S-IC switch selector, the LVDC shall initiate Time Base #3 ( $T_3$ ) upon receiving either of two redundant outboard engines cutoff signals. The S-IC Outboard Engines Cutoff "A" signal (INT 5) from the S-IC depletion circuitry is the primary signal for starting  $T_3$ . The S-IC Outboard Engines Cutoff "B" signal (DIN 18) from the backup depletion circuitry is a backup signal.

#### E. Time Base #4 ( $T_4$ )

After arming the S-II LOX depletion cutoff sensors through the S-II switch selector, the LVDC shall initiate Time Base #4 ( $T_4$ ) upon receiving either of two signals, S-II Engines Cutoff or S-II Engines Out. The S-II engines cutoff signal from the S-II depletion cutoff circuitry is the primary signal for starting  $T_4$ . The S-II engines out signal from the thrust OK circuitry is a backup.

#### E. Time Base #4 (T<sub>4</sub>)

A redundant S-II Engines cutoff command is issued at the start of T<sub>4</sub> (T<sub>4</sub> + 0.1), as a safeguard against having started T<sub>4</sub> with the thrust of the S-II engines present.

#### E. Time Base #5 (T<sub>5</sub>)

After a predetermined time on T<sub>4</sub> or T<sub>4a</sub> (T<sub>4</sub> + 10.0 or T<sub>4a</sub> + 15.0), sufficient to allow the S-IVB engine to establish thrust OK, the LVDC shall start T<sub>5</sub> after receiving any two of four functions monitored by the LVDC. The functions are (1) S-IVB Engine Out "A" (2) S-IVB Engine Out "B" (3) S-IVB Velocity Cutoff which is issued by the LVDC through the S-IVB switch selector (4) Loss of thrust determined by LVDC using accelerometer readings.

A redundant S-IVB engine cutoff command is issued at the start of T<sub>5</sub> (T<sub>5</sub> + 0.1) as a safeguard against having started T<sub>5</sub> with the thrust of the S-IVB engine present.

#### G. Time Base #6 (T<sub>6</sub>)

After a predetermined time on Time Base #5, Time Base #6 shall be initiated by the LVDC upon solving the restart equation. The starting of Time Base #6 can be inhibited by the "Translunar Injection Inhibit" signal (DIN6) from the spacecraft.

The starting of Time Base #6 can also be inhibited during Time Base #5 by use of a DCS inhibit command. However, once this DCS inhibit is set, it cannot be removed to allow start of Time Base #6.

#### H. Time Base #7 (T<sub>7</sub>)

After a predetermined time, sufficient to allow the S-IVB Engine to establish Thrust OK (T<sub>6</sub> + 584.0 sec.) the LVDC shall start T<sub>7</sub> after receiving any two of four functions monitored by the LVDC. The functions are (1) S-IVB Engine Out "A" (2) S-IVB Engine Out "B" (3) S-IVB Velocity Cutoff which is issued by the LVDC through the S-IVB switch selector (4) Loss of thrust determined by the LVDC using accelerometer readings.

A redundant S-IVB Engine Cutoff command is issued at the start of T<sub>7</sub> (T<sub>7</sub> + 0.1) as a safeguard against having started T<sub>7</sub> with the thrust of the S-IVB engine present.

#### I. Time Base #8 (T<sub>8</sub>)

The starting of Time Base #8 shall be inhibited in the LVDC. This inhibit must be removed by DCS command prior to LVDC initiation of Time Base #8.



If this LVDC inhibit (S-IVB Propellant Dump Inhibit) is removed after  $T_7 + 7200.0$  seconds, the LVDC shall initiate Time Base #8.

J. Alternate Time Base #4a ( $T_{4a}$ )

Alternate Time Base #4a ( $T_{4a}$ ) shall be programmed for use in early staging of the S-IVB stage. This time base shall be initiated by the LVDC upon receiving either of two signals, S/C Initiation of S-II/S-IVB Separation "A" or S/C Initiation of S-II/S-IVB Separation "B". The starting of  $T_{4a}$  shall be inhibited until  $T_3 + 1.4$  seconds.

K. Alternate Time Base #6a ( $T_{6a}$ )

Alternate Time Base #6a ( $T_{6a}$ ) shall be programmed for use should the  $O_2-H_2$  burner malfunction between the times  $T_6 + 48.0$  seconds to  $T_6 + 341.3$  seconds. This alternate time base shall be initiated by the LVDC upon receiving "O<sub>2</sub>-H<sub>2</sub> Burner Malfunction" signal (DIN 3) from the S-IVB stage. After completion of this alternate sequence, the LVDC shall return to Time Base #6.

L. Alternate Time Base #6b ( $T_{6b}$ )

Alternate Time Base #6b ( $T_{6b}$ ) shall be programmed for use should the  $O_2-H_2$  burner malfunction between the time  $T_6 + 341.3$  seconds to  $T_6 + 496.7$  seconds. This alternate time base shall be initiated by the LVDC upon receiving a "O<sub>2</sub>-H<sub>2</sub> Burner Malfunction" signal (DIN 3) from the S-IVB stage. After completion of this alternate sequence, the LVDC shall return to Time Base #6.

M. Alternate Time Base #6c ( $T_{6c}$ )

Alternate Time Base #6c ( $T_{6c}$ ) shall be programmed for use should a failure occur which would require a delay in the S-IVB restart attempt. The spacecraft "Translunar Injection Inhibit" signal (DIN 6) shall be required by the LVDC before this alternate time base shall be initiated.

The LVDC shall be programmed to look for the Translunar Injection Inhibit signal at  $T_6 + 41.0$  seconds, at which time  $T_{6c}$  shall be initiated if the signal is present.

The LVDC shall also be programmed to look for the Translunar Injection Inhibit signal at  $T_6 + 497.3$  and then once per computer cycle ( $\approx$  once per second) between the times  $T_6 + 497.3$  and  $T_6 + 560.0$  seconds. If the signal is present the LVDC shall initiate  $T_{6c}$ .

Upon completion of Time Base #6c, the LVDC shall return to Time Base #5 updated by the time elapsed in Time Base #6 and Alternate Time Base #6c.

#### N. Additional SA-507 & Subs Sequence Requirements

a. The IU telemetry and S-IVB telemetry shall be calibrated after first insertion by using a special sequence. This special sequence of events consists of IU and S-IVB Telemetry Calibration Commands and shall be initiated by the LVDC using special tracking station acquisition logic. The first telemetry calibrate command shall be issued 60.0 seconds after station acquisition as determined by the LVDC.

b. The S-II Stage Mixture Ratio Shift from 5.5 to 4.5 shall be initiated by the LVDC based on Program Logic (When  $T_{1i} = 0$ ). On SA-507, this MR Shift shall occur when  $T_3 = (\text{IGM initiated} + T_{1i})$  seconds + a comp cycle, -0.

Since  $T_{1i}$  is changed for S-II Engine out, this logic delays the MR Shift and provides for TLI capability with one S-II Engine out.

##### Note 1

During the S-IVB first burn the LVDC is programmed to initiate an S-IVB engine purge by issuing the command "Engine Pump Purge Control Valve Enable On" through the switch selector 9.0 seconds  $\pm$  1.0 second prior to velocity cutoff of the S-IVB engine. The purpose of this purge is to remove the moisture in the seal cavities.

##### Note 2

After liftoff plus 480 seconds the water coolant valve shall be switched open or closed by the LVDC through the IU switch selector. The LVDC shall be programmed to open the coolant valve when either of two thermal switches mounted in the water/methanol system close and to close the valve when both of the switches are open. This shall not interfere with other events in the flight sequence.

##### Note 3

If Alternate Time Base 6c ( $T_{6c}$ ) is initiated by the spacecraft after  $T_6 + 41.3$  seconds, all functions which are followed by the notation "See Note 3" on Time Base #6 will not be issued by the LVDC during the second S-IVB restart attempt.

#### III. LVDA DISCRETE OUTPUTS, INPUTS AND INTERRUPTS

The following tables list the LVDA Discrete Outputs, Discrete Inputs and Interrupts used on this vehicle to accomplish the flight sequencing program as defined in this Interface Control Document.

## A. LVDA DISCRETE OUTPUTS

<u>LVDA Connector &amp; Pin Number</u>	<u>Function</u>
J17 <u>h</u>	Reset Command Decoder
J13J	Reset RCA 110A
J13 <u>e</u>	RCA 110A Interrupt
J4AA	Spare (Wired to Control Distributor)
J2EE	Guidance Failure "A"
J2 <u>u</u>	Spare (Wired to Control Distributor)
J2 <u>c</u>	Guidance Failure "B"
J2G	Spare (Wired to Control Distributor)
J4 <u>m</u>	Spare (Wired to Control Distributor)
J4 <u>a</u>	Spare (Wired to Control Distributor)
J4 <u>d</u>	Spare (Wired to Control Distributor)
J4 <u>e</u>	Spare (Wired to Control Distributor)
J4 <u>f</u>	LVDA/LVDC Firing Commit Enable
J4S	LVDA/LVDC Firing Commit Inhibit
J4C	Switch Selector Address First Digit
J4B	Switch Selector Address Second Digit
J4A	Switch Selector Address Third Digit
J4D	Switch Selector Address Fourth Digit
J4Y	Switch Selector Address Fifth Digit
J4X	Switch Selector Address Sixth Digit
J4W	Switch Selector Address Seventh Digit

## A. LVDA DISCRETE OUTPUTS (Continued)

<u>LVDA Connector &amp; Pin Number</u>	<u>Function</u>
J4V	Switch Selector Address Eighth Digit
J4p	Switch Selector Read
J4n	Switch Selector Read
J4U	Switch Selector Register Reset
J4T	Switch Selector Register Reset
J4r	S-IC Switch Selector Enable
J4q	S-IC Switch Selector Enable
J4Z	S-II Switch Selector Enable
J4E	S-II Switch Selector Enable
J4J	S-IVB Switch Selector Enable
J4F	S-IVB Switch Selector Enable
J4CC	IU Switch Selector Enable
J4BB	IU Switch Selector Enable
J4K	Spare (Switch Selector Enable, SS-12D)
J4s	Spare (Switch Selector Enable, SS-12)

## B. LVDC DISCRETE INPUTS

<u>LVDA Connector &amp; Pin Number</u>	<u>Function</u>
J13h	RCA 110A Sync
J17X	Command Decoder OM/D "A"
J17Y	Command Decoder OM/D "B"

## B. LVDA DISCRETE INPUTS (Continued)

<u>LVDA Connector &amp; Pin Number</u>	<u>Function</u>
J2BB	O <sub>2</sub> -H <sub>2</sub> Burner Malfunction
J2CC	Spare (Wired to EDS Distributor)
J2e	S-IVB Engine Out "A"
J2a	Translunar Injection Inhibit
J8i	Spare (Wired to ESE)
J8N	Spare (Wired to ESE)
J2F	S/C Control of Saturn
J2t	S-II/S-IVB Separation
J2n	S-IC Inboard Engine Out "B"
J2p	S-IC/S-II Separation
J2q	S-II Inboard Engine Out
J2r	S-IC Outboard Engine Out
J2Z	S-II AFT Interstage Separation
J2E	Prepare for Guidance Reference Release
J2U	S-IC Inboard Engine Out "A"
J2X	S-IC Outboard Engine Cutoff "B"
J2V	S-II Engines Out
J2W	S-IVB Ignition Sequence Start
J4N	S-II Outboard Engine Out
J4M	S/C Initiation of S-II/S-IVB Separation "B" or S-IVB Engine Cutoff "B" (See Note *)

## B. LVDA DISCRETE INPUTS (Continued)

<u>LVDA Connector &amp; Pin Number</u>	<u>Function</u>
J4L	S/C Initiation of S-IVB Engine Cutoff
J2s	Liftoff
J4b	Switch Selector Address Verification First Digit
J4t	Switch Selector Address Verification Second Digit
J4DD	Switch Selector Address Verification Third Digit
J4EE	Switch Selector Address Verification Fourth Digit
J4u	Switch Selector Address Verification Fifth Digit
J4c	Switch Selector Address Verification Sixth Digit
J4G	Switch Selector Address Verification Seventh Digit
J4H	Switch Selector Address Verification Eighth Digit
J2AA	Coolant Thermal Switch #1
J2m	Coolant Thermal Switch #2

Note\*: During Time Base #3 (S-II Burn) this Discrete Input and Interrupt shall be used to initiate S-II/S-IVB Separation. After S-II Engines Cutoff this Discrete Input and Interrupt shall be used to initiate S-IVB Engine Cutoff.

## C. LVDA INTERRUPTS

<u>LVDA Connector &amp; Pin Number</u>	<u>Function</u>
J8BB	Command LVDA/RCA 110 Interrupt
J2B	S/C Initiation of S-II/S-IVB Separation "A" or S-IVB Engine Cutoff "A" (See Note *)
J8g	RCA 110A Interrupt

## C. LVDA INTERRUPTS (Continued)

<u>LVDA Connector &amp; Pin Number</u>	<u>Function</u>
J2C	S-IVB Engine Out "B"
J2A	S-IC Outboard Engines Cutoff "A"
J2D	S-II Engines Cutoff
J2Y	Guidance Reference Release
J17A	Command Decoder Interrupt "A"
J17B	Command Decoder Interrupt "B"
Internal	TLC - Simulanteous Memory Error
J18G	Data Ready from C.I.U.
Internal	Switch Selector Interrupt
Internal	Minor Loop Interrupt

## IV. ABBREVIATIONS

EDS	Emergency Detection System
FM	Frequency Modulation
ICD	Interface Control Document
IU	Instrument Unit
L.E.T.	Launch Escape Tower
LH <sub>2</sub>	Liquid Hydrogen
LOX	Liquid Oxygen
LVDC	Launch Vehicle Digital Computer
LV/SC	Launch Vehicle/Spacecraft
PAM	Pulse Amplitude Modulation
P.U.	Propellant Utilization
S/S	Single Side Band
TBD	To Be Determined
MR	Mixture Ratio

## V. LOGIC DIAGRAMS

The logic diagrams, pages 12 through 22 indicate the conditions that must exist before initiation of each time base programmed for use on the AS-507 & Subs mission. Logic diagram, page 23 indicates conditions that must exist for water valve cycling.

## VI. CHANGES

As requirements change and as the need arises, changes will be approved and released against this document and revisions to incorporate these changes will follow. Questions and requests for changes by all parties concerned should be put in writing and directed to S&E-CSE-GA, Marshall Space Flight Center, Alabama 35812. The telephone number for S&E-CSE-GA is 453-1645.



V. LOGIC DIAGRAMS

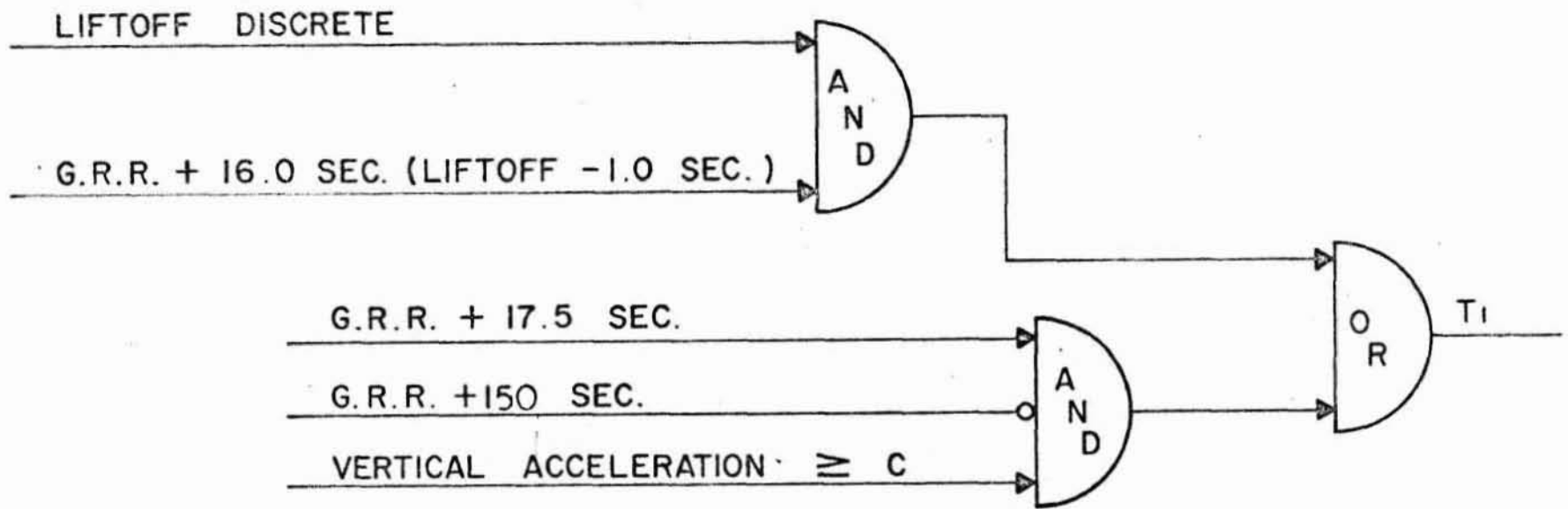

TIME BASE # 1

40M33627B

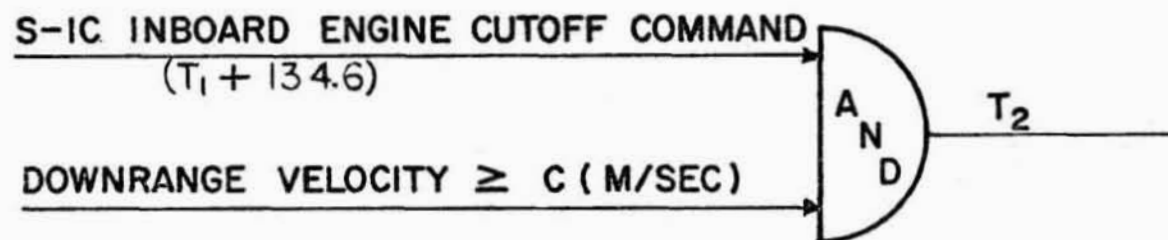

TIME BASE #2

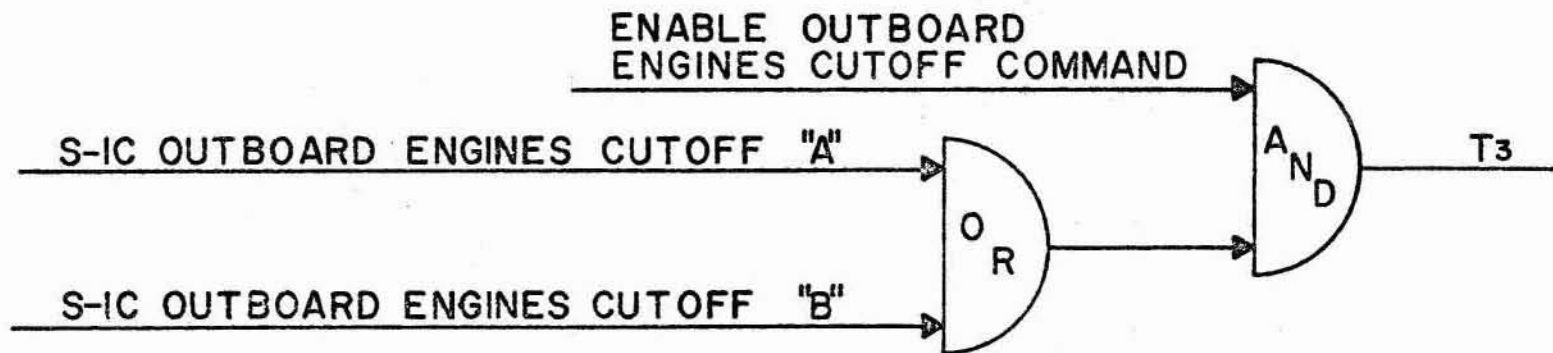

TIME BASE #3

40M33627B

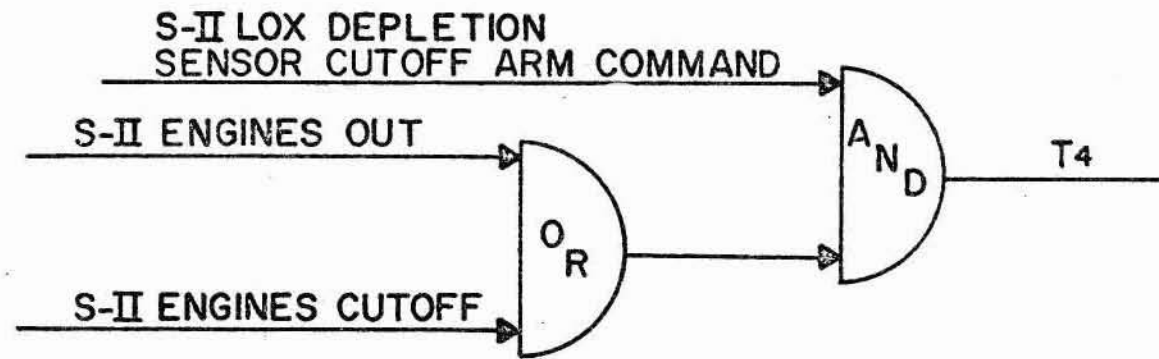

TIME BASE #4

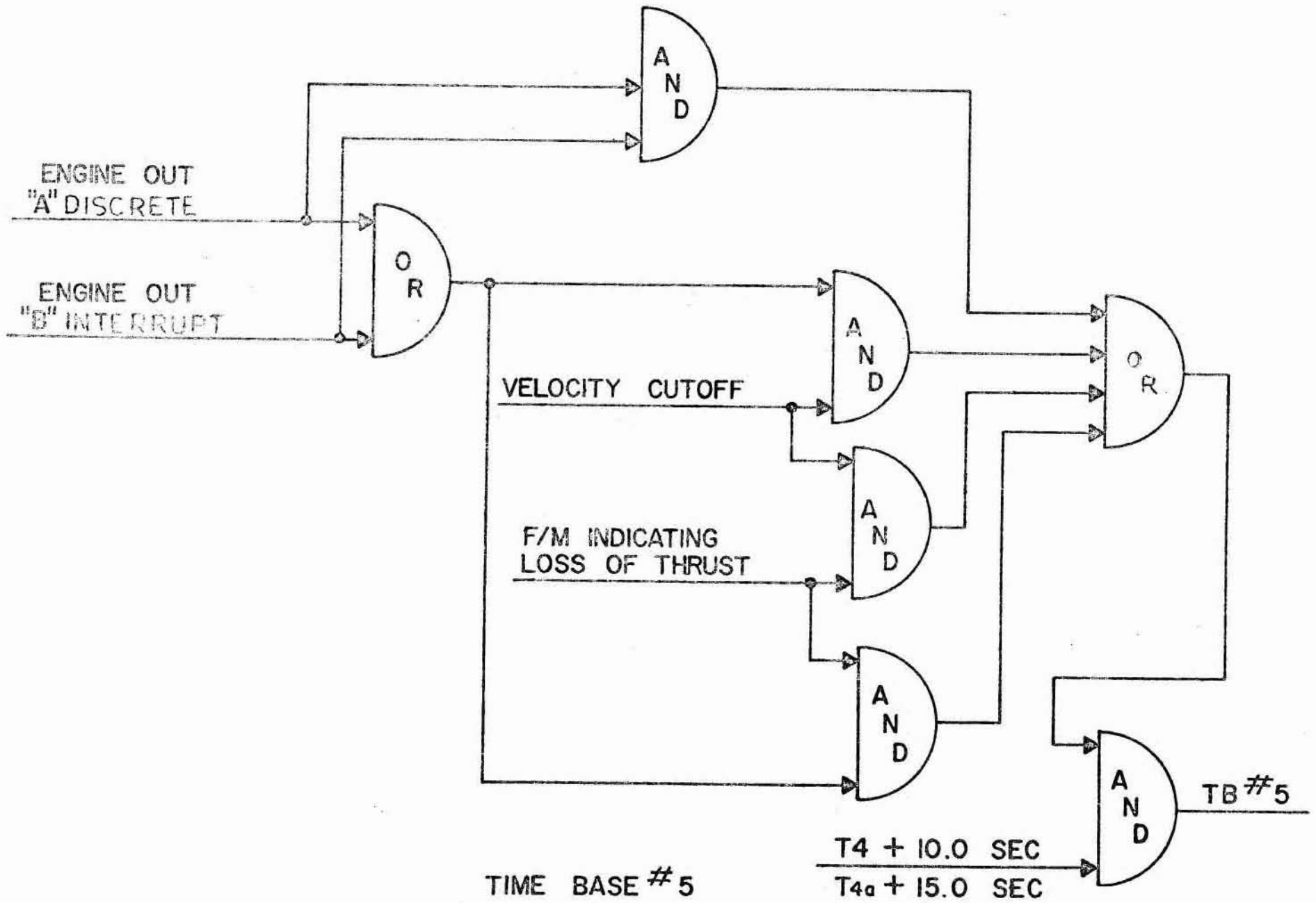

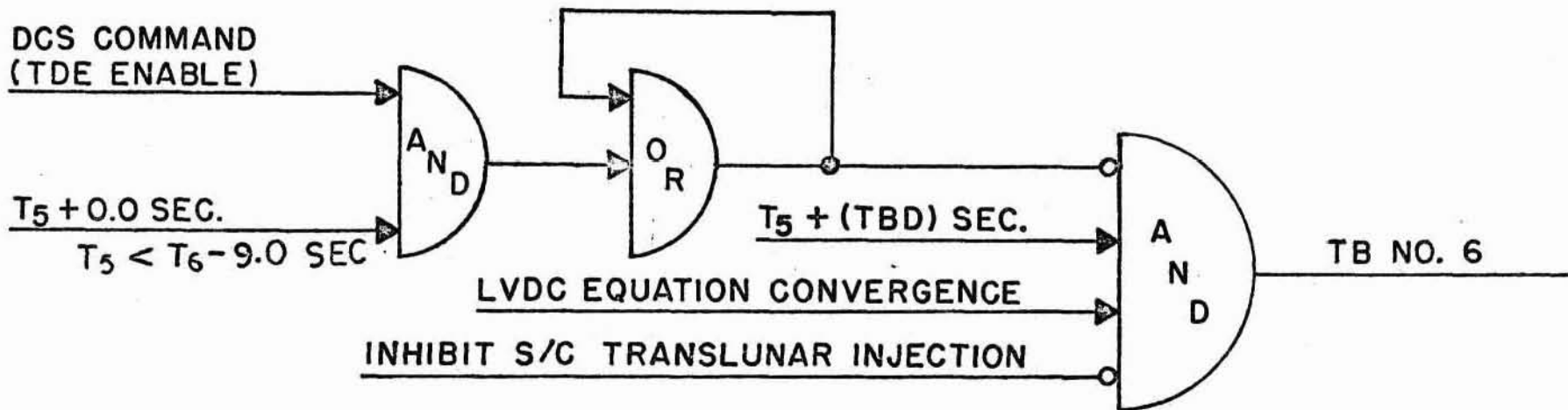

TIME BASE NO. 6

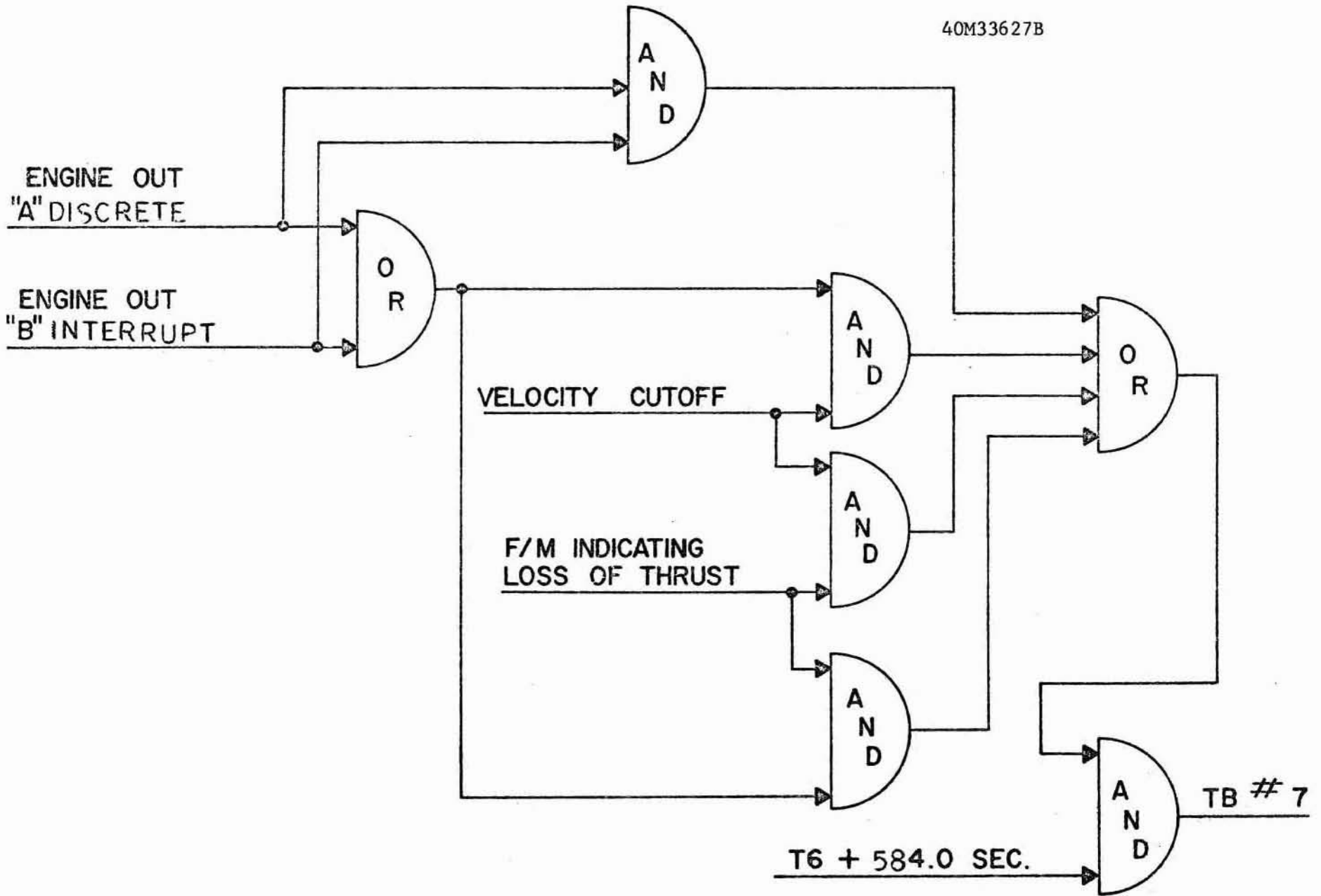

TIME BASE # 7



40M33627B

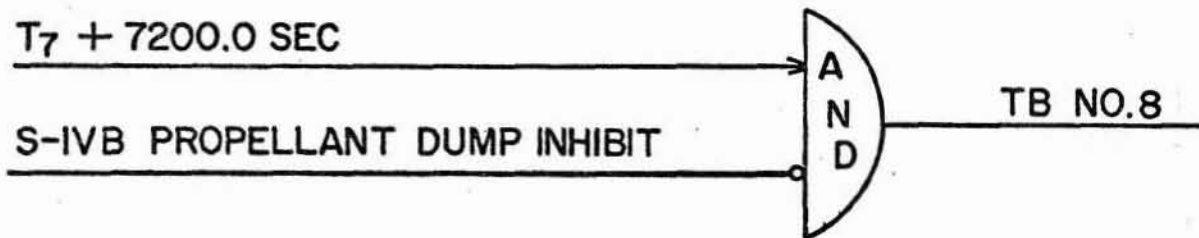

TIME BASE NO. 8

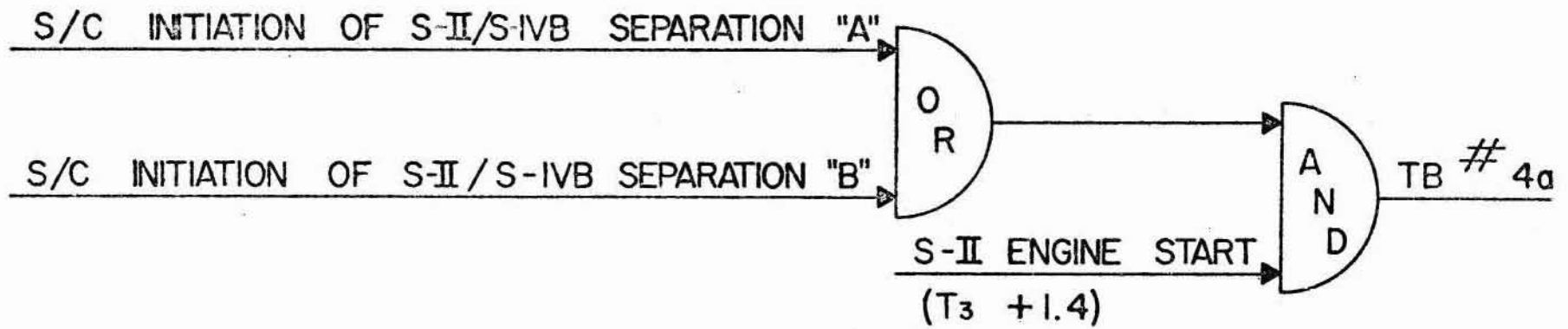

TIME BASE # 4a

40M33627B

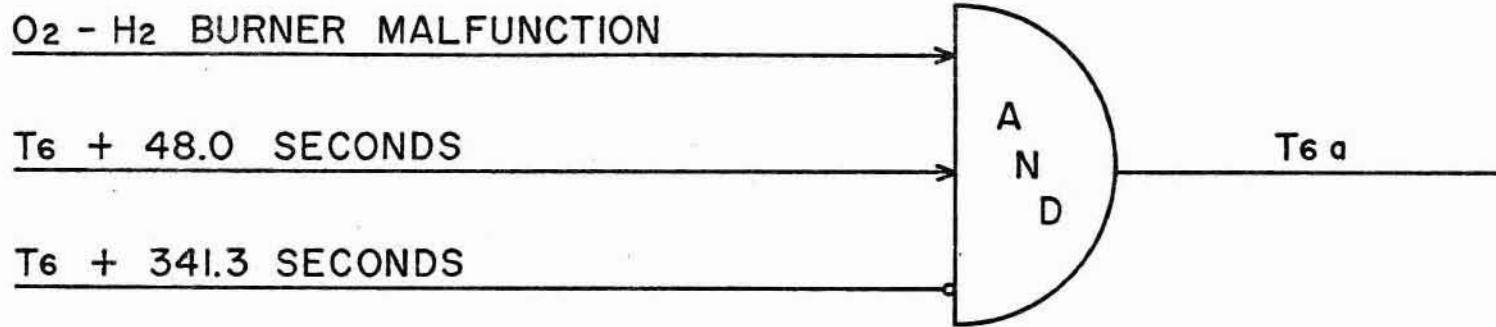

TIME BASE NO. 6 a

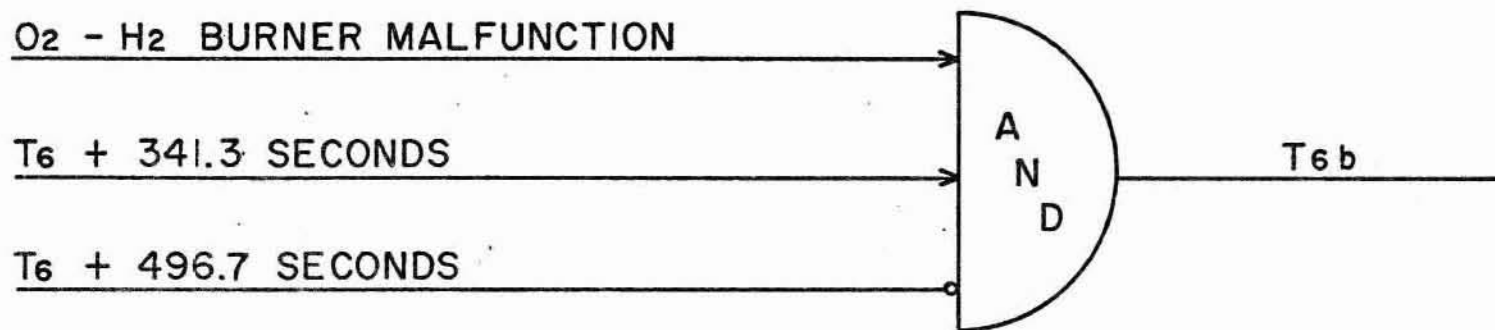

TIME BASE NO. 6 b

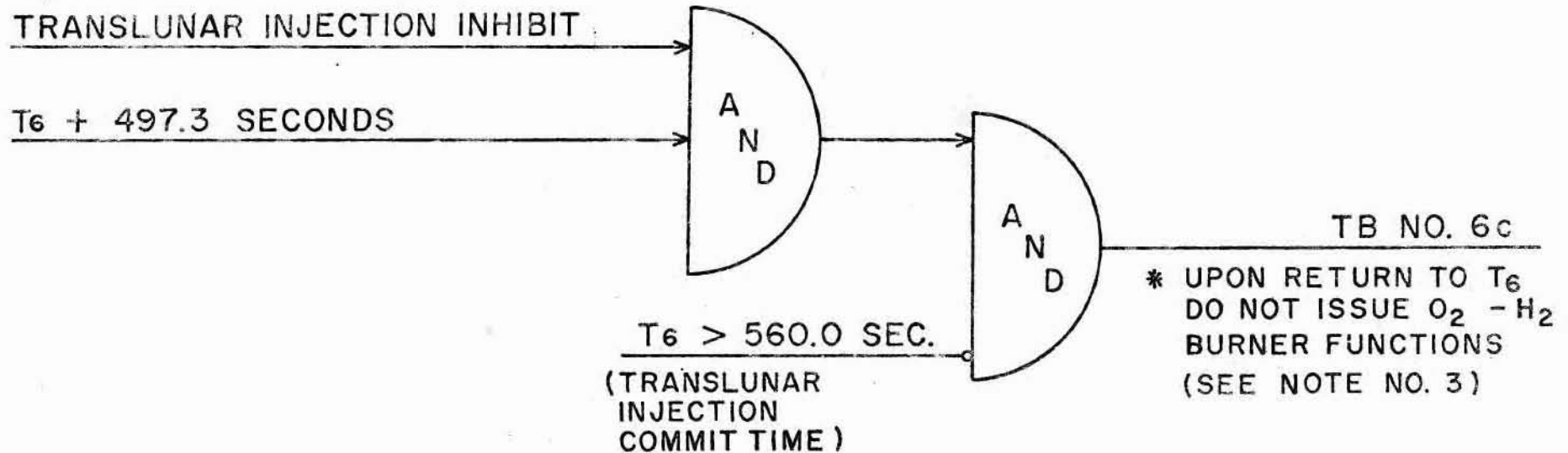
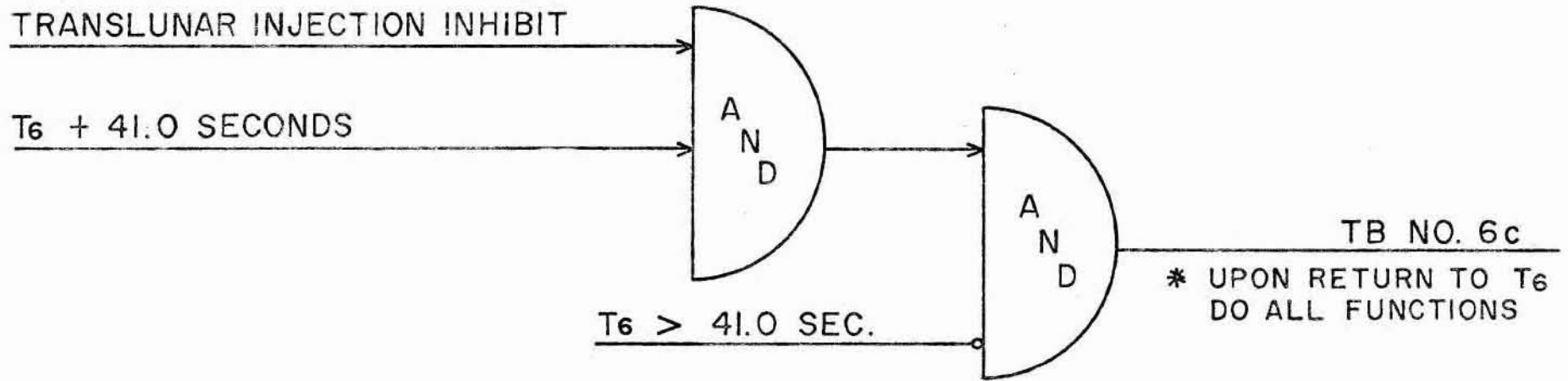

TIME BASE NO. 6c

40M33627B

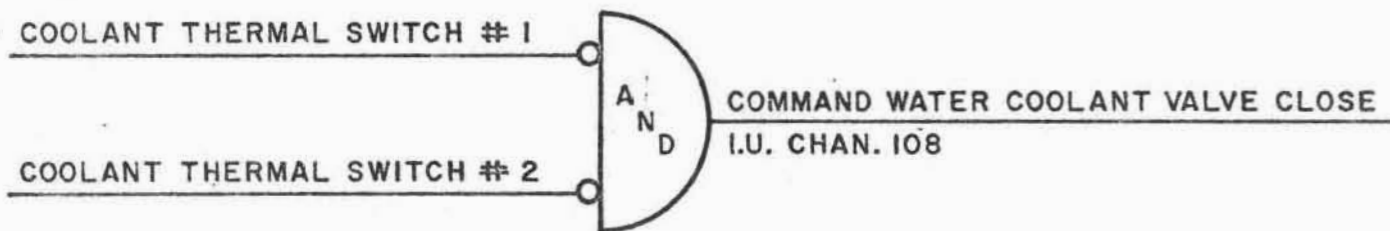
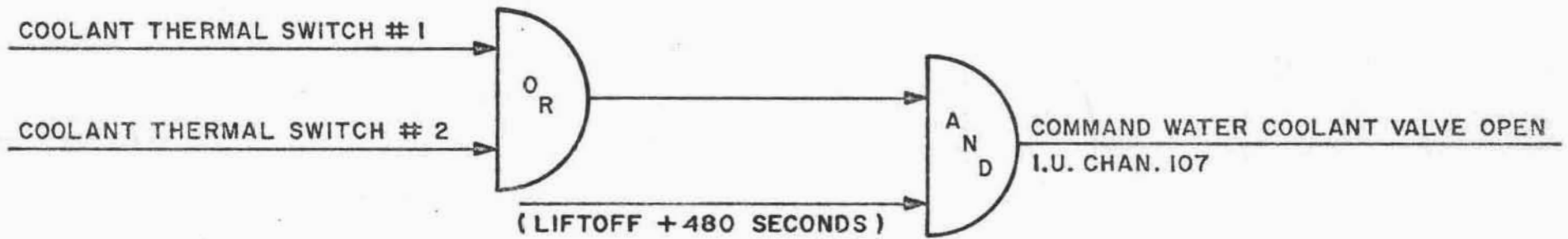

## ECS WATER COOLANT VALVE LOGIC

VII. FLIGHT SEQUENCE PROGRAM

NOMINAL FLIGHT TIME HR MIN SEC	COMMAND	SWITCH SELECTOR			TIME FROM BASE SECONDS
		CODE	STAGE	CHN	
00:00:00.0	LIFTOFF - START OF TIME BASE NO. 1 (T1)				T1 + .0
00:00:05.0	SENSOR BIAS ON	0001 0101	IU	109	T1 + 5.0
00:00:06.0	L0X TANK PRESSURIZATION SHUTOFF VALVES CLOSE ON	0110 1010	SIVB	79	T1 + 6.0
00:00:14.0	MULTIPLE ENGINE CUTOFF ENABLE	0110 0010	S-IC	3	T1 + 14.0
00:00:19.8	S-IC OUTBOARD ENGINES CANT ON 'A'	0110 1001	IU	83	T1 + 19.8
00:00:20.0	S-IC OUTBOARD ENGINES CANT ON 'B'	0101 1001	IU	84	T1 + 20.0
00:00:20.2	S-IC OUTBOARD ENGINES CANT ON 'C'	0110 0111	IU	85	T1 + 20.2
00:00:24.0	TELEMETER CALIBRATE ON	0101 1111	S-IC	2	T1 + 24.0
00:00:27.0	TELEMETRY CALIBRATOR IN-FLIGHT CALIBRATE ON	0010 0010	IU	23	T1 + 27.0
00:00:29.0	TELEMETER CALIBRATE OFF	0111 1111	S-IC	1	T1 + 29.0
00:00:30.0	LAUNCH VEHICLE ENGINES EDS CUTOFF ENABLE	0011 0001	IU	38	T1 + 30.0
00:00:32.0	TELEMETRY CALIBRATOR IN-FLIGHT CALIBRATE OFF	0001 0010	IU	24	T1 + 32.0
00:00:49.5	FUEL PRESSURIZING VALVE NO.2 OPEN	0000 0010	S-IC	5	T1 + 49.5
00:01:15.0	COOLING SYSTEM ELECTRONIC ASSEMBLY POWER OFF	0011 0100	IU	110	T1 + 75.0

40M33627B

NOMINAL FLIGHT TIME HR MIN SEC	COMMAND	SWITCH SELECTOR			TIME FROM BASE SECONDS	
		CODE	STAGE	CHN		
00:01:30.0	TELEMETRY CALIBRATOR IN-FLIGHT CALIBRATE ON	0010 0010	IU	23	T1 +	90.0
00:01:35.0	TELEMETRY CALIBRATOR IN-FLIGHT CALIBRATE OFF	0001 0010	IU	24	T1 +	95.0
00:01:35.3	FUEL PRESSURIZING VALVE NO. 3 OPEN	0010 1101	S-IC	6	T1 +	95.3
00:01:45.0	FLIGHT CONTROL COMPUTER SWITCH POINT NO. 1	0111 1101	IU	26	T1 +	105.0
00:01:55.1	TELEMETER CALIBRATE ON	0101 1111	S-IC	2	T1 +	115.1
00:01:59.8	EXCESS RATE (P,Y,R) AUTO-ABORT INHIBIT ENABLE	0110 1111	IU	15	T1 +	119.8
00:02:00.0	EXCESS RATE (P,Y,R) AUTO-ABORT INHIBIT AND SWITCH RATE GYRO'S SC INDICATION 'A'	0101 1111	IU	2	T1 +	120.0
00:02:00.1	TELEMETER CALIBRATE OFF	0111 1111	S-IC	1	T1 +	120.1
00:02:10.0	FLIGHT CONTROL COMPUTER SWITCH POINT NO. 2	0100 0001	IU	21	T1 +	130.0
00:02:12.4	FUEL PRESSURIZING VALVE NO. 4 OPEN	0001 1101	S-IC	7	T1 +	132.4
00:02:13.6	S-IC TWO ENGINES BUT AUTO-ABORT INHIBIT ENABLE	0000 1110	IU	51	T1 +	133.6
00:02:13.8	S-IC TWO ENGINES BUT AUTO-ABORT INHIBIT	0001 1110	IU	35	T1 +	133.8
00:02:14.4	TWO ADJACENT OUTBOARD ENGINES BUT CUTOFF ENABLE	0001 1111	S-IC	17	T1 +	134.4
00:02:14.6	INBOARD ENGINE CUTOFF	0011 1111	S-IC	8	T1 +	134.6



NOMINAL FLIGHT TIME HR MIN SEC	COMMAND	SWITCH SELECTOR			TIME FROM BASE SECONDS	
		CODE	STAGE	CHN		
00:02:14.7	START OF TIME BASE NO. 2 (T2)				T2 +	.0
00:02:14.9	INBOARD ENGINE CUTOFF BACKUP	0001 0001	SIC	16	T2 +	.2
00:02:15.1	START FIRST PAM-FM/FM CALIBRATION	0000 0011	S-II	30	T2 +	.4
00:02:15.3	AUTO-ABORT ENABLE RELAYS RESET	0001 0001	IU	16	T2 +	.6
00:02:15.5	EXCESS RATE (ROLL) AUTO-ABORT INHIBIT ENABLE	0100 1111	IU	34	T2 +	.8
00:02:15.7	EXCESS RATE (ROLL) AUTO-ABORT INHIBIT AND SWITCH RATE GYRO'S SC INDICATION 'B'	0111 0001	IU	50	T2 +	1.0
00:02:20.1	STOP FIRST PAM-FM/FM CALIBRATION	0001 0011	S-II	9	T2 +	5.4
00:02:29.2	S-II ORDNANCE ARM	0111 0011	S-II	11	T2 +	14.5
00:02:29.4	SEPARATION AND RETRO NO. 1 EBW FIRING UNITS ARM	0110 0011	S-IC	10	T2 +	14.7
00:02:29.6	SEPARATION AND RETRO NO. 2 EBW FIRING UNITS ARM	0110 1110	S-IC	20	T2 +	14.9
00:02:31.5	Q-BALL POWER OFF	0111 1111	IU	1	T2 +	16.8
00:02:31.7	OUTBOARD ENGINES CUTOFF ENABLE	0001 0011	S-IC	9	T2 +	17.0
00:02:31.9	OUTBOARD ENGINES CUTOFF BACKUP ENABLE	0000 1101	S-IC	14	T2 +	17.2

40M33627B

NOMINAL FLIGHT TIME HR MIN SEC	COMMAND	SWITCH SELECTOR			TIME FROM BASE SECONDS
		CODE	STAGE	CHN	
00:02:40.6	OUTBOARD ENGINES CUTOFF - START OF TIME BASE NO. 3 (T3)				T3 + .0
00:02:40.7	LH2 TANK HIGH PRESSURE VENT MODE	0011 0001	S-II	38	T3 + .1
00:02:40.8	S-II LH2 RECIRCULATION PUMPS OFF	0010 1100	S-II	48	T3 + .2
00:02:41.1	S-II ULLAGE TRIGGER	0001 0010	S-II	24	T3 + .5
00:02:41.3	S-IC/S-II SEPARATION (NO. 1)	0110 1111	S-IC	15	T3 + .7
00:02:41.4	S-IC/S-II SEPARATION (NO. 2)	0101 0010	S-IC	19	T3 + .8
00:02:41.5	S-II ENGINES CUTOFF RESET	0010 0011	S-II	31	T3 + .9
00:02:41.6	ENGINES READY BYPASS	0110 1110	S-II	20	T3 + 1.0
00:02:41.7	PREVALVES LOCKOUT RESET	0101 0010	S-II	19	T3 + 1.1
00:02:41.8	SWITCH ENGINE CONTROL TO S-II AND S-IC OUTBOARD ENGINES CANT OFF 'A'	0001 1100	IU	33	T3 + 1.2
00:02:41.9	S-IC OUTBOARD ENGINES CANT OFF 'B'	0101 0111	IU	86	T3 + 1.3
00:02:42.0	S-II ENGINES START	0001 1100	S-II	33	T3 + 1.4

NOMINAL FLIGHT TIME HR MIN SEC	COMMAND	SWITCH SELECTOR			TIME FROM BASE SECONDS
		CODE	STAGE	CHN	
00:02:42.1	S-II ENGINE OUT INDICATION 'A' ENABLE; S-II AFT INTERSTAGE SEPARATION INDICATION 'A' ENABLE	0111 1100	IU	28	T3 + 1.5
00:02:42.3	S-II ENGINE OUT INDICATION 'B' ENABLE; S-II AFT INTERSTAGE SEPARATION INDICATION 'B' ENABLE	0010 1100	IU	48	T3 + 1.7
00:02:42.5	ENGINES READY BYPASS RESET	0000 1100	S-II	49	T3 + 1.9
00:02:43.6	S-II HYDRAULIC ACCUMULATORS UNLOCK	0100 1101	S-II	12	T3 + 3.0
00:02:47.0	CHILLDOWN VALVES CLOSE	0101 1100	S-II	88	T3 + 6.4
00:02:47.3	S-II START PHASE LIMITER CUTOFF ARM	0011 1101	S-II	25	T3 + 6.7
00:02:47.5	HIGH (5.5)ENGINE MIXTURE RATIO ON	0110 1011	S-II	59	T3 + 6.9
00:02:48.3	S-II START PHASE LIMITER CUTOFF ARM RESET	0010 1101	S-II	6	T3 + 7.7
00:02:48.4	PREVALVES CLOSE ARM	0101 0110	S-II	99	T3 + 7.8
00:03:00.0	WATER COOLANT VALVE OPEN	0110 0101	IU	107	T3 + 19.4
00:03:11.3	S-II AFT INTERSTAGE SEPARATION	0010 0010	S-II	23	T3 + 30.7
00:03:42.0	FLIGHT CONTROL COMPUTER SWITCH POINT NO. 3	0101 0001	IU	22	T3 + 61.4
00:04:20.6	S-II LOX STEP PRESSURIZATION ON	0000 1101	S-II	14	T3 + 100.0

40M33627B

NOMINAL FLIGHT TIME HR MIN SEC	COMMAND	SWITCH SELECTOR			TIME FROM BASE SECONDS
		CODE	STAGE	CHN	
00:04:45.6	START SECOND PAM-FM/FM CALIBRATION	0000 0011	S-II	30	T3 + 125.0
00:04:50.6	STOP SECOND PAM-FM/FM CALIBRATION	0001 0011	S-II	9	T3 + 130.0
00:05:52.0	FLIGHT CONTROL COMPUTER SWITCH POINT NO. 4	0110 0001	IU	4	T3 + 191.4
00:06:03.3	TELEMETRY CALIBRATOR IN-FLIGHT CALIBRATE ON	0010 0010	IU	23	T3 + 202.7
00:06:08.3	TELEMETRY CALIBRATOR IN-FLIGHT CALIBRATE OFF	0001 0010	IU	24	T3 + 207.7
00:06:25.6	START THIRD PAM-FM/FM CALIBRATION	0000 0011	S-II	30	T3 + 225.0
00:06:30.6	STOP THIRD PAM-FM/FM CALIBRATION	0001 0011	S-II	9	T3 + 230.0
00:07:31.5	TELEMETRY CALIBRATOR IN-FLIGHT CALIBRATE ON	0010 0010	IU	23	T3 + 290.9
00:07:36.5	TELEMETRY CALIBRATOR IN-FLIGHT CALIBRATE OFF	0001 0010	IU	24	T3 + 295.9
00:07:39.6	S-II INBOARD ENGINE CUTOFF EFF 507 AND 508 ONLY	0110 1111	S-II	15	T3 + 299.0
00:07:40.6	S-II LH2 STEP PRESSURIZATION	0001 1101	S-II	7	T3 + 300.0
00:08:11.8	CHARGE ULLAGE IGNITION ON	0111 0100	S-IVB	54	T3 + 331.2
00:08:12.0	S-II/S-IVB ORDNANCE ARM	0011 1111	S-II	8	T3 + 331.4
00:08:35.6	S-II LOX DEPLETION SENSORS CUTOFF ARM	0110 0010	S-II	3	T3 + 355.0

NOMINAL FLIGHT TIME HR MIN SEC	COMMAND	SWITCH SELECTOR			TIME FROM BASE SECONDS
		CODE	STAGE	CHN	
00:08:35.8	S-II LH2 DEPLETION SENSORS CUTOFF ARM	0101 1110	S-II	42	T3 + 355.2

40M33627B

NOMINAL FLIGHT TIME HR MIN SEC	COMMAND	SWITCH SELECTOR			TIME FROM BASE SECONDS	
		CODE	STAGE	CHN		
TBD	S-II ENGINES CUTOFF - START OF TIME BASE NO. 4 (T4)				T4 +	.0
TBD	S-II ENGINES CUTOFF ON	0011 0011	S-II	18	T4 +	.1
TBD	PREVALVES CLOSE OFF	0110 1001	SIVB	83	T4 +	.2
TBD	L0X TANK PRESSURIZATION SHUTOFF VALVES OPEN	0111 1010	SIVB	80	T4 +	.3
TBD	S-IVB ENGINE CUTOFF OFF	0111 0010	SIVB	13	T4 +	.4
TBD	L0X TANK FLIGHT PRESSURE SYSTEM ON	0111 1001	SIVB	103	T4 +	.5
TBD	ENGINE READY BYPASS	0110 0011	SIVB	10	T4 +	.6
TBD	L0X CHILLDOWN PUMP OFF	0010 0010	SIVB	23	T4 +	.7
TBD	FIRE ULLAGE IGNITION ON	0101 0100	SIVB	56	T4 +	.8
TBD	S-II/S-IVB SEPARATION	0000 0010	S-II	5	T4 +	.9
TBD	S-IVB ENGINE START ON	0001 0011	SIVB	9	T4 +	1.0
TBD	FLIGHT CONTROL COMPUTER S-IVB BURN MODE ON 'A'	0010 0011	IU	31	T4 +	1.2
TBD	FLIGHT CONTROL COMPUTER S-IVB BURN MODE ON 'B'	0000 0100	IU	74	T4 +	1.4

NOMINAL FLIGHT TIME HR MIN SEC	COMMAND	SWITCH SELECTOR			TIME FROM BASE SECONDS
		CODE	STAGE	CHN	
TBD	FUEL CHILLDOWN PUMP OFF	0110 1011	SIVB	59	T4 + 2.2
TBD	S-IVB ENGINE OUT INDICATION 'A' ENABLE	0001 0011	IU	9	T4 + 2.5
TBD	S-IVB ENGINE OUT INDICATION 'B' ENABLE	0111 0011	IU	11	T4 + 2.7
TBD	FUEL INJECTION TEMPERATURE OK BYPASS	0111 0011	SIVB	11	T4 + 4.0
TBD	S-IVB ENGINE START OFF	0101 1101	SIVB	27	T4 + 4.2
TBD	FIRST BURN RELAY ON	0001 1001	SIVB	68	T4 + 5.8
TBD	CHARGE ULLAGE JETTISON ON	0110 0100	SIVB	55	T4 + 9.8
TBD	FIRE ULLAGE JETTISON ON	0001 1010	SIVB	57	T4 + 12.8
TBD	ULLAGE CHARGING RESET	0101 1100	SIVB	88	T4 + 13.8
TBD	ULLAGE FIRING RESET	0010 1011	SIVB	73	T4 + 14.0
TBD	FUEL INJECTION TEMPERATURE OK BYPASS RESET	0001 0001	SIVB	16	T4 + 14.2
TBD	TELEMETRY CALIBRATOR IN-FLIGHT CALIBRATE ON	0010 0010	IU	23	T4 + 16.8
TBD	TELEMETRY CALIBRATOR IN-FLIGHT CALIBRATE OFF	0001 0010	IU	24	T4 + 21.8
TBD	HEAT-EXCHANGER BYPASS VALVE CONTROL ENABLE	0111 0001	SIVB	50	T4 + 24.0
TBD	TM CALIBRATE ON	0100 1010	SIVB	62	T4 + 26.2





NOMINAL FLIGHT TIME HR MIN SEC	COMMAND	SWITCH SELECTOR			TIME FROM BASE SECONDS	
		CODE	STAGE	CHN		
TBD	START OF TIME BASE NO. 5 (T5)				T5 +	.0
TBD	SIVB ENGINE CUTOFF ON	0100 1101	SIVB	12	T5 +	.1
TBD	POINT LEVEL SENSOR DISARMING	0100 0100	SIVB	98	T5 +	.2
TBD	S-IVB ULLAGE ENGINE NO. 1 ON	0101 1110	SIVB	42	T5 +	.3
TBD	S-IVB ULLAGE ENGINE NO. 2 ON	0011 0110	SIVB	101	T5 +	.4
TBD	S-IVB ULLAGE THRUST PRESENT INDICATION ON	0111 1110	IU	43	T5 +	.6
TBD	FIRST BURN RELAY OFF	0010 1001	SIVB	69	T5 +	.8
TBD	L0X TANK FLIGHT PRESSURE SYSTEM OFF	0111 0111	SIVB	104	T5 +	1.2
TBD	L0X TANK PRESSURIZATION SHUTOFF VALVES CLOSE ON	0110 1010	SIVB	79	T5 +	1.4
TBD	ENGINE PUMP PURGE CONTROL VALVE ENABLE ON	0001 0010	SIVB	24	T5 +	1.6
TBD	FLIGHT CONTROL COMPUTER S-IVB BURN MODE OFF 'A'	0100 1101	IU	12	T5 +	3.5
TBD	FLIGHT CONTROL COMPUTER S-IVB BURN MODE OFF 'B'	0001 0100	IU	75	T5 +	3.7
TBD	AUX. HYDRAULIC PUMP FLIGHT MODE OFF	0011 1100	SIVB	29	T5 +	4.1
TBD	TELEMETRY CALIBRATOR IN-FLIGHT CALIBRATE ON	0010 0010	IU	23	T5 +	4.2

40M33627B

NOMINAL FLIGHT TIME HR MIN SEC	COMMAND	SWITCH SELECTOR			TIME FROM BASE SECONDS	
		CODE	STAGE	CHN		
TBD	S/C CONTROL OF SATURN ENABLE	0001 1001	IU	68	T5 +	5.0
TBD	TM CALIBRATE ON	0100 1010	SIVB	62	T5 +	7.0
TBD	TM CALIBRATE OFF	0000 0111	SIVB	63	T5 +	8.0
TBD	TELEMETRY CALIBRATOR IN-FLIGHT CALIBRATE OFF	0001 0010	IU	24	T5 +	9.2
TBD	S-IVB ENGINE OUT INDICATION 'A' ENABLE RESET	0011 0011	IU	18	T5 +	10.0
TBD	S-IVB ENGINE OUT INDICATION 'B' ENABLE RESET	0010 0001	IU	53	T5 +	10.2
TBD	REGULAR CALIBRATE RELAYS ON EFF 507 AND 508 ONLY	0100 0010	SIVB	46	T5 +	24.5
TBD	REGULAR CALIBRATE RELAYS OFF EFF 507 AND 508 ONLY	0110 1101	SIVB	47	T5 +	29.5
TBD	SINGLE SIDEBAND SYSTEM DISABLE EFF 507 AND 508 ONLY	0110 1111	SIVB	15	T5 +	30.0
TBD	LH2 TANK CONTINUOUS VENT ORIFICE SHUTOFF VALVE OPEN ON	0000 1010	SIVB	111	T5 +	59.0
TBD	LH2 TANK CONTINUOUS VENT RELIEF OVERRIDE SHUTOFF VALVE OPEN ON	0110 0101	SIVB	107	T5 +	59.1

NOMINAL FLIGHT TIME HR MIN SEC	COMMAND	SWITCH SELECTOR			TIME FROM BASE SECONDS
		CODE	STAGE	CHN	
TBD	LH2 TANK CONTINUOUS VENT ORIFICE SHUTOFF VALVE OPEN OFF	0100 1011	SIVB	112	T5 + 61.0
TBD	LH2 TANK CONTINUOUS VENT RELIEF OVERRIDE SHUTOFF VALVE OPEN OFF	0100 0101	SIVB	108	T5 + 61.1
TBD	S-IVB ULLAGE ENGINE NO. 1 OFF	0111 1110	SIVB	43	T5 + 87.0
TBD	S-IVB ULLAGE ENGINE NO. 2 OFF	0010 0110	SIVB	102	T5 + 87.1
TBD	S-IVB ULLAGE THRUST PRESENT INDICATION OFF	0100 0010	IU	46	T5 + 87.2
TBD	P. U. INVERTER AND D.C. POWER OFF	0011 1111	SIVB	8	T5 + 500.0
TBD	ENGINE PUMP PURGE CONTROL VALVE ENABLE OFF	0011 1101	SIVB	25	T5 + 602.6
TBD	AUX. HYDRAULIC PUMP FLIGHT MODE ON	0111 1100	SIVB	28	T5 + 2600.0
TBD	AUX. HYDRAULIC PUMP FLIGHT MODE OFF	0011 1100	SIVB	29	T5 + 2648.0
TBD	PU INVERTER AND D.C. POWER ON	0001 1101	SIVB	7	T5 + 5000.0
TBD	AUX. HYDRAULIC PUMP FLIGHT MODE ON	0111 1100	SIVB	28	T5 + 5400.0
TBD	AUX. HYDRAULIC PUMP FLIGHT MODE OFF	0011 1100	SIVB	29	T5 + 5448.0
TBD	AUX. HYDRAULIC PUMP FLIGHT MODE ON	0111 1100	SIVB	28	T5 + 10500.0

40M33627B

NOMINAL FLIGHT TIME HR MIN SEC	COMMAND	SWITCH SELECTOR			TIME FROM BASE SECONDS
		CODE	STAGE	CHN	
TBD	AUX. HYDRAULIC PUMP FLIGHT MODE OFF	0011 1100	SIVB	29	T5 + 10980.0

NOMINAL FLIGHT TIME HR MIN SEC	COMMAND	SWITCH SELECTOR			TIME FROM BASE SECONDS	
		CODE	STAGE	CHN		
TBD	BEGIN RESTART PREPARATIONS-START OF TIME BASE NO. 6 (T6)				T6 +	.0
TBD	S-IVB RESTART ALERT ON	0111 1010	IU	80	T6 +	.1
TBD	S/C CONTROL OF SATURN DISABLE	0010 1001	IU	69	T6 +	.3
TBD	AMBIENT HE SUPPLY SHUTOFF VALVE CLOSED OFF	0100 0001	SIVB	21	T6 +	.7
TBD	TELEMETRY CALIBRATOR IN-FLIGHT CALIBRATE ON	0010 0010	IU	23	T6 +	1.2
TBD	TM CALIBRATE ON	0100 1010	SIVB	62	T6 +	1.4
TBD	TM CALIBRATE OFF	0000 0111	SIVB	63	T6 +	2.4
TBD	TELEMETRY CALIBRATOR IN-FLIGHT CALIBRATE OFF	0001 0010	IU	24	T6 +	6.2
TBD	LH2 TANK VENT AND LATCHING RELIEF VALVES BOOST CLOSE ON	0110 0110	SIVB	77	T6 +	36.3
TBD	L0X TANK VENT AND NPV VALVES BOOST CLOSE ON	0011 1011	SIVB	95	T6 +	36.5
TBD	S-IVB RESTART ALERT OFF	0000 0101	IU	81	T6 +	37.3
TBD	LH2 TANK VENT AND LATCHING RELIEF VALVES BOOST CLOSE OFF	0111 0110	SIVB	78	T6 +	38.3

40M33627B

NOMINAL FLIGHT TIME HR MIN SEC	COMMAND	SWITCH SELECTOR			TIME FROM BASE SECONDS
		CODE	STAGE	CHN	
TBD	L <sub>0</sub> X TANK VENT AND NPV VALVES BOOST CLOSE OFF	0001 1011	SIVB	96	T6 + 38.5
TBD	AMBIENT REPRESS. SYSTEM MODE SELECTOR OFF AND CRYO ON	0000 0001	SIVB	37	T6 + 41.1
TBD	BURNER LH2 PROPELLANT VALVE OPEN ON (SEE NOTE 3)	0111 1101	SIVB	26	T6 + 41.3
TBD	BURNER EXCITERS ON (SEE NOTE 3)	0110 1100	SIVB	70	T6 + 41.6
TBD	BURNER L <sub>0</sub> X SHUTDOWN VALVE OPEN ON (SEE NOTE 3)	0100 0111	SIVB	89	T6 + 42.0
TBD	LH2 TANK CONTINUOUS VENT VALVE CLOSE ON (SEE NOTE 3)	0101 1001	SIVB	84	T6 + 42.2
TBD	BURNER LH2 PROPELLANT VALVE OPEN OFF (SEE NOTE 3)	0111 1011	SIVB	72	T6 + 42.8
TBD	BURNER L <sub>0</sub> X SHUTDOWN VALVE OPEN OFF (SEE NOTE 3)	0010 0111	SIVB	90	T6 + 43.5
TBD	LH2 TANK CONTINUOUS VENT VALVE CLOSE OFF (SEE NOTE 3)	0000 1001	SIVB	87	T6 + 44.2
TBD	SECOND BURN RELAY ON	0100 0011	SIVB	32	T6 + 45.2
TBD	BURNER EXCITERS OFF (SEE NOTE 3)	0001 0111	SIVB	71	T6 + 45.4
TBD	BURNER AUTOMATIC CUTOFF SYSTEM ARM (SEE NOTE 3)	0110 0111	SIVB	85	T6 + 48.0

NOMINAL FLIGHT TIME HR MIN SEC	COMMAND	SWITCH SELECTOR			TIME FROM BASE SECONDS
		CODE	STAGE	CHN	
TBD	LH2 TANK REPRESSURIZATION CONTROL VALVE OPEN ON (SEE NOTE 3)	0000 1111	SIVB	39	T6 + 48.1
TBD	L0X TANK REPRESSURIZATION CONTROL VALVE OPEN ON (SEE NOTE 3)	0110 0010	SIVB	3	T6 + 48.3
TBD	AUX. HYDRAULIC PUMP FLIGHT MODE ON	0111 1100	SIVB	28	T6 + 219.0
TBD	L0X CHILLDOWN PUMP ON	0101 0001	SIVB	22	T6 + 249.0
TBD	FUEL CHILLDOWN PUMP ON	0011 1001	SIVB	58	T6 + 254.0
TBD	PREVALVES CLOSE ON	0001 0110	SIVB	82	T6 + 259.0
TBD	TELEMETRY CALIBRATOR IN-FLIGHT CALIBRATE ON	0010 0010	IU	23	T6 + 400.2
TBD	TM CALIBRATE ON	0100 1010	SIVB	62	T6 + 400.4
TBD	TM CALIBRATE OFF	0000 0111	SIVB	63	T6 + 401.4
TBD	TELEMETRY CALIBRATOR IN-FLIGHT CALIBRATE OFF	0001 0010	IU	24	T6 + 405.2
TBD	P. U. MIXTURE RATIO 4.5 ON	0001 1111	SIVB	17	T6 + 450.1
TBD	S-IVB RESTART ALERT ON	0111 1010	IU	80	T6 + 493.6
TBD	S-IVB ULLAGE ENGINE NO. 1 ON	0101 1110	SIVB	42	T6 + 496.3

40M33627B

NOMINAL FLIGHT TIME HR MIN SEC	COMMAND	SWITCH SELECTOR			TIME FROM BASE SECONDS
		CODE	STAGE	CHN	
TBD	S-IVB ULLAGE ENGINE NO. 2 ON	0011 0110	SIVB	101	T6 + 496.4
TBD	S-IVB ULLAGE THRUST PRESENT INDICATION ON	0111 1110	IU	43	T6 + 496.5
TBD	L0X TANK REPRESSURIZATION CONTROL VALVE OPEN OFF (SEE NOTE 3)	0110 0001	SIVB	4	T6 + 496.6
TBD	LH2 TANK REPRESSURIZATION CONTROL VALVE OPEN OFF (SEE NOTE 3)	0000 0101	SIVB	81	T6 + 496.7
TBD	BURNER LH2 PROPELLANT VALVE CLOSE ON (SEE NOTE 3)	0101 1011	SIVB	60	T6 + 496.8
TBD	BURNER AUTOMATIC CUTOFF SYSTEM DISARM (SEE NOTE 3)	0101 0111	SIVB	86	T6 + 497.0
TBD	LH2 TANK CONTINUOUS VENT VALVE CLOSE ON	0101 1001	SIVB	84	T6 + 497.2
TBD	AMBIENT REPRESS. SYSTEM MODE SELECTOR ON AND CRYO OFF	0011 1110	SIVB	36	T6 + 497.6
TBD	LH2 TANK CONTINUOUS VENT VALVE CLOSE OFF	0000 1001	SIVB	87	T6 + 499.2
TBD	BURNER LH2 PROPELLANT VALVE CLOSE OFF (SEE NOTE 3)	0010 0100	SIVB	61	T6 + 499.8



NOMINAL FLIGHT TIME HR MIN SEC	COMMAND	SWITCH SELECTOR			TIME FROM BASE SECONDS
		CODE	STAGE	CHN	
TBD	L0X TANK REPRESSURIZATION CONTROL VALVE OPEN ON	0110 0010	SIVB	3	T6 + 500.0
TBD	BURNER L0X SHUTDOWN VALVE CLOSE ON (SEE NOTE 3)	0000 0100	SIVB	74	T6 + 501.3
TBD	BURNER L0X SHUTDOWN VALVE CLOSE OFF (SEE NOTE 3)	0001 0100	SIVB	75	T6 + 504.3
TBD	LH2 TANK REPRESSURIZATION CONTROL VALVE OPEN ON	0000 1111	SIVB	39	T6 + 520.0
TBD	S-IVB ENGINE CUTOFF OFF	0111 0010	SIVB	13	T6 + 540.0
TBD	PREVALVES CLOSE OFF	0110 1001	SIVB	83	T6 + 559.4
TBD	S-IVB RESTART ALERT OFF	0000 0101	IU	81	T6 + 560.0
TBD	ENGINE READY BYPASS	0110 0011	SIVB	10	T6 + 568.6
TBD	FUEL CHILLDOWN PUMP OFF	0110 1011	SIVB	59	T6 + 569.4
TBD	L0X CHILLDOWN PUMP OFF	0010 0010	SIVB	23	T6 + 569.6
TBD	S-IVB ENGINE START ON	0001 0011	SIVB	9	T6 + 570.0
TBD	S-IVB ULLAGE ENGINE NO. 1 OFF	0111 1110	SIVB	43	T6 + 573.0
TBD	S-IVB ULLAGE ENGINE NO. 2 OFF	0010 0110	SIVB	102	T6 + 573.1
TBD	S-IVB ULLAGE THRUST PRESENT INDICATION OFF	0100 0010	IU	46	T6 + 573.2
TBD	S-IVB ENGINE OUT INDICATION 'A' ENABLE	0001 0011	IU	9	T6 + 576.8

40M33627B

NOMINAL FLIGHT TIME HR MIN SEC	COMMAND	SWITCH SELECTOR			TIME FROM BASE SECONDS	
		CODE	STAGE	CHN		
TBD	S-IVB ENGINE OUT INDICATION 'B' ENABLE	0111 0011	IU	11	T6 +	577.0
TBD	L0X TANK REPRESSURIZATION CONTROL VALVE OPEN OFF	0110 0001	SIVB	4	T6 +	577.2
TBD	LH2 TANK REPRESSURIZATION CONTROL VALVE OPEN OFF	0000 0101	SIVB	81	T6 +	577.4
TBD	FLIGHT CONTROL COMPUTER S-IVB BURN MODE ON 'A'	0010 0011	IU	31	T6 +	577.6
TBD	FLIGHT CONTROL COMPUTER S-IVB BURN MODE ON 'B'	0000 0100	IU	74	T6 +	577.8
TBD	FUEL INJECTION TEMPERATURE OK BYPASS	0111 0011	SIVB	11	T6 +	578.0
TBD	L0X TANK FLIGHT PRESSURE SYSTEM ON	0111 1001	SIVB	103	T6 +	578.2
TBD	L0X TANK PRESSURIZATION SHUTOFF VALVES OPEN ON	0111 1010	SIVB	80	T6 +	578.4
TBD	S-IVB ENGINE START OFF	0101 1101	SIVB	27	T6 +	578.6
TBD	P. U. PROGRAMMED MIXTURE RATIO OFF (SEE NOTE *)	0011 0011	SIVB	18	T6 +	583.5
TBD	FUEL INJECTION TEMPERATURE OK BYPASS RESET	0001 0001	SIVB	16	T6 +	588.0
TBD	P. U. PROGRAMMED MIXTURE RATIO OFF	0011 0011	SIVB	18	T6 +	680.5
TBD	FLIGHT CONTROL COMPUTER SWITCH POINT NO. 6	0000 0010	IU	5	T6 +	838.0
TBD	SECOND BURN RELAY OFF	0001 1100	SIVB	33	T6 +	850.0
TBD	POINT LEVEL SENSOR ARMING (SEE NOTE*)	0000 0110	SIVB	97	T6 +	885.0

NOMINAL FLIGHT TIME HR MIN SEC	COMMAND	SWITCH SELECTOR			TIME
		CODE	STAGE	CHN	FROM BASE SECONDS
TBD	POINT LEVEL SENSOR ARMING	0000 0110	SIVB	97	T6 + 900.0
TBD	VELOCITY OR S/C INITATED-SIVB ENGINE CUTOFF ON	0100 1101	SIVB	12	T7 - 0.2
	NOTE*				
	INHIBITED FOR FIRST OPPORTUNITY RESTART. THE				
	LVDC WILL ISSUE THIS COMMAND ON SECOND OPPORT-				
	UNITY RESTART ONLY.				

40M33627B

NOMINAL FLIGHT TIME HR MIN SEC	COMMAND	SWITCH SELECTOR			TIME FROM BASE SECONDS	
		CODE	STAGE	CHN		
TBD	START OF TIME BASE NO. 7 (T7)				T7 +	0.0
TBD	S-IVB ENGINE CUTOFF ON	0100 1101	SIVB	12	T7 +	0.1
TBD	LH2 TANK CONTINUOUS VENT ORIFICE SHUTOFF VALVE OPEN ON	0000 1010	SIVB	111	T7 +	0.5
TBD	LH2 TANK CONTINUOUS VENT RELIEF OVERRIDE SHUTOFF VALVE OPEN ON	0110 0101	SIVB	107	T7 +	0.6
TBD	L0X TANK NPV VALVE OPEN ON	0100 1100	SIVB	105	T7 +	0.7
TBD	LH2 TANK LATCHING RELIEF VALVE OPEN ON	0101 0110	SIVB	99	T7 +	0.8
TBD	L0X TANK PRESSURIZATION SHUTOFF VALVES CLOSE ON	0110 1010	SIVB	79	T7 +	1.0
TBD	L0X TANK FLIGHT PRESSURE SYSTEM OFF	0111 0111	SIVB	104	T7 +	1.1
TBD	SECOND BURN RELAY OFF	0001 1100	SIVB	33	T7 +	1.2
TBD	LH2 TANK REPRESSURIZATION CONTROL VALVE OPEN ON	0000 1111	SIVB	39	T7 +	1.3
TBD	P. U. PROGRAMMED MIXTURE RATIO OFF	0011 0011	SIVB	18	T7 +	1.5
TBD	POINT LEVEL SENSOR DISARMING	0100 0100	SIVB	98	T7 +	1.7

NOMINAL FLIGHT TIME HR MIN SEC	COMMAND	SWITCH SELECTOR			TIME FROM BASE SECONDS	
		CODE	STAGE	CHN		
TBD	START TANK VENT CONTROL VALVE OPEN ON	0111 1111	SIVB	1	T7 +	2.0
TBD	LH2 TANK CONTINUOUS VENT ORIFICE SHUTOFF VALVE OPEN OFF	0100 1011	SIVB	112	T7 +	2.5
TBD	LH2 TANK CONTINUOUS VENT RELIEF OVERRIDE SHUTOFF VALVE OPEN OFF	0100 0101	SIVB	108	T7 +	2.6
TBD	LH2 TANK LATCHING RELIEF VALVE LATCH ON	0010 1110	SIVB	52	T7 +	2.8
TBD	FLIGHT CONTROL COMPUTER S-IVB BURN MODE OFF 'A'	0100 1101	IU	12	T7 +	3.6
TBD	FLIGHT CONTROL COMPUTER S-IVB BURN MODE OFF 'B'	0001 0100	IU	75	T7 +	3.8
TBD	LH2 TANK LATCHING RELIEF VALVE OPEN OFF	0101 1010	SIVB	100	T7 +	4.0
TBD	AUX. HYDRAULIC PUMP FLIGHT MODE OFF	0011 1100	SIVB	29	T7 +	4.2
TBD	S/C CONTROL OF SATURN ENABLE	0001 1001	IU	68	T7 +	5.0
TBD	LH2 TANK LATCHING RELIEF VALVE LATCH OFF	0101 0010	SIVB	19	T7 +	5.2
TBD	S-IVB ENGINE OUT INDICATION 'A' ENABLE RESET	0011 0011	IU	18	T7 +	10.0
TBD	S-IVB ENGINE OUT INDICATION 'B' ENABLE RESET	0010 0001	IU	53	T7 +	10.2
TBD	AMBIENT REPRESS. SYSTEM MODE SELECTOR OFF AND CRYO ON	0000 0001	SIVB	37	T7 +	61.0

40M33627B

NOMINAL FLIGHT TIME HR MIN SEC	COMMAND	SWITCH SELECTOR			TIME FROM BASE SECONDS
		CODE	STAGE	CHN	
TBD	L0X TANK NPV VALVE OPEN OFF	0111 0101	SIVB	106	T7 + 150.7
TBD	START TANK VENT CONTROL VALVE OPEN OFF	0101 1111	SIVB	2	T7 + 152.0
TBD	L0X TANK VENT AND NPV VALVES BOOST CLOSE ON	0011 1011	SIVB	95	T7 + 153.7
TBD	L0X TANK VENT AND NPV VALVES BOOST CLOSE OFF	0001 1011	SIVB	96	T7 + 155.7
TBD	LH2 TANK LATCHING RELIEF VALVE OPEN ON	0101 0110	SIVB	99	T7 + 899.0
TBD	LH2 TANK REPRESSURIZATION CONTROL VALVE OPEN OFF	0000 0101	SIVB	81	T7 + 899.6
TBD	LH2 TANK CONTINUOUS VENT VALVE CLOSE ON	0101 1001	SIVB	84	T7 + 899.8
TBD	LH2 TANK LATCHING RELIEF VALVE OPEN OFF	0101 1010	SIVB	100	T7 + 900.0
TBD	LH2 TANK CONTINUOUS VENT VALVE CLOSE OFF	0000 1001	SIVB	87	T7 + 901.8
TBD	LH2 TANK VENT AND LATCHING RELIEF VALVES BOOST CLOSE ON	0110 0110	SIVB	77	T7 + 903.0
TBD	LH2 TANK VENT AND LATCHING RELIEF VALVES BOOST CLOSE OFF	0111 0110	SIVB	78	T7 + 905.0
TBD	IU COMMAND SYSTEM ENABLE	0001 0110	IU	82	T7 + 1200.4
TBD	AUX. HYDRAULIC PUMP FLIGHT MODE ON	0111 1100	SIVB	28	T7 + 3200.0

NOMINAL FLIGHT TIME HR MIN SEC	COMMAND	SWITCH SELECTOR			TIME FROM BASE SECONDS
		CODE	STAGE	CHN	
TBD	AUX. HYDRAULIC PUMP FLIGHT MODE OFF	0011 1100	SIVB	29	T7 + 3248.0
TBD	LH2 TANK LATCHING RELIEF VALVE OPEN ON	0101 0110	SIVB	99	T7 + 3600.4
TBD	LH2 TANK REPRESSURIZATION CONTROL VALVE OPEN ON	0000 1111	SIVB	39	T7 + 3600.6
TBD	LH2 TANK LATCHING RELIEF VALVE LATCH ON	0010 1110	SIVB	52	T7 + 3602.4
TBD	LH2 TANK LATCHING RELIEF VALVE OPEN OFF	0101 1010	SIVB	100	T7 + 3603.4
TBD	LH2 TANK LATCHING RELIEF VALVE LATCH OFF	0101 0010	SIVB	19	T7 + 3604.4
TBD	LH2 TANK LATCHING RELIEF VALVE OPEN ON	0101 0110	SIVB	99	T7 + 4499.0
TBD	LH2 TANK REPRESSURIZATION CONTROL VALVE OPEN OFF	0000 0101	SIVB	81	T7 + 4499.2
TBD	LH2 TANK LATCHING RELIEF VALVE OPEN OFF	0101 1010	SIVB	100	T7 + 4500.0
TBD	LH2 TANK VENT AND LATCHING RELIEF VALVES BOOST CLOSE ON	0110 0110	SIVB	77	T7 + 4503.0
TBD	LH2 TANK VENT AND LATCHING RELIEF VALVES BOOST CLOSE OFF	0111 0110	SIVB	78	T7 + 4505.0

40M33627B

NOMINAL FLIGHT TIME HR MIN SEC	COMMAND	SWITCH SELECTOR			TIME FROM BASE SECONDS	
		CODE	STAGE	CHN		
VARIABLE	START OF TIME BASE NO. 8 (T8)				T8 +	0.0
VARIABLE	S-IVB ENGINE EDS CUTOFF NO. 2 DISABLE	0010 0001	SIVB	53	T8 +	0.2
VARIABLE	LH2 TANK CONTINUOUS VENT ORIFICE SHUTOFF VALVE OPEN ON	0000 1010	SIVB	111	T8 +	0.4
VARIABLE	LH2 TANK CONTINUOUS VENT RELIEF OVERRIDE SHUTOFF VALVE OPEN ON	0110 0101	SIVB	107	T8 +	0.6
VARIABLE	ENGINE PUMP PURGE CONTROL VALVE ENABLE ON	0001 0010	SIVB	24	T8 +	0.8
VARIABLE	LH2 TANK REPRESSURIZATION CONTROL VALVE OPEN ON	0000 1111	SIVB	39	T8 +	1.0
VARIABLE	LH2 TANK CONTINUOUS VENT ORIFICE SHUTOFF VALVE OPEN OFF	0100 1011	SIVB	112	T8 +	2.4
VARIABLE	LH2 TANK CONTINUOUS VENT RELIEF OVERRIDE SHUTOFF VALVE OPEN OFF	0100 0101	SIVB	108	T8 +	2.6
VARIABLE	AUX. HYDRAULIC PUMP FLIGHT MODE ON	0111 1100	SIVB	28	T8 +	690.0
VARIABLE	PASSIVATION ENABLE	0010 1111	SIVB	40	T8 +	710.0



NOMINAL FLIGHT TIME HR MIN SEC	COMMAND	SWITCH SELECTOR			TIME FROM BASE SECONDS
		CODE	STAGE	CHN	
VARIABLE	ENGINE MAINSTAGE CONTROL VALVE OPEN ON	0000 0011	SIVB	30	T8 + 720.0
VARIABLE	ENGINE HE CONTROL VALVE OPEN ON	0001 0101	SIVB	109	T8 + 720.2
VARIABLE	ENGINE MAINSTAGE CONTROL VALVE OPEN OFF	0010 0011	SIVB	31	T8 + 809.0
VARIABLE	ENGINE HE CONTROL VALVE OPEN OFF	0011 0100	SIVB	110	T8 + 809.2
VARIABLE	L0X TANK NPV VALVE OPEN ON	0100 1100	SIVB	105	T8 + 1023.2
VARIABLE	L0X TANK NPV VALVE LATCH OPEN ON	0011 0010	SIVB	44	T8 + 1025.2
VARIABLE	L0X TANK NPV VALVE OPEN OFF	0111 0101	SIVB	106	T8 + 1026.2
VARIABLE	L0X TANK NPV VALVE LATCH OPEN OFF	0101 0011	SIVB	45	T8 + 1027.2
VARIABLE	ENGINE HE CONTROL VALVE OPEN ON	0001 0101	SIVB	109	T8 + 1029.4
VARIABLE	LH2 TANK REPRESSURIZATION CONTROL VALVE OPEN OFF	0000 0101	SIVB	81	T8 + 1800.5
VARIABLE	LH2 TANK LATCHING RELIEF VALVE OPEN ON	0101 0110	SIVB	99	T8 + 2031.0
VARIABLE	AUX. HYDRAULIC PUMP FLIGHT MODE OFF	0011 1100	SIVB	29	T8 + 2032.2
VARIABLE	LH2 TANK LATCHING RELIEF VALVE LATCH ON	0010 1110	SIVB	52	T8 + 2033.0
VARIABLE	LH2 TANK LATCHING RELIEF VALVE OPEN OFF	0101 1010	SIVB	100	T8 + 2034.0
VARIABLE	LH2 TANK LATCHING RELIEF VALVE LATCH OFF	0101 0010	SIVB	19	T8 + 2035.0

40M33627B

NOMINAL FLIGHT TIME HR MIN SEC	COMMAND	SWITCH SELECTOR			TIME FROM BASE SECONDS
		CODE	STAGE	CHN	
VARIABLE	ENGINE HE CONTROL VALVE OPEN OFF	0011 0100	SIVB	110	T8 + 2330.0
VARIABLE	PASSIVATION DISABLE	0100 1110	SIVB	41	T8 + 2330.2
VARIABLE	S-IVB ULLAGE ENGINE NO. 1 ON	0101 1110	SIVB	42	T8 + 2800.0
VARIABLE	S-IVB ULLAGE ENGINE NO. 2 ON	0011 0110	SIVB	101	T8 + 2800.2
VARIABLE	S-IVB ULLAGE ENGINE NO. 1 OFF	0111 1110	SIVB	43	T8 + 3240.0
VARIABLE	S-IVB ULLAGE ENGINE NO. 2 OFF	0010 0110	SIVB	102	T8 + 3240.2
VARIABLE	ENGINE PUMP PURGE CONTROL VALVE ENABLE OFF	0011 1101	SIVB	25	T8 + 3600.4

NOMINAL FLIGHT TIME HR MIN SEC	COMMAND	SWITCH SELECTOR			TIME FROM BASE SECONDS	
		CODE	STAGE	CHN		
VARIABLE	ALTERNATE SEQUENCE - START OF TIME BASE NO. 4A (T4A)				T4A +	0.0
VARIABLE	S-II ENGINES CUTOFF ON	0011 0011	S-II	18	T4A +	0.1
VARIABLE	CHARGE ULLAGE IGNITION ON	0111 0100	SIVB	54	T4A +	0.2
VARIABLE	S-II/S-IVB ORDNANCE ARM	0011 1111	S-II	8	T4A +	0.3
VARIABLE	S-IVB ENGINE CUTOFF OFF	0111 0010	SIVB	13	T4A +	0.5
VARIABLE	ENGINE READY BYPASS	0110 0011	SIVB	10	T4A +	0.6
VARIABLE	L0X TANK PRESSURIZATION SHUTOFF VALVES OPEN	0111 1010	SIVB	80	T4A +	0.9
VARIABLE	PREVALVES CLOSE OFF	0110 1001	SIVB	83	T4A +	1.4
VARIABLE	FIRE ULLAGE IGNITION ON	0101 0100	SIVB	56	T4A +	1.7
VARIABLE	S-II/S-IVB SEPARATION	0000 0010	S-II	5	T4A +	1.8
VARIABLE	L0X TANK FLIGHT PRESSURE SYSTEM ON	0111 1001	SIVB	103	T4A +	5.0
VARIABLE	L0X CHILLDOWN PUMP OFF	0010 0010	SIVB	23	T4A +	5.2
VARIABLE	S-IVB ENGINE START ON	0001 0011	SIVB	9	T4A +	5.8

40M33627B

NOMINAL FLIGHT TIME HR MIN SEC	COMMAND	SWITCH SELECTOR			TIME FROM BASE SECONDS
		CODE	STAGE	CHN	
VARIABLE	FLIGHT CONTROL COMPUTER S-IVB BURN MODE ON 'A'	0010 0011	IU	31	T4A + 6.0
VARIABLE	FLIGHT CONTROL COMPUTER S-IVB BURN MODE ON 'B'	0000 0100	IU	74	T4A + 6.2
VARIABLE	S-IVB ENGINE OUT INDICATION 'A' ENABLE	0001 0011	IU	9	T4A + 6.5
VARIABLE	S-IVB ENGINE OUT INDICATION 'B' ENABLE	0111 0011	IU	11	T4A + 6.7
VARIABLE	FUEL CHILLDOWN PUMP OFF	0110 1011	SIVB	59	T4A + 6.9
VARIABLE	FUEL INJECTION TEMPERATURE BK BYPASS	0111 0011	SIVB	11	T4A + 8.8
VARIABLE	S-IVB ENGINE START OFF	0101 1101	SIVB	27	T4A + 10.3
VARIABLE	FIRST BURN RELAY ON	0001 1001	SIVB	68	T4A + 10.5
VARIABLE	CHARGE ULLAGE JETTISON ON	0110 0100	SIVB	55	T4A + 10.8
VARIABLE	FIRE ULLAGE JETTISON ON	0001 1010	SIVB	57	T4A + 13.9
VARIABLE	ULLAGE CHARGING RESET	0101 1100	SIVB	88	T4A + 17.1
VARIABLE	ULLAGE FIRING RESET	0010 1011	SIVB	73	T4A + 17.3
VARIABLE	FUEL INJECTION TEMPERATURE BK BYPASS RESET	0001 0001	SIVB	16	T4A + 18.7
VARIABLE	WATER COBLANT VALVE OPEN	0110 0101	IU	107	T4A + 19.2
VARIABLE	TELEMETRY CALIBRATOR IN-FLIGHT CALIBRATE ON	0010 0010	IU	23	T4A + 23.2

NOMINAL FLIGHT TIME HR MIN SEC	COMMAND	SWITCH SELECTOR			TIME FROM BASE SECONDS
		CODE	STAGE	CHN	
VARIABLE	TM CALIBRATE ON	0100 1010	SIVB	62	T4A + 23.4
VARIABLE	TM CALIBRATE OFF	0000 0111	SIVB	63	T4A + 24.4
VARIABLE	TELEMETRY CALIBRATOR IN-FLIGHT CALIBRATE OFF	0001 0010	IU	24	T4A + 28.2
VARIABLE	HEAT EXCHANGER BYPASS VALVE CONTROL ENABLE	0111 0001	SIVB	50	T4A + 28.7
VARIABLE	TELEMETRY CALIBRATOR IN-FLIGHT CALIBRATE ON	0010 0010	IU	23	T4A + 200.0
VARIABLE	TM CALIBRATE ON	0100 1010	SIVB	62	T4A + 200.2
VARIABLE	TM CALIBRATE OFF	0000 0111	SIVB	63	T4A + 201.2
VARIABLE	TELEMETRY CALIBRATOR IN-FLIGHT CALIBRATE OFF	0001 0010	IU	24	T4A + 205.0
VARIABLE	FIRST BURN RELAY OFF	0010 1001	SIVB	69	T4A + 305.7
VARIABLE	FLIGHT CONTROL COMPUTER SWITCH POINT NO. 6	0000 0010	IU	5	T4A + 408.7
VARIABLE	POINT LEVEL SENSOR ARMING	0000 0110	SIVB	97	T4A + 470.0
VARIABLE	ENGINE PUMP PURGE CONTROL VALVE ENABLE ON	0001 0010	SIVB	24	C.0. = 9.0
VARIABLE	RETURN TO PRIMARY TIME BASE NO. 5 (T5) - S-IVB ENGINE CUTOFF	0100 1101	SIVB	12	T5 + 0.0

40M33627B

NOMINAL FLIGHT TIME HR MIN SEC	COMMAND	SWITCH SELECTOR			TIME FROM BASE SECONDS
		CODE	STAGE	CHN	
VARIABLE	O2-H2 BURNER MALFUNCTION - START OF TIME BASE NO. 6A (T6A)				T6A + 0.0
VARIABLE	LH2 TANK CONTINUOUS VENT ORIFICE SHUTOFF VALVE OPEN ON	0000 1010	SIVB	111	T6A + 0.2
VARIABLE	LH2 TANK CONTINUOUS VENT RELIEF OVERRIDE SHUTOFF VALVE OPEN ON	0110 0101	SIVB	107	T6A + 0.4
VARIABLE	LH2 TANK CONTINUOUS VENT ORIFICE SHUTOFF VALVE OPEN OFF	0100 1011	SIVB	112	T6A + 2.2
VARIABLE	LH2 TANK CONTINUOUS VENT RELIEF OVERRIDE SHUTOFF VALVE OPEN OFF	0100 0101	SIVB	108	T6A + 2.4

NOMINAL FLIGHT TIME HR MIN SEC	COMMAND	SWITCH SELECTOR			TIME FROM BASE SECONDS	
		CODE	STAGE	CHN		
VARIABLE	02-H2 BURNER MALFUNCTION - START OF TIME BASE NO. 6B (T6B)				T6B +	0.0
VARIABLE	S-IVB ULLAGE ENGINE NO. 1 ON	0101 1110	SIVB	42	T6B +	0.2
VARIABLE	S-IVB ULLAGE ENGINE NO. 2 ON	0011 0110	SIVB	101	T6B +	0.3
VARIABLE	S-IVB ULLAGE THRUST PRESENT INDICATION ON	0111 1110	IU	43	T6B +	0.5

40M33627B

NOMINAL FLIGHT TIME HR MIN SEC	COMMAND	SWITCH SELECTOR			TIME FROM BASE SECONDS	
		CODE	STAGE	CHN		
VARIABLE	TRANSLUNAR INJECTION INHIBIT - START OF TIME BASE NO. 6C (T6C)				T6C +	0.0
VARIABLE	L0X TANK REPRESSURIZATION CONTROL VALVE OPEN OFF	0110 0001	SIVB	4	T6C +	0.1
VARIABLE	LH2 TANK REPRESSURIZATION CONTROL VALVE OPEN OFF	0000 0101	SIVB	81	T6C +	0.2
VARIABLE	S-IVB RESTART ALERT OFF	0000 0101	IU	81	T6C +	0.4
VARIABLE	LH2 TANK CONTINUOUS VENT VALVE CLOSE OFF	0000 1001	SIVB	87	T6C +	0.6
VARIABLE	FUEL CHILLDOWN PUMP OFF	0110 1011	SIVB	59	T6C +	0.8
VARIABLE	L0X CHILLDOWN PUMP OFF	0010 0010	SIVB	23	T6C +	1.0
VARIABLE	PREVALVES CLOSE OFF	0110 1001	SIVB	83	T6C +	1.2
VARIABLE	AUX. HYDRAULIC PUMP FLIGHT MODE OFF	0011 1100	SIVB	29	T6C +	1.4
VARIABLE	LH2 TANK CONTINUOUS VENT ORIFICE SHUTOFF VALVE OPEN ON	0000 1010	SIVB	111	T6C +	1.6
VARIABLE	LH2 TANK CONTINUOUS VENT RELIEF OVERRIDE SHUTOFF VALVE OPEN ON	0110 0101	SIVB	107	T6C +	1.7



NOMINAL FLIGHT TIME HR MIN SEC	COMMAND	SWITCH SELECTOR			TIME FROM BASE SECONDS
		CODE	STAGE	CHN	
VARIABLE	S-IVB ULLAGE ENGINE NO. 1 OFF	0111 1110	SIVB	43	T6C + 1.8
VARIABLE	S-IVB ULLAGE ENGINE NO. 2 OFF	0010 0110	SIVB	102	T6C + 1.9
VARIABLE	S-IVB ULLAGE THRUST PRESENT INDICATION OFF	0100 0010	IU	46	T6C + 2.0
VARIABLE	BURNER LH2 PROPELLANT VALVE CLOSE OFF	0010 0100	SIVB	61	T6C + 2.4
VARIABLE	BURNER LOX SHUTDOWN VALVE CLOSE ON	0000 0100	SIVB	74	T6C + 2.6
VARIABLE	S/C CONTROL OF SATURN ENABLE	0001 1001	IU	68	T6C + 3.3
VARIABLE	LH2 TANK CONTINUOUS VENT ORIFICE SHUTOFF VALVE OPEN OFF	0100 1011	SIVB	112	T6C + 3.6
VARIABLE	LH2 TANK CONTINUOUS VENT RELIEF OVERRIDE SHUTOFF VALVE OPEN OFF	0100 0101	SIVB	108	T6C + 3.7
VARIABLE	BURNER LOX SHUTDOWN VALVE CLOSE OFF	0001 0100	SIVB	75	T6C + 5.6

40M33627B

NOMINAL FLIGHT TIME HR MIN SEC	COMMAND	SWITCH SELECTOR			TIME FROM BASE SECONDS
		CODE	STAGE	CHN	
	SPECIAL SEQUENCE FOR S-II P.O. SYSTEM MIXTURE RATIO SHIFT (SEE PARA. II N. SUBPARA. b.)				NOMINAL
	HIGH (5.5) ENGINE MIXTURE RATIO OFF	0011 1001	S-II	58	T3 + 319.6
	LOW (4.5) ENGINE MIXTURE RATIO ON	0101 0100	S-II	56	T3 + 319.8
	WATER COOLANT VALVE SWITCHING				
VARIABLE	WATER COOLANT VALVE OPEN	0110 0101	IU	107	VARIABLE
VARIABLE	WATER COOLANT VALVE CLOSED	0100 0101	IU	108	VARIABLE

NOMINAL FLIGHT TIME HR MIN SEC	COMMAND	SWITCH SELECTOR			TIME FROM BASE SECONDS
		CODE	STAGE	CHN	
	SPECIAL SEQUENCE FOR VEHICLE TELEMETRY CALIBRATION				
VARIABLE	TELEMETRY CALIBRATOR IN-FLIGHT CALIBRATE ON	0010 0010	IU	23	ACQ + 60.0
VARIABLE	TM CALIBRATE ON	0100 1010	SIVB	62	ACQ + 60.4
VARIABLE	TM CALIBRATE OFF	0000 0111	SIVB	63	ACQ + 61.4
VARIABLE	TELEMETRY CALIBRATOR IN-FLIGHT CALIBRATE OFF	0001 0010	IU	24	ACQ + 65.0
	CCS ANTENNA SWITCHING COMMANDS				
VARIABLE	CCS COAX SWITCH-FAIL SAFE + HIGH GAIN ANTENNA	0000 0111	IU	63	VARIABLE
VARIABLE	CCS COAX SWITCH-OMNI ANTENNA	0011 1010	IU	64	VARIABLE
VARIABLE	CCS COAX SWITCH-LOW GAIN ANTENNA	0010 1010	IU	65	VARIABLE

VIII. SWITCH SELECTOR CHANNELS WIRED  
IN VEHICLE BUT NOT PROGRAMMED FOR  
USE DURING FLIGHT

NOMINAL FLIGHT TIME HR MIN SEC	COMMAND	SWITCH SELECTOR			TIME FROM BASE SECONDS
		CODE	STAGE	CHN	
	P.U. ACTIVATE ON	0000 0010	SIVB	5	
	P.U. ACTIVATE OFF	0010 1101	SIVB	6	
	AMBIENT HE SUPPLY SHUTOFF VALVE CLOSED ON	0110 1110	SIVB	20	
	P.U. FUEL BOILOFF BIAS ON	0100 1111	SIVB	34	
	P.U. FUEL BOILOFF BIAS OFF	0001 1110	SIVB	35	
	LH2 TANK VENT VALVE OPEN	0011 0001	SIVB	38	
	FM/FM SYSTEM ON (EFF. 509 AND SUBS)	0100 0010	SIVB	46	
	FM/FM SYSTEM OFF (EFF. 509 AND SUBS)	0110 1101	SIVB	47	
	HEAT-EXCHANGER BYPASS VALVE CONTROL DISABLE	0000 1110	SIVB	51	
	P. U. MIXTURE RATIO 5.5 ON	0100 1001	SIVB	66	
	S-IVB ENGINE EDS CUTOFF NO. 2 ENABLE	0011 0111	SIVB	67	
	LH2 TANK VENT VALVE CLOSE	0100 0110	SIVB	76	
	CHILLDOWN SHUTOFF PILOT VALVE CLOSE ON	0101 0101	SIVB	91	
	L0X TANK VENT VALVE OPEN	0010 0101	SIVB	93	
	L0X TANK VENT VALVE CLOSE	0000 1011	SIVB	94	

NOMINAL FLIGHT TIME HR MIN SEC	COMMAND	SWITCH SELECTOR			TIME FROM BASE SECONDS
		CODE	STAGE	CHN	
	FLIGHT CONTROL COMPUTER SWITCH POINT NO. 7	0001 1101	IU	7	
	EXCESS RATE (P,Y,R) AUTO-ABORT INHIBIT ENABLE RESET	0111 0010	IU	13	
	RATE MEASUREMENTS SWITCH	0001 1111	IU	17	
	EXCESS RATE (ROLL) AUTO-ABORT INHIBIT RESET	0110 1110	IU	20	
	FLIGHT CONTROL COMPUTER SWITCH POINT NO. 9	0101 1101	IU	27	
	EXCESSIVE RATE (P,Y,R) AUTO-ABORT INHIBIT RESET	0100 1110	IU	41	
	EXCESSIVE RATE (ROLL) AUTO-ABORT INHIBIT ENABLE RESET	0101 1110	IU	42	
	FLIGHT CONTROL COMPUTER SWITCH POINT NO. 5	0011 0010	IU	44	
	FLIGHT CONTROL COMPUTER SWITCH POINT NO. 8	0110 1101	IU	47	
	C-BAND TRANSPONDERS NO.1 AND NO.2 ON	0111 0100	IU	54	
	C-BAND TRANSPONDER NO. 1 OFF	0110 0100	IU	55	
	C-BAND TRANSPONDER NO. 2 OFF	0101 0100	IU	56	
	CCS TRANSMITTER INHIBIT ON	0011 1001	IU	58	

