



DSI AITS Newsletter

DECEMBER 2021

Values, Pointers, References, and other Memories

[Abraham John, Asst VP, DSI AITS]

A staff member in DSI AITS recently engaged me in a conversation about some LinkedIn C++ training he was taking. He observed that there is a construct in C++ called pass by reference and he expressed that it appeared to be just a different way of saying pass by pointer. My "fluff" article for this issue came from that observation since it brought back memories from long ago when writing code was an integral part of my job at UNT. This time there will be some bits, bytes, and just a few lines of quite simple code 😊 as we explore this extremely basic concept of passing by value, pointers, and references.

Using arguments in a function call to pass variables is nothing new and is necessary when writing programs and the program needs more than just the main() function. The question of how variables are passed is at heart of the observation made by the staff member.

Delving into this extremely basic of concepts in C & C++ language brought back memories when systems were developed in-house, and most things were not available off-the-shelf. My journey into C started in the mid to late 80's with Borland's Turbo C compiler and that venerable book by Brian Kernighan and Dennis Ritchie called The C Programming Language. As I moved to C++, books by Bjarne Stroustrup took center stage.

Reading Borland C's manual is a memory I cherish since it allowed me to learn a new language and to write useful systems for UNT with the knowledge gained. I know what you are thinking – reading a programming language manual and the word "cherish" do not really go together 😊. Yes - I know, just a bit strange in that way but maybe not, since as a boy I also spent many hours observing a mongoose family in their comings and goings without disturbing them, just to see how they behave. This was one of the many escapades and engaging activities I undertook as a boy. But on to the reason for this article. There are three ways to pass variables from a calling function to a called function. You can **pass it by value**, **pass it by pointer** or **pass it by reference**. Of these three, pass by reference is implemented in C++ and not C. For the non-coders, regardless of how variables are dealt with, they all occupy a space in memory and there is a unique memory addresses associated with each variable that is allocated at run time i.e., when the code is executed. Just to dip our toes into memory architecture: variables are typically stored in the region allocated for stack memory and is managed by the computer. Variables in the stack cannot be resized. Heap memory location is used for dynamic memory allocation. As a programmer you have used heap memory if you have used the malloc() or calloc() ways of allocating memory. I will defer a detailed treatment of stack and heap for another issue.

Every variable that is passed by value to a function, is created as a copy in the called function and scope is limited to the called function i.e., the variable in the called function is not accessible or visible outside that function. The point to keep in mind is that actions performed on the copy in the called function have no effect on the original i.e., the one in the calling function. They occupy two different memory locations and, other than the event of the value being passed they are effectively



Enjoy this brain teaser 😊

How can numbers 10, 0, 22, and 12 be logically combined into an equation, using each number only once?



Ocean sunfish



two different variables. In this snippet of code, you will see an example of pass by value.

```
#include <cstdio>
#include <iostream>
using namespace std;

void squareTheValue(int y)
{
    cout << "Value of y that is passed in by value to squareTheValue() as a parameter from: " << y << '\n';
    cout << "Address of y in squareTheValue() where x is passed in by value as a parameter from main():" << &y << '\n';
    y = y * y;
    cout << "Value of x in squareTheValue() after it has been squared:" << y << '\n';
}

int main()
{
    int x = 6;
    cout << "Address of x in main() function:" << &x << '\n';
    squareTheValue(x);

    cout << "Value of x after the returning from squareTheValue() call: " << x << '\n';
    return 0;
}
```

```
Address of x in main() function:006FFDBC
Value of y that is passed in by value to squareTheValue() as a parameter from main(): 6
Address of y in squareTheValue() where x is passed in by value as a parameter from main():006FFCE8
Value of x in squareTheValue() after it has been squared:36
Value of x after the returning from squareTheValue() call: 6
```

You can see from the output of the code, the memory locations for the two variables are different. Variable x has an initial value of 6 and an address of **0x006FFDBC**. Once it is passed to the function squareTheValue, the address of that copy, variable y is located at address **0x006FFCE8**, and the value is 6 as expected. The squaring changes variable y's value to 36. When control returns to the main() function, you will notice that the value of variable x in the main() function did not change.

You can also pass variables as a pointer to a variable. A pointer is nothing but a variable that points to the memory location of the variable it is referencing. The value of a pointer variable is the memory address of the variable it points to. The pointer is dereferenced to use the value at the memory location it points to, and any operation done to the contents of that memory location will be reflected when control returns to the calling function. In this snippet of code, the same squareTheValue function is being used, except this time the variable is being passed in as a pointer.

```
#include <cstdio>
#include <iostream>
using namespace std;

void squareTheValue(int* y)
{
    cout << "Value of y that is passed in by value to squareTheValue() as a parameter from main(): " << *y << '\n';
    cout << "Address of y in squareTheValue() where x is passed in by value as a parameter from main():" << y << '\n';
    *y = *y * *y;
    cout << "Value of x in squareTheValue() after it has been squared:" << *y << '\n';
}

int main()
{
    int x = 6;
    cout << "Address of x in main() function:" << &x << '\n';
    squareTheValue(&x);

    cout << "Value of x after the returning from squareTheValue() call: " << x << '\n';
    return 0;
}
```

```
Address of x in main() function:012FFC74
Value of y that is passed in by value to squareTheValue() as a parameter from main(): 6
Address of y in squareTheValue() where x is passed in by value as a parameter from main():012FFC74
Value of x in squareTheValue() after it has been squared:36
Value of x after the returning from squareTheValue() call: 36
```

From this output you can see that the address for the variable x in main() is the same as the value for variable y in squareTheValue(). The squaring operation being performed in squareTheValue() function changes the value at the memory location of the variable initialized in main() and the scope of that change is not just limited to squareTheValue() function where the operation is performed. When control returns to main() the value of x is 36 and not 6.

Pass by reference is a construct that is found in C++ and behaves like a pointer in that it references the same memory location of the variable in the calling function. The difference begins with how the variable is passed. The reference is the same object or variable and it can be a different name. Regardless of what it is called, it



Glass frog.



is still operating on the same memory location. This snippet of code illustrates the use of pass by reference.

```
#include <stdio>
#include <iostream>
using namespace std;

void squareTheValue(int& y)
{
    cout << "Value of y that is passed in by pointer to squareTheValue() as a parameter from main(): " << y << '\n';
    cout << "Address of y in squareTheValue() where y is passed in as a reference parameter from main(): " << &y << '\n';
    y = y * y;
    cout << "Value of y in squareTheValue() after it has been squared:" << y << '\n';
}

int main()
{
    int x = 6;
    cout << "Address of x in main() function:" << &x << '\n';
    squareTheValue(x);

    cout << "Value of x after the returning from squareTheValue() call: " << x << '\n';
    return 0;
}
```

```
Address of x in main() function:005EFD70
Value of y that is passed in by pointer to squareTheValue() as a parameter from main(): 6
Address of y in squareTheValue() where y is passed in as a reference parameter from main():005EFD70
Value of y in squareTheValue() after it has been squared:36
Value of x after the returning from squareTheValue() call: 36
```

From this output you can see that, just as with a pointer, the memory location being modified is that of the variable x defined in main(). When control returns to main(), the value of variable x has changed as a result of the operation in squareTheValue().

So, what is the difference in passing by reference vs. passing by pointer? For one passing by reference is safer since a reference cannot be NULL i.e., the reference must be initialized. A pointer stores the memory address of a variable while a reference just creates an alias i.e., another name for the same variable. A dereferencing operator * is used to get to the value of the variable the pointer points to while there is not dereferencing operator needed for a variable that is passed by reference. A pointer variable can be reassigned to another address while a pass by reference variable cannot be reassigned to another memory address. For a pointer we use the & to refer to the address of the variable it points to while the & operator is used to get the address of the of the reference.

I hope you found this quite simple "fluff" article useful in answering the question that, I am sure has kept you awake many nights about the differences between pass by value, pass by pointer, and pass by reference 😊.

The Helpdesk of the Future – methods and technologies to enhance the support experience

[Sharukh Mithani, Samuel Wiggins, Richard Sanzone, DSI AITS]

Providing IT support is a balancing act between security, everyday functionality, and customer service. There are almost limitless factors that we must be aware of when we respond to any user, whether experiencing an error or just seeking guidance on how to perform a task.

By re-examining our workflows and introducing new methods of communication, we can improve service and reactions without the need for rote memorization by our technicians. By influencing and improving the communication process between both administrators and customers, we are more quickly and easily able to find solutions for our users.

Live Chat and Virtual Agent

One way the Helpdesk is streamlining the communication process is Live Chat through ServiceNow. Live Chat is quickly becoming a popular option with our customers and creates a much easier workflow for technicians as well. Live Chat allows technicians to help more than one customer at once. Additionally, it allows for ServiceNow, UNT's IT Ticketing System, to capture the entire interaction. This streamlines the escalation process and ensures that if follow-up work is needed, the user will not need to repeat any information.

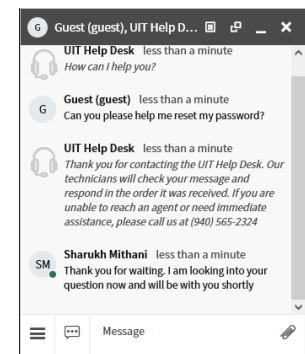

Soon, we will also be implementing the ServiceNow virtual agent, which presents users with support topics before being transferred to a live agent. This tool will allow users to get help with common support topics, but without the need for a live agent to be present. This can help with after-hours support interactions and reduce the volume of support during busier times.

Situation Behavior Impact (SBI) based support

SBI, or "Situation Behavior Impact" based support, is another way to streamline services that have either accumulated too many moving parts or not been reviewed in some time. This requires Support Managers to routinely check on the outcome of past tickets and using that to influence future decision making. Not relying on canned answers and instead using a system of support we can create more effective support groups that are focused on solutions. Changing and creating a live interaction rather than a copy pasted one not only helps us as technicians but also helps users—Whether that is through adding routes of communication or taking away extraneous processes that only slow the user or technician down, changing processes is one of the most important parts of supporting a user base.

SBI can be used as an equation or workflow for solving issues around communication which so often is our biggest hurdle, whether it's communicating with the user or interpreting the values a system gives us while checking a user account. With the context of a past issue, you can investigate first the situation the user was in, what was wrong, or what needed to happen. Looking at what caused the confusion or the feedback, we can easily decide the impact or real problem which helps either the user or technician to correct the situation.

Using this method, the Helpdesk found that many tickets went unsolved because customers were not able to reach us at a time convenient to them. For this reason, the Helpdesk now offers a scheduled call-back service, using Microsoft Bookings, to allow a user to be reached at the time most convenient to them. This is particularly important when a procedure requires over the phone security verification, but a user only has a small period during the day when they are available to talk to us. A



Goblin Shark.



technician or manager is automatically scheduled to handle the call based on the user's availability and our Outlook calendar.

The Sherlock Holmes Method

By contextualizing issues and errors, we can deduce what matters and what does not, much like a modern-day detective would. Using systems like SBI require you to break down real life problems into components that can be investigated defining the IT equivalent of "clues" which not only helps to simplify and streamline processes but also gives the excitement of being a real-life Sherlock Holmes.



Most issues (and crimes for that matter) would be more easily solved if users (or victims) could call someone and tell them exactly what is wrong or what to look for. However, most users only have one part of the puzzle: the impact. It's up to us as IT professionals to do our best to investigate and deduce what areas are worth looking into and which are not. The most direct way to affect the users experience to this is to examine and improve the support received at the Tier 1 and Tier 2 levels. Streamlining the start of the user's experience is the best way to ensure that they not only get started on the right journey, but that it's also in the right direction (i.e., To the correct department)

Agile Workforce and Virtual Workspace

Working through the pandemic has taught us innovative methods to get the job done. We've embraced the concept of the agile workforce, which is a strategy to dynamically add employees to the live service on-demand during heavy workload. Additionally, utilizing a virtual workspace in addition to the traditional office space has greatly expanded our ability to provide service. Employees can perform their duties remotely by leveraging technology such as remote desktop, voice-over-ip phone systems, and software collaboration spaces such as Teams and Zoom.

Looking Forward

Looking towards the future, we can expect innovative technologies, like AI-based support and cloud services, to continue to influence the Helpdesk experience. But one thing is clear: Today's Helpdesk *is* the "Helpdesk of the future". It's a constantly evolving service ensuring that the user experience is continuously improving, to the benefit of our technicians and our organization.



Shoebill.



Browser Wars

[Lazayvion Hammick, Sr. Cross Functional IT Specialist]

When most people search for the program to browse the internet, people usually gravitate toward these four web browsers: Google Chrome, Mozilla Firefox, Microsoft Edge, & Apple's Safari.

This article will cover a brief introduction to each of the Big 4 major web browsers used today and why someone may consider switching to one or the other.

Google Chrome currently leads the browser wars with the highest market share in the industry and has been since 2008. Its seamless integration with Google services and simple interface makes it a top pick among internet users. While Chrome is among the fastest web browser on the planet, one of the main drawbacks with Chrome is it is resource intensive and associated with Google, a company that has been in the news about the handling of its user's data.

Pros: Speedy Performance, Best compatibility with websites across the web, Tight Google integration.

Cons: Not as privacy focused as competitors, Resource Intensive.

Firefox used to be #1 before Google Chrome made its debut. While it is still considered to be an all-purpose browser due to its excellent mix of customization, privacy, and extension support, many web developers choose not to develop their sites for Firefox due to Chrome and its Chromium variants having a much larger user base which leaves users flocking to other browsers or using more than one browser simultaneously.

Pros: Privacy focused. Free from the big 3 (Microsoft, Apple, & Google). Multi-Account Containers,

Cons: Lacking in compatibility with a few other websites (e.g., Microsoft Teams, Apple owned websites)

Microsoft Edge was released in 2015 but was completely overhauled in early 2020. Edge is now fully based on the Chromium engine, the same rendering engine used by Google Chrome. Microsoft Edge has a full host of privacy controls in an attractive user interface. Edge is built into Windows, so no installation is needed.

Pros: Built on the same foundation as Google Chrome, Strong Privacy protection, keeps compatibility with Chrome extensions. New features added often. Functional and Informative New Tab page.

Cons: Forced to be the default browser for Windows computers.

Safari, exclusive to Apple devices is regarded as the best browser for Apple devices. Very minimal controls (user customization, appearance & limited availability of extensions)

Pros: Super Tight Integration in the Apple ecosystem, Solid Privacy Protection, A no-brainer for macOS.

Cons: Not available to non-Apple devices

Take each browser for a test drive and see how you may like it. You may be surprised how better another browser may be over the one you may be currently using.

The Final Verdict:

For Windows: Microsoft Edge – best combination between speed, compatibility & privacy on Windows.

For macOS: Safari – best performance and privacy on Apple's platform

For all other platforms: Mozilla Firefox – an all-purpose browser for every other browser and a solid alternative to Edge.



Pink fairy
armidillo.



Why Companies are Rejecting Outsourcing

[Alexandra Martinez]

Why are most companies trying to bring their offshore operations back to home soil? Outsourcing has proven to be the right approach for certain companies at different points in time. Outsourcing can definitely have its advantages when it is constructed and carried out in ways where it drives down costs, has a clearly defined scope, and allows the company to focus on what it wants to do. Critical business functions depending on the firm could be at risk when outsourcing, even to domestic companies that use foreign subcontractor whose rights to deliver services and/or receive payments could be affected for political reasons. Outsourcing can also cause morale and cultural climate issues for the in-house employees. There are numerous angles that this could be approached and dissected. Implementation of outsourcing may negatively impact the company as employees will lose faith in their employer, driving them further and further away. Rising costs to pay those outsourcing workers, unlike the nickel and dimes that they were once paid, have been a deterrent for companies to outsource work. That was once the highest factor to outsource. Couple that with the rising costs of transporting goods back to the states, especially with the drama with the cargo ships in today's world. In this report, we will dive into the many ways that outsourcing is being rejected by more and more companies.

Failure to Meet Expectations

There are multiple avenues and reasons why outsourcing would fail to meet expectations. When a company is looking to expand and grow, a higher need for things such as increased production, additional IT support and customer care as the consumer base grows. While a lot of companies might hire new talent to take these reigns, a lot of companies might outsource to external companies for this support. Outsourcing tends to be synonymous with higher production at reduced cost. That can be a major point of failure in terms of expectations. Those you outsource, could exaggerate their competencies and skills, as the outsourcing company, you have no say in the quality of knowledge that those people completing a job for you have. Lack of communication as well as any language barriers could cause a multitude of issues if not properly addressed. The quality of work can be an issue if not closely monitored as well. If you are using in-house work, you can have your hand in the process and product all the way through, something you can't always have when outsourcing. This can cause the quality of the product or service to deteriorate as well. It can be a classic "you get what you paid for" type of situation. Outsourcing can also pose some political issues and give the company a bad image in the public eye. "Taking away jobs from Americans" is a common argument that companies will face when presented with the opportunity of outsourcing. Conflicting interests between you and your outsourcing partners can cause rifts in the product cycle. These are some common themes in that outsourcing can fail to meet a company's expectations when and if they decide to go that route for a product or service.

Desire for In-house Expertise Within Companies

A company may desire to set a competitive plan for building broader in-house service capabilities. These in-house service capabilities will benefit faster market product cycles, revenue generation, increased innovation, and intellectual property protection throughout the business process. Moreover, these capabilities also affect the use, or continued use, of outsourcing arrangements. On the other hand, political pressure also contributes to insource operations on public relations.

Marketplace Pressures

There are several elements of pressures from the marketplace to affect the outsourcing industry. First of all, dynamics play a vital role in the outsourcing market. Dynamics create challenges to outsourcers for maintaining their value propositions. Second, wage inflation mainly puts pressure on outsource providers to keep concern on finding alternative delivery locations and adjusting their staffing mix in order to make them financially competitive. These changes are seen as reducing quality. Moreover, "job hopping" is another pressure which some companies focus on within their labor pool. The "job hopping" decreases the stability of the delivery solution. If put these elements of pressures together, these different



Red loipped batfish.





**Hummingbird
hawk moth.**



elements would let customers make options for in-house solutions, like declining to renew existing agreements or executing termination rights available in current agreements. In general, offshore outsourcing will not be extinct. Some outsource companies, which concern offshore locations, would need to prepare enough for this potential possibility.

Financial Segmentation of Outsourcing

Another area in which businesses should concentrate is financial segmentation. Knowing how in-house and outsource services stack up financially is very beneficial for company success. Companies must establish detailed financial tracking to allow for future cost comparisons. If a company decides to insource some of its IT services, it will of course need to segment its costs sufficiently to compare the outsource provider costs to the in-house alternative on a like for like basis. The company should maintain adequate visibility into all aspects of its delivery solution's finances, including hardware and software asset costs, monitoring tools in place, and so on. Allocating costs provides perspective while weighing out the differences.

Desire to Train and Keep In-house Employees

Seeing the cost burden of outsourcing, of course companies would seek to train their own employees as opposed to external parties. Heavy reliance on external parties may be detrimental to a company as it can lead to a loss of market performance. When relying on others for your work, you may sometimes get unexpected results. For example, an outsourcer may not deliver by providing a service lacking innovation. Whereas if it were in-house, service could be monitored and controlled. More and more companies are beginning to realize that utilization of their own resources is the best for business overall. Employee retention is vital to a company that seeks growth.

Contract Flexibility

Outsourcing agreements are typically not flexible due to the predefined work that it provides. The items that are usually predefined are the term of agreement, scope definition, service recipients, framework agreement, acquisitions, and divestments. Contracts usually last for about 3-5 years. Throughout the length of the contract both parties agree on the services that will be provided. After length and scope of services are agreed upon the outsource company often creates a catalogue of the services provided under the agreement, and the agreed pricing of the various services. In addition, the framework agreement is the overall rights and obligation of the company.

As a result, these items set a structure and are drafted in a way that both the client and outsource company agree on. Making it challenging for contracts to be flexible. Since the overall purpose of an outsourcing company is to satisfy its client's current needs, and not predict the future needs.

Conclusion

Overall, companies have realized outsourcing has a negative impact on business strategy, financially, business growth and innovation. These impacts also affect company morale and cultural climate issues for the in-house employees. Implementation of outsourcing negatively impacts the company as employees will lose faith in their employer, driving them further and further away. The rising costs of services provided by outsource companies. There's range of factors that drive companies to revisit the outsource or in-house provider equation. Even if an outsourcing agreement is properly functioning, it would be sensible to hold visibility, expertise, and versatility of their finances and service delivered.

Relevant Links:

[The Pros & Cons of Outsourcing to Offshore Companies](#)

[Why Some U.S. Companies Are Giving Up on Outsourcing](#)

[The Pros and Cons of Outsourcing](#)

[The Unintended Consequences of Outsourcing](#)

[Flexibility in outsourcing contracts](#)

Is the Metaverse our New Reality

[Reema Roy, Student Assistant]

Two months ago, I had my first experience with virtual reality when I tried on my brother-in-law's Oculus Quest headset. I remember the surreal feeling of seeing the screen and immediately being transported to a whole new dimension. I was able to enter different worlds and have conversations with other "avatars" that were playing from their living room as well. That was my introduction into the Metaverse. After a little bit more research I found myself immersed in the possibilities of how Meta (previously known as Facebook) could revolutionize everyday life. But not without some serious security drawbacks... Meta introduced the metaverse as the next evolution of social connection but offers limited resources about how they plan to secure the obvious vulnerabilities within their design plan.

What is the Metaverse?

In October of 2021, Mark Zuckerberg launched "Meta," bringing together all the apps and technologies under the now renamed Facebook brand. Meta's mission will be the creation of the Metaverse and the shared goal of bringing people together with the power of technology. The word "meta" derives from the Greek prefix meaning "after" or "beyond" and intentionally alludes to the idea of a "real," futuristic cyberspace. The Metaverse will be a network of virtual worlds that combines the online social interactions of today with augmented reality. It will be an immersive tool that brings people together for a shared experience in gaming, fitness, entertainment, etc. The possibilities are endless.



What to Expect

With the launch of Meta, the company released an hour-long video on their YouTube channel to get consumers eager about the endless possibilities within the metaverse. While they were met with great praise by many, the skepticism soon started to roll in tenfold. Watching the entire launch felt like a fever dream but here are the concepts that I think require a bit more discussion.

1. **Privacy and Safety:** With the controversy surrounding the Facebook brand, it's to no one's surprise why they changed their name to Meta. But do not worry, the lawsuits against Facebook for selling personal information about their users/compromising their privacy for money have not been overlooked. Meta insists that privacy and safety will be instilled into the metaverse from day one and go on to sell the idea that "you choose" when you want to be in the virtual reality space to begin with. You will be able to block people from appearing in your space or even teleport to an isolated pod for peace. Not much is mentioned about how their VR/AR technologies will be some of the most data-extractive digital sensors that will be seen in the market. In fact, Meta has already started collecting data including digital audio, objects, your VR movement and even your physical features such as hand size. Think about it like this... If you cannot even log into Facebook without being bombarded with a multitude of personalized ads, imagine the sheer amount of data you are compromising by inviting the same software into your home. Experts believe that the metaverse will ultimately be a replica of Times Square filled with brand deals and product placement. All we have so far is Mark Zuckerberg's word that privacy will be regarded in all aspects within the metaverse but as history shows, it is not his #1 priority.



Mantis shrimp.





Sun Bear.



- Horizon Home and Worlds:** While these already exist and can be accessed through Oculus Quest right now, they can be upgraded and will soon evolve once the metaverse fully comes into fruition. It will be to the point where everyone can create their own home space to emulate their real home or one that can only be achieved through augmented reality. In addition to that, Meta wants to create a social experience within Horizon home where you will be able to host gatherings or plan virtual reality birthday parties consisting of avatars of your loved ones. You will also be able to watch immersive videos together or even collectively jump into an app. Meanwhile, with Horizon worlds you can create and jump into personalized worlds to interact with your friends or have a shared experience within a world full of other avatars. While I do not mean to beat a dead horse talking about the concept of privacy and safety, I strongly urge you to take a look at the reviews left by individuals on the Oculus Quest website for [Horizon Worlds](#). Keep in mind that these are the reviews posted while the metaverse is still in its infancy. The amount of bullying and harassment happening within these virtual environments will be a formidable concern for developers. There are a variety of options to combat some of the hate speech and harassment, such as moderators. But from what we can see with Oculus Quest, no developments have been made yet. It is undetermined how Meta plans to censor or control the content produced by its users in order to create a safer environment for people of all ages.

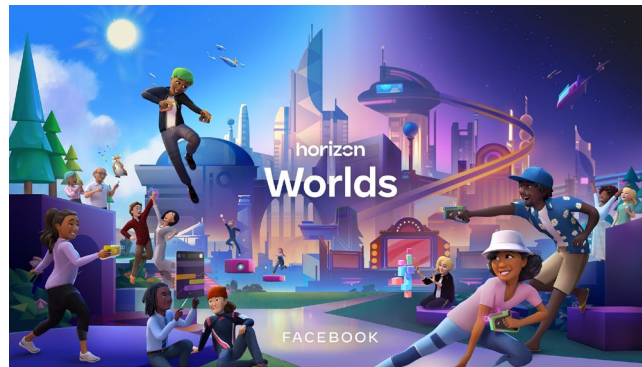

- Remote Work in the Metaverse:** Over the past two years, we have seen the power of remote/hybrid work and can conclude that it will be around for a long time. But what would work in the Metaverse look like? To begin with, Zuckerberg reassures viewers that there will be options available to create separate profiles for your work and personal Facebook accounts to maintain professionalism. Meta acknowledges that the biggest issue with working from home is often the loss of personal interactions with co-workers, and a sense of presence in a shared space. That connection with a colleague is what encourages business leaders to take a 3-hour flight for a 1-hour meeting. But Zuckerberg suggests that the same connections can be forged by shifting your meetings into the metaverse entirely. While the idea of an AR workspace is extremely interesting and could be a momentous change, there are a few drawbacks. Creating an efficient work environment through VR requires excellent technology and massive bandwidth to support. The more technology it requires to facilitate the metaverse, the more restrictive it becomes... Not to mention expensive. Significant advances in Meta's VR headsets as well as other accessories will also be required since what we have seen so far is not comfortable enough for long time wear and has been known to cause motion sickness. Back in September of 2021 we saw Facebook's collaboration with Ray Bans to release a pair of glasses called Ray Ban stories. They had no AR capabilities and simply served as a camera and microphone for point-of-view recording. Since then, Meta has announced the development of their prototype for AR glasses called Project Nazare but mentioned that it is still a work in progress. As Meta works towards implementing VR into the workplace, they are changing the meaning of hybrid from home-workplace into physical-virtual.



Lyrebird.



Building the Metaverse

Amongst the multitude of obstacles Meta will have to surpass in order to live up to the expectations they have set, there is promise in the sheer number of investments they have received. As Meta rebranded, tech giants such as Microsoft, Apple, Epic Games, Decentraland, and Meta themselves have almost immediately begun pouring millions into building the metaverse. By “building the metaverse,” I do not mean that it will be a single software platform but instead a complex digital world that relies on a decentralized, collaborative effort by 160+ companies. An analogy I read that presents this idea in simpler terms is that in the same way Google built parts of the Internet, tech companies like the ones listed above will work on the infrastructure of the metaverse among other elements. Soon we will be able to witness new innovations in e-commerce with the advancement of established cryptocurrencies such as MANA and SAND. We can also expect new interactive shopping experiences, real estate, virtual concerts, and video games among so much more. The final piece in the construction of the metaverse is you. User adoption will obviously play a major part in the success of the metaverse because without addressing consumer hesitance, Meta will see significantly less user generated content.

As “metaverse” continues to be a buzz word, it is extremely easy to get sucked into this partially fictionalized perspective of the future. Especially with an hour-long presentation mentioning such revolutionary ideas like interactions with holographic people and digitally teleporting to a concert your friend is at in real life. This is not the first time we have seen sensationalism in advertising for tech, but it makes us wonder which aspects of the vision we can expect to come to life. If consumers are aware and weary of all the vulnerabilities within this concept of the metaverse, it is possible to find a healthy balance between virtual reality and reality itself.



The Steam Deck May Just Change Things After All [Patrick Kennedy, Cross-Functional IT Support Coordinator]



Axolotl.



The unimaginable slew of technological innovations that have been presented to us as industry disrupters over the years have dulled the impact these claims could hope to carry so much so that it is hard to get excited when something new promises to change the way we see life, interact with computers, or slice bread. Google Glass was going to change how we digested information. The Segway was going to revolutionize public transportation as we knew it. Xbox Kinect was going to trick gamers into exercising with the ultimate marriage of gaming and physical fun. Years later, Google Glass lost to smart watches, the Segway influence fizzled into fire-prone hoverboards for children, and the Xbox Kinect gave way to virtual reality gear. While it could be argued that the hype generated by these bold ventures paved the way for what ultimately succeeded, the truth of the matter is that these ideas were looking to solve a problem with a flawed approach until something came along that did it *better*. Sure, I could defend myself with a very stale baguette, but I would imagine that a lightsaber would be a much more effective tool.

These flawed executions of good ideas give us the necessary perspective to experience the lightbulb, "I can make this better!" moments that follow through with the promise to disrupt markets made by their predecessors. So often companies will set out on an ambitious quest to make the end-all device but fall short because the technology simply isn't there yet. GM built the first modern mass-produced electric car from a large manufacturer, the aerodynamic bar of melted soap called the EV1, back in 1996, but it's likely you have ever seen one on the road. Go out today and you'll see electric cars are becoming commonplace because the technology and ideas matured until Tesla did it better. Porsche did it better. Lucid did it better. If you wind back the clock to 2013, Valve Corporation, famously known for their digital game distribution platform Steam, announced their new Steam Machines. They wanted to create Linux-based, affordable, small form factor gaming machines running their own SteamOS distro to offer gamers an alternative to the dominant Windows platform. In conjunction with this, they released the Steam Link and Steam Controller, allowing for gamers to stream their PC games to another room in their house using a controller that introduced brand new ideas with its thumb track pads. These hardware releases gained significant momentum and excitement that slowly faded into the background as Valve focused more and more on VR in the coming years. They were thought by many to have been curious experiments that fizzled out, but we didn't see the bigger picture: Valve was building something incredible right in front of everyone, and we never even saw it coming.

Valve took the lessons they learned from their hardware, waited until the technology caught up to their vision, and released their most ambitious and

important product since the Steam client: the Steam Deck. Simply calling the Steam Deck a portable console sells it short, as it's so much more than that. The Deck runs the latest iteration of SteamOS on AMD's Zen 2 and RDNA2 architecture that is conveniently packaged in a Steam Controller with a screen and battery. The Steam deck is a portable gaming computer capable of running modern titles such as Elden Ring, God of War, Forza Horizon 5, and so much more for a starting price of \$399. While there are storage upgrades to be had at two higher pricing tiers, the Deck is the most capable new gaming computer you can buy in those price brackets while being far more convenient and portable.

Choose your Steam Deck

Steam Deck is available to reserve now in select regions and has begun shipping to customers in the order reservations were made. Choose which version to reserve below. When inventory is available, you will receive an email and will have 72 hours to complete your purchase.

\$399.00	64GB eMMC	\$529.00	256GB NVMe SSD	\$649.00	512GB NVMe SSD
<ul style="list-style-type: none"> Carrying case 		<ul style="list-style-type: none"> Faster storage Carrying case Exclusive Steam Community profile bundle 		<ul style="list-style-type: none"> Fastest storage Premium anti-glare etched glass Exclusive carrying case Exclusive Steam Community profile bundle Exclusive virtual keyboard theme 	
<p>Login for reservations</p> <p>Expected order availability: After Q3 2022</p>		<p>Login for reservations</p> <p>Expected order availability: After Q3 2022</p>		<p>Login for reservations</p> <p>Expected order availability: After Q3 2022</p>	

Effective storage capacity subject to change based on size of operating system and formatting technology. All models include a microSD slot for additional storage capacity.



Parrot Fish.



It is by no means the first gaming portable gaming PC, as AYA NEO will happily sell you a less capable device for \$1000 or more, but it's one that looked back carefully enough to propel things forward. The Nintendo Switch is a fun console that delivers a fine experience, but it's a locked-down ecosystem, so you are limited to the software Nintendo offers and approves of. Conversely, the Deck is yours to do whatever you please with. Want to load Windows 11 instead? Valve released drivers for it. Don't like the settings the game runs at? Change whatever you want. Want to emulate the Switch to run Breath of the Wild at 60 FPS? Download an emulator and have fun (legally speaking, you should own a legal copy prior to doing this). Valve has an ever-growing list of verified games that you can download and play with no tweaking necessary, but they'll let you run whatever you want regardless of approval since it's *your* device. It's an incredibly refreshing feeling to see a company release a product that offers the freedom to do whatever you want to a product you rightfully own, even if it costs them money and time to allow it. They reinforced this belief in the customer by releasing the device's CAD files for custom accessories, offering replacement parts, and partnering with iFixit to offer instructional guides for repairs and upgrades. You don't even need to buy the higher level storage options, as Valve worked to make it easy to upgrade the storage yourself with a bigger SSD, and you can even run games off of a MicroSD card with impressive performance.

If Valve were to try and solely maximize profits, many of this wouldn't make sense financially, but Valve's team of talented developers and engineers set out to make the best possible device they could make for only \$100 more than the aging Nintendo Switch. Many Valve employees had been dreaming of a device like this for decades, so this became a passion project for them. It takes a special team of like-minded individuals to pull something like this off, as it requires significant effort and a unified vision. The end result is a product that aims to succeed in a class of its own, and it has some interesting tricks up its sleeve to deliver on that. Linux is a traditionally under-supported platform, and Valve knew that in order to incentivize users to rely on SteamOS for gaming, they would need to allow compatibility with games that are traditionally only available on Windows. By working with CodeWeavers, Valve codeveloped the Proton compatibility layer to make running Windows games as simple as hitting "play." While it does not perfectly support every game, there are already, at the time of writing, 741 "Deck verified" and 1359 "verified or playable" titles listed on the Proton database. This doesn't include the other games that will work with some tweaking, or games that haven't been tested

yet, so the real figures could be much larger. When you consider that you can emulate many other consoles, the number grows far larger.

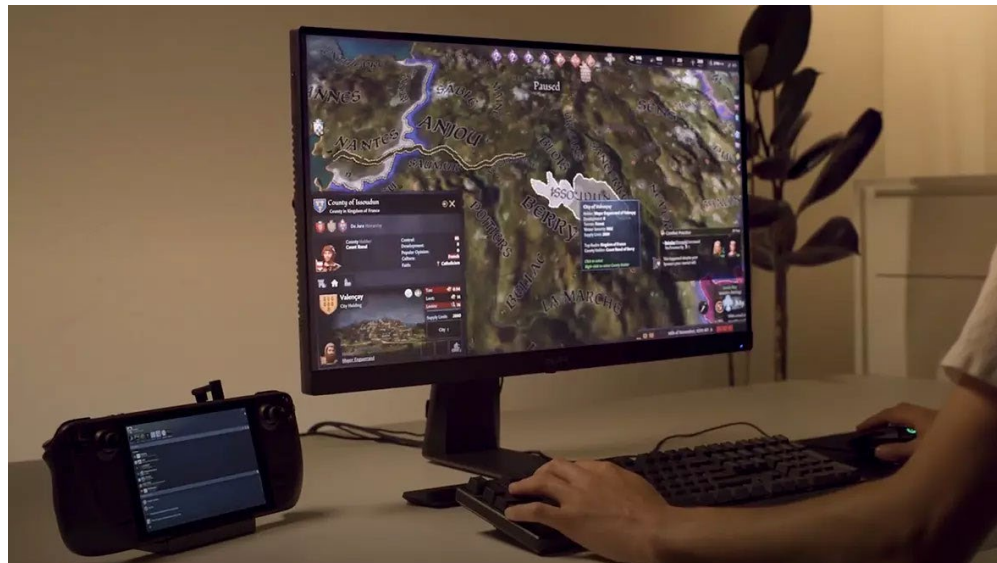

Purple frog.



The Deck can also utilize Steam's game streaming capabilities to remotely play a game from your home PC while away to further stretch the library of games offered. Furthermore, it can be plugged into the upcoming dock for use as a desktop, and even launch games from other distribution platforms such as Epic's. It's not to say that everyone's Deck experience will be perfect, as the double-edged sword of an open platform cuts both ways. Since traditional game consoles are locked down to only approved software, they *usually* deliver a playable experience. Conversely, the Deck gives users the freedom to try out whatever they want, even if it doesn't work. For some like myself, the tweaking of settings and optimizing for battery life or visual fidelity is a fun experience, whereas other people just want to pick up a console and launch a game with zero tweaking. Thankfully the validated titles list exists to give users that plug-and-play experience, but they may get frustrated troubleshooting unsupported titles. Moreover, SteamOS is very much in active development, with some news outlets reporting that it can feel unfinished at times. Thankfully Valve is releasing updates and patches nearly every day, but you are buying into the promise that they will continue to develop and improve the user experience.

I truly believe that the Steam Deck will put a capable gaming PC in the hands of more users than ever before in an age where finding an affordable graphics card can feel like an impossible task. The Steam Deck seizes the opportunity afforded by the maturity of key technologies, like AMD's power-efficient architecture or FidelityFX Super Resolution, to deliver an experience that will change how and where we play PC games. With a 40Wh battery delivering between 2 to 8 hours of game time depending on the title and settings chosen, you can play nearly your entire Steam library from anywhere. As of right now, if I want a somewhat portable PC gaming experience, I use my existing gaming laptop. The device itself is unfortunately expensive, the fans sound like an F22 fighter jet taking off, I almost always need to have it plugged into an outlet capable of supplying 230W to play modern titles, and I have to carry it around in a laptop bag or backpack that can fit my bulky charger, controller, mouse, headset, and more. While I love having a powerful PC I can take with me to LAN parties, the setup is far too clumsy and power-hungry to ever hope to use on a plane, bus, or road trip. The Steam Deck fits everything needed to play your games into its included case that houses the 65W charger, allowing it to plug into a plane's ~75W outlet or a 120W car outlet. Furthermore, it can be put into a sleep state at any time, shoved into a backpack, and then woken back up to resume the game where you left off when you arrive at your next destination. If I were to move my gaming laptop to a second location, I would need to save and fully close out of the game, pack up all the accessories, and completely power off the laptop so it doesn't overheat in my bag, as it still must ramp the fans to annoying speeds in hibernation mode.



**Japanese
Spider Crab.**



Learning from the inconveniences, successes, and failures of the past allowed Valve to create something that takes a lot of good ideas and make them into something that is just better. Apple's first iPad in 2010 was not the first tablet computer, but it was the first tablet computer that did things well enough to excite the masses and solidify tablets as a normal device in people's lives. The Steam Deck is the iPad of the portable PC gaming space; it will become a device class that coexists with desktop PCs for many and replaces it entirely for others. And just like the iPad, it will encourage others to build competing products that offer customers more choice in this growing space, and more choice is always nice, right? And yes, it can run DOOM.

Logic Gates

[James Taylor, Cross-Functional IT Support Supervisor]

At a basic level, computers operate in binary code; that is to say, that everything that a computer does can eventually be broken down into ones and zeroes. Abstractly, we can imagine long streams of ones and zeroes traveling down wires and through digital circuits at incredible speeds to perform whatever task we require of the computer. Physically, electricity is passing through the computer's circuits and, depending on the level of voltage, is interpreted logically as a zero or a one (or "false" and "true"). In computer science, we abstract the physical details of how a computer works so that we can work with the ones and zeroes on a logical level without having to worry about voltage ranges and thresholds for every problem.

Computers manipulate binary data by using logic gates, which are essentially the building blocks of digital circuits. Logic gates accept a logical (electrical) input and produce an output, depending on the type of gate.

The simplest type of gate is called a NOT gate. It accepts one value, either a 0 or a 1, and inverts it.

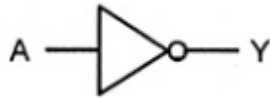

Figure 1- NOT gate

For example, if the input value (A) equals 0, then the output (Y) will be 1. In the opposite case, if A equals 1, then Y will equal 0. This can be seen in the truth table below which contains all the possible inputs and their respective outputs.

A	Y
0	1
1	0

Figure 2- NOT gate truth table

Most logic gates, however, have two inputs, A and B though there is still just a single output.

The AND gate takes two inputs and produces a 0 output in most situations while an OR gate produces a 1 output in most cases.



Figure 3- AND gate

From the truth table below, you can see that the AND gate produces a 1 output when both A and B equal 1 and that it produces a 0 in all other situations.

A	B	Y
0	0	0
0	1	0
1	0	0
1	1	1

Figure 4 - AND gate truth table



Jerboa.



The OR gate on the other hand, produces a 0 when both A and B equal 0. Essentially, if at least one input equals 1, it will produce a 1.

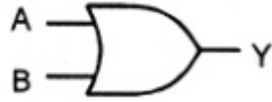

Figure 5 - OR gate

A	B	Y
0	0	0
0	1	1
1	0	1
1	1	1

Figure 6 - OR gate truth table

One more gate that I will introduce is the NAND gate, also known as the NOT-AND gate. As you might suspect, it produces the opposite outputs than what you would get from the AND gate. Whereas an AND gate produces a 1 only when both A and B are equal to 1, the NAND gate produces a 0 only when both A and B are equal to 1.

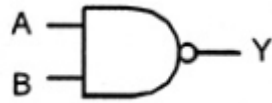

Figure 7 - NAND gate

A	B	Y
0	0	1
0	1	1
1	0	1
1	1	0

Figure 8 - NAND gate truth table

These gates and several others that I have not introduced here can be linked together in various ways to produce more and more complex arrangements.

Below, we have an AND gate whose output provides the input for a NOT gate. As you might have guessed, we have essentially created a NAND gate out of two other gates. The truth table will look exactly as that in Figure 8.

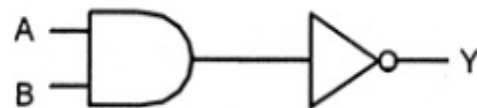

Figure 9 - AND gate connected to NOT gate

If we supply a 1 for input A and a 1 for input B, the AND gate will output a 1. That will then be supplied as the single input for the NOT gate which will invert it and output a 0. Any other combination of values for A and B will produce a 1 output from the NOT gate.

You can begin to see how much more complex combinations of gates can be arranged to perform very basic logic problems. The average computer that we use from day to day contains *billions* of gates. These gates are physically implemented using an electronic component called a transistor. Manufacturers are now able to create transistors around 45 nanometers in size. To give you a sense of scale, a typical bacterium (such as *E. coli*) is about 5 micrometers in size which is about 100 times larger than a modern transistor!



Blue dragon.



Now that you have some knowledge as to how logic gates work, try your hand at the exercise below:

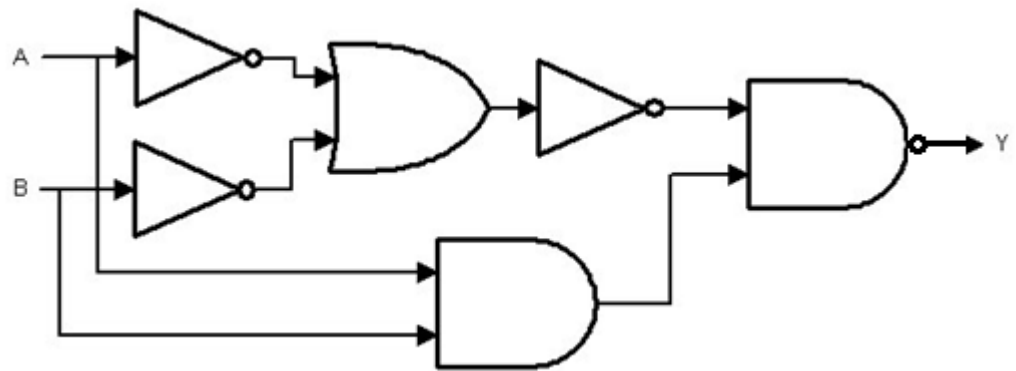

Figure 10 - Logic gate exercise

A = 0; B = 1; Y = ?

**Note that A and B are providing inputs to more than one gate*

***You can find the solution in the next edition of the AITS Newsletter*



Comb jellies.



Intro to Access Databases Part I

[Matthew Trammell, Cross-Functional IT Support Supervisor]

Data exists all around us. Without organization, data is not very helpful to us at all. For example, take a look at this list of eight items, purposefully arranged in a random order:

Desktop 1	Chestnut Hall OptiPlex 9090	In Use Matt Trammell	DSI AITS DSA Dell
--------------	--------------------------------	-------------------------	----------------------

Do you have an idea of what the above list represents? Did you guess a Computer Inventory? Well done! Inventory has been fresh on my mind since I recently assisted our team in generating a report of computers, both desktops and laptops, that were out of warranty. Our DSI Administrative IT Services DSA team alone supports around 900 computers. Imaging having 7,200 items, 900 x 8, floating around and trying to make sense of that. Oh, the horror! If we truly want to understand the data we collect, we must first organize it. Fortunately, there are tools available to help us do just that. Two common tools are Microsoft Excel and Microsoft Access. Most people are familiar with Excel and as such, would choose Excel over Access. However, do not dismiss the power of a well-designed Access database!

If you research the two tools, you will find that Excel is well-suited for financial and statistical analysis, whereas; Access is best suited for collecting, querying, and reporting data. Excel may be a bit easier to learn and utilize. However, it is my hope that after reading this article series, you will feel a bit more confident with Access and be able to find some uses for this powerful program in your professional and personal lives. As I started putting together this article, I realized that I could easily write 10 pages or more of information. Thus, I decided to break down my content into two articles. In this article, I will focus on storing and collecting data using tables and forms. In my next article, I will continue on to introduce queries and reporting. Speaking of my articles, did you come up with the answer for the magic sum of a 49x49 magic square? The answer is **58,849!**

Note: If you do not have Access, please review this Microsoft website for information on how to get it: <https://www.microsoft.com/en-us/microsoft-365/>. Do not worry if you are unable to get a copy. I will try to include screenshots to help you visualize setting up an Access database.

Tables

In Access, you use tables to store data. Tables consist of **fields** (columns) and **records** (rows). So, let us go ahead and open Access. You will create a blank database. Choose a save location for your database and give it a wonderfully creative name, ComputerInventory.accdb. Viola! You are inside your Access database with a blank table to fill out:

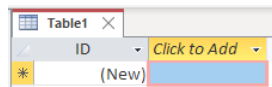

Before we move on further, take a look at the eight items of data that I collected and come up with a header or field name for each item. In my example above, I collected the Type, Location, Status, Department, ID, Description, User, and Manufacturer. Now, I will apply a little sorting magic within my head and arrange my fields as so: ID, Department, Status, Type, Manufacturer, Description, User, and Location. If you want to change the order, go ahead and have fun! Did you catch that Access already provides the ID field for you?

The ID field is the default primary key. Each record should have a primary key for creating relationships between tables. For a computer inventory, I would most likely

 Ankole
Watusi.



use the Serial Number, UNT number, or Dell Service Tag as a primary key. However, for this article, let us use the default ID field to keep things simple.

Therefore, we simply need to add the seven remaining fields. Click on "Click to Add". You will note several possible field types. However, for this article, we will only work with the Short Text field type. Sorry other field types!

After you select the Short Text field type, you will see a new field created and it is wonderfully and creatively named Field1, and highlighted in black:

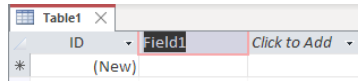

Start typing to rename Field1 to Department. Now, repeat this process seven more times to create the remaining fields. The next field is Status and so forth. Once finished, your table should look like this:

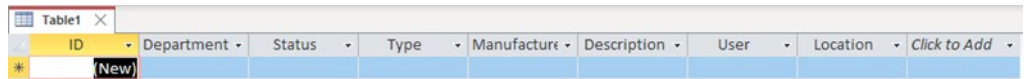

Good work. Go ahead and fill in the collected data now. Left click inside the Department field to start. The selected field will turn yellow, the blinking cursor will appear allowing you to type. Once you fill in a field, you can use the Tab key to quickly move over to the next field.

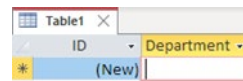

Did you get all the information? Your table should now look like this:

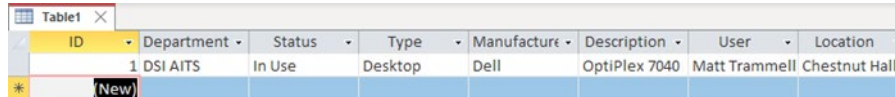

Great, if you look closely at the field names, you can only see part of Manufacturer. To fix that, left click the Manufacturer field to select it. Then right click on the field name and choose Field Width. The following dialog appears:

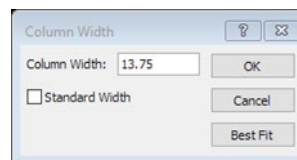

Choose Best Fit. The dialog will close. Alternatively, you can click anywhere within your Access table and move the mouse cursor along the field names until the cursor turns into a cross, typically on the line right before the next field starts. In this case, it would be the line between the Manufacturer and Description fields.

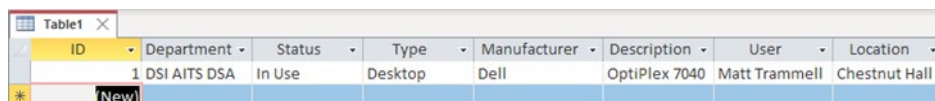

Hooray! Before we close the table and move on, I do want to add two more inventory items. I will create another DSI AITS DSA departmental computer:

ID	Department	Status	Type	Manufacturer
2	DSI AITS DSA	In Use	Laptop	Dell



Markhor.



Description	User	Location
Latitude E7460	Luke Skywalker	Sage Hall

Note: Let Access automatically fill in the ID number for you. It is important that each computer have a unique ID.

Try entering the new computer on your own. I had to fix the field width on both the Description and User fields:

ID	Department	Status	Type	Manufacturer	Description	User	Location
1	DSI AITS DSA	In Use	Desktop	Dell	OptiPlex 7040	Matt Trammell	Chestnut Hall
2	DSI AITS DSA	In Use	Laptop	Dell	Latitude E7460	Luke Skywalker	Sage Hall

Let us add one more DSA AITS DSA departmental computer:

ID	Department	Status	Type	Manufacturer
3	DSI AITS DSA	In Use	Desktop	Dell

Description	User	Location
OptiPlex 7040	Anakin Skywalker	Sage Hall

ID	Department	Status	Type	Manufacturer	Description	User	Location
1	DSI AITS DSA	In Use	Desktop	Dell	OptiPlex 7040	Matt Trammell	Chestnut Hall
2	DSI AITS DSA	In Use	Laptop	Dell	Latitude E7460	Luke Skywalker	Sage Hall
3	DSI AITS DSA	In Use	Desktop	Dell	OptiPlex 7040	Anakin Skywalker	Sage Hall

Once finished entering records, click on the X by the Table1 header. Choose Yes to save changes to the design of table 'Table1':

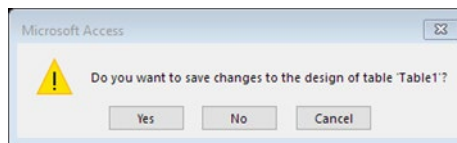

Now we must give our table a name. It is time to enter another wonderfully creative name! Computers! *How original...*

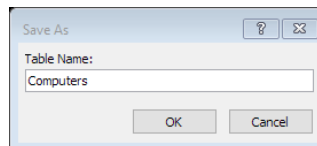

Click OK. Before we move on to forms, I want to mention that it is generally best to limit each field to one piece of information wherever possible. Doing this makes it easier to generate queries and reports, however; the more fields, the more information that the user has to break down and enter, which may frustrate them. Do not frustrate your database users because then, they may not want to use your database! It is all about finding the right balance. How granular do you need to get when collecting your data? For example, I took a shortcut in using DSI AITS DSA as the department name. I probably should break the Department field into three additional fields: Division, Department, and Team. In our case, Division would be DSA, Department would be AITS, and Team would be DSA.

Should you want to make any changes to existing fields or add new ones, you will want to familiarize yourself with the Table Design View. As I designed the sample database for this project, I decided that I did not like the Description field name. I felt that Model more accurately described the information in these fields. To fix that, find the All Access Objects View and under Tables, right click the computers table name and choose Design View. Where it says Description, simply change that to Model. Changing the field name here will also update the field name across queries



Fossa.



and reports! Good deal! Now that we fixed that, close the table by clicking the X. Be sure to agree to save changes! Now we have a clear workspace to move forward!

Note: Anytime that you wish to save your work within Access, click the Save disk icon in the top left of the Access window or press CTRL+S on your keyboard.

Forms

I have shown you how to create tables and how to enter and update information into tables. That is great and all, but you may wonder, suppose I have 10,000 records? How can I ensure that I enter new data or update existing data accurately? This is where forms are extremely useful. I mentioned that Tables are the way to store data in Access. Forms are the way to collect data in Access. Forms help you focus on one record at a time. Forms can help you validate data and enter data correctly into your database.

Let us add a basic data entry / viewing form to our database. Adding a form is really as simple as clicking Create and then clicking Form. Done! Before we move forward, be sure to save your work. Time to name your computers form. Hmm... Insanely Awesome and Easy to Enter or View Computers Form? Nah, but I do like Enter or View Computers. We will go with that!:

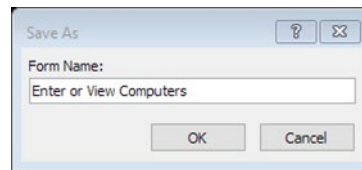

Click OK. Now you have a simple data entry / viewing form:

I also would like to point out the navigational buttons at the bottom of the form:



You can use the arrows to move between the records. The right arrow with a sun burst icon is a quick shortcut to create a new (blank) record. The search area is also very useful to help you find specific records. Perhaps you know the ID number of an item and want to see if you have that item in your inventory? Let us create one more record using the create a new (blank) record button.

The ID field will show (New) and be in black highlighting. We can let Access pick the next available number. Go ahead and press Tab.



Hairy frog.



ID	4
Department	DSI AITS DSA
Status	In Storage
Type	Desktop
Manufacturer	Dell
Model	OptiPlex 9020
User	Matt Trammell
Location	Chestnut Hall

Access will make the **ID 4**. **Department** is still "DSI AITS DSA". Set the **Status** to "In Storage". The **Type** will be set to "Desktop". **Manufacturer** is "Dell". We will set the **Model** to "OptiPlex 9020". I will claim the title as **User** of this PC. "Matt Trammell". Finally, let us set the **Location** to "Chestnut Hall". Done!

As I demonstrated with tables, you can also right click on any one of your forms and choose Design View. Here, you can customize your forms and add or update controls to your heart's content. I did mention a little bit about validation. Unfortunately, any in depth validation, will require some programming knowledge that is beyond the scope of this article. If you are inclined, I do encourage you to research Access Programming to learn about all the cool features that you can implement. However, if you do not have any programming knowledge, you can still help users enter data accurately by giving them a list of choices. The status and location fields are excellent fields to do this for!

If you have not done so already, right click on the form name Enter or View Computers and choose Design View. From within the Design View, left click on the Status text box. It will highlight orange. Right click and choose Change to Combo Box. Once you change that, the height of the status combo box changes from 0.4063" to 0.2493". I do not know why, but it does.

You can change that back though. The Status combo box should remain selected, and you should see a Property Sheet on your right. Select the Format tab and then find Height. Replace the value with 0.4063" and press Enter. Fixed! Now go on over to the Data tab as

Property Sheet

Selection type: Combo Box

Status	
Format	Data
Format	
Decimal Places	Auto
Visible	Yes
Column Count	1
Column Widths	
Column Heads	No
List Rows	16
List Width	Auto
Separator Characters	System Separator
Width	6.8229"
Height	0.2493"
Top	1.1563"
Left	1.2813"

Property Sheet

Selection type: Combo Box

Status	
Format	Data
Control Source	Status
Row Source	...
Row Source Type	Value List
Bound Column	1
Limit To List	No
Allow Value List Edits	Yes
List Items Edit Form	
Inherit Value List	Yes
Show Only Row Source Value	No
Input Mask	
Default Value	"In Use"
Validation Rule	
Validation Text	

pictured above right. Find the Row Source Type and change that to Value List. Now, click within the Row Source field and click on the three ellipses button that pops up (). You should see the dialog on the left appear. I have also entered some suggested values for you - In Use and In Storage. I set the default value to In Use.

Your Edit List Items should look something like below. Put a valid status each on its own line. Choose a default value so that the field is not blank.

Once you are happy with your value list, click on OK. You can take the same approach for the location text box, but I will let you have fun with that on your own!



Okapi.



If you do not see the property sheet, you may need to toggle the view. Within the form's design view, ensure that property sheet is selected in the Tools ribbon:

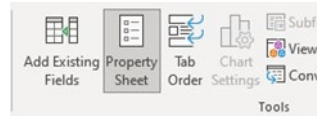

As I stated in the beginning, I could have gone into much more detail and written several more pages. However, my goal in this article was to give you an overview of Access tables and forms. Stay tuned for my Intro to Access Databases Part II on queries and reports. As always, if something interests you, feel free to do some research. There are plenty of Access database resources online!

Until next time!



Sea pig.



What's Your Reality?

[Christopher Horiates, Senior IT Support Manager]

It seemed the next big up and coming tech item was some form of reality; Virtual, Augmented or Mixed. Technology in those fields was very much ramping up and it seemed we were on the verge of some heavy competition from lots of large tech companies. Then March 2020 came around, time froze and the momentum these technologies had gained seemed to fizzle. Oddly enough had we been able to adopt and get pricing down ahead of 2020, these technologies would have helped keep us connect in ways we would have benefited from seeing as we went to a remote distant world.

With things getting back to whatever our new normal is going to be, I hope to see a rise in use of some form of Reality Technology. As I stated above there are three types of this technology. Virtual, Augmented and Mixed being a combination of both. Each have their strengths, weakness and use cases.

Some of the big names in both spaces are Microsoft, Sony, Samsung, Meta (Facebook) and Google. All have a different approach and ultimately, they accomplish the same thing, just depends on your price point and what you want from it. Personally, prior to the pandemic, I was able to try out various products and all kinds of the technology.

Virtual Reality (VR) - is a simulated experience that can be similar to or completely different from the real world.

Augmented Reality (AR) - is an interactive experience of a real-world environment where the objects that reside in the real world are enhanced by computer-generated perceptual information, sometimes across multiple sensory modalities, including visual, auditory, haptic, somatosensory and olfactory.

Mixed Reality (MR) - a blend of physical and digital worlds, unlocking natural and intuitive 3D human, computer, and environmental interactions.

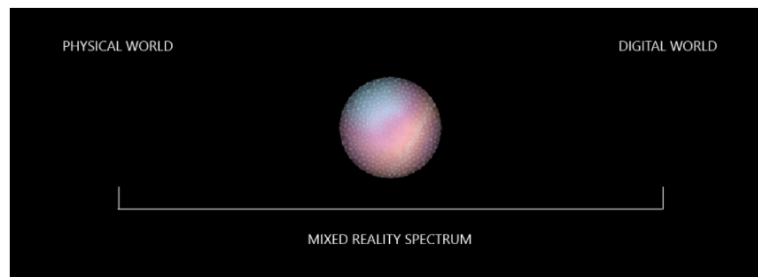

Source: [What is mixed reality? - Mixed Reality | Microsoft Docs](#)

VR is what most people are familiar with. If you have spent any time at a Main Event, or some sort of arcade place, you most likely have seen a VR headset with some sort of game. While the technology from the late 90's in terms of graphics has vastly improved, the concept is still the same. You put on a headset and get immersed into a virtual world. Still to this day you are attached to a computer of some kind that drives the content into the head unit. I know people who have cutting edge VR units, with basically 4K screens in them, and when they play PC Games like the new Flight Simulator, they say it's as close to being on a plane without being on one. This type of setup is for gamers and perhaps classroom instruction or medical reasons like overcoming some sort of fear.



MR, while not necessarily new, is just now catching up to where it can become something attainable and useable. The big hang up with MR is the field of view (FOV) and while the size has grown, it's not fully immersive like a VR unit. Of course, with MR you are blending the real world with holograms, but if you are only able to see said holograms in a small FOV it loses its luster. People want the full FOV to where out of any angle your eyes see the AR world holograms, and such are seeable. We are getting to this point but still have some technical issues to



Blue viper.



overcome. Microsoft HoloLens, while one report says it's on its way out and Microsoft says otherwise, was and still is in my opinion the leader in this realm currently. Companies and industries have adopted and developed on this platform and use it in real world scenarios.

Characteristic	Holographic devices	Immersive devices
Example device	Microsoft HoloLens 	Samsung HMD Odyssey+ 
Display	See-through display. Allows the user to see the physical environment while wearing the headset.	Opaque display. Blocks out the physical environment while wearing the headset.
Movement	Full six-degrees-of-freedom movement, both rotation and translation.	Full six-degrees-of-freedom movement, both rotation and translation.

Source: [What is mixed reality? - Mixed Reality | Microsoft Docs](#)

AR has been around for a while and encompasses more than just technology covering your eyes. It can also be as basic as using the Amazon Shopping app to see if that new TV you want to buy will fit by using your camera on your phone, measuring the room and placing a hologram of a TV in your home. Or it could be for entertainment. I remember at Six Flags there was a plane ride indoors that the seats would move as if you were flying. Now it has been replaced with another indoor ride that uses 3D glasses, noise, lights, motion, heat, and interactive game play with guns. This is a great example of AR. Newer versions of this would be Star Wars attractions at Disney World. They are cutting edge and very immersive. AR requires lots of technology to be fully immersive and to augment the real world or can be as simple as a cell phone as mentioned above.

Going forward these three types of technologies will improve, become more mainstream and be accepted in some, but not all circles. While I can personally appreciate the technology and what it can do and the use cases, I am afraid this will continue to drive the distance we as humans have done with the internet and cell phones and other technology have come to grow comfortable with. Meeting and talking to a person face to face, holding hands, hugging, seeing raw emotion or simply feeling a gentle cool breeze will never be replaced by any type of technology. No matter how hard we try we can never get there. We are social creatures who need a true reality of life, fresh sunshine, emotions and just living our life for the short amount of time we have to its fullest. We are not meant to be plugged in and staring at screens all day. To that I say just choose reality and every now and then mix it up with some form of technology in small doses.

 **Marabou
stork.**



Wordle Bot

[Derek Boyd, Cross-Functional IT Support Supervisor]

You may have heard about Wordle already, but if you haven't, Wordle is an [online word game](#) where once a day, players get six chances to guess a five-letter word. Once you submit a guess you get feedback from the game, telling you which letters are in the daily solution and which are not. For most people, a few minutes of brain

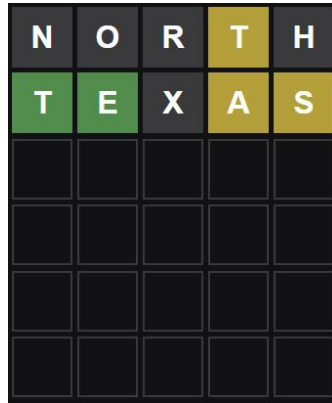

teaser is enough time spent with Wordle. But some programmers have taken it a step further and developed bots to solve the word game in the least possible guesses. As with many people who write scripts or code, should they spend a few minutes solving a simple word game or instead, spend days developing a program and algorithm that will solve it faster? Of course, the answer is the latter.

The game was created by a software engineer named Josh Wardle. His partner loved word games like the New York Times Spelling Bee and the Daily Crossword. So, he decided to create a word game that they could both play. The game's name, Wordle, is a play on Mr. Wardle's last name. When creating the game, Wardle

added a list of about 13,000 five-letter words as valid guesses. But since many of the words on the list were pretty uncommon, Mr. Wardle's partner helped him curate the list down to about 2,300 more common words as the daily answers. The 13,000 words are still valid guesses in the game. Matter of fact, you can view both word lists in the source code. You can do this by going to the [Wordle](#) site > **press F12 > Sources tab > games/wordle folder > main.js file**. Also, the 2,300-answer list is in order of daily appearance. So, you could look up the next day's answer, if you wanted to. Using these readily available word lists, programmers were able to create programs and algorithms to solve the word game faster and more efficiently.

Programmers [Grant Sanderson](#) and [Jonathan Nolson](#) created their own apps to solve Wordle using information theory and entropy. Both programmers, in their separate projects, decided to use the full 13,000-word list, instead of the 2,300-word list, so that their programs would be more resilient to future changes. The first thing they needed their bot to determine is what words, on average, give the most information and quantify that information. The programmers turned to entropy information theory to solve this problem and develop their algorithms. Entropy, in information theory, is the average level of information and uncertainty that is inherent to a variable's possible outcomes. In other words, if something has a low probability to happen, but does occur, that is highly informative. If something happens, that is expected, it's not very informative. For example, knowing lottery numbers that won't win is highly probable and not informative. However, if you knew the lottery number that would win, that is highly informative because it communicates the outcome of an event that has low probability. In Wordle, the word 'xylyl' (a valid Wordle guess) is highly probably to have a resultant output of all grey tiles or maybe one yellow tile. It is much less likely that you get all green tiles or mostly green tiles. But if you did, it would be highly informative. Using these patterns and entropy formulas, the programmers were able to determine which words and their respective output patterns, on average, would be the most informative. Next, they weighted the words in the 13,000-word list by which are the most common. So, in the first couple of guesses, the bot will try to gather the most information possible and pare down the list of possible outcomes. Once it gets to the third or fourth guess, it will then include the weighted value of each word and choose more common words. Humans on average can solve Wordle in four guesses. Solving it in three can be difficult. The bot can solve it, on average, in three guesses. However, there isn't enough information available for the bot after two guesses to always guess it in three.

So, what did the programmers find? The best words to start with in Wordle, for the bot, are: salet, reast, crate, trace, slate, crane. You'll notice that crate and trace have the same letters. The order of letter appearance did have value and give more



Blue whale.



information to the bot. For a human, these words can be a good starting point, but the catch is, we won't be able to determine the next best guess like the bot can. For humans, words that knock out a lot of vowels may be more useful. Some examples are adieu, audio, louie, and ouija. If you'd like to learn more about the programs and the algorithms used, you can visit Jonathan Nolson's [WordleSolver](#) to see a working model of the bot. You can also visit Grant Sanderson's [YouTube](#) videos which discuss entropy information theory.



Hippopotamus.



Teens and Technology, the Benefits (yes there really are benefits)

[Jennifer Lee, Sr. Cross-Functional IT Support Specialist]

Parents, teachers and others who work with teenagers on a regular basis have in one fashion or another, had a love/hate relationship with teens and technology. This has been even more apparent during the pandemic we are still dealing with now. However, it is the same pandemic that has become responsible for illuminating the benefits of tech for teens.

The first and most obvious of these benefits is that not only teens, but students of all ages have been able to continue their education. While not always the best learning environment for everyone, tech allowed classes to continue regardless and therefore benefitted teens.

Next and perhaps the most controversial is social media. While the apps that commonly come to mind initially include Insta, Snap, TikTok, etc., There are also other points of access such as Discord, Twitch, Mumble and Steam. While the latter are generally considered chat apps used mainly by the gaming community, many platforms also include streaming, vid chat, etc. that allows entire communities to evolve around popular topics/games. These methods of communication have allowed teens to maintain social connections in a world that currently frowns upon in person meetups.

Finally, technology has allowed Teens have access to an incredible amount of information. Of course, this has caveats, but pretty much everything does in some fashion. This has, in my opinion, closed the generation gap when it comes to understanding 'the good old days' in a way that older generations weren't able to. Genealogy to The Oregon Trail, there remains tangible and interactive examples can be found at the click of a mouse.

While the technologies here are far from the be all end all of benefits of tech for teens, It is a good example of looking at the benefits instead of just the drawbacks of a thing.



Puss moth caterpillar.



Ideas – New Feature of Power Apps – Good or Evil?

[Sharon Huang, University Web Developer/Programmer]

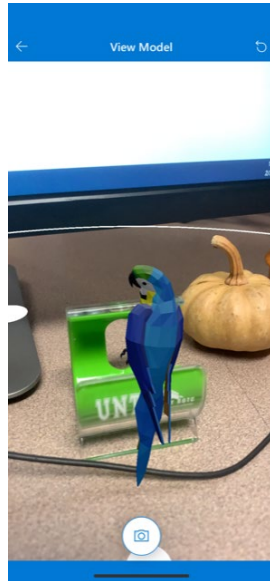

In my last article, I covered the “new” feature of Power Apps - Mixed Reality (MR): [Click this link to see my demo MR project](#). You need a “newer” phone to use MR (iPhone 10 or later). Check the details from my previous article, or simply try and see if it works on your phone. You can choose a 3D object I provided (for example, the bird), then put it anywhere in your real-world environment, like your desk or your friend’s head! ☺

In this article, I am going to cover another new feature of Power Apps - Ideas. Microsoft just published an article on Ideas yesterday, Feb 15th, 2022.

When you create a project on Power Apps, you will need to use an Excel-like formula to build certain functions. That Excel-like formula is called Microsoft Power Fx, an open-source programming language for low code apps creation. Not everyone is familiar with the formulas; it may take a great amount of time to search for a proper formula from the formula reference and learn to use it.

So, Ideas was created to help new users with formulas by generating the formula for you! Novice Power Apps users save time learning, and experienced user also benefit by saving the time it would take to manually type out formulas. Ideas uses the power of AI models to detect what you want to do and creates the complete formula for you.

When I first tried this, I said “Nice, it saves me the effort of typing!” Actually, when you type a formula, Power Apps is smart enough to auto-complete your formulas, bringing up what you wanted to type while you’re typing, just like many object-oriented programming languages do. Ideas just make us lazier. Well, it’s not bad to be able to do less and achieve the same task. I like Power Apps’ nature of improving its features all the time, like adding MR (Mixed Reality), AI (Artificial Intelligent), Chabot, and more! With the combination of Power Automate (Flows), and huge connections to other software and APIs, you can create about anything!

That’s enough praise for Power Apps. It’s a great piece of software, and it is from Microsoft, so I am sure you can find more complements on the internet about how powerful it is. So, what led me to put the heading, “Good or Evil?” on this article about the new Power Apps feature - Ideas?

When I first tried Ideas, I said “nice” and remembered the time I first got my hands on Power Apps. I looked through documentation, searched and debug formulas, and realized it’s now easy and fast, a no brainer. No brainer? Yes, that’s why I think it’s not so good anymore!

Do we really want to be that lazy? How many of you can remember your friend’s phone number now after having cell phones? How many of you rely on auto-correct in Word to help you write like I am doing now? How many of you never double check your shopping receipt because it is automatically calculated? And soon, we will not have to drive; a self-driving car is going to drive for us. On and on, we love the technologies, but I don’t know if I really want my memorizing skills, spelling skill, number-sense skill, driving skill and more skills to fade away.

There are always people taking a negative view for technologies, and we as computer professionals often have more positive views. But no matter what your view is on new technologies, this is a path of no return. We have it and we will use it for sure. So, no more complaints; let me introduce to you the newest feature of Power Apps - Ideas.



Pievine swallowtail caterpillar.



How to

To use Power Apps Ideas, you'll find an Ideas pane on the right side of your canvas app, next to **Properties** and **Advanced** tabs. Or you can simply right click the mouse on your apps design screen; it's available on your fingertips. However, Ideas is available only on new apps you create now. It's not available on the apps you created before they put out this new feature.

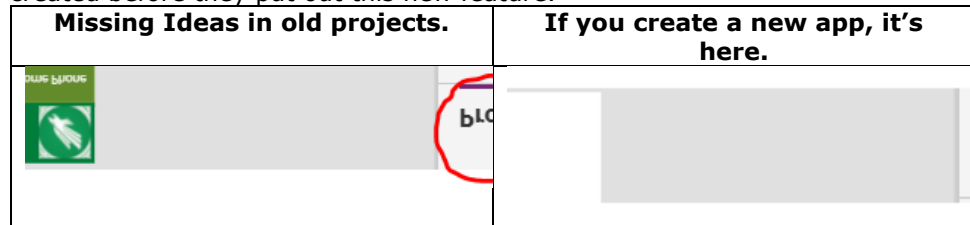

There are two ways to use Ideas:

I. Transform natural language to Power Fx formulas

1. You need to have a gallery which is connected to a data table.

2. Click on the "Ideas" tab and type in what you want to do in the box. As you type, the proper column name will show, so there's no need to remember the exact column name. After you typed in the column name, click on "Get ideas".

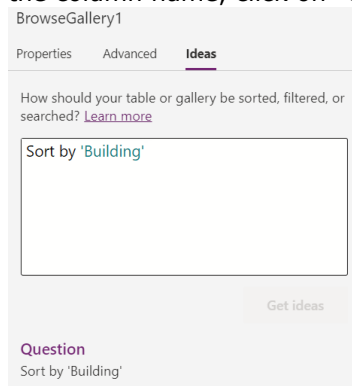

3. Click on Apply, then edit if necessary.

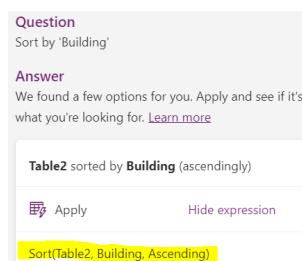

For example, change Ascending to Descending in your formula bar here.

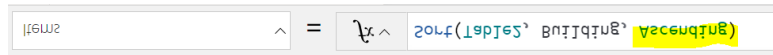

Yes, it's that easy. And you can send Microsoft feedback at the bottom of the screen if the generated formula is not what you want, or you have some other suggestions. I sent in the following feedback: "Can you provide an oral input function through a microphone icon to save typing?" Let us see if I will get this function or get some feedback from them. The company will create more AI for more formulas and more languages, so I don't need to ask for more languages; it's in their agenda already. So, maybe in the near future, we can speak in Chinese and the formula will appear for you to apply.

II. Transform examples to Power Fx formulas

 Hickory
horned devil
caterpillar.





Spiny flower mantis.



Train with examples uses PROSE (Programming by Examples and Natural Language) so you can just provide a desired output example, then Power Apps will generate the formula for you.

For example, you want to change Date/Time format from "9/14/2013 7:00 PM" to "September 14th, 2013". Simply (1) select one date field (the field content "9/14/2013 7:00 PM" will show up in Ideas input box), (2) edit it to the format you want ("September 14th, 2013"), then (3) click on "Get ideas". You will see the resulting formula at the bottom. Just click "Apply", and it will change your formula right away. It's that easy!

The screenshots illustrate the workflow of the 'Ideas' feature. It starts with a user selecting a date field in a form. The 'Ideas' panel then provides an example of the desired format. The system generates a formula based on this example, which the user can then apply to their data.

Conclusion

I am glad Microsoft continues to develop features for Power Apps, and it is indeed a very powerful tool. Even though I don't think "Ideas" is that big of an idea compared to MR and other new features, it does make the developer's job much easier.

By the way, I once did a form project for a department. One of their concerns is about the "signature" field type not being available in Power Apps. Yes, you guessed it right - it's now available as "ink input" in Power Apps! It allows user to sign their name by finger writing.

Now, my biggest worry about this great tool is money. Yes, we have it for free from Office 365, with limited functions. We can create AI projects but need a paid license to use the AI projects. We can create our own environment, but the environment will be deleted after a period of time because of the free license. Who knows when Microsoft will impose more limitations for the free version, like not being able to

publish your projects? And then UNT might need to pay lots of money to keep the projects we've already built and used, or make us build the projects again in another environment. Well, this is not my concern actually, it's the UNT decision makers' concern.

Reference Links

- **Microsoft Power Fx** – <https://docs.microsoft.com/en-us/power-platform/power-fx/overview>
- **Power Apps Ideas (preview)** – <https://docs.microsoft.com/en-us/powerapps/maker/canvas-apps/power-apps-ideas>
 - [Transform natural language to Power Fx formulas](https://docs.microsoft.com/en-us/powerapps/maker/canvas-apps/power-apps-ideas-transform) – <https://docs.microsoft.com/en-us/powerapps/maker/canvas-apps/power-apps-ideas-transform>
 - [Transform examples to Power Fx formulas](https://docs.microsoft.com/en-us/powerapps/maker/canvas-apps/power-apps-ideas-train-examples) – <https://docs.microsoft.com/en-us/powerapps/maker/canvas-apps/power-apps-ideas-train-examples>
 - [Formula reference](https://docs.microsoft.com/en-us/powerapps/maker/canvas-apps/formula-reference) – <https://docs.microsoft.com/en-us/powerapps/maker/canvas-apps/formula-reference>
 - [My demo MR project](#)



Scorpion fly.



One Code To Bring Them All: A (Brief) Introduction to Unicode

[Evan McWhorter, Dr. Cross-Functional IT Specialist]

Picture these:

It's the 1700s, you work as a printer for a local newspaper, and you're very happy with your job. Every day people bring you news articles they have written, you've gotten quite quick at transcribing those articles with your boxes of movable type, and everyone's very impressed with your skill. One day, however, someone brings you a news article about Russia, and all of the names of the places have been written in Cyrillic. You don't have all of the letters you need to spell words like друг or товарищ, and receive several angry letters (this is far too early for telegrams) when you just substitute in letters you think looked close enough.

It's the 1980s, and you want to send an email to your pen pal in Switzerland. You send them an email in English, since they're learning English, and they send you back an email in Swiss German, since you're learning Swiss German. However, every email they send you looks less like "Könne Sie Schwitserdütsch reede?" and more like "K|nne Sie Schwitserd}tsch reede?". Frustrated, you slowly give up on your dreams of learning Swiss German on your computer, and vow instead some day to just visit Switzerland and your friend instead.

It's 2021, and you work as an editor for a news website. One of your writers sends you an article they have written about Russia, and all of the names of the places have been written in Cyrillic. You give it a brief once over for mistakes and inaccuracies before deciding it's good, and you post it publicly.

Some time within the last 30 years or so, a problem endemic to movable type within a more global community was encountered, considered, and fairly thoroughly worked around in such a way that the average user, beyond occasional annoyances at emojis not showing up right on some devices, would not even have to consider it to reap its rewards. The workaround, considered and developed initially by about 13 people, was called Unicode.

In the very early days of computing, there was next to no standardization for how data was stored and handled; at that point, there didn't really need to be. When just starting out, computers weren't really talking to each other very much and were quite like rather large calculators. However, as computers became more and more common, their users needed a way to move data from one to another. Something needed to be done to standardize how data about text was stored on computers so that they could more easily communicate with each other, and after much hemming and hawing the American National Standards Institute, or ANSI, took about 2 years to develop a consistent 7 bit code for encoding data which they called ASCII. However, during those 2 years one of the largest manufacturers, IBM, used their own system called EBCDIC that would stick around for about 20 years, keeping ASCII from as widespread use as was needed.

During this time, most development of computer technology was happening in the United States, and almost all was happening in places where the Latin script was used. However, having English as the default language and the basic Latin script encoding all text data was, for obvious reasons, unreasonable. For a while, this was worked around by adding an eighth bit to character encodings, effectively doubling the number of working characters. However, you still had to make sure whoever was on the other end could understand that format, and, to make matters worse, you also had to specify which code page to look up the extra characters on to make



Antlion.



 Goliath
Beetle.



sure you were sending them right; what one person in Estonia uses as a ÿ might be a ¾ in Britain! (And woe betide those who receive 8-bit encoded text on a 7-bit system!) Clearly, this wasn't working, and something had to be done.

In 1988, Joe Becker from Xerox, with input and help from 4 other people, published a proposal for a universal character encoding system that he called Unicode. By using 16 bit text encoding, he reasoned, he could have well over 16,384 characters in a single set - more than enough to encompass the characters of all the world's living languages. By the end of 1991, with the addition of about 8 more people, a nonprofit consortium had been incorporated and had published the first volume of the Unicode Standard.

30 years on, a lot has changed about Unicode. In 1996, additional encoding was added allowing more than 16 bits per character and opening up over 1,000,000 new characters to be included in its character set. Over time, Unicode has gone from just encompassing living scripts to implementing dead ones, too. During the process of adding support for various scripts, the Unicode Consortium also took care to add support for every local text data encoding they could find - most notably, when adding support for existing Japanese text, they included the small representative pictographs (called Emoji) that were in some of the otherwise unused parts of the character set.

Is Unicode perfect? Not even close. Writing systems for constructed languages, slight variations for personal preference for writing on paper, and even some widely used symbols such as the Dutch krul, used for flourishes of approval, are all currently impossible using Unicode. However, according to the Unicode Consortium 2020 tax forms, they have 3 employees working for them, and they still manage to release a new version of Unicode at least once a year since 2014. They have support for scripts I've never heard of, have support for scripts I use daily, and have standardized data storage to such a degree that I could send from my phone to an email halfway across the globe a small picture of a man in a business suit hovering and would know without a doubt that the person on the other end will understand it as a man in a business suit hovering. They have fairly tidily solved a core problem of computer networking so well that most people now don't even notice the problem exists at all, and for that I think I can forgive them not doing the impossible. And if you really need a script that Unicode doesn't encode, they have included permanently blank sections for you to add your own!

--Evan

--Еван

--ᲞᲠᲢ

--エーバン

--🧑[▶️🏹📍🚶👉🔧🧑📢📖]

What is the US Space Force?

[Colton Estes, Sr. Cross-Functional IT Specialist]

Many people have probably heard of the US Space Force (USSF) by now, but many aren't sure what it means or what the newest branch of the military does. Wait, that really exists? When/Will you be going to space? How is it different from NASA? These are some of the more common questions I get when I tell someone I'm going into the USSF.

Let's get some of the easy questions out of the way first. First, yes, the USSF exists as the sixth branch of the US Armed Forces, under the Department of the Air Force. You can think of this being similar to how the Marines are a separate military branch but under the Department of the Navy. Second, most likely in the current time USSF personnel, called Guardians, will not be going into space. Instead, broadly put, Guardians protect and maintain our military assets in space from the ground. This is where the USSF differs from NASA. NASA is largely focused on the science, research, and exploration that comes with the space domain, whereas the Space Force focuses on the military outlook on space to protect our nation and support our infrastructure in space. GPS is an easy example to demonstrate, if you've used GPS before, then you've used the technology and infrastructure that the USSF supports and maintains.

Those are more surface level facts and questions, and generally suffice most people with what they want to know. However, some people ask deeper questions, such as "Why do we need a Space Force? Don't they just do what the Air Force was already doing?" In a way, yes. Many of the service members that were carrying out space operations as part of the Air Force are continuing to do so now as part of the Space Force. However, the difference lies in that the Space Force is now independent from the Air Force and has the ability to set independent goals, policies, and financial requests that would have previously come through the Air Force which has its own priorities. This allows the USSF to stay competitive in the space domain because it isn't dependent on the Air Force to allocate funding to the space mission when the Air Force is really focused on staying competitive in the air through new aircraft. The Space Force is also transferring over personnel from other branches of the military (Army, Navy, and Marines) to bring together a pool of experiences and capabilities that will enable better communication and cooperation between branches in space operations. This will also help the USSF form its own distinctive culture as personnel combine into the new branch that allows the creation of a forward-thinking and innovative culture to combat new threats in the space domain.

Hopefully you now have a little bit better of an understanding of what the US Space Force is and why it exists. By the time this article comes out I will be settled into my first duty station learning my job as a young new officer. So, I want to thank everyone I've worked with for being amazing, and I wish you all the best in your current and future careers.



**Brazilian
Treehopper.**



Solution to last newsletter's brainteaser

If I am a prime number less than 100. If you add my two digits and multiply me by the number that results from it, you get the same number as the number of weeks in a year. What number am I?

Answer - 13. Prime numbers 1 & 3. Added together we get 4. $13 \times 4 = 52$ for 52 weeks in a year.