

NOTES, UNLESS OTHERWISE SPECIFIED:
 1. FOR REFERENCE ONLY.

REV.	DESCRIPTION	DATE	APPROVED
A	INITIAL RELEASE	7/11/2024	J. BEVERAGE

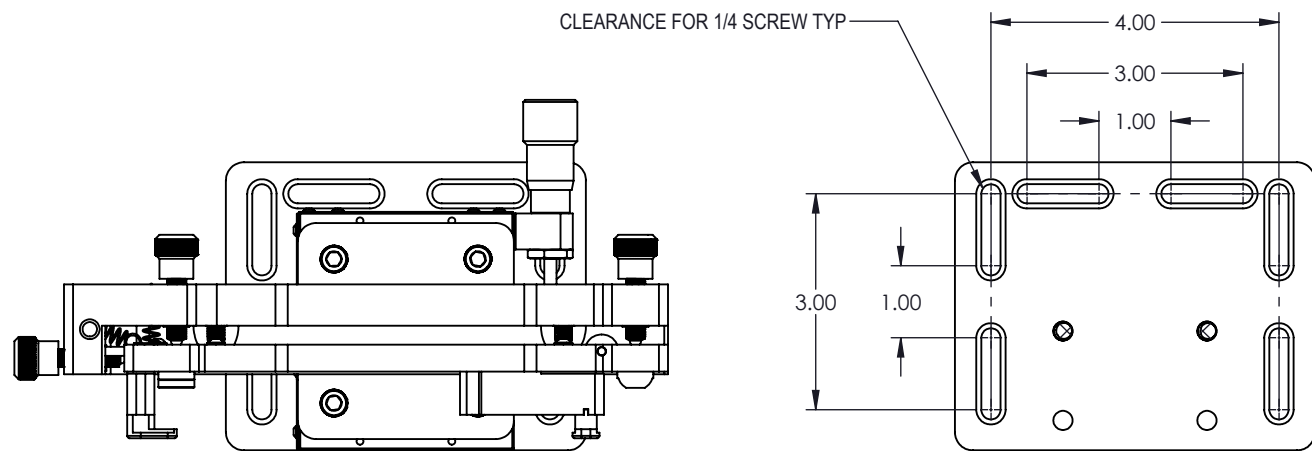

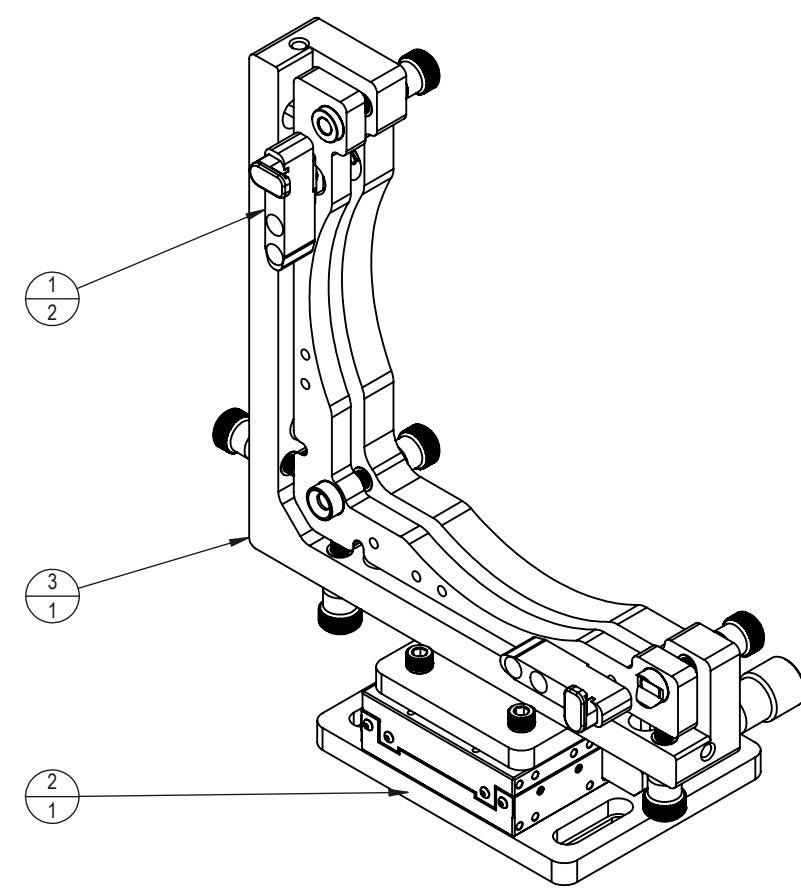

SECTION A-A

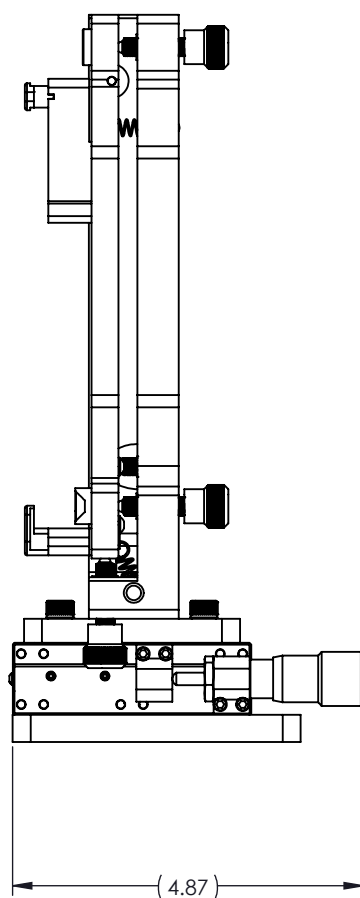
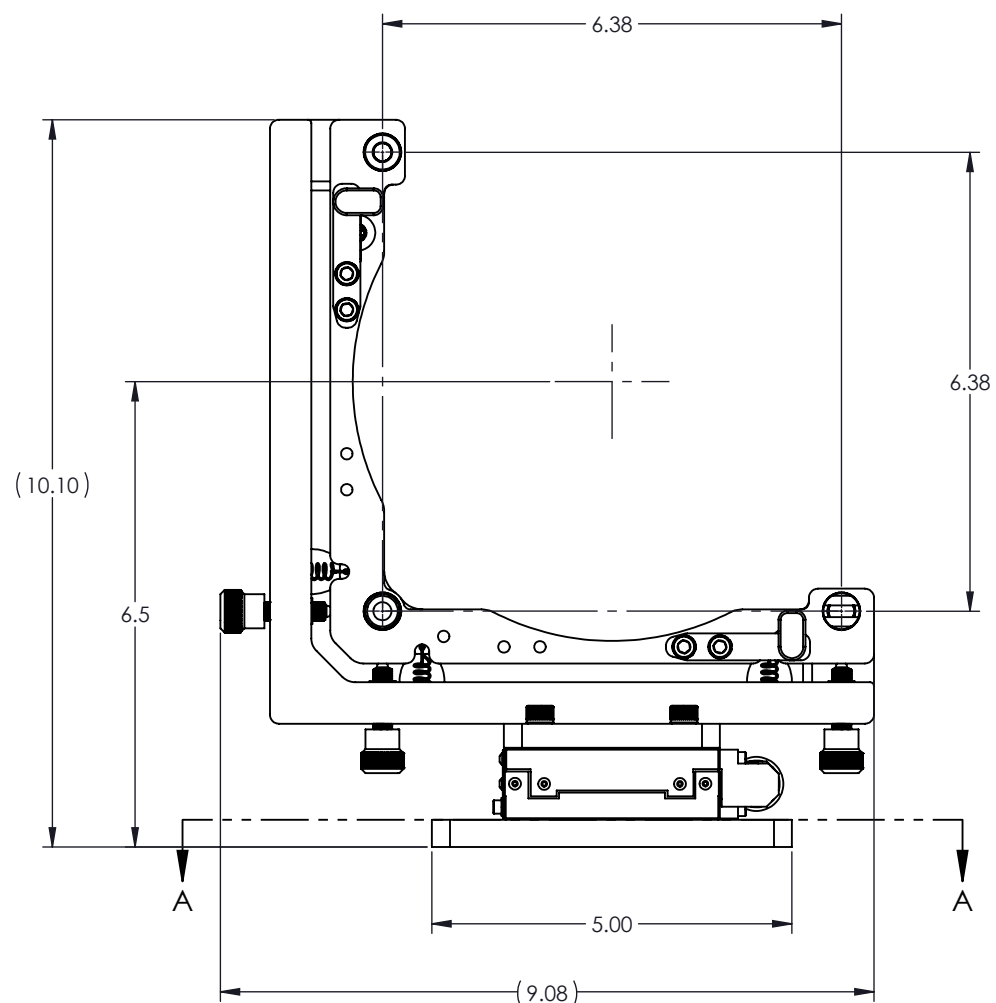

ISO VIEW
SCALE: N/A



ITEM NO.	QTY.	PART NUMBER	DESCRIPTION
1	2	20-00077	ASSY, CLAMP, CANTILEVERED
2	1	20-00095	KIT, BASE, FP3-Z, 4 1/4 CL
3	1	20-00121	ASSY, STAGE, 6 3/8 X 12MM

THIS DOCUMENT CONTAINS INFORMATION WHICH IS PROPRIETARY TO ARIZONA OPTICAL METROLOGY. NO REPRODUCTION OR PUBLICATION OF THIS DOCUMENT, IN WHOLE OR IN PART, SHALL BE MADE WITHOUT WRITTEN AUTHORIZATION FROM ARIZONA OPTICAL METROLOGY.	TOLERANCES PLACES IN DIMENSION .X .XX .XXX DIMENSIONS ±.05 ±.01 ±.005 ANGLES ±.5° FRACTIONS ±1/32			 ARIZONA OPTICAL METROLOGY 2420 W Ruthrauff Rd #160 TUCSON, AZ 85705 Phone: 520-833-5761 Email: info@CGHnulls.com
	MATERIAL: N/A HEAT TREAT: N/A FINISH: N/A			
UNLESS OTHERWISE SPECIFIED: ALL DIMENSIONS ARE IN INCHES AND APPLY AFTER COATING/PLATING.	TITLE 6-DOF C6 FINE POSITIONING STAGE, 6.5" CL			
DRAWING STANDARD PER: ASME Y14.5-2009 INTERPRET WELDING SYMBOLS PER AWS A2.4	DESIGN BY: T. GROSS	DATE: 7/2/2024	SIZE B DWG NO. FP6-Z-H650 REV. A	
REMOVE ALL BURRS AND EDGE BREAK .01" MAXIMUM	DRAWN BY: T. GROSS	DATE: 7/2/2024	SCALE 3:8 WEIGHT 4.4 LBS SHEET 1 OF 1	
 DO NOT SCALE DRAWING	CHECKED BY: A. CLARK	DATE: 7/11/2024		