

## **Effector Triggered Immunity: NLR Immune Perception and Downstream Defense Responses**

Authors: Chiang, Yi-Hsuan, and Coaker, Gitta

Source: The Arabidopsis Book, 2015(13)

Published By: The American Society of Plant Biologists

URL: <https://doi.org/10.1199/tab.0183>

---

BioOne Complete ([complete.BioOne.org](https://complete.BioOne.org)) is a full-text database of 200 subscribed and open-access titles in the biological, ecological, and environmental sciences published by nonprofit societies, associations, museums, institutions, and presses.

Your use of this PDF, the BioOne Complete website, and all posted and associated content indicates your acceptance of BioOne's Terms of Use, available at [www.bioone.org/terms-of-use](https://www.bioone.org/terms-of-use).

Usage of BioOne Complete content is strictly limited to personal, educational, and non - commercial use. Commercial inquiries or rights and permissions requests should be directed to the individual publisher as copyright holder.

---

BioOne sees sustainable scholarly publishing as an inherently collaborative enterprise connecting authors, nonprofit publishers, academic institutions, research libraries, and research funders in the common goal of maximizing access to critical research.

First published on October 28, 2015: e0183. doi: 10.1199/tab.0183

# Effector Triggered Immunity: NLR Immune Perception and Downstream Defense Responses

Yi-Hsuan Chiang<sup>a</sup> and Gitta Coaker<sup>a,1</sup>

<sup>a</sup>Department of Plant Pathology, University of California Davis, Davis California, 95616

<sup>1</sup>Address correspondence to glcoaker@ucdavis.edu

Plants have evolved sophisticated surveillance systems to recognize conserved microbial patterns or secreted pathogen effector proteins. Research in *Arabidopsis* has significantly advanced our understanding of plant immune perception and signaling. Intracellular immune receptors possessing central nucleotide binding and C-terminal leucine rich repeat domains (NLR) recognize pathogen effector proteins delivered inside host cells during infection. Characterized NLRs can either directly or indirectly recognize corresponding pathogen effector proteins. Despite the conserved domain architecture of NLRs, no unified model exists for induction of downstream signaling. NLRs have diverse subcellular localizations, including targeting to the endoplasmic reticulum, plasma membrane, nucleus, and cytosol. This review will focus on our current understanding of NLR biology, from signal perception to downstream immune outputs.

## INTRODUCTION

Plants possess a multi-layered immune system that can be distinguished based on the domain architecture and subcellular localization of immune receptors. Receptor-like kinases and receptor-like proteins possess extracellular domains and are involved in the perception of conserved microbial features, called pathogen- or microbe-associated molecular patterns (PAMPs/MAMPs) or apoplastic pathogen effector proteins (Zipfel, 2014). The perception of conserved microbial features, such as bacterial flagellin or fungal chitin, culminates in pattern-triggered immunity (PTI) (Zipfel, 2014). Intracellular immune receptors, typically possessing central nucleotide binding and C-terminal leucine rich repeat domains (NLRs) recognize pathogen effector proteins delivered into plant cells during infection culminating in effector-triggered immunity (ETI) (Elmore et al., 2011). There are a significant number of immune receptor loci in plant genomes, with the *Arabidopsis* genome possessing over 600 receptor-like kinases and ~150 NLRs (Meyers et al., 2003; Johnson and Ingram, 2005). Furthermore, *Arabidopsis* has served as an important model system that has shaped the understanding of plant immune signaling, facilitating the cloning of some of the first NLR immune receptors as well as identification and characterization of important immune signaling components.

Plant NLRs can be subdivided into two main classes that influence downstream signaling pathways based on their N-terminus possessing a Toll/Interleukin-1 receptor-like (TIR) region or coiled-coil (CC) region (Elmore et al., 2011) (Figure 1). NLRs with

TIR domains are also termed TNLs (TIR domain, nucleotide binding, leucine rich repeat); NLRs with CC domains are also termed CNLs (CC domain, nucleotide binding, leucine rich repeat). CNLs generally require the GPI anchored protein NON-RACE SPECIFIC DISEASE RESISTANCE 1 (NDR1: AT3G20600) for signaling (Century et al., 1995). On the other hand, multiple TNLs require ENHANCED DISEASE SUCCEPTIBILITY 1 (EDS1: AT3G48090) and PHYTOALEXIN DEFICIENT 4 (PAD4: AT3G52430) for signaling (Parker et al., 1996). NLRs are found in early plant lineages and some plant species exhibit significant NLR gene expansion. It is interesting to note that TNLs are absent in several plant species including monocots, whereas CNLs are found in both monocots and dicots (Yue et al., 2012).

Despite significant differences in localization and genetic loci required for full immunity, common cellular changes occurring during ETI are prevalent. NLR activation induces Ca<sup>2+</sup> signaling, sustained reactive oxygen species (ROS), alterations in membrane trafficking, and global transcriptional reprogramming to induce strong defense responses (Spoel and Dong, 2012). In addition, a hallmark of ETI is the hypersensitive response (HR), a form of programmed cell death at the site of infection. Although activation of PTI can also induce an HR (Naito et al., 2007), the HR is most commonly associated with NLR activation. Despite the prevalence of the HR during ETI, genetic mutations in loci such as *DEFENSE NO DEATH-1* (*DND1*: AT5G15410) and *ARABIDOPSIS THALIANA METACASPASE 1* (*AtMC1*: AT1G02170) can uncouple HR and resistance, indicating that the HR may be

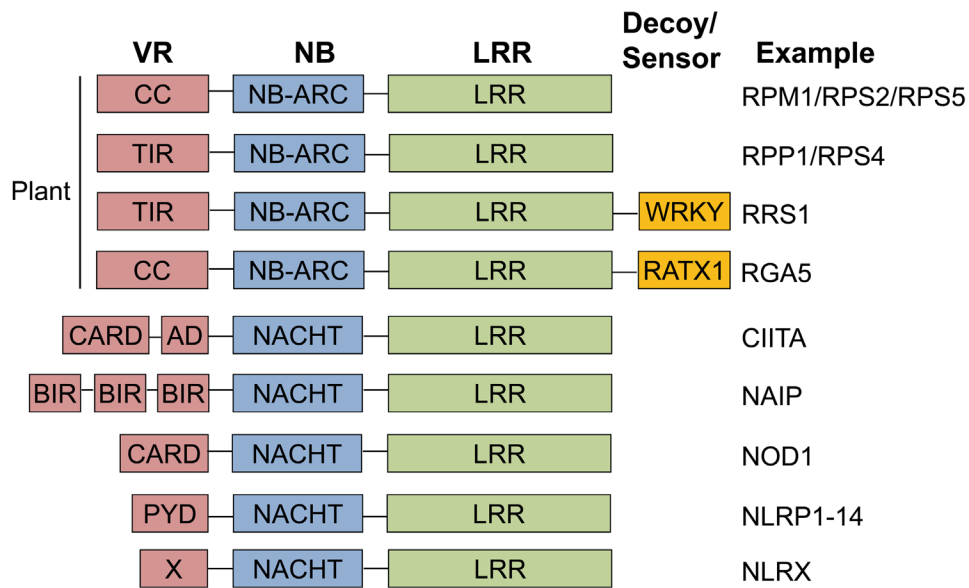

**Figure 1.** NLR Domain Architecture.

Similarity across plant and animal NLRs. Examples of NLRs exhibiting the depicted domain architecture are shown to the right of each diagram. VR = variable region, NB = nucleotide binding, NB-ARC = nucleotide-binding adaptor shared by APAF-1, R proteins, and CED-4, NACHT = nucleotide binding domain present in animal NLRs, LRR = leucine rich repeat. The NACHT nomenclature is derived from four plant and animal proteins that initially comprised the features of this domain.

a consequence rather than a cause of resistance (Clough et al., 2000; Coll et al., 2010).

### NLR DOMAIN ARCHITECTURE AND NUCLEOTIDE BINDING

The central region of NLRs consists of the NB-ARC (nucleotide-binding adaptor shared by APAF-1, R proteins, and CED-4) region (Figure 1). The NB-ARC domain comprises motifs that are hypothesized to control nucleotide binding (Walker A/P-loop/MHD) and hydrolysis (Walker B) (Takken et al., 2006). The presence of conserved NLR domain architecture in both plants and animals indicates that these proteins are elegantly designed to function as molecular switches depending on the bound nucleotide. Consistent with this hypothesis, key mutations within the P-loop completely abolish nucleotide binding and typically render NLRs inactive (Takken and Govere, 2012). Three amino acids, MHD, are frequently conserved in the NB-ARC domain of active NLRs and MHD mutations are thought to enlarge the nucleotide binding pocket making nucleotide exchange and ATP binding more favorable, resulting in autoactivity (Takken and Govere, 2012). The current model of plant NLR activation suggests that in a resting state, the CC or TIR domain in conjunction with the LRR inhibits nucleotide exchange. Effector perception is hypothesized to trigger opening of the receptor, alter intra- and inter-molecular interactions, and promote exchange of ADP for ATP, triggering downstream signaling (Takken and Govere, 2012) (Figure 2). These molecular rearrangements could acti-

vate downstream signaling through changes in protein localization, release of inhibitory effects on client proteins or dynamic interactions with new sets of clients (Elmore et al., 2011). It is interesting to note that purified NLR proteins can bind both ATP and ADP (Tamelung et al., 2002). Thus, it is possible that these NLRs are continually cycling between active and inactive states, with effector perception “locking” the immune receptor into a more stable active state. Alternatively, NLR association with the conserved chaperone complex at a resting state could enhance ADP binding.

### EXAMPLES OF DIRECT AND INDIRECT RECOGNITION

NLRs can either directly or indirectly recognize corresponding pathogen effectors (Figure 2). The *RECOGNITION OF PERONOSPORA PARASITICA 1* (*RPP1*: AT3G44480) locus comprises a cluster of NLRs and several members recognize specific effectors from the oomycete pathogen *Hyaloperonospora arabidopsidis* (*Hpa*) (Botella et al., 1998). *RPP1*-mediated recognition of the *ATR1* effector is consistent with a model of direct recognition. Distinct *ATR1* alleles are differentially recognized by *RPP1* and individual *RPP1* alleles also vary in their recognition specificity (Krasileva et al., 2010). *ATR1* can associate with the LRR domain of *RPP1*-WsB from the Arabidopsis accession Wassilewskija (Ws) and mutational analyses of surface localized residues on *ATR1* affect its ability to associate with its cognate NLR (Krasileva et al., 2010; Chou et al., 2011; Steinbrenner et al., 2015).

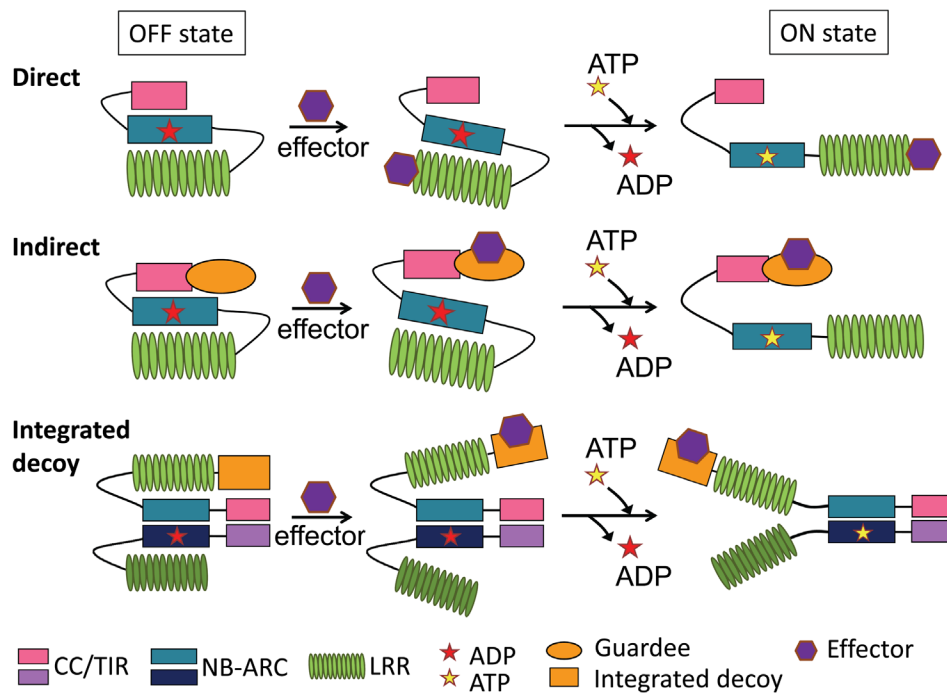

**Figure 2.** Models of NLR activation.

**A.** Direct recognition model. At a resting state, the NLR receptor domains are compact and the NB-ARC region is bound to ADP. Upon effector binding, the NLR receptor opens, exchanges ADP for ATP, and initiates downstream immune signaling. ATP can subsequently be hydrolyzed and the receptor returned to a resting state.

**B.** Indirect recognition model. At a resting state, the NLR receptor also associates with a guarded protein. The NLR receptor recognizes effector-induced modification of the guardee, triggering receptor opening, ATP binding, and initiation of downstream signaling.

**C.** Integrated decoy model. Two paired NLRs coordinate pathogen perception and downstream signaling. The sensor NLR possesses an additional domain and dimerizes with a signaling NLR exhibiting classical domain architecture. The signaling NLR senses effector-induced modification of the sensor, triggering receptor opening, ATP binding and initiation of downstream signaling. The ability to bind ATP is not required for the function of the sensor NLR. CC = coiled-coiled domain, TIR = Toll/Interleukin-1 receptor-like domain, NB-ARC = nucleotide-binding adaptor shared by APAF-1, R proteins, and CED-4, LRR = leucine rich repeat, ADP = adenosine diphosphate, ATP = adenosine triphosphate.

In the case of indirect recognition, the NLR “guards” a key host protein and detects effector-induced modification of the guarded protein (Jones and Dangl, 2006) (Figure 2). The guarded protein can either be a *bona fide* effector virulence target or a decoy (van der Hoorn and Kamoun, 2008). The Arabidopsis NLR RESISTANCE TO PSEUDOMONAS SYRINGAE 5 (RPS5: AT1G12220) indirectly recognizes the AvrPphB pathogen effector from *Pseudomonas syringae*. AvrPphB is delivered inside host cells during infection and acts as a cysteine protease, cleaving the plant kinase AvrPphB SUSCEPTIBLE 1 (PBS1: AT5G13160) (Shao et al., 2003). RPS5 monitors PBS1 and is activated by PBS1 cleavage, leading to ETI (Ade et al., 2007). PBS1 and related kinases are important immune signaling proteins and serve as AvrPphB virulence targets in susceptible genetic backgrounds (Zhang et al., 2010). Interestingly, RPS5 is capable of sensing PBS1 cleavage products as well as PBS1 with a five amino acid alanine insertion located within its cleavage site (DeYoung et al., 2012). Furthermore, the RESISTANCE TO PSEUDOMONAS SYRINGAE

PV. MACULICOLA 1 (RPM1: AT3G07040) NLR can be activated by either phosphorylation of its guardee RPM1 INTERACTING PROTEIN 4 (RIN4: AT3G25070) at threonine 166 or by deletion of a nearby residue, proline 149 (Chung et al., 2011; Liu et al., 2011; Li et al., 2014b) (Figure 3). Although RPS5 and RPM1 can sense specific modification of a guarded protein, they can also be activated by mutating regions surrounding the modified residue. Thus, NLRs may be capable of sensing a general disruption in the fold of guarded targets, which could enable recognition of diverse effectors with similar host targets.

## NLR BIOLOGY

In animals, NLRs are well known to oligomerize upon activation, forming an inflammasome which acts as a signaling scaffold (Philpott et al., 2014). Mouse NLRC4 heterodimerizes with either NAIP5 or NAIP2 and the presence of either NAIP protein deter-

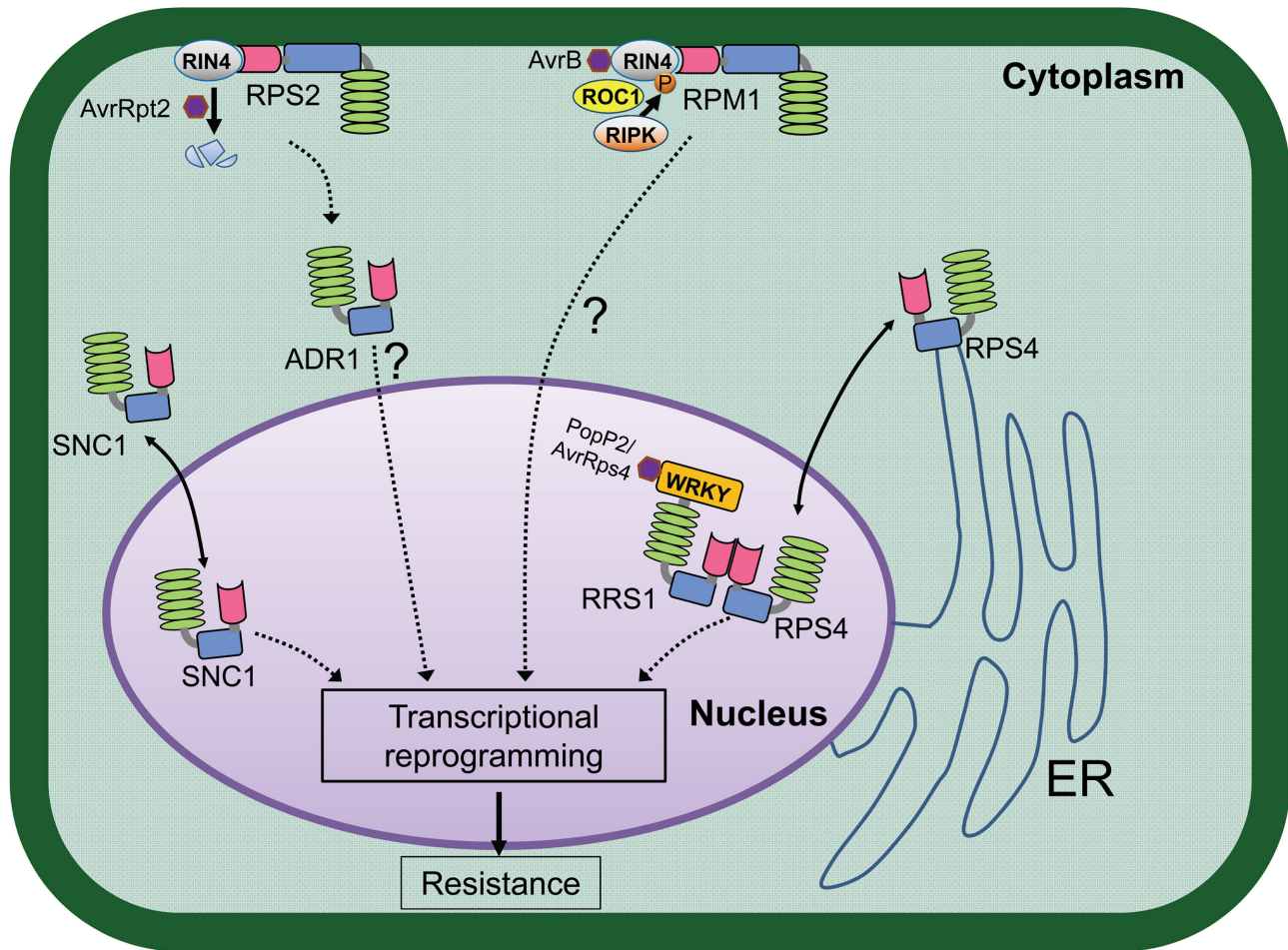

**Figure 3.** Activation of effector triggered immunity by NLRs residing in distinct subcellular compartments.

Arabidopsis NLRs with their corresponding “guardees” and pathogen effectors. **RPS2** is associated with the plasma membrane and guards RIN4. RPS2 is activated upon cleavage of RIN4 by the AvrRpt2 effector. The helper NLR ADR1 is also involved in RPS2-mediated immunity. **RPM1** is also associated with the plasma membrane and guards RIN4. RPM1 perceives the bacterial effector AvrB, which induces RIN4 phosphorylation through host kinases such as RIPK. **RPS4** associates with the endoplasmic reticulum (ER) and exhibits partial nuclear localization. RPS4 functions with another NLR, **RRS1** which also possesses a WRKY domain. RRS1 associates with RPS4 independently of effector binding. The effectors PopP2 and AvrRps4 target RRS1’s WRKY domain, facilitating the formation of an active RRS1-RPS4 complex to trigger downstream defense responses. **SNC1** possesses both a nuclear localization signal (NLS) and a nuclear export signal (NES) and shuttles between the nucleus and cytoplasm. Solid arrows indicate the nuclear-cytoplasmic trafficking of NLRs. Dotted arrows indicate indirect regulation or unknown signaling pathways (question marks).

mines the specificity of the inflammasome to bacterial MAMP perception (Kofoed and Vance, 2011; Zhao et al., 2011). Recent research has also demonstrated that several plant CNLs and TNLs can self-associate. Furthermore, some Arabidopsis NLRs can heterodimerize, with both NLRs required for a robust immune response. These examples of NLR cooperation are discussed below in detail.

#### NLR Self-Association

One example of an Arabidopsis NLR that can self-associate is RPS5. Differentially tagged full length RPS5 proteins co-immu-

noprecipitated with each other when transiently expressed in *Nicotiana benthamiana* (Ade et al., 2007). Furthermore, individual RPS5 domains (CC, CC-NB-ARC, NB-ARC, and LRR) co-immunoprecipitated with both themselves and full-length RPS5, suggesting that all domains contribute to the RPS5’s intermolecular interactions (Ade et al., 2007). TIR domains from other Arabidopsis TNLs can also self-associate, including RPP1 (Krasileva et al., 2010) and RESISTANCE TO PSEUDOMONAS SYRINGAE 4 (RPS4: AT5G45250) (Williams et al., 2014). Several lines of evidence highlight the importance of TIR dimerization for inducing cell death. GFP and related fluorescent proteins undergo spontaneous dimerization (Day and Davidson, 2009). Expression of RPP1’s TIR domain fused to GFP in *N. tabacum* triggered effec-

tor-independent cell death. However, RPP1's TIR domain fused with monomeric GFP was unable to elicit cell death (Krasileva et al., 2010). Williams et al. (2014) mutated several residues on RPS4's TIR domain to generate dimeric or monomeric TIR variants, demonstrating the requirement of TIR dimerization for eliciting cell death. These results indicate that TIR self-association plays an important role in the induction of the HR. The TIR domain in full length TNLs may not self-associate at a resting state, but ATP binding could trigger TIR association and downstream defense responses.

Other CNLs and TNLs can form homodimers or oligomers, such as tobacco N, flax L6 and barley MLA10 (Mestre and Baulcombe, 2006; Bernoux et al., 2011; Maekawa et al., 2011). Collectively, these experiments indicate that NLR self-association is a common mechanism required for ETI-triggered HR. The majority of the experiments conducted to date are performed using transient expression with the HR as an indication of ETI. Genetically, HR and resistance can be uncoupled in several cases (Clough et al., 2000; Coll et al., 2010). Therefore, it will be important to assess the role of NLR self-association for inhibiting pathogen proliferation.

### NLR Pairs

An increasing number of elegant genetic studies have highlighted cooperation between genetically linked NLRs for regulating disease resistance in both monocots and dicots (Césari et al., 2014a). In multiple cases, the two NLRs are in a head-to-head orientation sharing a promoter and one of the NLRs possesses an additional domain that is targeted by pathogen effectors (Césari et al., 2014b; Le Roux et al., 2015; Sarris et al., 2015). These findings led to a new model of NLR recognition, called the integrated decoy hypothesis (Césari et al., 2014a) (Figure 2). In this model, a sensor NLR, possessing an additional unique domain, acts as a decoy by mimicking the effector virulence target. Effector binding then facilitates activation of the second signaling NLR with classical domain architecture, leading to ETI (Césari et al., 2014a). It is also possible that pathogen effectors directly target sensor NLRs to facilitate pathogen virulence in susceptible genotypes (Wu et al., 2015). The extra domain present on the sensor NLR could either be a decoy or a *bona fide* effector virulence target (Wu et al., 2015). Multiple head-to-head NLR pairs with one member possessing an additional domain have been identified, indicating that the integrated decoy hypothesis may be one broadly conserved mechanism for NLR activation (Césari et al., 2014a). Below, we will discuss two examples of this model.

In Arabidopsis, the TNLs *RPS4* and *RESISTANT TO RALSTONIA SOLANACEARUM 1* (*RRS1*: AT5G45260) function in concert to mediate recognition of unrelated effector proteins from three distinct pathogens: the bacterial effector AvrRps4 from *P. syringae* pv. *pisii*, the bacterial effector PopP2 from *Ralstonia solanacearum*, and an unknown effector from the fungal pathogen *Colletotrichum higginsianum* (Narusaka et al., 2009). *RPS4* exhibits classical TNL domain architecture, while the *RRS1* TNL also possesses a C-terminal WRKY motif that is characteristic of some plant transcription factors (Figure 1, Figure 3). *RPS4* and *RRS1* reside within a single locus with a head-to-head tandem

orientation. Homodimerization of *RPS4*'s TIR domain induces cell death that is suppressed by the heterodimerization of *RPS4* and *RRS1* (Williams et al., 2014). Furthermore, an intact P-loop motif of *RPS4* NB-ARC domain is required for AvrRps4 or PopP2-triggered cell death whereas a P-loop mutation on *RRS1* did not abolish effector-triggered cell death (Williams et al., 2014). Collectively, these data indicate that *RRS1* acts as the sensor NLR, while *RPS4* functions as a signaling NLR.

The bacterial effectors AvrRps4 and PopP2 target *RRS1*'s WRKY domain. The PopP2 effector acts as an acetyltransferase and acetylates *RRS1*'s WRKY domain, resulting in reduced DNA binding (Le Roux et al., 2015; Sarris et al., 2015). It is proposed that effector binding to *RRS1*'s WRKY domain induces a conformational change, followed by release of the *RRS1*-*RPS4* complex from bound DNA and formation of an active *RRS1*-*RPS4* complex capable of triggering downstream defense responses (Williams et al., 2014; Le Roux et al., 2015; Sarris et al., 2015). PopP2 acetylates several WRKY transcription factors and disables defense gene activation, consistent with the hypothesis that *RRS1*'s WRKY domain acts as a decoy (Le Roux et al., 2015; Sarris et al., 2015).

In the Arabidopsis genome, several close homologs of *RPS4* and *RRS1* are also linked in a head-to-head tandem orientation, indicating that these NLRs may also function as pairs (Narusaka et al., 2009). Recently, another Arabidopsis TNL pair (*RPS4B*: AT5G45060 and *RRS1B*: AT5G45050) with head-to-head tandem orientation and 60% identity to the *RPS4*-*RRS1* pair was found to mediate resistance against AvrRps4, but not PopP2 (Saucet et al., 2015). Although inappropriate pairs (*RPS4B*-*RRS1* and *RPS4*-*RRS1B*) exist in some ecotypes, they are unable to recognize AvrRps4 or PopP2 (Saucet et al., 2015). Thus, effector recognition by this set of paired NLRs requires the appropriate partner for function and specificity.

NLR pairs are also frequently found in monocots (Césari et al., 2014a). Two tightly linked rice CNLs, R GENE ANALOG (RGA) 4 and 5 associate through their coiled-coil domains and functionally cooperate to regulate resistance to the fungal pathogen *Magnaporthe oryzae* (Césari et al., 2014b). The RGA4 signaling NLR constitutively triggers an effector-independent cell death which is repressed by the RGA5 sensor NLR. The AVR-Pia effector directly interacts with RGA5's RATX1 domain, leading to the activation of RGA4-mediated signaling (Césari et al., 2013; Césari et al., 2014b). Characterized as well as predicted sensor NLRs possess a wide variety of unique domains, which is consistent with the hypothesis that these domains are acting to bait effectors as opposed to being directly involved in downstream immune signaling.

### Helper NLRs

In plant and animal systems, NLRs can also function in downstream signaling after initial pathogen perception. Tobacco NRG1, which is required for N-mediated immune response, was the first "helper" NLR to be identified (Peart et al., 2005). NRG1 and other characterized helper NLRs are CNLs whose N-terminal CC domain resembles the Arabidopsis RESISTANCE TO POWDERY MILDEW 8 (RPW8) protein (Collier et al., 2011). This CC domain lacks the EDVID motif, has been termed CC<sub>R</sub>, and is present in

a basal clade with two distinct subgroups (Collier and Moffett, 2009; Collier et al., 2011). One subgroup is exemplified by NRG1. The second subgroup is exemplified by Arabidopsis ACTIVATED DISEASE RESISTANCE 1 (ADR1: AT1G33560), another helper NLR and that functions downstream of initial immune perception (Bonardi et al., 2011). The Arabidopsis CNL ADR1 and two other family members (ADR1-LIKE 1: AT4G33300 and ADR1-LIKE 2: AT5G04720) contribute to ETI mediated by RESISTANCE TO PSEUDOMONAS SYRINGAE 2 (RPS2: AT4G26090), RECOGNITION OF PERONOSPORA PARASITICA 2 (RPP2), and RECOGNITION OF PERONOSPORA PARASITICA 4 (RPP4: AT4G16860) (Bonardi et al., 2011). RPS2 indirectly recognizes the AvrRpt2 effector, which is a protease and cleaves the plant protein RIN4 (Axtell and Staskawicz, 2003; Mackey et al., 2003) (Figure 3). The *adr1* triple mutant exhibited compromised RPS2-mediated responses. However, AvrRpt2 was still able to effectively cleave RIN4 in the *adr1* triple mutant, indicating that the ADR1 family functions downstream of initial pathogen perception (Bonardi et al., 2011).

The ADR1 family is also required for basal defense against virulent pathogens such as *Hpa* Emco5 and *P. syringae* pv. *tomato* (*Pto*) DC3000, highlighting overlap between PTI and ETI signaling networks (Bonardi et al., 2011). *ADR1-L2* helper activity is P-loop independent (Bonardi et al., 2011). Surprisingly, mutation of the *ADR1-L2* MHD motif leads to a dwarfed phenotype and enhanced resistance to *Hpa* Emco5 and *Pto* DC3000 (Roberts et al., 2013). Thus, apart from P-loop independent helper activity, *ADR1-L2* also exhibits canonical P-loop dependent NLR activity (Roberts et al., 2013). Distinct helper NLRs may serve as adaptors to transduce immune signaling from plasma membrane (PM)-localized NLRs to downstream signaling components. Future studies focused on determining if helper NLRs interact directly with receptor NLRs in plants will enhance our understanding of early immune signaling.

## DIVERSE NLR SUBCELLULAR LOCALIZATIONS

NLR proteins are found in diverse subcellular localizations, from the cytoplasmic side of the plasma membrane to the cytosol and nucleus. In Arabidopsis, 51 TNL and 39 CNL proteins possess predicted monopartite or bipartite nuclear localization signals (NLSs) (Shen and Schulze-Lefert, 2007). Multiple studies have drawn attention to the nucleo-cytoplasmic trafficking of plant NLR proteins and their functions in the nucleus (Figure 3) (reviewed in Liu and Coaker, 2008). RRS1 contains several predicted NLSs and its nuclear localization is dependent on the presence of the nuclear-targeted effector PopP2 (Deslandes et al., 2003). RPS4, which functions in concert with RRS1, associates with endomembranes and exhibits partial nuclear localization (Figure 3). The nuclear pool of RPS4 is essential for RRS1/RPS4 resistance to *Pto* DC3000 expressing AvrRps4 (Wirthmueller et al., 2007). However, there is no major nuclear re-localization of RPS4 upon AvrRPS4 recognition (Wirthmueller et al., 2007). Another example of an Arabidopsis NLR exhibiting nucleocytoplasmic localization is SUPPRESSOR OF NPR1-1, CONSTITUTIVE 1 (SNC1: AT4G16890) (Cheng et al., 2009) (Figure 3). SNC1 possesses canonical TNL structure and contains both an NLS and nuclear

export signal (NES). *snc1* was first identified as a gain-of-function mutant with a point mutation in the region between the NB-ARC and LRR domains (Zhang et al., 2003). Three suppressors of the *snc1* mutant have highlighted the importance of nucleo-cytoplasmic distributions for NLR immune responses. These suppressors of *snc1* include importin  $\alpha$ 3, nucleoporin 88, and nucleoporin 96 (Palma et al., 2005; Zhang and Li, 2005; Cheng et al., 2009). The *nucleoporin 88* mutant exhibits defects in basal defense responses against *P. syringae* pv. *maculicola* ES4326 and several NLR-mediated immune responses, such as those controlled by RPM1, RPP4, RPS4, and RPS5 (Cheng et al., 2009). Furthermore, *snc1* requires an intact P-loop for activation, can oligomerize in either the nucleus or cytoplasm, with *snc1* nuclear pools required for activation of downstream immune responses (Xu et al., 2014a) (Figure 3).

Other plant NLRs also exhibit dynamic nucleo-cytoplasmic distribution. The tobacco TNL N recognizes a viral effector in the cytoplasm and subsequently relocates to the nucleus for defense responses (Burch-Smith et al., 2007; Caplan et al., 2008). The potato CNL Rx1, which confers resistance to *Potato virus X*, exhibits nucleo-cytoplasmic localization (Slootweg et al., 2010). Forced localization experiments revealed that Rx1 is activated in the cytoplasm, but both nuclear and cytoplasmic pools are required for a full ETI response (Slootweg et al., 2010). These studies as well as others have highlighted the importance of appropriate subcellular distribution and extensive coordination across subcellular compartments for full resistance.

## IMMUNE SIGNALING DOWNSTREAM OF NLR ACTIVATION

Despite the importance of innate immune responses, the immediate targets of activated immune receptors remain largely unknown. Forward genetic screens have identified few robust ETI signaling components, implicating short signaling pathways or high genetic redundancy. Some nucleo-cytoplasmic NLRs can directly interact with transcription factors, indicating that signal transduction downstream of NLR activation can be very short (Chang et al., 2013; Inoue et al., 2013; Padmanabhan et al., 2013). In Arabidopsis, RPS4 and SNC1 interact with the transcription factor bHLH84 and its paralogs to regulate ETI (Xu et al., 2014b). Although NLR activation triggers extensive transcriptional reprogramming, not all NLR proteins translocate to the nucleus or directly interact with transcription factors. How NLRs with diverse localizations trigger a similar set of ETI responses is a major unanswered research question.

Genetic screens have highlighted the importance of a conserved chaperone complex as well as core loci generally required for CNL and TNL responses. The conserved chaperone complex is required for NLR stability and consists of HEAT SHOCK PROTEIN 90 (HSP90), SUPPRESSOR OF THE G2 ALLELE OF SKP1 (SGT1A: AT4G23570 and SGT1B: AT4G11260), and REQUIRED FOR MLA12 RESISTANCE 1 (RAR1: AT5G51700) (Shirasu, 2009). NDR1, a plasma membrane-anchored integrin-like protein, is required for ETI induced by multiple CNLs (Century et al., 1995; Day et al., 2006; Knepper et al., 2011). NDR1 also associates with RIN4 which is guarded by the plasma membrane localized CNLs RPM1 and RPS2 (Day et al., 2006; Knepper et

al., 2011). EDS1, a nucleocytoplasmic lipase-like protein, is required for ETI induced by multiple TNLs and regulates basal defense responses. EDS1 was found to form protein complexes with several Arabidopsis TNLs including RPS4, RESISTANCE TO PSEUDOMONAS SYRINGAE 6 (RPS6: AT5G46470), and SNC1 (Bhattacharjee et al., 2011). Although EDS1 has similarity to lipases, mutation of potential lipase catalytic sites indicates that the catalytic activity of EDS1's lipase domain is dispensable for ETI signaling (Wagner et al., 2013). Rather, EDS1 mediates ETI by association with PAD4, SENESCENCE-ASSOCIATED GENE 101 (SAG101: AT5G14930) and the adapter protein SUPPRESSOR OF RPS4-RLD1 (SRFR1: AT4G37460) (Feys et al., 2005; Xing and Chen, 2006; Kwon et al., 2009; Rietz et al., 2011; Wagner et al., 2013). SRFR1 is recruited in EDS1-TNL complexes. SRFR1 interacts with several TCP transcription factors and is predicted to act as a transcriptional repressor (Kim et al., 2014). EDS1 has also been reported to be "guarded" by the NLRs RPS4 and RPS6 (Bhattacharjee et al., 2011; Heidrich et al., 2011) (Figure 3). However, Sohn and colleagues (2012) were unable to co-immunoprecipitate EDS1 and AvrRps4 in *N. benthamiana*. Future experiments using alternative methods to detect protein interactions will help determine if AvrRps4 directly targets EDS1.

#### CELLULAR CHANGES ASSOCIATED WITH EFFECTOR-TRIGGERED IMMUNITY

NLR activation leads to diverse cellular changes including sustained  $Ca^{2+}$  influx, elevated ROS levels, MAP kinase activation, alteration of endomembrane trafficking, transcriptional reprogramming, and the HR (Cui et al., 2015). Dynamic rearrangements of the endomembrane system and alterations in membrane trafficking occur during ETI to inhibit pathogen proliferation (Teh and Hofius, 2014). Activation of the NLRs RPS2 and RPM1 led to the fusion of membranes between the central vacuole and the plasma membrane, resulting in the release of vacuolar antimicrobial proteins to the apoplast with cell death inducing activity (Hatsugai et al., 2009). This membrane fusion is mediated by a  $\beta$ -subunit of 26S proteasome called PBA1 (AT4G31300) which acts as a caspase-3-like protein (Hatsugai et al., 2009). Quantitative proteomic analyses of plasma membrane-enriched fractions highlighted the upregulation of proteins involved in endocytosis and exocytosis during RPS2 activation (Elmore et al., 2012). A number of different vesicle trafficking components are involved in regulating plant immunity (Teh and Hofius, 2014). Mutations in *VPS35 HOMOLOG B* (*VPS35B*: AT1G75850) are compromised in a subset of NLR mediated responses, including the HR (Munch et al., 2015). *VPS35B* is a component of the retromer complex, which functions in endosomal protein sorting as well as vacuolar trafficking. Pathogen effectors also target membrane trafficking components in order to promote pathogen virulence (Nomura et al., 2006). The *P. syringae* effector HopM1 targets HOPM INTERACTOR 7 (AtMIN7: AT3G43300), a vesicle trafficking regulator, and induces AtMIN7 degradation via the proteasome (Nomura et al., 2006). During ETI, HopM1-mediated degradation of AtMIN7 is suppressed in order to inhibit effector triggered susceptibility (Nomura et al., 2011). These data highlight membrane trafficking as a key battleground during pathogen infection.

Unlike animals, plants lack homologous caspases to trigger cell death (Spoel and Dong, 2012). Other important mediators of HR development are the Arabidopsis metacaspases *AtMC1* and ARABIDOPSIS THALIANA METACASPASE 2 (*AtMC2*: AT4G25110), which play antagonistic roles in the regulation of cell death (Coll et al., 2010). Metacaspases are related to caspases and are proteases that cleave substrates after Arginine and Lysine residues (Vercammen et al., 2004). Although mutations on the catalytic sites of *AtMC1* eliminate HR triggered by NLR activation in mature Arabidopsis, they do not lead to enhanced pathogen proliferation (Coll et al., 2010). Autophagy can also act to regulate HR in a parallel pathway with *AtMC1*, consistent with both autophagy and *AtMC1* positively regulating cell death in young plants but negative regulating cell death in mature plants (Coll et al., 2014).

In response to pathogen infection, a biphasic ROS accumulation is detected during the activation of both PTI and ETI. Increased ROS production is cytotoxic to pathogens (Chen and Schopfer, 1999), leads to cell wall reinforcement (Bradley et al., 1992; Hükelhoven, 2007), and has an important signaling role (Kovtun et al., 2000; Mou et al., 2003). The first phase of ROS accumulation is mainly in the apoplast and occurs within minutes after infection. The first phase is regulated by NADPH oxidases called *Respiratory Burst Oxidase Homologs* (*RBOHs*) which localize to the plasma membrane and produce apoplastic ROS (Keller et al., 1998). *RBOH* proteins have two calcium-binding EF-hand motifs at their N-terminus and are phosphorylated by multiple calcium-dependent protein kinases (CPKs) (Kobayashi et al., 2007; Boudsocq et al., 2010; Dubiella et al., 2013; Gao et al., 2013), calcineurin B-like proteins (CBLs) and CBL-interacting protein kinases (CIPKs) (de la Torre et al., 2013). In Arabidopsis, CPK4, 5, 6 and 11 (AT4G09570, AT4G35310, AT2G17290, and AT1G35670) were shown to positively regulate ROS production during PTI (Boudsocq et al., 2010). CPK5 can directly phosphorylate *RBOHD* (AT5G47910) (Dubiella et al., 2013). Recently, it was shown that Arabidopsis *RBOHD* is a part of the PRR complex and can also be directly phosphorylated by BOTRYTIS-INDUCED KINASE1 (BIK1: AT2G39660) at specific sites upon PAMP perception to enhance *RBOHD* activity (Kadota et al., 2014; Li et al., 2014a). It will be interesting to examine the role of both CPK and BIK1 specific *RBOHD* phosphorylation sites during ETI.

In Arabidopsis, the *atrbohD/F* (AT5G47910/ AT1G64060) double mutant exhibited reduced ROS burst and HR in response to the avirulent bacterial pathogen *Pto* DC3000 (*avrRpm1*), but had no effect on bacterial growth (Torres et al., 2002). However, when infected with the avirulent oomycete *Hpa* Emco5, the *atrbohD/F* double mutant showed enhanced cell death and resistance despite decreased ROS production (Torres et al., 2002). ROS production can be uncoupled from the HR in some plant-pathogen interactions (Glazener et al., 1996; Yano et al., 1999). These data indicate that *RBOHs* are crucial for extracellular ROS production during pathogen infection, but their connection with cell death requires further investigation. The second phase of ROS production occurs several hours after pathogen infection. ETI and the HR is associated with this prolonged phase of ROS production (Wojtaszek, 1997; Grant and Loake, 2000). Multiple organelles including chloroplasts, mitochondria, and peroxisomes contribute to ROS production during HR, and chloroplasts play a pivotal role in intracellular



ROS production (Doyle et al., 2010; Shapiguzov et al., 2012). Intracellular ROS are not only involved in mediating cell death during the HR but also serve as signaling molecules to up-regulate defense-related gene expression (Straus et al., 2010). However, it is still unclear how these intracellular ROS produced from different organelles serve as signals to initiate and promote HR and regulate gene expression in the nucleus.

NLR activation also leads to a prolonged and sustained increase of cytosolic  $\text{Ca}^{2+}$  which is required for the HR (Grant et al., 2000; Ma et al., 2008). Thirty-four CPKs are encoded in the Arabidopsis genome (Cheng et al., 2002). Several of them are involved in regulating different aspects of plant immunity. Similar to potato CPK4 and CPK5, constitutively active AtCPK1, 2, 4, and 11 (AT5G04870, AT3G10660, AT4G09570, and AT1G35670) phosphorylate the cytoplasmic N-terminus of both RBOHD and RBOHF (Gao et al., 2013) resulting in enhanced ROS production. The *cpk1/cpk2* double mutant exhibited reduced ROS production upon inoculation with *Pseudomonas* expressing *avrRpm1* or *avrRpt2* (Gao et al., 2013). CPKs can also directly regulate transcriptional reprogramming by phosphorylating WRKY transcription factors in a calcium-dependent manner, regulating WRKY promoter binding activity (Gao et al., 2013). These data highlight the importance of calcium signaling and CPKs for NLR-mediated defense.

## CONCLUSIONS AND FUTURE DIRECTIONS

The recent discovery of NLR cooperation and paired NLRs has advanced the field of plant immunity. An increasing number of plant genome sequences are available, enabling the identification of multiple linked NLR pairs. Future research elucidating how each member of distinct NLR pairs function will significantly advance our understanding of plant immune perception. Furthermore, how downstream helper NLRs, such as ADR1, interface with primary receptor NLRs remains to be elucidated. Multiple unanswered questions remain about the conservation of signaling components immediately downstream of multiple NLRs with diverse subcellular localizations. Addressing these important areas will significantly enhance our understanding of NLR biology.

Significant progress has been made understanding the importance of NLR cooperation, NLR subcellular localization, and transcriptional reprogramming towards defense. However, several fundamental questions related to early immune signaling remain elusive: What are the conformational differences between active and inactive NLR receptors? How do distinct NLR domains work together? Purification of soluble full-length plant NLRs with high purity and homogeneity has been an obstacle impeding the progress of obtaining NLR structures. Recent advancements in direct electron detectors and imaging processing software have revolutionized our ability to determine high molecular weight protein structures using cryo-electron microscopy with relatively low sample concentrations (Kühlbrandt, 2014). Thus, obtaining the structures of full-length NLRs and their complexes may be feasible in the near future. Solving plant NLR structures in an active and inactive state will enable scientists to directly test models of

NLR activation and pave the way to synthetic engineering of immune receptors with novel recognition specificity.

## ACKNOWLEDGEMENTS

We thank James Elmore and Tania Toruño for critical reading of the manuscript. This work was made possible by grants from the National Science Foundation (MCB-1054298), the Agriculture and Food Research Initiative competitive grant no. 2015-67013-23082 of the USDA National Institute of Food and Agriculture, and National Institutes of Health (R01-GM092772) awarded to GC.

## REFERENCES:

- Ade, J., DeYoung, B.J., Golstein, C., and Innes, R.W. (2007). Indirect activation of a plant nucleotide binding site–leucine-rich repeat protein by a bacterial protease. *Proc. Natl. Acad. Sci. USA* **104**, 2531-2536.
- Axtell, M.J., and Staskawicz, B.J. (2003). Initiation of RPS2-Specified Disease Resistance in Arabidopsis Is Coupled to the AvrRpt2-Directed Elimination of RIN4. *Cell* **112**, 369-377.
- Bernoux, M., Ve, T., Williams, S., Warren, C., Hatters, D., Valkov, E., Zhang, X., Ellis, Jeffrey G., Kobe, B., and Dodds, Peter N. (2011). Structural and Functional Analysis of a Plant Resistance Protein TIR Domain Reveals Interfaces for Self-Association, Signaling, and Auto-regulation. *Cell Host & Microbe* **9**, 200-211.
- Bhattacharjee, S., Halane, M.K., Kim, S.H., and Gassmann, W. (2011). Pathogen Effectors Target Arabidopsis EDS1 and Alter Its Interactions with Immune Regulators. *Science* **334**, 1405-1408.
- Bonardi, V., Tang, S., Stallmann, A., Roberts, M., Cherkis, K., and Dangl, J.L. (2011). Expanded functions for a family of plant intracellular immune receptors beyond specific recognition of pathogen effectors. *Proc. Natl. Acad. Sci. USA* **108**, 16463-16468.
- Botella, M.A., Parker, J.E., Frost, L.N., Bittner-Eddy, P.D., Beynon, J.L., Daniels, M.J., Holub, E.B., and Jones, J.D.G. (1998). Three Genes of the Arabidopsis RPP1 Complex Resistance Locus Recognize Distinct *Peronospora parasitica* Avirulence Determinants. *Plant Cell* **10**, 1847-1860.
- Boudsocq, M., Willmann, M.R., McCormack, M., Lee, H., Shan, L., He, P., Bush, J., Cheng, S.-H., and Sheen, J. (2010). Differential innate immune signalling via  $\text{Ca}^{2+}$  sensor protein kinases. *Nature* **464**, 418-422.
- Bradley, D.J., Kjellbom, P., and Lamb, C.J. (1992). Elicitor- and wound-induced oxidative cross-linking of a proline-rich plant cell wall protein: A novel, rapid defense response. *Cell* **70**, 21-30.
- Burch-Smith, T.M., Schiff, M., Caplan, J.L., Tsao, J., Czymmek, K., and Dinesh-Kumar, S.P. (2007). A Novel Role for the TIR Domain in Association with Pathogen-Derived Elicitors. *PLoS Biol* **5**, e68.
- Caplan, J.L., Mamillapalli, P., Burch-Smith, T.M., Czymmek, K., and Dinesh-Kumar, S.P. (2008). Chloroplastic protein NRIP1 mediates innate immune receptor recognition of a viral effector. *Cell* **132**, 449-462.
- Century, K.S., Holub, E.B., and Staskawicz, B.J. (1995). NDR1, a locus of Arabidopsis thaliana that is required for disease resistance to both a bacterial and a fungal pathogen. *Proc. Natl. Acad. Sci. USA* **92**, 6597-6601.
- Césari, S., Bernoux, M., Moncuquet, P., Kroj, T., and Dodds, P.N. (2014a). A novel conserved mechanism for plant NLR protein pairs: the 'integrated decoy' hypothesis. *Front. Plant Sci.* **5**:606. doi: 10.3389/fpls.2014.00606

- Césari, S., Kanzaki, H., Fujiwara, T., Bernoux, M., Chalvon, V., Kawano, Y., Shimamoto, K., Dodds, P., Terauchi, R., and Kroj, T.** (2014b). The NB-LRR proteins RGA4 and RGA5 interact functionally and physically to confer disease resistance. *EMBO* **33**, 1941-1959.
- Césari, S., Thilliez, G., Ribot, C., Chalvon, V., Michel, C., Jauneau, A., Rivas, S., Alaux, L., Kanzaki, H., Okuyama, Y., Morel, J.-B., Fournier, E., Tharreau, D., Terauchi, R., and Kroj, T.** (2013). The Rice Resistance Protein Pair RGA4/RGA5 Recognizes the Magnaporthe oryzae Effectors AVR-Pia and AVR1-CO39 by Direct Binding. *Plant Cell* **25**, 1463-1481.
- Chang, C., Yu, D., Jiao, J., Jing, S., Schulze-Lefert, P., and Shen, Q.-H.** (2013). Barley MLA Immune Receptors Directly Interfere with Antagonistically Acting Transcription Factors to Initiate Disease Resistance Signaling. *Plant Cell* **25**, 1158-1173.
- Chen, S.-x., and Schopfer, P.** (1999). Hydroxyl-radical production in physiological reactions. *European J. Biochem.* **260**, 726-735.
- Cheng, S., Willmann, M.R., Chen, H., and Sheen, J.** (2002). Calcium Signaling through Protein Kinases. The Arabidopsis Calcium-Dependent Protein Kinase Gene Family. *Plant Physiol.* **129**, 469-485.
- Cheng, Y.T., Germain, H., Wiermer, M., Bi, D., Xu, F., García, A.V., Wirthmueller, L., Després, C., Parker, J.E., Zhang, Y., and Li, X.** (2009). Nuclear Pore Complex Component MOS7/Nup88 Is Required for Innate Immunity and Nuclear Accumulation of Defense Regulators in Arabidopsis. *Plant Cell* **21**, 2503-2516.
- Chou, S., Krasileva, K.V., Holton, J.M., Steinbrenner, A.D., Alber, T., and Staskawicz, B.J.** (2011). Hyaloperonospora arabidopsidis ATR1 effector is a repeat protein with distributed recognition surfaces. *Proc. Natl. Acad. Sci. USA* **108**, 13323-13328.
- Chung, E.H., da Cunha, L., Wu, A.J., Gao, Z., Cherkis, K., Afzal, A.J., Mackey, D., and Dangl, J.L.** (2011). Specific threonine phosphorylation of a host target by two unrelated type III effectors activates a host innate immune receptor in plants. *Cell Host & Microbe* **9**, 125-136.
- Clough, S.J., Fengler, K.A., Yu, I.C., Lippok, B., Smith, R.K., Jr., and Bent, A.F.** (2000). The Arabidopsis dnd1 "defense, no death" gene encodes a mutated cyclic nucleotide-gated ion channel. *Proc. Natl. Acad. Sci. USA* **97**, 9323-9328.
- Coll, N.S., Smidler, A., Puigvert, M., Popa, C., Valls, M., and Dangl, J.L.** (2014). The plant metacaspase AtMC1 in pathogen-triggered programmed cell death and aging: functional linkage with autophagy. *Cell death and differentiation* **21**, 1399-1408.
- Coll, N.S., Vercammen, D., Smidler, A., Clover, C., Van Breusegem, F., Dangl, J.L., and Epple, P.** (2010). Arabidopsis type I metacaspases control cell death. *Science* **330**, 1393-1397.
- Collier, S.M., and Moffett, P.** (2009). NB-LRRs work a "bait and switch" on pathogens. *Trends in plant science* **14**, 521-529.
- Collier, S.M., Hamel, L.-P., and Moffett, P.** (2011). Cell Death Mediated by the N-Terminal Domains of a Unique and Highly Conserved Class of NB-LRR Protein. *Molecular Plant-Microbe Interactions* **24**, 918-931.
- Cui, H., Tsuda, K., and Parker, J.E.** (2015). Effector-Triggered Immunity: From Pathogen Perception to Robust Defense. *Annual Review of Plant Biology* **66**, 487-511.
- Day, B., Dahlbeck, D., and Staskawicz, B.J.** (2006). NDR1 Interaction with RIN4 Mediates the Differential Activation of Multiple Disease Resistance Pathways in Arabidopsis. *Plant Cell* **18**, 2782-2791.
- Day, R.N., and Davidson, M.W.** (2009). The fluorescent protein palette: tools for cellular imaging. *Chemical Society Reviews* **38**, 2887-2921.
- de la Torre, F., Gutiérrez-Beltrán, E., Pareja-Jaime, Y., Chakravarthy, S., Martin, G.B., and del Pozo, O.** (2013). The Tomato Calcium Sensor Cbl10 and Its Interacting Protein Kinase Cipk6 Define a Signaling Pathway in Plant Immunity. *Plant Cell* **25**, 2748-2764.
- Deslandes, L., Olivier, J., Peeters, N., Feng, D.X., Khounlotham, M., Boucher, C., Somssich, I., Genin, S., and Marco, Y.** (2003). Physical interaction between RRS1-R, a protein conferring resistance to bacterial wilt, and PopP2, a type III effector targeted to the plant nucleus. *Proc. Natl. Acad. Sci. USA* **100**, 8024-8029.
- DeYoung, B.J., Qi, D., Kim, S.-H., Burke, T.P., and Innes, R.W.** (2012). Activation of a plant nucleotide binding-leucine rich repeat disease resistance protein by a modified self protein. *Cellular Microbiology* **14**, 1071-1084.
- Doyle, S.M., Diamond, M., and McCabe, P.F.** (2010). Chloroplast and reactive oxygen species involvement in apoptotic-like programmed cell death in Arabidopsis suspension cultures. *Journal of Experimental Botany* **61**, 473-482.
- Dubiella, U., Seybold, H., Durian, G., Komander, E., Lassig, R., Witte, C.-P., Schulze, W.X., and Romeis, T.** (2013). Calcium-dependent protein kinase/NADPH oxidase activation circuit is required for rapid defense signal propagation. *Proc. Natl. Acad. Sci. USA* **110**, 8744-8749.
- Elmore, J.M., Lin, Z.J., and Coaker, G.** (2011). Plant NB-LRR signaling: upstreams and downstreams. *Curr Opin Plant Biol* **14**, 365-371.
- Elmore, J.M., Liu, J., Smith, B., Phinney, B., and Coaker, G.** (2012). Quantitative Proteomics Reveals Dynamic Changes in the Plasma Membrane During Arabidopsis Immune Signaling. *Molecular & Cellular Proteomics* **11**, M111.014555. doi:10.1074/mcp.M111.014555
- Feys, B.J., Wiermer, M., Bhat, R.A., Moisan, L.J., Medina-Escobar, N., Neu, C., Cabral, A., and Parker, J.E.** (2005). Arabidopsis SENESCENCE-ASSOCIATED GENE101 Stabilizes and Signals within an ENHANCED DISEASE SUSCEPTIBILITY1 Complex in Plant Innate Immunity. *Plant Cell* **17**, 2601-2613.
- Gao, X., Chen, X., Lin, W., Chen, S., Lu, D., Niu, Y., Li, L., Cheng, C., McCormack, M., Sheen, J., Shan, L., and He, P.** (2013). Bifurcation of Arabidopsis NLR Immune Signaling via Ca<sup>2+</sup>-Dependent Protein Kinases. *PLoS Pathog* **9**, e1003127. doi:10.1371/journal.ppat.1003127
- Glazener, J.A., Orlandi, E.W., and Baker, C.J.** (1996). The Active Oxygen Response of Cell Suspensions to Incompatible Bacteria Is Not Sufficient to Cause Hypersensitive Cell Death. *Plant Physiol.* **110**, 759-763.
- Grant, J.J., and Loake, G.J.** (2000). Role of reactive oxygen intermediates and cognate redox signaling in disease resistance. *Plant Physiol.* **124**, 21-29.
- Grant, M., Brown, I., Adams, S., Knight, M., Ainslie, A., and Mansfield, J.** (2000). The RPM1 plant disease resistance gene facilitates a rapid and sustained increase in cytosolic calcium that is necessary for the oxidative burst and hypersensitive cell death. *Plant J.* **23**, 441-450.
- Hatsugai, N., Iwasaki, S., Tamura, K., Kondo, M., Fuji, K., Ogasawara, K., Nishimura, M., and Hara-Nishimura, I.** (2009). A novel membrane fusion-mediated plant immunity against bacterial pathogens. *Genes & Development* **23**, 2496-2506.
- Heidrich, K., Wirthmueller, L., Tasset, C., Pouzet, C., Deslandes, L., and Parker, J.E.** (2011). Arabidopsis EDS1 Connects Pathogen Effector Recognition to Cell Compartment-Specific Immune Responses. *Science* **334**, 1401-1404.
- Hückelhoven, R.** (2007). Cell Wall-Associated Mechanisms of Disease Resistance and Susceptibility. *Annual Review of Phytopathology* **45**, 101-127.
- Inoue, H., Hayashi, N., Matsushita, A., Xinqiong, L., Nakayama, A., Sugano, S., Jiang, C.-J., and Takatsuji, H.** (2013). Blast resistance of CC-NB-LRR protein Pb1 is mediated by WRKY45 through protein-protein interaction. *Proc. Natl. Acad. Sci. USA* **110**, 9577-9582.
- Johnson, K.L., and Ingram, G.C.** (2005). Sending the right signals: regulating receptor kinase activity. *Curr Opin Plant Biol* **8**, 648-656.
- Jones, J.D.G., and Dangl, J.L.** (2006). The plant immune system. *Nature* **444**, 323-329.
- Kadota, Y., Sklenar, J., Derbyshire, P., Stransfeld, L., Asai, S., Ntoukakis, V., Jones, Jonathan D., Shirasu, K., Menke, F., Jones, A., and Zipfel, C.** (2014). Direct Regulation of the NADPH Oxidase RBOHD

- by the PRR-Associated Kinase BIK1 during Plant Immunity. *Molecular Cell* **54**, 43-55.
- Keller, T., Damude, H.G., Werner, D., Doerner, P., Dixon, R.A., and Lamb, C.** (1998). A plant homolog of the neutrophil NADPH oxidase gp-91phox subunit gene encodes a plasma membrane protein with Ca<sup>2+</sup> binding motifs. *Plant Cell* **10**, 255-266.
- Kim, S.H., Son, G.H., Bhattacharjee, S., Kim, H.J., Nam, J.C., Nguyen, P.D.T., Hong, J.C., and Gassmann, W.** (2014). The Arabidopsis immune adaptor SRFR1 interacts with TCP transcription factors that redundantly contribute to effector-triggered immunity. *Plant J.* **78**, 978-989.
- Knepper, C., Savory, E.A., and Day, B.** (2011). The role of NDR1 in pathogen perception and plant defense signaling. *Plant Signaling & Behavior* **6**, 1114-1116.
- Kobayashi, M., Ohura, I., Kawakita, K., Yokota, N., Fujiwara, M., Shimamoto, K., Doke, N., and Yoshioka, H.** (2007). Calcium-Dependent Protein Kinases Regulate the Production of Reactive Oxygen Species by Potato NADPH Oxidase. *Plant Cell* **19**, 1065-1080.
- Kofoed, E.M., and Vance, R.E.** (2011). Innate immune recognition of bacterial ligands by NAIps determines inflammasome specificity. *Nature* **477**, 592-595.
- Kovtun, Y., Chiu, W.-L., Tena, G., and Sheen, J.** (2000). Functional analysis of oxidative stress-activated mitogen-activated protein kinase cascade in plants. *Proc. Natl. Acad. Sci. USA* **97**, 2940-2945.
- Krasileva, K.V., Dahlbeck, D., and Staskawicz, B.J.** (2010). Activation of an Arabidopsis Resistance Protein Is Specified by the in Planta Association of Its Leucine-Rich Repeat Domain with the Cognate Oomycete Effector. *Plant Cell* **22**, 2444-2458.
- Kühlbrandt, W.** (2014). Cryo-EM enters a new era. *eLife* **3**:e03678. doi:10.7554/eLife.03678
- Kwon, S.I., Kim, S.H., Bhattacharjee, S., Noh, J.-J., and Gassmann, W.** (2009). SRFR1, a suppressor of effector-triggered immunity, encodes a conserved tetratricopeptide repeat protein with similarity to transcriptional repressors. *Plant J.* **57**, 109-119.
- Le Roux, C., Huet, G., Jauneau, A., Camborde, L., Trémoussaygue, D., Kraut, A., Zhou, B., Levaillant, M., Adachi, H., Yoshioka, H., Raffaele, S., Berthomé, R., Couté, Y., Parker, Jane E., and Deslandes, L.** (2015). A Receptor Pair with an Integrated Decoy Converts Pathogen Disabling of Transcription Factors to Immunity. *Cell* **161**, 1074-1088.
- Li, L., Li, M., Yu, L., Zhou, Z., Liang, X., Liu, Z., Cai, G., Gao, L., Zhang, X., Wang, Y., Chen, S., and Zhou, J.-M.** (2014a). The FLS2-Associated Kinase BIK1 Directly Phosphorylates the NADPH Oxidase RbohD to Control Plant Immunity. *Cell Host & Microbe* **15**, 329-338.
- Li, M., Ma, X., Chiang, Y.-H., Yadeta, Koste A., Ding, P., Dong, L., Zhao, Y., Li, X., Yu, Y., Zhang, L., Shen, Q.-H., Xia, B., Coaker, G., Liu, D., and Zhou, J.-M.** (2014b). Proline Isomerization of the Immune Receptor-Interacting Protein RIN4 by a Cyclophilin Inhibits Effector-Triggered Immunity in Arabidopsis. *Cell Host & Microbe* **16**, 473-483.
- Liu, J., and Coaker, G.** (2008). Nuclear Trafficking During Plant Innate Immunity. *Molecular Plant* **1**, 411-422.
- Liu, J., Elmore, J.M., Lin, Z.J., and Coaker, G.** (2011). A receptor-like cytoplasmic kinase phosphorylates the host target RIN4, leading to the activation of a plant innate immune receptor. *Cell Host Microbe* **9**, 137-146.
- Ma, W., Smigel, A., Tsai, Y.-C., Braam, J., and Berkowitz, G.A.** (2008). Innate Immunity Signaling: Cytosolic Ca<sup>2+</sup> Elevation Is Linked to Downstream Nitric Oxide Generation through the Action of Calmodulin or a Calmodulin-Like Protein. *Plant Physiol.* **148**, 818-828.
- Mackey, D., Belkhadir, Y., Alonso, J.M., Ecker, J.R., and Dangl, J.L.** (2003). Arabidopsis RIN4 Is a Target of the Type III Virulence Effector AvrRpt2 and Modulates RPS2-Mediated Resistance. *Cell* **112**, 379-389.
- Maekawa, T., Cheng, W., Spiridon, Laurentiu N., Töller, A., Lukasik, E., Saijo, Y., Liu, P., Shen, Q.-H., Micluta, Marius A., Somssich, Imre E., Takken, Frank L.W., Petrescu, A.-J., Chai, J., and Schulze-Lefert, P.** (2011). Coiled-Coil Domain-Dependent Homodimerization of Intracellular Barley Immune Receptors Defines a Minimal Functional Module for Triggering Cell Death. *Cell Host & Microbe* **9**, 187-199.
- Mestre, P., and Baulcombe, D.C.** (2006). Elicitor-Mediated Oligomerization of the Tobacco N Disease Resistance Protein. *Plant Cell* **18**, 491-501.
- Meyers, B.C., Kozik, A., Griego, A., Kuang, H., and Michelmore, R.W.** (2003). Genome-wide analysis of NBS-LRR-encoding genes in Arabidopsis. *Plant Cell* **15**, 809-834.
- Mou, Z., Fan, W., and Dong, X.** (2003). Inducers of Plant Systemic Acquired Resistance Regulate NPR1 Function through Redox Changes. *Cell* **113**, 935-944.
- Munch, D., Teh, O.K., Malinovsky, F.G., Liu, Q., Vetukuri, R.R., El Kasmi, F., Brodersen, P., Hara-Nishimura, I., Dangl, J.L., Petersen, M., Mundy, J., and Hofius, D.** (2015). Retromer contributes to immunity-associated cell death in Arabidopsis. *Plant Cell* **27**, 463-479.
- Naito, K., Ishiga, Y., Toyoda, K., Shiraishi, T., and Ichinose, Y.** (2007). N-terminal domain including conserved flg22 is required for flagellin-induced hypersensitive cell death in Arabidopsis thaliana. *J Gen Plant Pathol* **73**, 281-285.
- Narusaka, M., Shirasu, K., Noutoshi, Y., Kubo, Y., Shiraishi, T., Iwabuchi, M., and Narusaka, Y.** (2009). RRS1 and RPS4 provide a dual Resistance-gene system against fungal and bacterial pathogens. *Plant J.* **60**, 218-226.
- Nomura, K., DebRoy, S., Lee, Y.H., Pumphlin, N., Jones, J., and He, S.Y.** (2006). A Bacterial Virulence Protein Suppresses Host Innate Immunity to Cause Plant Disease. *Science* **313**, 220-223.
- Nomura, K., Mecey, C., Lee, Y.N., Imboden, L.A., Chang, J.H., and He, S.Y.** (2011). Effector-triggered immunity blocks pathogen degradation of an immunity-associated vesicle traffic regulator in Arabidopsis. *Proc. Natl. Acad. Sci. USA* **108**, 10774-10779.
- Padmanabhan, M.S., Ma, S., Burch-Smith, T.M., Czymmek, K., Huijser, P., and Dinesh-Kumar, S.P.** (2013). Novel Positive Regulatory Role for the SPL6 Transcription Factor in the N TIR-NB-LRR Receptor-Mediated Plant Innate Immunity. *PLoS Pathog* **9**, e1003235. doi:10.1371/journal.ppat.1003235
- Palma, K., Zhang, Y., and Li, X.** (2005). An Importin  $\alpha$  Homolog, MOS6, Plays an Important Role in Plant Innate Immunity. *Current Biology* **15**, 1129-1135.
- Parker, J.E., Holub, E.B., Frost, L.N., Falk, A., Gunn, N.D., and Daniels, M.J.** (1996). Characterization of eds1, a mutation in Arabidopsis suppressing resistance to *Peronospora parasitica* specified by several different RPP genes. *Plant Cell* **8**, 2033-2046.
- Peart, J.R., Mestre, P., Lu, R., Malcuit, I., and Baulcombe, D.C.** (2005). NRG1, a CC-NB-LRR Protein, together with N, a TIR-NB-LRR Protein, Mediates Resistance against Tobacco Mosaic Virus. *Current Biology* **15**, 968-973.
- Philpott, D.J., Sorbara, M.T., Robertson, S.J., Croitoru, K., and Girardin, S.E.** (2014). NOD proteins: regulators of inflammation in health and disease. *Nat Rev Immunol* **14**, 9-23.
- Rietz, S., Stamm, A., Malonek, S., Wagner, S., Becker, D., Medina-Escobar, N., Corina Vlot, A., Feys, B.J., Niefind, K., and Parker, J.E.** (2011). Different roles of Enhanced Disease Susceptibility1 (EDS1) bound to and dissociated from Phytoalexin Deficient4 (PAD4) in Arabidopsis immunity. *New Phytologist* **191**, 107-119.
- Roberts, M., Tang, S., Stallmann, A., Dangl, J.L., and Bonardi, V.** (2013). Genetic Requirements for Signaling from an Autoactive Plant NB-LRR Intracellular Innate Immune Receptor. *PLoS Genet* **9**, e1003465. doi:10.1371/journal.pgen.1003465

- Sarris, Panagiotis F., Duxbury, Z., Huh, Sung U., Ma, Y., Segonzac, C., Sklenar, J., Derbyshire, P., Cevik, V., Rallapalli, G., Saucet, Simon B., Wirthmueller, L., Menke, Frank L.H., Sohn, Kee H., and Jones, Jonathan D.G. (2015). A Plant Immune Receptor Detects Pathogen Effectors that Target WRKY Transcription Factors. *Cell* **161**, 1089-1100.
- Saucet, S.B., Ma, Y., Sarris, P.F., Furzer, O.J., Sohn, K.H., and Jones, J.D.G. (2015). Two linked pairs of Arabidopsis TNL resistance genes independently confer recognition of bacterial effector AvrRps4. *Nat Commun* **6**:6338. doi:10.1038/ncomms7338
- Shao, F., Golstein, C., Ade, J., Stoutemyer, M., Dixon, J.E., and Innes, R.W. (2003). Cleavage of Arabidopsis PBS1 by a Bacterial Type III Effector. *Science* **301**, 1230-1233.
- Shapiguzov, A., Vainonen, J., Wrzaczek, M., and Kangasjärvi, J. (2012). ROS-talk – how the apoplast, the chloroplast and the nucleus get the message through. *Front. Plant Sci.* **3**:292. doi: 10.3389/fpls.2012.00292
- Shen, Q.H., and Schulze-Lefert, P. (2007). Rumble in the nuclear jungle: compartmentalization, trafficking, and nuclear action of plant immune receptors. *EMBO* **26**, 4293-4301.
- Shirasu, K. (2009). The HSP90-SGT1 Chaperone Complex for NLR Immune Sensors. *Annual Review of Plant Biology* **60**, 139-164.
- Slootweg, E., Roosien, J., Spiridon, L.N., Petrescu, A.-J., Tameling, W., Joosten, M., Pomp, R., van Schaik, C., Dees, R., Borst, J.W., Smant, G., Schots, A., Bakker, J., and Goverse, A. (2010). Nucleocytoplasmic Distribution Is Required for Activation of Resistance by the Potato NB-LRR Receptor Rx1 and Is Balanced by Its Functional Domains. *Plant Cell* **22**, 4195-4215.
- Sohn, K.H., Hughes, R.K., Piquerez, S.J., Jones, J.D.G., and Banfield, M.J. (2012). Distinct regions of the *Pseudomonas syringae* coiled-coil effector AvrRps4 are required for activation of immunity. *Proc. Natl. Acad. Sci. USA* **109**, 16371-16376.
- Spoel, S.H., and Dong, X. (2012). How do plants achieve immunity? Defence without specialized immune cells. *Nat Rev Immunol* **12**, 89-100.
- Steinbrener, A.D., Goritschnig, S., and Staskawicz, B.J. (2015). Recognition and Activation Domains Contribute to Allele-Specific Responses of an Arabidopsis NLR Receptor to an Oomycete Effector Protein. *PLoS Pathog* **11**, e1004665. doi:10.1371/journal.ppat.1004665
- Straus, M.R., Rietz, S., Ver Loren van Themaat, E., Bartsch, M., and Parker, J.E. (2010). Salicylic acid antagonism of EDS1-driven cell death is important for immune and oxidative stress responses in Arabidopsis. *Plant J.* **62**, 628-640.
- Takken, F.L., Albrecht, M., and Tameling, W.I. (2006). Resistance proteins: molecular switches of plant defence. *Curr Opin Plant Biol* **9**, 383-390.
- Takken, F.L.W., and Goverse, A. (2012). How to build a pathogen detector: structural basis of NB-LRR function. *Curr Opin Plant Biol* **15**, 375-384.
- Tameling, W.I., Elzinga, S.D., Darmin, P.S., Vossen, J.H., Takken, F.L., Haring, M.A., and Cornelissen, B.J. (2002). The tomato R gene products I-2 and MI-1 are functional ATP binding proteins with ATPase activity. *Plant Cell* **14**, 2929-2939.
- Teh, O.K., and Hofius, D. (2014). Membrane trafficking and autophagy in pathogen-triggered cell death and immunity. *Journal of experimental botany* **65**, 1297-1312.
- Torres, M.A., Dangl, J.L., and Jones, J.D.G. (2002). Arabidopsis gp-91phox homologues AtbohD and AtbohF are required for accumulation of reactive oxygen intermediates in the plant defense response. *Proc. Natl. Acad. Sci. USA* **99**, 517-522.
- van der Hoorn, R.A.L., and Kamoun, S. (2008). From Guard to Decoy: A New Model for Perception of Plant Pathogen Effectors. *Plant Cell* **20**, 2009-2017.
- Vercammen, D., van de Cotte, B., De Jaeger, G., Eeckhout, D., Casteels, P., Vandepoele, K., Vandenberghe, I., Van Beeumen, J., Inzé, D., and Van Breusegem, F. (2004). Type II Metacaspases Atmc4 and Atmc9 of Arabidopsis thaliana Cleave Substrates after Arginine and Lysine. *Journal of Biological Chemistry* **279**, 45329-45336.
- Wagner, S., Stuttmann, J., Rietz, S., Guerois, R., Brunstein, E., Bautor, J., Niefind, K., and Parker, Jane E. (2013). Structural Basis for Signaling by Exclusive EDS1 Heteromeric Complexes with SAG101 or PAD4 in Plant Innate Immunity. *Cell Host & Microbe* **14**, 619-630.
- Williams, S.J., Sohn, K.H., Wan, L., Bernoux, M., Sarris, P.F., Segonzac, C., Ve, T., Ma, Y., Saucet, S.B., Ericsson, D.J., Casey, L.W., Lonhienne, T., Winzor, D.J., Zhang, X., Coerd, A., Parker, J.E., Dodds, P.N., Kobe, B., and Jones, J.D.G. (2014). Structural Basis for Assembly and Function of a Heterodimeric Plant Immune Receptor. *Science* **344**, 299-303.
- Wirthmueller, L., Zhang, Y., Jones, J.D.G., and Parker, J.E. (2007). Nuclear Accumulation of the Arabidopsis Immune Receptor RPS4 Is Necessary for Triggering EDS1-Dependent Defense. *Current Biology* **17**, 2023-2029.
- Wojtaszek, P. (1997). Oxidative burst: An early plant response to pathogen infection. *Biochemical Journal* **322**, 681-692.
- Wu, C.-H., Krasileva, K.V., Banfield, M.J., Terauchi, R., and Kamoun, S. (2015). The “sensor domains” of plant NLR proteins: more than decoys? *Front. Plant Sci.* **6**:134. doi: 10.3389/fpls.2015.00134
- Xing, D., and Chen, Z. (2006). Effects of mutations and constitutive overexpression of EDS1 and PAD4 on plant resistance to different types of microbial pathogens. *Plant Science* **171**, 251-262.
- Xu, F., Cheng, Y.T., Kapos, P., Huang, Y., and Li, X. (2014a). P-loop-dependent NLR SNC1 can oligomerize and activate immunity in the nucleus. *Mol Plant* **7**, 1801-1804.
- Xu, F., Kapos, P., Cheng, Y.T., Li, M., Zhang, Y., and Li, X. (2014b). NLR-Associating Transcription Factor bHLH84 and Its Paralogs Function Redundantly in Plant Immunity. *PLoS Pathog* **10**, e1004312. doi:10.1371/journal.ppat.1004312
- Yano, A., Suzuki, K., and Shinshi, H. (1999). A signaling pathway, independent of the oxidative burst, that leads to hypersensitive cell death in cultured tobacco cells includes a serine protease. *Plant J.* **18**, 105-109.
- Yue, J.-X., Meyers, B.C., Chen, J.-Q., Tian, D., and Yang, S. (2012). Tracing the origin and evolutionary history of plant nucleotide-binding site–leucine-rich repeat (NBS-LRR) genes. *New Phytologist* **193**, 1049-1063.
- Zhang, J., Li, W., Xiang, T., Liu, Z., Laluk, K., Ding, X., Zou, Y., Gao, M., Zhang, X., Chen, S., Mengiste, T., Zhang, Y., and Zhou, J.-M. (2010). Receptor-like Cytoplasmic Kinases Integrate Signaling from Multiple Plant Immune Receptors and Are Targeted by a *Pseudomonas syringae* Effector. *Cell Host & Microbe* **7**, 290-301.
- Zhang, Y., and Li, X. (2005). A Putative Nucleoporin 96 Is Required for Both Basal Defense and Constitutive Resistance Responses Mediated by suppressor of npr1-1, constitutive 1. *Plant Cell* **17**, 1306-1316.
- Zhang, Y., Goritschnig, S., Dong, X., and Li, X. (2003). A Gain-of-Function Mutation in a Plant Disease Resistance Gene Leads to Constitutive Activation of Downstream Signal Transduction Pathways in suppressor of npr1-1, constitutive 1. *Plant Cell* **15**, 2636-2646.
- Zhao, Y., Yang, J., Shi, J., Gong, Y.-N., Lu, Q., Xu, H., Liu, L., and Shao, F. (2011). The NLRC4 inflammasome receptors for bacterial flagellin and type III secretion apparatus. *Nature* **477**, 596-600.
- Zipfel, C. (2014). Plant pattern-recognition receptors. *Trends in Immunology* **35**, 345-351.