

SIEMENS

SIMATIC

S7-400 S7-400 Automation System, CPU Specifications

Manual

<u>Introduction</u>	1
<u>Structure of a CPU 41x</u>	2
<u>Special functions of a CPU 41x</u>	3
<u>Communication</u>	4
<u>PROFIBUS DP</u>	5
<u>PROFINET</u>	6
<u>Consistent Data</u>	7
<u>Memory concept</u>	8
<u>Cycle and Response Times of the S7-400</u>	9
<u>Technical specifications</u>	10
<u>IF 964-DP interface module</u>	11

This manual is part of the documentation package with the order number 6ES7498-8AA05-8BA0

Legal information

Warning notice system

This manual contains notices you have to observe in order to ensure your personal safety, as well as to prevent damage to property. The notices referring to your personal safety are highlighted in the manual by a safety alert symbol, notices referring only to property damage have no safety alert symbol. These notices shown below are graded according to the degree of danger.

⚠ DANGER
indicates that death or severe personal injury will result if proper precautions are not taken.
⚠ WARNING
indicates that death or severe personal injury may result if proper precautions are not taken.
⚠ CAUTION
with a safety alert symbol, indicates that minor personal injury can result if proper precautions are not taken.
CAUTION
without a safety alert symbol, indicates that property damage can result if proper precautions are not taken.
NOTICE
indicates that an unintended result or situation can occur if the corresponding information is not taken into account.

If more than one degree of danger is present, the warning notice representing the highest degree of danger will be used. A notice warning of injury to persons with a safety alert symbol may also include a warning relating to property damage.

Qualified Personnel

The device/system may only be set up and used in conjunction with this documentation. Commissioning and operation of a device/system may only be performed by **qualified personnel**. Within the context of the safety notes in this documentation qualified persons are defined as persons who are authorized to commission, ground and label devices, systems and circuits in accordance with established safety practices and standards.

Proper use of Siemens products

Note the following:

⚠ WARNING
Siemens products may only be used for the applications described in the catalog and in the relevant technical documentation. If products and components from other manufacturers are used, these must be recommended or approved by Siemens. Proper transport, storage, installation, assembly, commissioning, operation and maintenance are required to ensure that the products operate safely and without any problems. The permissible ambient conditions must be adhered to. The information in the relevant documentation must be observed.

Trademarks

All names identified by ® are registered trademarks of the Siemens AG. The remaining trademarks in this publication may be trademarks whose use by third parties for their own purposes could violate the rights of the owner.

Disclaimer of Liability

We have reviewed the contents of this publication to ensure consistency with the hardware and software described. Since variance cannot be precluded entirely, we cannot guarantee full consistency. However, the information in this publication is reviewed regularly and any necessary corrections are included in subsequent editions.

Table of contents

1	Introduction	11
2	Structure of a CPU 41x	15
2.1	Control and display elements of the CPUs	15
2.2	Monitoring functions of the CPU	23
2.3	Status and error displays	26
2.4	Mode selector switch	30
2.4.1	Function of the mode selector switch	30
2.4.2	Running a memory reset.....	32
2.4.3	Cold start / Warm restart / Hot restart.....	34
2.5	Structure and Functions of the Memory Cards	36
2.6	Use of the Memory Cards	38
2.7	Multipoint Interface (MPI).....	41
2.8	PROFIBUS DP Interface.....	43
2.9	PROFINET interface	44
2.10	Overview of the parameters for the S7-400 CPUs	45
3	Special functions of a CPU 41x	47
3.1	Multicomputing	47
3.1.1	Fundamentals	47
3.1.2	Special Features at Multicomputing.....	49
3.1.3	Multicomputing interrupt.....	50
3.1.4	Configuring and programming multicomputing mode	50
3.2	System modifications during operation.....	51
3.2.1	Basics.....	51
3.2.2	Hardware requirements	52
3.2.3	Software requirements.....	53
3.2.4	Permitted system modifications	53
3.3	Resetting the CPU to the factory state	55
3.4	Updating the firmware without a memory card	57
3.5	Reading out service data	59

4	Communication.....	61
4.1	interfaces.....	61
4.1.1	Multi-Point Interface (MPI)	61
4.1.2	PROFIBUS DP	63
4.1.3	PROFINET	65
4.2	Communication services.....	67
4.2.1	Overview of communication services.....	67
4.2.2	PG communication.....	69
4.2.3	OP communication.....	69
4.2.4	S7 basic communication	70
4.2.5	S7 communication.....	71
4.2.6	Global data communication.....	73
4.2.7	S7 routing.....	74
4.2.8	Time synchronization	79
4.2.9	Data set routing.....	80
4.3	SNMP network protocol	82
4.4	Open Communication Via Industrial Ethernet.....	83
4.5	S7 connections.....	87
4.5.1	Communication path of an S7 connection	87
4.5.2	Assignment of S7 connections.....	88
4.6	Communication performance.....	90
4.7	Web server	93
4.7.1	Properties of the web server	93
4.7.2	Settings in HW Config, "Web" tab.....	97
4.7.3	Language settings.....	100
4.7.4	Updating and saving information	102
4.7.5	Web pages	104
4.7.5.1	Start page with general CPU information.....	104
4.7.5.2	Identification	106
4.7.5.3	Diagnostics buffer	107
4.7.5.4	Module state.....	109
4.7.5.5	Alarms	114
4.7.5.6	Communication	116
4.7.5.7	Topology.....	119
4.7.5.8	Examples of individual topology views.....	126
4.7.5.9	Variable status	131
4.7.5.10	Variable tables	133
5	PROFIBUS DP	135
5.1	CPU 41x as DP master / DP slave	135
5.1.1	Overview	135
5.1.2	DP address areas of 41x CPUs	136
5.1.3	CPU 41x as PROFIBUS DP master	137
5.1.4	Diagnostics of the CPU 41x as DP master	141
5.1.5	CPU 41x as DP slave.....	146
5.1.6	Diagnostics of the CPU 41x as DP slave.....	151
5.1.7	CPU 41x as DP slave: Station statuses 1 to 3.....	156
5.1.8	Direct Data Exchange	162
5.1.8.1	Principle of direct data exchange.....	162
5.1.8.2	Diagnostics in direct data exchange	163
5.1.9	Isochrone mode	165

6	PROFINET	169
6.1	Introduction	169
6.2	PROFINET IO and PROFINET CBA	170
6.3	PROFINET IO Systems	172
6.4	Blocks in PROFINET IO.....	174
6.5	System status lists for PROFINET IO	177
7	Consistent Data	179
7.1	Basics.....	179
7.2	Consistency for communication blocks and functions	180
7.3	Consistent Reading and Writing of Data from and to DP Standard Slaves/IO Devices	181
8	Memory concept	185
8.1	Overview of the memory concept of S7-400 CPUs	185
9	Cycle and Response Times of the S7-400	189
9.1	Cycle time	189
9.2	Cycle Time Calculation	191
9.3	Different cycle times.....	194
9.4	Communication Load	196
9.5	Reaction Time	199
9.6	Calculating cycle and reaction times	205
9.7	Examples of Calculating the Cycle Time and Reaction Time.....	206
9.8	Interrupt Reaction Time	209
9.9	Example: Calculating the Interrupt Reaction Time	211
9.10	Reproducibility of Time-Delay and Watchdog Interrupts	212
9.11	CBA response times	213
10	Technical specifications	217
10.1	Specifications of the CPU 412-1 (6ES7412-1XJ05-0AB0)	217
10.2	Specifications of the CPU 412-2 (6ES7412-2XJ05-0AB0)	225
10.3	Specifications of the CPU 414-2 (6ES7414-2XK05-0AB0)	233
10.4	Specifications of the CPU 414-3 (6ES7414-3XM05-0AB0).....	241
10.5	Specifications of the CPU 414-3 PN/DP (6ES7414-3EM05-0AB0).....	250
10.6	Specifications for the CPU 416-2 (6ES7416-2XN05-0AB0), CPU 416F-2 (6ES7416-2FN05-0AB0)	262
10.7	Specifications of the CPU 416-3 (6ES7416-3XR05-0AB0)	270
10.8	Specifications of the CPU 416-3 PN/DP (6ES7416-3ER05-0AB0), CPU 416F-3 PN/DP (6ES7416-3FR05-0AB0).....	279
10.9	Specifications of the CPU 417-4 (6ES7417-4XT05-0AB0).....	291
10.10	Technical specifications of the memory cards	300

11	IF 964-DP interface module	301
11.1	Using the IF 964-DP interface module	301
11.2	Technical specifications	303
	Index	305

Tables

Table 2- 1	LEDs on the CPUs.....	20
Table 2- 2	Malfunctions and CPU responses.....	23
Table 2- 3	Possible states of the RUN and STOP LEDs	26
Table 2- 4	Possible states of the INTF, EXTF and FRCE LEDs.....	27
Table 2- 5	Possible states of the BUS1F, BUS2F und BUS5F LEDs.....	27
Table 2- 6	Possible states of the IFM1F and IFM2F LEDs.....	28
Table 2- 7	Possible states of the LINK and RX/TX LEDs	28
Table 2- 8	Mode selector switch settings	30
Table 2- 9	Security classes of an S7-400 CPU.....	31
Table 2- 10	MPI parameters and IP address following memory reset.....	33
Table 2- 11	Types of Memory Card	38
Table 3- 1	CPU properties in the factory settings	55
Table 3- 2	LED patterns	56
Table 4- 1	Communication services of the CPUs	67
Table 4- 2	Availability of connection resources.....	68
Table 4- 3	SFCs for S7 Basic Communication	70
Table 4- 4	SFBs for S7 Communication.....	72
Table 4- 5	SFCs for Global Data Communication.....	73
Table 4- 6	Job lengths and "local_device_id" parameter	85
Table 5- 1	41x CPUs (MPI/DP interface as PROFIBUS DP).....	136
Table 5- 2	41x CPUs (MPI/DP interface and DP module as PROFIBUS DP).....	136
Table 5- 3	Meaning of the "BUSF" LED of the CPU 41x as DP master	141
Table 5- 4	Reading the diagnostic data with STEP 7	142
Table 5- 5	Diagnostic addresses for the DP master and DP slave.....	144
Table 5- 6	Event detection of the CPUs 41x as DP master.....	144
Table 5- 7	Evaluation of RUN-STOP transitions of the DP slave in the DP master	145
Table 5- 8	Configuration example for the address areas of the transfer memory	147
Table 5- 9	Meaning of the "BUSF" LEDs of the CPU 41x as DP slave	151
Table 5- 10	Reading the diagnostics data with STEP 5 and STEP 7 in the master system.....	152
Table 5- 11	STEP 5 user program	153
Table 5- 12	Diagnostics addresses for the DP master and DP slave.....	153
Table 5- 13	Event detection of the CPUs 41x as DP slave.....	154
Table 5- 14	Evaluating RUNSTOP transitions in the DP master/DP slave.....	154
Table 5- 15	Structure of station status 1 (Byte 0)	156
Table 5- 16	Structure of station status 2 (Byte 1)	156

Table 5- 17	Structure of station status 3 (Byte 2).....	157
Table 5- 18	Structure of the master PROFIBUS address (byte 3).....	157
Table 5- 19	Diagnostic address for the recipient during direct data exchange.....	163
Table 5- 20	Event detection by the 41x CPUs as recipients during direct communication.....	163
Table 5- 21	Evaluation of the station failure in the sender during direct data exchange	164
Table 6- 1	New System and Standard Functions/System and Standard Functions to be Replaced.....	174
Table 6- 2	System and Standard Functions in PROFIBUS DP that must be Implemented with Different Functions in PROFINET IO	175
Table 6- 3	OBs in PROFINET IO and PROFIBUS DP.....	176
Table 6- 4	Comparison of the system status lists of PROFINET IO and PROFIBUS DP.....	177
Table 8- 1	Memory requirements	187
Table 9- 1	Cyclic program processing.....	189
Table 9- 2	Factors that Influence the Cycle Time	191
Table 9- 3	Portions of the process image transfer time	192
Table 9- 4	Operating System Scan Time at the Scan Cycle Checkpoint.....	193
Table 9- 5	Increase in cycle time by nesting interrupts.....	193
Table 9- 6	Reducing the response time	203
Table 9- 7	Example of Calculating the Response Time.....	205
Table 9- 8	Calculating the Interrupt Response Time.....	209
Table 9- 9	Hardware Interrupt and Diagnostic Interrupt Response Times; Maximum Interrupt Response Time Without Communication.....	209
Table 9- 10	Reproducibility of Time-Delay and Watchdog Interrupts of the CPUs.....	212
Table 9- 11	Response time for acyclic interconnections.....	216

Figures

Figure 2-1	Arrangement of the control and display elements on CPU 412-1	15
Figure 2-2	Arrangement of the control and display elements on CPU 41x-2.....	16
Figure 2-3	Arrangement of the control and display elements on CPU 41x-3.....	17
Figure 2-4	Arrangement of the control and display elements on CPU 41x-3PN/DP	18
Figure 2-5	Arrangement of the control and display elements on CPU 417-4	19
Figure 2-6	Cable with jack plug	22
Figure 2-7	Mode selector switch settings	30
Figure 2-8	Design of the Memory Card.....	36
Figure 3-1	Example of multicomputing.....	48
Figure 3-2	Overview: System structure for system modifications in run	51
Figure 4-1	S7 routing.....	75
Figure 4-2	S7 routing gateways: MPI - DP - PROFINET	76
Figure 4-3	S7 routing: TeleService application example.....	77
Figure 4-4	Data set routing.....	81
Figure 4-5	Communication load as a function of data throughput and response time (basic profile).....	90
Figure 4-6	Settings in HW Config.....	97
Figure 4-7	Example for selecting the display device language	101
Figure 4-8	Intro	104
Figure 4-9	General Information	105
Figure 4-10	Identification	106
Figure 4-11	Diagnostics buffer	107
Figure 4-12	Module state.....	110
Figure 4-13	Module state.....	112
Figure 4-14	Messages.....	114
Figure 4-15	Parameters of the integrated PROFINET interface	116
Figure 4-16	Data transfer numbers	118
Figure 4-17	Topology - Graphical view	120
Figure 4-18	Topology - Tabular view.....	123
Figure 4-19	Topology - Status overview.....	125
Figure 4-20	"Actual topology" is OK	126
Figure 4-21	"Saved topology" is OK.....	127
Figure 4-22	"Saved topology" with failed device	128
Figure 4-23	"Saved topology" of a failed, non-configured device.	129
Figure 4-24	"Actual topology" with failed device	130
Figure 4-25	Variable status	131

Figure 4-26	Variable tables	133
Figure 5-1	Diagnostics with CPU 41x.....	143
Figure 5-2	Transfer memory in the CPU 41x as DP slave	147
Figure 5-3	Structure of slave diagnostics	155
Figure 5-4	Structure of the ID-related diagnostic data of the CPU 41x.....	158
Figure 5-5	Structure of the device-related diagnostics.....	159
Figure 5-6	Bytes x +4 to x +7 for diagnostic and hardware interrupts.....	160
Figure 5-7	Direct data exchange with 41x CPUs	162
Figure 5-8	Isochronous data processing	165
Figure 5-9	Just-In-Time	166
Figure 5-10	System cycle	167
Figure 6-1	PROFINET IO and PROFINET CBA	171
Figure 6-2	PROFINET IO	172
Figure 8-1	Memory areas of S7-400 CPUs	185
Figure 9-1	Parts and Composition of the Cycle Time.....	190
Figure 9-2	Different cycle times.....	194
Figure 9-3	Minimum cycle time.....	195
Figure 9-4	Equation: Influence of communication load	196
Figure 9-5	Breakdown of a time slice	197
Figure 9-6	Dependency of the Cycle Time on the Communication load.....	198
Figure 9-7	DP cycle times on the PROFIBUS DP network	200
Figure 9-8	Update cycle	201
Figure 9-9	Shortest response time	201
Figure 9-10	Longest response time.....	202
Figure 9-11	Processing time for sending and receiving	214
Figure 11-1	IF 964-DP interface module	301

Introduction

Purpose of the manual

The information provided in this manual can be used as a reference relating to the controls, to the description of functions, and to the technical specifications of the CPUs of the S7-400 product range.

Information on how to install an S7-400 system which contains those and additional modules is provided in the *S7-400 Automation System; Hardware and Installation* manual.

Changes compared to the previous versions

This revision of the S7-400 Automation System; CPU Specifications manual, Edition 09/2008 (A5E00850745-06), contains the following changes compared to the previous version:

- The CPU firmware has been updated to version 5.3.
- Enhanced system diagnostics of the internal and external PROFINET interface: Overview and detailed diagnostics of connections for "open communication over Industrial Ethernet", STEP 7 V5.4 SP5 or higher.
- Extension of the Webserver functionality of (CPU 41x-3 PN/DP): as of STEP 7 V5.4 SP5.

Basic knowledge required

Comprehension of this manual requires general knowledge in the field of automation technology.

Users should also have sufficient knowledge of computers, or of tools similar to PCs (e.g., programming devices), and of the Windows XP or Vista operating system. As the S7-400 is configured using the STEP 7 basic software, you should also have sufficient knowledge of handling the basic software. This knowledge is provided in the *Programming with STEP 7* manual.

Particularly when using an S7-400 in safety-relevant areas you should observe the information with regard to the safety of electronic controllers in the appendix of the *S7-400 Automation system; Hardware and Installation* manual.

Scope of the manual

The manual applies to the CPUs listed below:

- CPU 412-1, V5.3; 6ES7 412-1XJ05-0AB0
- CPU 412-2, V5.3; 6ES7-412-2XJ05-0AB0
- CPU 414-2, V5.3; 6ES7 414-2XK05-0AB0
- CPU 414-3, V5.3; 6ES7 414-3XM05-0AB0
- CPU 414-3 PN/DP, V5.3; 6ES7 414-3EM05-0AB0
- CPU 416-2, V5.3; 6ES7 416-2XN05-0AB0
- CPU 416F-2, V5.3; 6ES7 416-2FN05-0AB0
- CPU 416-3, V5.3; 6ES7 416-3XR05-0AB0
- CPU 416-3 PN/DP, V5.3; 6ES7 416-3ER05-0AB0
- CPU 416F-3 PN/DP, V5.3; 6ES7 416-3FR05-0AB0
- CPU 417-4, V5.3; 6ES7 417-4XT05-0AB0

General technical specifications

Information pertaining to approvals and standards is available in the *S7-400 Automation System; Module Data* manual.

Scope of information

This manual is part of the S7-400 documentation package.

System	Documentation package
S7-400	<ul style="list-style-type: none">• S7-400 Automation System; Hardware and Installation• S7-400 Automation Systems; Module Data• S7-400 Instruction List• S7-400 Automation System; CPU Specifications

Additional information

The following manuals provide more information relating to the topics in this manual:

Programming with STEP 7 (<http://support.automation.siemens.com/WW/view/en/18652056>)

Configuring Hardware and Communication Connections with STEP 7
(<http://support.automation.siemens.com/WW/view/en/18652631>)

System and Standard Functions
(<http://support.automation.siemens.com/WW/view/en/1214574>)

PROFINET system description
(<http://support.automation.siemens.com/WW/view/en/19292127>)

Isochrone mode (<http://support.automation.siemens.com/WW/view/en/15218045>)

Recycling and disposal

The S7-400 system can be recycled due to its low-pollutant equipment. For ecologically compatible recycling and disposal of your old device, contact a certified disposal service for electronic scrap.

Additional support

Contact your Siemens partner at your local office or agencies if you have any questions relating to the product and do not find the right answers in this manual.

You will find your contact partner at:

Contact partners (<http://www.siemens.com/automation/partner>)

A guide to the technical documentation for the various SIMATIC products and systems is available at:

Documentation (http://www.automation.siemens.com/simatic/portal/html_76/techdoku.htm)

The online catalog and online ordering system are available at:

Catalog (<http://mall.automation.siemens.com/>)

Training Centers

Siemens offers corresponding courses to get you started with the SIMATIC S7 automation system. Contact your regional Training Center, or the central Training Center in D-90327 Nuremberg, Germany:

Training (http://www.sitrain.com/index_en.html)

Technical Support

You can contact Technical Support for all Industry Automation products using the Web form for Support Request

Support Request (<http://www.siemens.de/automation/support-request>)

Additional information about Siemens Technical Support is available on the Internet at Technical Support (<http://support.automation.siemens.com>)

Service & Support on the Internet

In addition to the documentation, Siemens offers a comprehensive online knowledge base on the Internet at:

Service & Support (<http://www.siemens.com/automation/service&support>)

There you will find:

- The newsletter that provides the latest information about your products.
- The current documentation using the Search function on the Service & Support pages.
- An international forum where users and specialists can exchange their experience.
- Your local contact partner for automation and drive technology in our contacts database.
- Information about on-site services, repairs and spare parts. Lots more is available on the "Services" pages.
- Applications and tools for optimizing operations with SIMATIC S7. The forum is also used to publish items such as the results of DP and PN performance measurements.

Structure of a CPU 41x

2.1 Control and display elements of the CPUs

Control and display elements of CPU 412-1

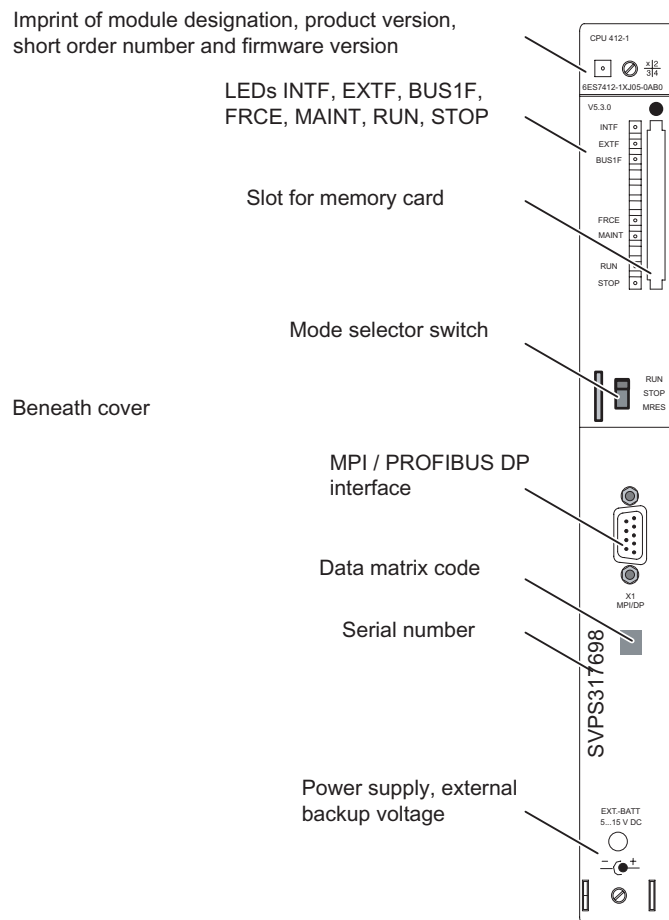

Figure 2-1 Arrangement of the control and display elements on CPU 412-1

Control and display elements of CPU 41x-2

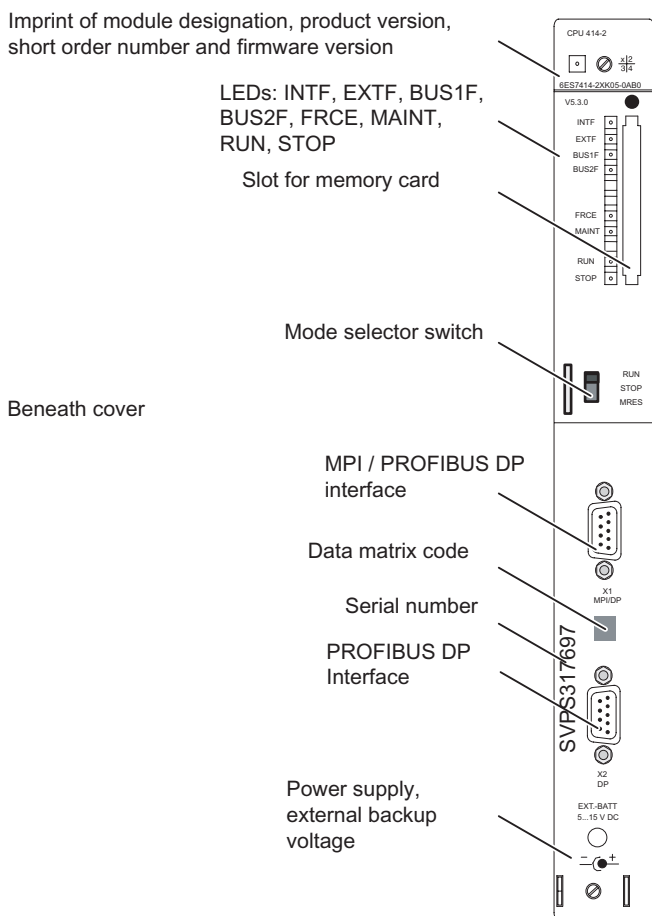

Figure 2-2 Arrangement of the control and display elements on CPU 41x-2

Control and display elements of CPU 41x-3

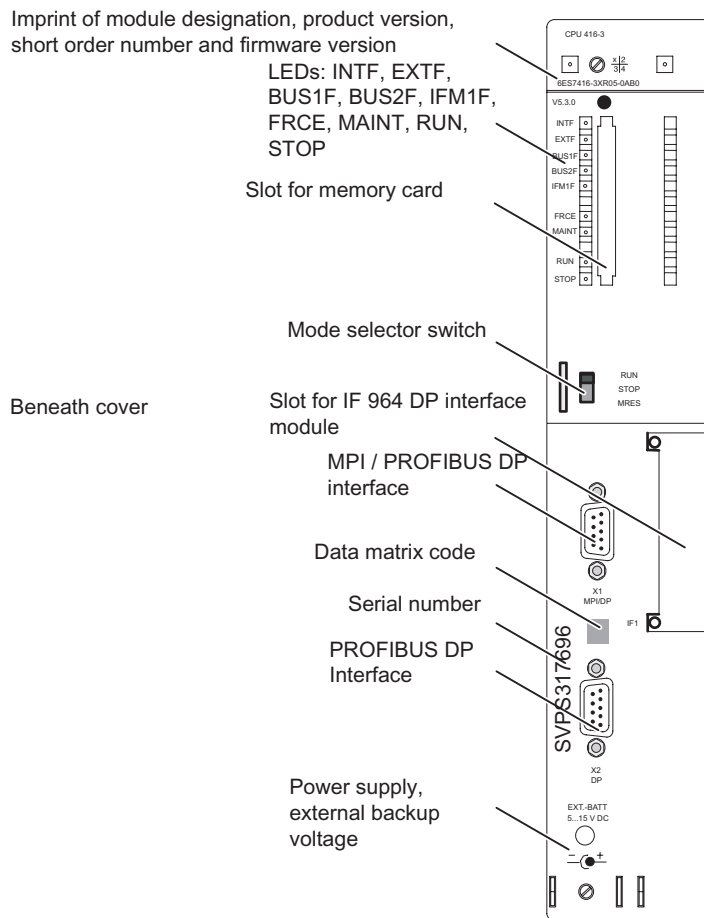

Figure 2-3 Arrangement of the control and display elements on CPU 41x-3

Control and display element of CPU 41x-3PN/DP

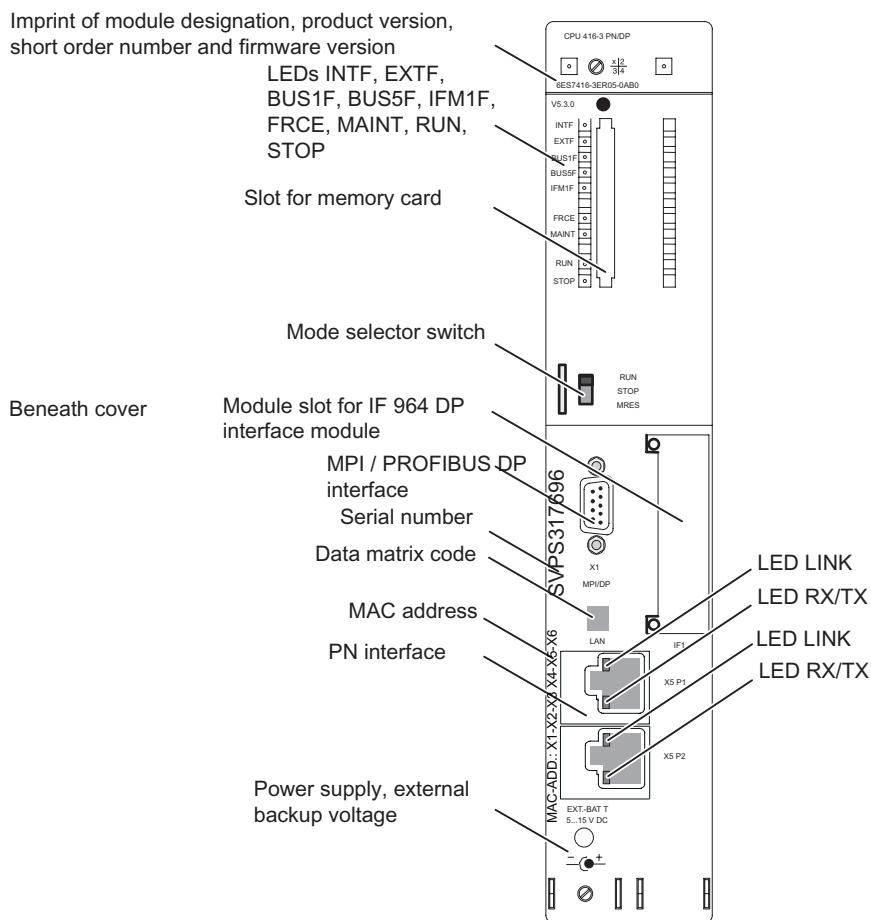

Figure 2-4 Arrangement of the control and display elements on CPU 41x-3PN/DP

Control and display elements of CPU 417-4

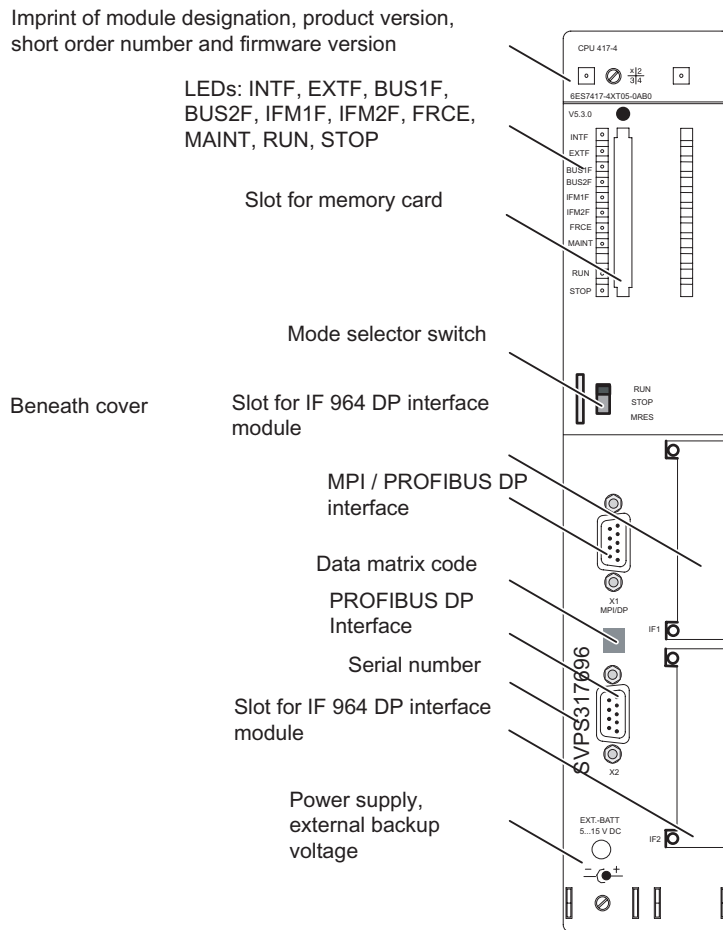

Figure 2-5 Arrangement of the control and display elements on CPU 417-4

LEDs

The table below provides an overview of the LEDs on the specific CPUs.

Table 2- 1 LEDs on the CPUs

LED	Color	Meaning	Installed on CPU				
			412-1	412-2 414-2 416-2 416F-2	414-3 416-3	414-3 PN/DP 416-3 PN/DP 416F-3 PN/DP	417-4
INTF	red	Internal fault	X	X	X	X	X
EXTF	red	External fault	X	X	X	X	X
FRCE	yellow	Force command active	X	X	X	X	X
MAINT	yellow	Maintenance request pending	X	X	X	X	X
RUN	green	RUN mode	X	X	X	X	X
STOP	yellow	STOP mode	X	X	X	X	X
BUS1F	red	Bus fault at MPI/PROFIBUS DP interface 1	X	X	X	X	X
BUS2F	red	Bus fault at PROFIBUS DP interface 2	-	X	X	-	X
BUS5F	red	Bus fault at the PROFINET interface	-	-	-	X	-
IFM1F	red	Fault at interface module 1	-	-	X	X	X
IFM2F	red	Fault at interface module 2	-	-	-	-	X

Note

BUS5F LED

On 41x-3PN/DP CPUs, the BUS5F LED is named BUS2F LED in the module state and module object properties in STEP 7 diagnostics.

Mode switch

You can use the mode switch to set the current operating mode of the CPU. The mode switch is a toggle switch with three positions.

Memory card slot

You can insert a memory card into this slot.

There are two types of memory card:

- RAM cards

You can expand CPU load memory using the RAM card.

- Flash cards

The FLASH card can be used as non-volatile medium for storing the user program and data (no backup battery necessary). The FLASH card can be programmed either on the programming device, or on the CPU. The FLASH card also expands load memory of the CPU.

Slot for interface modules

This slot can receive one PROFIBUS DP module IF 964-DP on CPUs 41x-3 and 417-4, order number 6ES7964-2AA04-0AB0.

MPI/DP interface

The following devices can be connected to the MPI interface of the CPU, for example:

- Programming devices
- Operator control and monitoring devices
- Other S7-400 or S7-300 controllers

Use the bus connector with angled cable outlet; see the *S7-400 Automation System, Hardware and Installation* manual.

You can also configure the MPI interface for operation in DP master mode so that you can use it as PROFIBUS DP interface with up to 32 DP slaves.

PROFIBUS DP Interface

You can connect the distributed I/O, programming devices/OPs and other DP master stations to the PROFIBUS DP interface.

PROFINET interface

You can connect PROFINET IO devices to the PROFINET interface. The PROFINET interface features two switched ports with external connectors (RJ 45). The PROFINET interface provides the interconnection with Industrial Ethernet.

CAUTION

This interface only allows connection to an Ethernet LAN. You cannot connect it to the public telecommunication network, for example.

You may only connect PROFINET-compliant network components to this interface.

Power input, external backup voltage at the "EXT.-BATT." socket

You can install one or two backup batteries in the S7-400 power supply modules, depending on the module type, to achieve the following result:

- Backup of a user program you saved to RAM.
- You are storing bit memories, timers, counters, system data and data in dynamic DBs.
- You backup the internal clock.

The same backup function can be achieved by applying a voltage of from 5 VDC to 15 VDC to the "EXT.-BATT." jack of the CPU.

The "EXT.-BATT." input has the following features:

- Polarity reversal protection
- Short-circuit current limiting to 20 mA

You need a cable with 2.5 mm Ø jack plug to connect the power supply to the "EXT.-BATT" socket as shown in the following illustration. Make sure the polarity of the jack plug is correct.

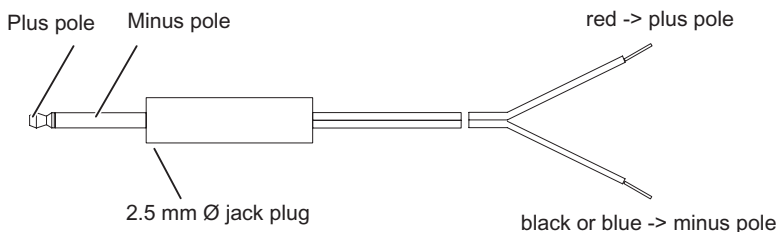

Figure 2-6 Cable with jack plug

You can order a patch cable with jack plug under order number A5E00728552A.

Note

If replacing a power supply module you must connect an external power supply to the "EXT.-BATT." jack in order to backup the user program and the data mentioned above stored in RAM.

Do not connect the cables of various CPUs with each other. Connecting the cables of different CPUs with each other can lead to problems with regard to EMC conditions and different voltage potentials.

See also

Monitoring functions of the CPU (Page 23)

Status and error displays (Page 26)

Multipoint Interface (MPI) (Page 41)

2.2 Monitoring functions of the CPU

Monitoring functions and error messages

The CPU hardware and the operating system provide monitoring functions to ensure proper functioning of the system and a defined response to malfunction. Certain error events can also trigger a response from the user program. With intermittent errors, the LED goes dark again after the next incoming error.

The table below provides an overview of the possible errors, their causes and the responses of the CPU.

Table 2- 2 Malfunctions and CPU responses

Type of error	Cause of error	Response of the operating system	Error LED
Loss of clock signal (incoming)	When using isochronous mode:: clock pulses were lost either because OB61...64 was not started due to higher priorities, or because additional asynchronous bus loads have suppressed the bus clock.	OB 80 call If the OB was not loaded: The CPU goes into STOP OB 61..64 called at the next clock cycle.	INTF
Timeout error (incoming)	<ul style="list-style-type: none"> User program runtime (OB1 and all interrupt and error OBs) exceeds the specified maximum cycle time. OB request error Overflow of the startup information buffer Watchdog interrupt Resume RUN after CiR 	The "INTF" LED stays lit until the error is acknowledged. OB 80 call If the OB was not loaded: The CPU goes into STOP	INTF
Failure of the power supply module(s), (no power failer), (incoming and outgoing)	In the central or expansion rack <ul style="list-style-type: none"> At least one backup battery of the power supply module is discharged Missing backup voltage The 24 VDC supply from the power supply module has failed 	OB 81 call If the OB was not loaded: The CPU remains in RUN.	EXTF
Diagnostics interrupt (incoming and outgoing)	An I/O module with interrupt capability reports a diagnostics interrupt	OB 82 call If the OB was not loaded: The CPU goes into STOP	EXTF
Maintenance request (incoming and outgoing)	Maintenance requests initiate a diagnostics interrupt	OB 82 call If the OB was not loaded: The CPU goes into STOP	EXTF, MAINT
Remove/insertion interrupt (incoming and outgoing)	Removal or insertion of an SM, or insertion of the incorrect module type. The EXTF LED does not light up if only one SM is inserted and then removed while the CPU is in STOP (default parameterization). The LED lights up briefly after the SM was reinserted.	OB 83 call If the OB was not loaded: The CPU goes into STOP	EXTF
CPU hardware error (incoming)	<ul style="list-style-type: none"> A memory error was detected and eliminated 	OB 84 call If the OB was not loaded: The CPU remains in RUN.	INTF

2.2 Monitoring functions of the CPU

Type of error	Cause of error	Response of the operating system	Error LED
Priority class error (incoming only, or incoming and outgoing, depending on OB 85 mode)	<ul style="list-style-type: none"> • A priority class is called, but the corresponding OB is not available. • For an SFB call: The instance DB is missing or faulty. • Error while updating the process image 	OB 85 call If the OB was not loaded: The CPU goes into STOP	INTF EXTF
Rack / station failure (incoming and outgoing)	<ul style="list-style-type: none"> • Power failure at an expansion rack • Failure of a PROFIBUS DP segment • Failure of a PROFINET IO subsystem • Failure of a coupling segment: Missing or defective IM, cable break) 	OB 86 call If the OB was not loaded: The CPU goes into STOP	EXTF
Communication error (incoming)	<ul style="list-style-type: none"> • Status information cannot be written to the DB (global data communication) • Incorrect message frame ID (global data communication) • Incorrect message frame length (global data communication) • Error in structure of global data frame (global data communication) • DB access error 	OB 87 call If the OB was not loaded: The CPU goes into STOP	INTF
Execution aborted (incoming)	<ul style="list-style-type: none"> • Synchronizing error with nesting depth exceeded • Too many nested block calls (B stack) • Error while allocating local data 	OB 88 call If the OB was not loaded: The CPU goes into STOP	INTF
Programming error (incoming)	Error in user program: <ul style="list-style-type: none"> • BCD conversion error • Range length error • Range error • Alignment error • Write error • Timer number error • Counter number error • Block number error • Block not loaded 	OB 121 call If the OB was not loaded: The CPU goes into STOP	INTF

Type of error	Cause of error	Response of the operating system	Error LED
Code error (incoming)	Error in the compiled user program (for example, invalid OP code, or jump beyond block end)	The CPU goes into STOP CPU restart or memory reset required.	INTF
Access error (incoming)	Module failure (SM, FM, CP) I/O read access error I/O write access error	The "EXTF" LED stays lit until the error is acknowledged. For SMs: <ul style="list-style-type: none"> • OB 122 call • Entry in the diagnostics buffer • For input modules: "NULL" entered as data in the accumulator or in the process image For other modules: <ul style="list-style-type: none"> • OB 122 call If the OB was not loaded: The CPU goes into STOP	EXTF

Additional test and reporting functions are available in each CPU and can be called in STEP 7.

2.3 Status and error displays

Status LEDs

The RUN and STOP LEDs on the front panel of the CPU indicate the current CPU mode.

Table 2- 3 Possible states of the RUN and STOP LEDs

LED		Meaning
RUN	STOP	
H	D	CPU is in RUN mode.
D	H	CPU is in STOP mode. The user program is not executed. Cold restart, restart and warm restart/reboot are possible. If STOP was triggered by an error, the error LED (INTF or EXTf) is also set.
B 2 Hz	B 2 Hz	CPU is DEFECTIVE. The INTF, EXTf, FRCE, BUSF1, BUSF5 and IFM1F LEDs also flash.
B 0.5 Hz	H	CPU HOLD was triggered by a test function.
B 2 Hz	H	A warm restart / cold restart / hot restart was triggered. It can take a minute or more to execute those functions, depending on the length of the OB called. If the CPU still does not go into RUN there might be an error in the system configuration.
x	B 0.5 Hz	The CPU requests a memory reset.
x	B 2 Hz	Memory reset in progress, or the CPU is currently being initialized after POWER ON.
D = LED is dark; H = LED is lit; B = LED flashes at the specified frequency; x = LED status is irrelevant		

Error displays and special features

The three LEDs INTF, EXTF and FRCE on the front panel of the CPU indicate errors and special features in user program runtime.

Table 2- 4 Possible states of the INTF, EXTF and FRCE LEDs

LED			Meaning
INTF	EXTF	FRCE	
H	x	x	An internal error was detected (programming or parameterizing error), or the CPU is currently performing a CiR.
x	H	x	An external error was detected, that is, the cause of error is not on the CPU module.
x	x	H	A force command is active.
x	x	B 2 Hz	Node flash test function.
D = LED is dark; H = LED is lit; B = LED flashes at the specified frequency; x = LED status is irrelevant			

The LEDs BUS1F, BUS2F and BUS5F indicate errors associated with the MPI/DP, PROFIBUS DP and PROFINET IO interfaces.

Table 2- 5 Possible states of the BUS1F, BUS2F und BUS5F LEDs

LED			Meaning	
BUS1F	BUS2F	BUS5F		
H	x	x	An error was detected at the MPI/DP interface.	
x	H	x	An error was detected on the PROFIBUS DP interface.	
x	x	H	An error was detected at the PROFINET IO interface. A PROFINET IO system is configured but not connected.	
x	x	B	One or several devices on the PROFINET IO interface are not responding.	
B	x	x	CPU is DP master:	One or several devices on PROFIBUS DP interface 1 are not responding.
			CPU is DP slave:	CPU is not addressed by the DP master.
x	B	x	CPU is DP master:	One or several devices on PROFIBUS DP interface 2 are not responding.
			CPU is DP slave:	CPU is not addressed by the DP master.
H = LED is lit; B = LED flashes; x = LED status has no relevance				

Error displays and special features, CPU 41x-3, CPU 41x-3 PN/DP und 417-4

The CPUs 41x-3, 41x-3 PN/DP and 417-4 are equipped with the IFM1F LED, or with the IFM1F and IFM2F LEDs. These LEDs indicate problems associated with the module interface.

Table 2- 6 Possible states of the IFM1F and IFM2F LEDs

LED		Meaning	
IFM1F	IFM2F		
H	x	An error was detected at module interface 1.	
x	H	An error was detected at module interface 2.	
B	x	CPU is DP master:	One or several slaves connected to PROFIBUS DP interface at module slot 1 are not responding.
		CPU is DP slave:	CPU is not addressed by the DP master.
x	B	CPU is DP master:	One or several slaves connected to the PROFIBUS DP interface at module slot 2 are not responding.
		CPU is DP slave:	CPU is not addressed by the DP master.
H = LED is lit; B = LED flashes; x = LED status has no relevance			

Error displays and special features of CPU 41x-3 PN/DP

The CPUs 41x-3 PN/DP also have a LINK LED and an RX/TX LED Those LEDs indicate the current state of the PROFINET interface.

Table 2- 7 Possible states of the LINK and RX/TX LEDs

LED		Meaning
LINK	RX/TX	
H	x	Connection at PROFINET interface is active
x	B 6 Hz	Receiving or sending data at the PROFINET interface.
H = LED is lit; B = LED flashes at the specified frequency; x = LED status is irrelevant		

Note

The LINK and RX/TX LEDs are located directly next to the jacks of the PROFINET interface. They are not labeled.

LED MAINT

This LED indicates an active maintenance request. For additional information, refer to the STEP 7 Online Help. Up to firmware version V 5.1 the Maint LED indicates both an active maintenance request and maintenance requirement. As of firmware version V 5.2 the Maint LED only indicates an active maintenance requirement

Diagnostics buffer

In STEP 7 you can troubleshoot an error by selecting "PLC -> Module status" in order to read the cause of an error from the diagnostics buffer.

2.4 Mode selector switch

2.4.1 Function of the mode selector switch

Overview

The mode selector is used to switch the CPU from RUN to STOP or to reset the CPU memory. STEP 7 offers additional mode selection options.

Positions

The mode selector is designed as a toggle switch. The following figure shows all the positions of the mode selector.

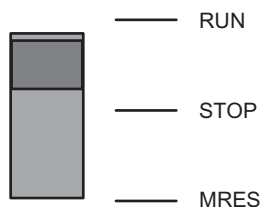

Figure 2-7 Mode selector switch settings

The following table explains the settings of the mode selector switch. In the event of an error or if there are problems preventing startup, the CPU switches to or remains in STOP mode, regardless of the position of the mode selector.

Table 2- 8 Mode selector switch settings

Position	Notes
RUN	If there is no startup problem or error and the CPU was able to switch to RUN, the CPU either runs the user program or remains idle. The I/O can be accessed. <ul style="list-style-type: none"> You can upload programs from the CPU to the programming device (CPU -> Programming device) You can upload programs from the programming device to the CPU (Programming device -> CPU).
STOP	The CPU does not execute the user program. The digital signal modules are locked. The output modules are disabled in the default parameter settings. <ul style="list-style-type: none"> You can upload programs from the CPU to the programming device (CPU -> Programming device) You can upload programs from the programming device to the CPU (Programming device -> CPU).
MRES (CPU memory reset; master reset)	Toggle switch position for general reset of the CPU memory, see section Running a memory reset (Page 32). Toggle switch position for the "Reset CPU to factory state" function, see section Resetting the CPU to the factory state (Page 55)

Security classes

A security class can be agreed for S7-400 CPUs in order to prevent unauthorized access to CPU programs. You can define a security class which allows users to access PG functions without particular authorization (password) on the CPU concerned. All PG functions can be accessed if a password is entered.

Setting the security classes

You can set the security classes (1 to 3) for a CPU in STEP 7 -> HW Config.

You can delete the the security class set STEP 7 -> HW Config by means of a manual reset using the mode selector switch.

The following table lists the security classes of an S7-400 CPU.

Table 2- 9 Security classes of an S7-400 CPU

CPU function	Security class 1	Security class 2	Security class 3
Block list displays	Access allowed	Access allowed	Access allowed
Monitoring Variables	Access allowed	Access allowed	Access allowed
STACKS module status	Access allowed	Access allowed	Access allowed
Operator control and monitoring functions	Access allowed	Access allowed	Access allowed
S7 communication	Access allowed	Access allowed	Access allowed
Read time of day	Access allowed	Access allowed	Access allowed
Set time of day	Access allowed	Access allowed	Access allowed
Block status	Access allowed	Access allowed	Password required
Download to programming device	Access allowed	Access allowed	Password required
Download to CPU	Access allowed	Password required	Password required
Delete blocks	Access allowed	Password required	Password required
Compress memory	Access allowed	Password required	Password required
Download user program to memory card	Access allowed	Password required	Password required
Modify selection	Access allowed	Password required	Password required
Modify variable	Access allowed	Password required	Password required
Breakpoint	Access allowed	Password required	Password required
Exit break	Access allowed	Password required	Password required
Memory reset	Access allowed	Password required	Password required
Force	Access allowed	Password required	Password required

Setting the security class with SFC 109 "PROTECT"

SFC 109 "PROTECT" is used to switch between security classes 1 and 2.

2.4.2 Running a memory reset

Operating sequence at memory reset

Case A: You want to transfer a new, complete user program to the CPU.

1. Set the mode selector switch to STOP.

Result: The STOP LED is lit.

2. Set the selector to MRES and hold it there.

Result: The STOP LED is switched off for one second, on for one second, off for one second and then remains on.

3. Turn the switch back to the STOP setting, then to the MRES setting again within the next 3 seconds, and back to STOP.

Result: The STOP LED flashes for at least 3 seconds at 2 Hz (memory being reset) and then remains lit.

Running a memory reset upon request

Case B: The CPU requests memory reset, indicated by the flashing STOP LED at 0.5 Hz.

The system requests a CPU memory reset, for example, after a memory card was removed or inserted.

1. Set the mode selector switch to MRES and then back to STOP.

Result: The STOP LED flashes for at least 3 seconds at 2 Hz (memory being reset) and then remains lit.

For detailed information on CPU memory reset refer to the manual *S7-400 Automation System, Hardware and Installation*.

What happens in the CPU during a memory reset

When you run a memory reset, the following process occurs on the CPU:

- The CPU deletes the entire user program from main memory and load memory (integrated RAM and, if applicable, RAM card).
- The CPU clears all counters, bit memory, and timers (except for the time of day).
- The CPU tests its hardware.
- The CPU initializes its hardware and system program parameters (internal default settings in the CPU). Some default settings selected by the user will be taken into account.
- If a flash card is inserted, the CPU copies the user program and the system parameters stored on the flash card into main memory after the memory reset.

Values retained after a memory reset

After the CPU has been reset, the following values remain:

- The content of the diagnostic buffer
The content can be read out with the programming device using STEP 7.
- Parameters of the MPI (MPI address and highest MPI address). Note the special features shown in the table below.
- The IP address of the CPU
- The subnet mask
- The static SNMP parameters
- The time of day
- The status and value of the operating hours counter

Special features MPI parameters and IP address

A special situation is presented for the MPI parameters and IP address when a CPU memory reset is performed. The following table shows which MPI parameters and IP address remain valid after a CPU memory reset.

Table 2- 10 MPI parameters and IP address following memory reset

Memory reset ..	MPI parameters and IP address ...
With inserted FLASH card	..., stored on the FLASH card are valid
Without plugged FLASH card	...are retained in the CPU and valid

See also

You can also reset a CPU completely to the factory state. You can find more detailed information on this in the section "Resetting the CPU to the factory state (Page 55).

2.4.3 Cold start / Warm restart / Hot restart

Cold start

- During a cold restart, all data (process image, bit memory, timers, counters and data blocks) is reset to the start values stored in the program (load memory), irrespective of whether they were configured as retentive or non-retentive.
- The associated startup OB is OB 102
- Program execution is restarted from the beginning (OB 102 or OB 1).

Reboot (warm restart)

- A reboot resets the process image and the non-retentive flags, timers, times and counters.
Retentive flags, times and counters retain their last valid value.
All data blocks assigned the "Non Retain" attribute are reset to the downloaded values. The other data blocks retain their last valid value.
- The associated startup OB is OB 100
- Program execution is restarted from the beginning (OB 100 or OB 1).
- If the power supply is interrupted, the warm restart function is only available in backup mode.

Hot restart

- When a hot restart is performed, all data and the process image retain their last valid value.
- Program execution is resumed from the breakpoint.
- The outputs do not change their status until the current cycle is completed.
- The associated startup OB is OB 101
- If the power supply is interrupted, the hot restart function is only available in backup mode.

Operating sequence for reboot (warm restart)

1. Set the mode selector to STOP.

Result: The STOP LED lights up.

2. Set the switch to RUN.

Operating sequence for hot restart

1. Select the "hot restart" startup type on the PG.

The button can only be selected if this type of restart is possible on the specific CPU.

Operating sequence for cold restart

A manual cold restart can only be triggered from the programming device.

2.5 Structure and Functions of the Memory Cards

Order numbers

The order numbers of the memory cards are listed in section Technical specifications of the memory cards (Page 300).

Design

The memory card is slightly larger than a credit card and is protected by a strong metal casing. It is inserted into one of the slot on the front of the CPU. The memory card casing is encoded so it can only be inserted one way round.

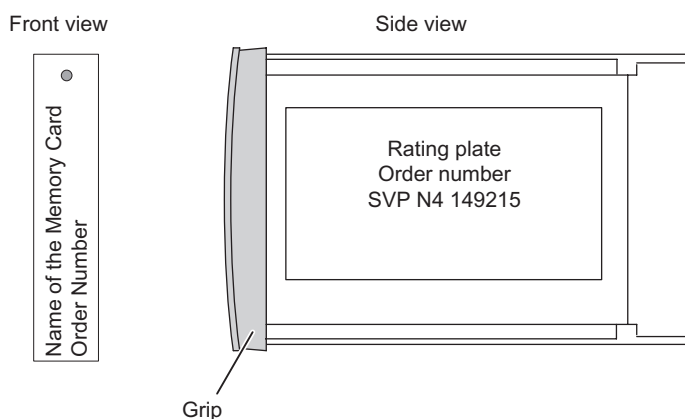

Figure 2-8 Design of the Memory Card

Function

The memory card and an integrated memory area on the CPU together form the load memory of the CPU. At runtime, the load memory contains the complete user program including comments, symbols and special additional information that allows the user program to be decompiled and all module parameters.

What is stored on the memory card

The following data can be stored on memory cards:

- User program, in other words, blocks (OBs, FBs, FCs, DBs) and system data
- Parameters which determine the behavior of the CPU
- Parameters which determine the behavior of the I/O modules
- The full set of project files on memory cards suitable for this

Serial number

In version 5 or later, all memory cards have a serial number. This serial number is listed in INDEX 8 of the SZL Parts List W#16#xy1C. The parts list can be read using SFC 51 "RDSYSST".

You can determine the following when you read the serial number into your user program:
The user program can only be started when a specific memory card is inserted in the CPU.
This protects against unauthorized copying of the user program, similar to a dongle.

See also

Overview of the memory concept of S7-400 CPUs (Page 185)

2.6 Use of the Memory Cards

Types of memory cards for S7-400

Two types of memory card are used in the S7-400:

- RAM cards
- Flash cards (FEPR0M cards)

Note

Non-Siemens memory cards cannot be used in the S7-400.

What type of memory card should be used?

Whether you use a RAM card or a flash card depends on how you intend to use the memory card.

Table 2- 11 Types of Memory Card

If you ...	Then ...
Want to store the data in RAM and edit your program in RUN,	Use a RAM card
Want to store your user program permanently on the memory card, even with power removed (without backup or outside the CPU),	Use a Flash card

RAM card

To use a RAM card and load the user program, you must insert it into the CPU slot. The user program is loaded with the help of the programming device (PG).

You can load the entire user program or individual elements such as FBs, FCs, OBs, DBs, or SDBs to the load memory when the CPU is in STOP or RUN mode.

All data on the RAM card is lost when you remove it from the CPU. The RAM card does not have a built-in backup battery.

If the power supply is equipped with an operational backup battery, or the CPU is supplied with an external backup voltage at the "EXT. BATT." input, the RAM card contents are retained when power is switched off, provided the RAM card remains inserted in the CPU and the CPU remains inserted in the rack.

FLASH card

There are two ways to download the user program if you are using a FLASH card:

Option 1:

1. Set the CPU mode to STOP with the mode selector switch.
2. Insert the FLASH card into the CPU.
3. Perform a memory reset.
4. Download the user program with the STEP 7 command "PLC -> Download User Program to Memory Card".

Option 2:

1. Download the user program to the FLASH card when the programming device / programming adapter is offline.
2. Insert the FLASH card into the CPU.

You can only reload the full user program using the FLASH card. You can download smaller program sections to the integrated load memory on the CPU using the programming device. For significant program changes, you must always download the complete user program to the FLASH card.

The FLASH card does not require a backup voltage, that is, the information stored on it is retained even when you remove the Flash card from the CPU or if you operate your S7-400 system without a buffering function (without backup battery in the power supply module or "EXT. BATT." socket of the CPU).

Automatic warm restart or cold restart without backup

If you operate your CPU without a backup battery, after startup or when voltage returns following POWER OFF, the CPU automatically undergoes a general reset and then a warm restart or cold restart, depending on the configuration. The user program must be available on the FLASH card and no battery monitoring can be set with the Batt.Indic switch on the power supply module.

What should be the capacity of the memory card?

The capacity of the required memory card is based on the size of the user program and amount of system data.

To optimize utilization of work memory (code and data) on your CPU, you should expand the load memory of the CPU with a memory card which has at least the same capacity as the work memory.

Changing the memory card

To change the memory card:

1. Set the CPU to STOP.
2. Remove the memory card.

Note

If you remove the memory card, STOP LED flashes at 3-second intervals to indicate that the CPU requires a memory reset. This sequence cannot be influenced by error OBs.

3. Insert the "new" memory card in the CPU.
4. Reset the CPU memory.

2.7 Multipoint Interface (MPI)

Availability

Every S7-400 CPU features an MPI interface.

Connectable devices

The following nodes can be connected to the MPI, for example:

- Programming devices (PG/PC)
- Control and monitoring devices (OPs and TDs)
- Additional SIMATIC S7 PLCs

Certain devices use the 24 VDC power supply of the interface. This voltage provided at the MPI interface is connected to reference potential

PG/OP ->CPU Communication

A CPU is capable of maintaining several simultaneous online connections for PG/OP communication. Only one of those connections is reserved as default connection for a programming device, and a second for the OP/ control and monitoring device.

For CPU-specific information on the number of connection resources or connectable OPs, refer to the technical specifications.

Time synchronization via MPI

The time can be synchronized via the MPI interface of the CPU. The CPU can be the time master or slave.

Reference

You can find information about planning time synchronization in the Process Control System PCS7; Safety Concept (<http://support.automation.siemens.com/WW/view/en/28580051>) manual.

CPU to CPU communication

There are three modes of CPU to CPU communication:

- Data exchanger by means of S7 basic communication
- Data exchange by means of S7 communication
- Data exchange by means of global data communication

For additional information, refer to the Programming with STEP 7 (<http://support.automation.siemens.com/WW/view/en/18652056>) manual.

Connectors

Always use bus connectors with angled cable outlet for PROFIBUS DP, or PG cables for connecting devices to the MPI (see the S7-400 Automation System, Hardware and Installation (<http://support.automation.siemens.com/WW/view/en/1117849>) manual).

MPI as PROFIBUS DP interface

You can also configure the MPI for operation as PROFIBUS DP interface. You can edit the MPI parameters accordingly in HW Config of STEP 7. This configuration allows you to set up a DP segment consisting of up to 32 slaves.

2.8 PROFIBUS DP Interface

Availability

The CPUs 41x-2, 41x-3 and 417-4 feature an integrated PROFIBUS DP interface. PROFIBUS DP interfaces are available as plug-in modules for the CPUs 41x-3, 417-4 and for CPUs with the suffix "PN/DP".

To be able to use those interfaces, you must first configure them HW Config and then download the configuration to the CPU.

Connectable devices

The PROFIBUS DP interface can be used to set up a PROFIBUS master system, or to connect PROFIBUS I/O devices.

You can connect any compliant DP slave to the PROFIBUS DP interface.

The CPU is then operated either as DP master or DP slave that is interconnected via PROFIBUS DP field bus with the passive slave stations or other DP masters.

Certain devices use the 24 VDC power supply of the interface. This voltage provided at the MPI interface is connected to reference potential

Connectors

Always use the bus connector for PROFIBUS DP, or PROFIBUS cables, to connect devices to the PROFIBUS DP interface (see the S7-400 Automation System, Hardware and Installation (<http://support.automation.siemens.com/WW/view/en/1117849>) manual).

Time synchronization via PROFIBUS

As the time master, the CPU broadcasts synchronization message frames on the PROFIBUS to synchronize additional stations.

If operated as time slave, the CPU receives synchronization frames from other time masters. One of the following devices can be the time master:

- A CPU 41x with internal PROFIBUS interface
- A CPU 41x with external PROFIBUS interface, e.g. CP 443-5
- A PC with CP 5613 or CP 5614

Reference

You can find information about planning time synchronization in the Process Control System PCS 7; Safety Concept (<http://support.automation.siemens.com/WW/view/en/28580051>) manual.

2.9 PROFINET interface

Availability

CPUs with "PN/DP" suffix feature an ETHERNET interface with PROFINET functionality.

Assigning an IP address

You have the following two options of assigning an IP address to the Ethernet interface:

1. Using the "PLC -> Edit Ethernet Node" command in SIMATIC Manager.
2. By editing the CPU properties in HW Config. Download the modified configuration to the CPU.

Devices which can be connected via PROFINET (PN)

- Programming device/PC with Ethernet adapter and TCP protocol
- Active network components, e.g. Scalance X200
- S7-300 / S7-400 with Ethernet CP, e.g. CPU 416-2 with CP 443-1
- PROFINET IO devices, e.g. IM 151-3 PN in an ET 200S
- PROFINET CBA components

Connectors

Always use RJ45 connectors to hook up devices to the PROFINET interface.

Time synchronization via PROFINET

The time is synchronized based on the NTP method. The CPU is an NTP client in this case.

Reference

- For additional information on PROFINET, refer to PROFINET System Description (<http://support.automation.siemens.com/WW/view/en/19292127>).
- For more information on Ethernet networks, network configuration and network components, refer to the SIMATIC NET: Twisted-pair and fiber-optic networks (<http://support.automation.siemens.com/WW/view/en/8763736>) manual.
- Component Based Automation, Commissioning SIMATIC iMap Systems - Tutorial (<http://support.automation.siemens.com/WW/view/en/18403908>) .
- Additional information on PROFINET (<http://www.profibus.com/pn/>).

2.10 Overview of the parameters for the S7-400 CPUs

Default values

All parameters are set to factory default values. Those defaults are suitable for a wide range of standard applications and enable the direct operation of an S7-400 system without users having to make any further settings.

You can define the CPU-specific default values using the "HW Config" tool in STEP 7.

Parameter fields

The behavior and properties of the CPU are declared in the parameters that are stored in system data blocks. The CPUs have a defined default setting. You can modify this default setting by editing the parameters in HW Config.

The list below provides an overview of the parameterizable system properties of the CPUs.

- General properties, e.g. the CPU name
- Startup, e.g. enabling hot restarts
- Synchronous cycle interrupts
- Cycle/clock memories (e.g. scan cycle monitoring time)
- Retentivity, i.e., the number of bit memories, timers and counters that are retained during restart
- Memory, e.g. local data

Note: After you reconfigured RAM allocation parameters, this RAM is reorganized when system data is downloaded to the CPU. As a consequence, the data blocks generated by means of SFC are deleted and the remaining data blocks are initialized with values from load memory.

The RAM resources which can be utilized for logic or data blocks are changed when system data is downloaded if you change the following parameters:

- Size of the process image, byte-oriented; in the "Cycle/Clock Memory" tab
- Communication resources in the "Memory" tab
- Size of the diagnostics buffer in the "Diagnostics/Clock" tab
- Number of local data for all priority classes in the "Memory" tab
- Assignment of interrupts, process interrupts, time-delay interrupts and asynchronous error interrupts to the priority classes
- Time interrupts, e.g., interval duration and priority
- Watchdog interrupts, e.g. priority, interval duration
- Diagnostics/clock, e.g. time synchronization
- Security class

- Web (for CPU 41x PN/DP)
- Setting the CPU number (for multicomputing)

Note

16 memory bytes and 8 counters are set by default in non-volatile memory, i.e., they are not deleted at a restart of the CPU.

Parameterization tool

You can set up CPU parameters using the "Hardware Configuration" dialog in STEP 7.

Note

After you made changes to the existing settings of the following parameters, the operating system performs an initialization similar to the cold restart.

- Size of the process image of inputs
- Size of the process image of outputs
- Size of local data
- Number of diagnostics buffer entries
- Communication resources

This involves the following initializations: procedures

- Data blocks are initialized with the load values.
 - Bit memories, timers, counters, inputs and outputs are deleted, regardless of their retentivity setting (0).
 - DBs generated by means of SFC are deleted
 - Permanently configured, base communication connections are shutdown
 - All run levels are initialized.
-

Special functions of a CPU 41x

3.1 Multicomputing

3.1.1 Fundamentals

Multicomputing Mode

Multicomputing mode is the simultaneous operation of several (up to 4) CPUs in a central rack of the S7-400.

The CPUs involved automatically change their modes synchronized with each other; the CPUs start up together and change to STOP together. The user program on each CPU runs independently of the user programs on the other CPUs. This allows control tasks to be performed simultaneously.

Racks suitable for Multicomputing

The following racks are suitable for multicomputing:

- UR1 and UR2
- UR2-H, multicomputing with several CPUs is possible only if the CPUs are in the same subdevice.
- CR3, since the CR3 has only 4 slots, multicomputing is possible only with two CPUs.

Difference Compared with Operation in a Segmented Rack

In the CR2 segmented rack (physically segmented, cannot be set using parameters), only one CPU per segment is permitted. This is, however, not multicomputing. The CPUs in the segmented rack each form an independent subsystem and behave like individual processors. There is no common logical address space.

Multicomputing is not possible in the segmented rack (see also *S7-400 Automation System, Hardware and Installation*).

Uses

There are benefits in using multicomputing in the following situations:

- When your user program is too large for one CPU and memory starts running short, distribute your program over several CPUs.
- When a particular part of your plant needs to be processed quickly, separate the relevant program section from the overall program and run this part on a separate "fast" CPU.
- When your plant consists of several parts with a clear demarcation between them so that they can be controlled relatively independently, process plant part 1 on CPU1, plant part 2 on CPU2 etc.

Example

The following figure shows an automation system operating in multicomputing mode. Each CPU can access the modules assigned to it (FM, CP, SM).

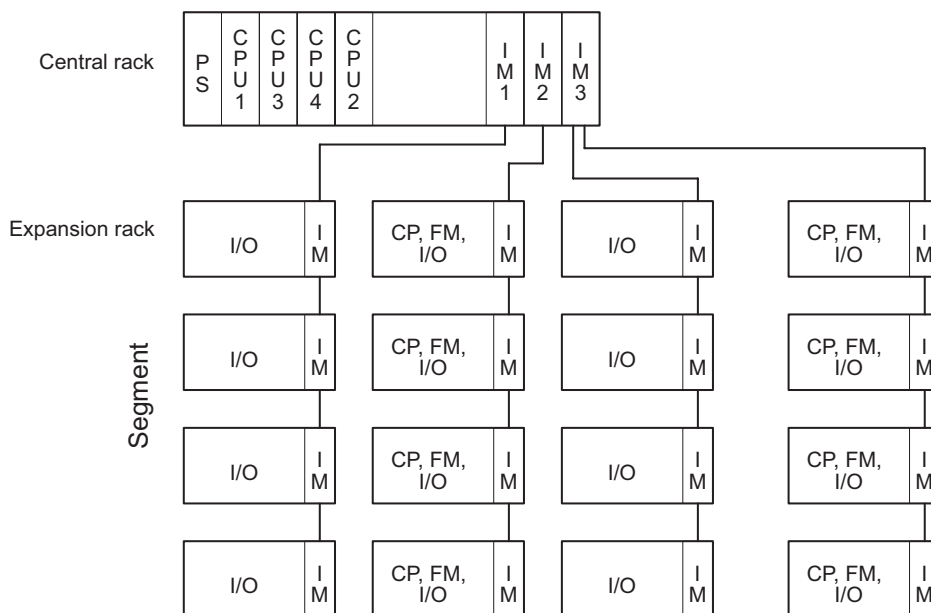

Figure 3-1 Example of multicomputing

3.1.2 Special Features at Multicomputing

Slot Rules

In multicomputing mode, up to four CPUs can be inserted in one central controller (CC) in any order.

Accessibility of the CPUs.

All CPUs can be accessed from the programming device if configured accordingly via the MPI interface, PROFIBUS DP interface or PROFINET PN interface **of one** CPU.

Downloading the Configuration in Multicomputing Mode

If you want to use multicomputing, in very rare cases with very large configurations, you may find that the CPUs do not start up after the configuration has been downloaded to the PLC ("PLC > Download to Module" menu command in HW Config).

Remedy: Perform a memory reset for all the CPUs. Then download your system data (and all blocks) to each CPU in succession in Simatic Manager. Start with the CPU with the highest CPU number, always followed by the CPU with the next lowest number. Then switch the CPUs to RUN in the same order.

Behavior during Startup and Operation

During startup, the CPUs involved in multicomputing automatically check whether they can synchronize themselves. Synchronization is possible only in the following situations:

- When all the configured and only the configured CPUs are inserted and ready to operate.
- If correct configuration data was created with STEP 7 and was downloaded to all plugged-in CPUs.

If one of these conditions is not fulfilled, the event is entered in the diagnostic buffer with ID 0x49A4. You will find explanations of the event IDs in the reference help on standard and system functions.

When STOP mode is left, the types of startup COLD RESTART/WARM RESTART/HOT RESTART are compared. If the types of startup are different, the CPUs do **not** change to RUN.

Address and Interrupt Assignment

In multicomputing, the individual CPUs can access the modules assigned to them during configuration with STEP 7. The address area of a module is always assigned "exclusively" to one CPU.

In particular, this means that every module with interrupt capability is assigned to a CPU. Interrupts triggered by such a module cannot be received by the other CPUs.

Interrupt Processing

The following applies to interrupt processing:

- Hardware interrupts and diagnostic interrupts are sent to only one CPU.
- If a module fails or is removed/inserted, the interrupt is processed by the CPU to which the module was assigned during parameter assignment with STEP 7.
Exception: A remove/insert interrupt triggered by a CP reaches all CPUs even if the CP was assigned to one CPU during configuration with STEP 7.
- If a rack fails, OB86 is called on every CPU; in other words, it is also called on the CPUs to which no module in the failed rack was assigned.

For more detailed information on OB86, refer to the reference help on organization blocks.

Number of I/Os

The number of I/Os of an automation system in multicomputing mode corresponds to the number of I/Os of the CPU with the most resources. The configuration limits for the specific CPU or specific DP master must not be exceeded in the individual CPUs.

3.1.3 Multicomputing interrupt

Principle

Using the multicomputing interrupt (OB60), you can synchronize the CPUs involved in multicomputing to an event. In contrast to the hardware interrupts that are triggered by signal modules, the multicomputing interrupt can only be output by CPUs. The multicomputing interrupt is triggered by calling SFC35 "MP_ALM".

For more detailed information, refer to the *System Software for S7-300/400, System and Standard Functions*.

3.1.4 Configuring and programming multicomputing mode

Reference

For information on the procedure for configuring and programming CPUs and modules, refer to the *Configuring Hardware and Connections with STEP 7*.

3.2 System modifications during operation

3.2.1 Basics

Overview

The option of making system changes using CiR (Configuration in RUN) makes it possible to implement certain configuration changes in RUN. Processing of the process is held for a short period of time. The default upper limit of this period of 1 s can be changed by the user. During this time, process inputs retain their last value (refer to the "Modifying the System during Operation via CiR" (<http://support.automation.siemens.com/WW/view/en/14044916>) manual).

System modifications at runtime using CiR can be made in systems sections with distributed I/O. Such changes are only possible with the configuration shown in the figure below. To maintain a clear overview, the view was restricted to a single DP master system and a single PA master system. These restrictions do not exist in reality.

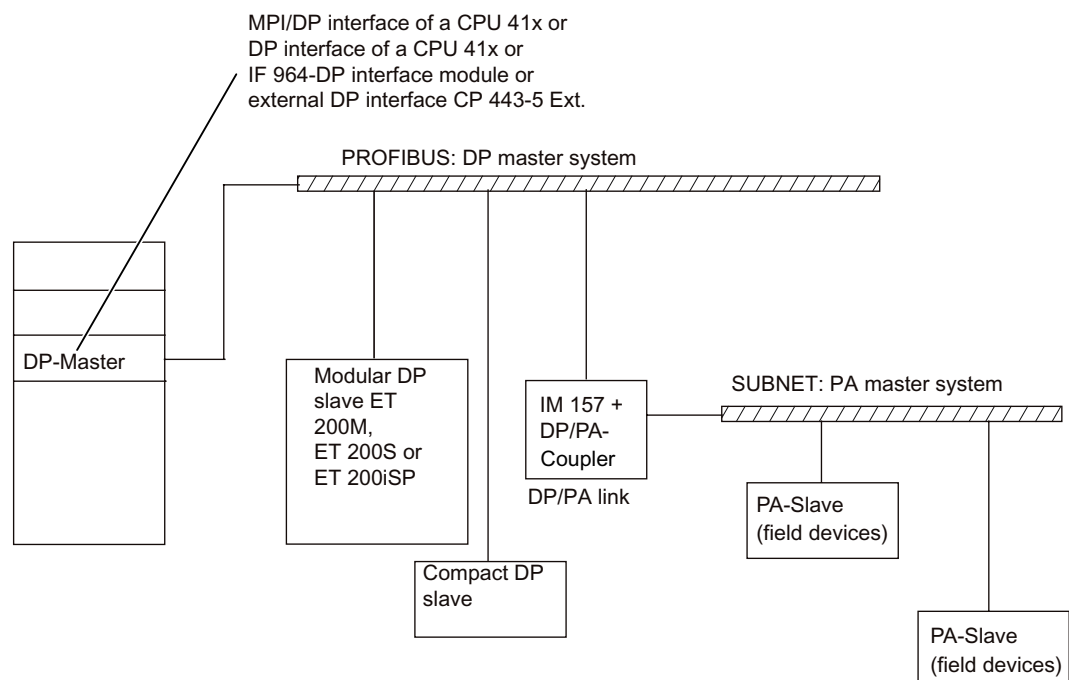

Figure 3-2 Overview: System structure for system modifications in run

3.2.2 Hardware requirements

Hardware requirements for system modifications during operation

To be able to make system modifications during operation, the following hardware requirements must be met during commissioning:

- If you want to make system changes to a DP master system with an external DP master (CP 443-5 extended) during operation, this must have at least firmware version V5.0.
- If you want to add modules to an ET 200M: Use of the IM 153-2 as of MLFB 6ES7153-2BA00-0XB0 or the IM 153-2FO as of MLFB 6ES7 153-2BB00-0XB0. You must also set up the ET 200M with active bus elements and adequate free space for the planned expansion. The ET 200M must not be linked as a DPV0 slave (using a GSD file).
- If you want to add entire stations: Reserve the necessary bus connectors, repeaters etc.
- If you want to add PA slaves (field devices): Use of the IM 157 as of MLFB 6ES7157-0AA82-0XA00 in the appropriate DP/PA-Link.
- Use of the CR2 rack is not permitted.
- The use of one or more of the modules listed below within a station in which you want to make system changes during operation with CiR is not permitted. CP 444, IM 467.
- No multicomputing
- No isochronous operation in the same DP master system
- System changes cannot be made to PROFINET IO systems.

Note

You can mix components that are compliant with system changes during operation and those that are not (with the exception of the modules excluded above). You can, however, only make modifications to CiR-compliant components.

3.2.3 Software requirements

Software Requirements for System Modifications during Operation

To be able to make configuration changes in RUN, the user program must meet the following requirement: It must be written so that, for example, station failures, module faults or timeouts do not cause the CPU to change to STOP.

The following OBs must be available on your CPU:

- Hardware interrupt OBs (OB 40 to OB 47)
- Time jump OB (OB80)
- Diagnostic interrupt OB (OB82)
- Remove/insert OB (OB83)
- CPU hardware fault OB (OB84)
- Program execution error OB (OB85)
- Rack failure OB (OB86)
- I/O access error OB (OB122)

3.2.4 Permitted system modifications

Overview

During operation, you can make the following system modifications:

- Add modules to the ET 200M modular DP slave provided that you have not linked it as a DPV0 slave (using a GSD file).
- Change the parameter assignment of ET 200M modules, for example, setting different limits or using previously unused channels.
- Use previously unused channels in a module or submodule in the ET 200M, ET 200S, ET 200iS modular slaves.
- Add DP slaves to an existing DP master system.
- Add PA slaves (field devices) to an existing PA master system.
- Add DP/PA couplers downstream from an IM157.
- Add PA-Links (including PA master systems) to an existing DP master system.
- Assign added modules to a process image partition.

3.2 System modifications during operation

- Reassign parameters for existing ET 200M stations (standard modules and fail-safe signal modules in standard mode).
- Reversing changes: Added modules, submodules, DP slaves and PA slaves (field devices) can be removed again.

Note

If you want to add or remove slaves or modules or modify the existing process image partition assignment, this is possible in a maximum of four DP master systems.

All other modifications not specifically permitted above are not permitted during operation and are not further discussed here.

3.3 Resetting the CPU to the factory state

CPU factory settings

A general memory reset is performed when you reset the CPU to its factory settings and the properties of the CPU are set to the following values:

Table 3- 1 CPU properties in the factory settings

Properties	Value
MPI address	2
MPI transmission rate	187.5 Kbps
Contents of the diagnostic buffer	Empty
IP parameters	None
IP parameters	Default values
Operating hours counters	0
Date and time	01.01.94, 00:00:00

Procedure

Proceed as follows to reset a CPU to its factory settings:

1. Switch off the mains voltage.
2. If a memory card is inserted in the CPU, always remove the memory card.
3. Hold the toggle switch in the MRES setting and switch the mains voltage on again.
4. Wait until LED pattern 1 from the following overview is displayed.
5. Release the toggle switch, set it back to MRES within 3 seconds and hold it in this position.
After approx. 4 seconds all the LEDs light up.
6. Wait until LED pattern 2 from the following overview is displayed.
This LED pattern lights up for approximately 5 seconds. During this period you can abort the resetting procedure by releasing the toggle switch.
7. Wait until LED pattern 3 from the following overview is displayed, and release the toggle switch again.

The CPU is now reset to its factory settings. It starts without buffering and goes to STOP mode. The event "Reset to factory setting" is entered in the diagnostic buffer.

LED patterns during CPU reset

While you are resetting the CPU to its factory settings, the LEDs light up consecutively in the following LED patterns:

Table 3-2 LED patterns

LED	LED pattern 1	LED pattern 2	LED pattern 3
INTF	B 0.5 Hz	B 0.5 Hz	H
EXTF	D	D	D
BUSxF	D	D	D
FORCE	B 0.5 Hz	D	D
MAINT	D	D	D
IFMxF	D	D	D
RUN	B 0.5 Hz	D	D
STOP	B 0.5 Hz	D	D

D = LED is dark; L = LED lights up; F = LED flashes at the specified frequency

3.4 Updating the firmware without a memory card

Basic procedure

To update the firmware of a CPU, you will receive several files (*.UPD) containing the current firmware. Download these files to the CPU. You do not need a memory card to perform an online update. However, it is still possible to update the firmware using a memory card.

Requirement

The CPU whose firmware you want to update must be accessible online, for example, via PROFIBUS, MPI or Industrial Ethernet. The files containing the current firmware version must be available in the PG/PC file system. A folder may contain only the files of one firmware version.

Note

For CPUs with the suffix "PN/DP", you can update the firmware at the PROFINET interface via Industrial Ethernet. The update via Industrial Ethernet is much faster than via MPI or DP (depending on the configured baud rate).

You can update the firmware of the other CPUs via Industrial Ethernet if the CPU is connected to the Industrial Ethernet via a CP.

Procedure

Proceed as follows to update the firmware of a CPU:

1. Open the station containing the CPU you want to update in HW Config.
2. Select the CPU.
3. Select the "PLC > Update Firmware" menu command.
4. In the "Update Firmware" dialog, select the path to the firmware update files (CPU_HD.UPD) using the "Browse" button.

After you have selected a file, the information in the bottom boxes of the "Update Firmware" dialog box indicate the modules for which the file is suitable and from which firmware version.

5. Click on "Run."

STEP 7 verifies that the selected file can be interpreted by the CPU and then downloads the file to the CPU. If this requires changing the operating state of the CPU, you will be asked to do this in the relevant dialog boxes.

Values retained after a firmware update

After the CPU has been reset, the following values remain:

- Parameters of the MPI (MPI address and highest MPI address).
- The IP address of the CPU
- The subnet mask
- The static SNMP parameters

3.5 Reading out service data

Use Case

In a service situation in which you need to call Customer Support, it is possible that Customer Support will need special information about the status of a CPU in your system for diagnostic purposes. This information is stored in the diagnostic buffer and in the actual service data.

You can read this information with the menu command "PLC > Save Service Data" and save it in two files. You can then send this to Customer Support.

Note the following:

- Save the service data directly after a CPU changes to STOP mode if possible.

The path and the file name under which the service data is stored are specified when the information is read.

Procedure

1. Select the CPU with the "SIMATIC Manager > Accessible Nodes" menu command.
2. Select the "PLC > Save Service Data" menu command.
A dialog box opens in which you specify the storage location and name of the two files.
3. Save the file.
4. If requested, send the files to Customer Support.

Communication

4.1 interfaces

4.1.1 Multi-Point Interface (MPI)

Availability

The MPI/DP interface of an S7-400 CPU in the factory state is set as an MPI interface with an address of 2.

Properties

The MPI represents the CPU interface for PG/OP connections or for communication on an MPI subnet.

The preset transmission rate for all CPUs is 187.5 Kbps. The maximum transmission rate is 12 Mbps.

The CPU automatically broadcasts its configured bus parameters via the MPI interface (the baud rate, for example). A programming device, for example, can thus receive the correct parameters and automatically connect to a MPI subnet. Nodes with different bus parameters to those set on the CPU cannot be operated on the MPI subnet.

Note

In runtime, you may only connect programming devices to an MPI subnet. Other stations, such as OP or TP, should not be connected to the MPI subnet in runtime. Otherwise, transferred data might be corrupted due to interference pulses or global data packages may be lost.

Time synchronization

Time synchronization is possible by using the MPI interface of the CPU. The CPU can be master or slave.

MPI Interface as a PROFIBUS DP Interface

You can also configure the MPI interface for operation as a PROFIBUS DP interface. To do so, you can reconfigure the MPI interface under STEP 7 in HW Config. You can use this to set up a DP line consisting of up to 32 slaves.

Devices capable of MPI communication

- PG/PC
- OP/TP
- S7-300 / S7-400 with MPI interface
- S7-200 only with 19.2 Kbps and 187.5 Kbps

4.1.2 PROFIBUS DP

Availability

The CPUs 41x-2, 41x-3 and 417-4 feature an integrated PROFIBUS DP interface.

PROFIBUS DP interfaces are available as plug-in modules for the CPUs 41x-3, 417-4 and for CPUs with the suffix "PN/DP". Those interfaces must be prepared for operation by configuring them in HW Config. You can use the plugged DP modules after having downloaded the configuration.

The configuration of an MPI/DP interface delivered with a CPU is set up by default to MPI mode. To operate the MPI/DP interface in DP mode, you must reconfigure it accordingly in STEP 7.

Properties

The PROFIBUS DP interface is primarily used to connect distributed I/O. You can configure the PROFIBUS DP interface for operation in master or slave mode. The interface supports transmission rates up to 12 Mbps.

The CPU broadcasts its bus parameters, such as the transmission rate, via the PROFIBUS DP interface if master mode is set. A programming device, for example, can receive the correct parameters and automatically connect itself to a PROFIBUS subnet.

Time synchronization via PROFIBUS DP

A CPU operating as time master broadcasts synchronization message frames on PROFIBUS to synchronize additional stations.

If operated as time slave, the CPU receives synchronization frames from other time masters. One of the following devices can be the time master:

- A CPU 41x with internal PROFIBUS interface
- A CPU 41x with external PROFIBUS interface, e.g. CP 443-5
- A PC with CP 5613 or CP 5614

Devices which can be connected via PROFIBUS DP

The PROFIBUS DP interface can be used to set up a PROFIBUS master system, or to connect PROFIBUS I/O devices.

The following devices can be connected to the PROFIBUS DP interface:

- PG/PC
- OP/TP
- PROFIBUS DP slaves
- PROFIBUS DP master

The CPU is then operated either as DP master or DP slave that is interconnected via PROFIBUS DP field bus with the passive slave stations or other DP masters.

Certain devices use the 24 VDC power supply of the interface. This voltage provided at the MPI interface is connected to reference potential

Reference

Additional information on PROFIBUS (<http://www.profibus.com/pb/>).

4.1.3 PROFINET

Availability

CPUs with "PN/DP" suffix feature an ETHERNET interface with PROFINET functionality.

Assigning an IP address

You have the following two options of assigning an IP address to the Ethernet interface:

1. Using the "PLC -> Edit Ethernet Node" command in SIMATIC Manager.
2. By editing the CPU properties in HW Config. Download the modified configuration to the CPU.

Devices which can be connected via PROFINET (PN)

- Programming device/PC with Ethernet adapter and TCP protocol
- Active network components, e.g. Scalance X200
- S7-300 / S7-400 with Ethernet CP, e.g. CPU 416-2 with CP 443-1
- PROFINET IO devices, e.g. IM 151-3 PN in an ET 200S
- PROFINET CBA components

Connectors

Always use RJ45 connectors to hook up devices to the PROFINET interface.

Properties of the PROFINET interface

Protocols and communication functions
PROFINET IO PROFINET CBA
In accordance with IEC61784-2 , Conformance Class A and BC
Open block communication over <ul style="list-style-type: none"> • TCP • UDP • ISO on TCP
S7 communication
Programming device functions
SNMP
LLDP
Time synchronization using the NTP method as a client

Connection	
Version	2 x RJ45
	Switch with 2 ports
Media	Twisted pair Cat5
Transmission rate	10/100 Mbps
	Autosensing
	Autocrossing Autonegotiation

Note

Networking PROFINET components

The PROFINET interfaces of our devices are set to "automatic setting" (autonegotiation) by default. Verify that all devices connected to the PROFINET interface of the CPU are also set to the "Autonegotiation" mode. This is the default setting of standard PROFINET / Ethernet components.

If connecting a device to the on-board PROFINET interface of the CPU that does not support the "automatic setting" (Autonegotiation) operating mode, or selecting a setting other than the "automatic setting" (Autonegotiation), note the following:

- PROFINET IO and PROFINET CBA require operation at 100 Mbps in full-duplex mode, i.e. if the on-board PROFINET interface of the CPU for PROFINET IO/CBA communication and Ethernet communication is used at the same time, the PROFINET interface can only be operated at 100 Mbps in full-duplex mode.
- Operation at 100 Mbps full-duplex or 10 Mbps full-duplex is possible if the on-board PROFINET interface(s) of the CPU is used only for Ethernet communication. Half-duplex mode is not allowed in any situation.

Background: If a switch that is permanently set to 10 Mbps half-duplex is connected to the interface of the CPU, the "Autonegotiation" setting forces the CPU to adapt itself to the settings of the partner device, i.e. the communication operates de facto at "10 Mbps half-duplex". However, this operating mode is not allowed because PROFINET IO and PROFINET CBA require operation at 100 Mbps full-duplex.

Reference

- For additional information on PROFINET, refer to PROFINET System Description (<http://support.automation.siemens.com/WW/view/en/19292127>)
- For detailed information about Ethernet networks, network configuration and network components refer to the SIMATIC NET manual: Twisted-pair and fiber-optic networks (<http://support.automation.siemens.com/WW/view/en/8763736>) manual.
- Component Based Automation, Commissioning SIMATIC iMap Systems - Tutorial (<http://support.automation.siemens.com/WW/view/en/18403908>) .
- Additional information on PROFINET (<http://www.profinet.com/pn/>).

4.2 Communication services

4.2.1 Overview of communication services

Overview

Table 4- 1 Communication services of the CPUs

Communication service	Functionality	Allocation of S7 connection resources	via MPI	via DP	via PN/IE
PG communication	Commissioning, testing, diagnostics	Yes	Yes	Yes	Yes
OP communication	Operator control and monitoring	Yes	Yes	Yes	Yes
S7 basic communication	Data exchange	Yes	Yes	Yes	No
S7 communication	Data exchange via configured connections	Yes	Yes	Yes	Yes
Global data communication	Cyclic data exchange, e.g. bit memories	No	Yes	No	No
Routing of PG functions	e.g. testing, diagnostics beyond network boundaries	Yes	Yes	Yes	Yes
PROFIBUS DP	Data exchange between master and slave	No	No	Yes	No
PROFINET CBA	Data exchange by means of component-based communication	No	No	No	Yes
PROFINET IO	Data exchange between I/O controllers and I/O devices	No	No	No	Yes
Web server	Diagnostics	No	No	No	Yes
SNMP (Simple Network Management Protocol)	Standard protocol for network diagnostics and parameterization	No	No	No	Yes
Open communication over TCP/IP	Data exchange over Industrial Ethernet with TCP/IP protocol (with loadable FBs)	Yes	No	No	Yes
Open communication over ISO on TCP	Data exchange over Industrial Ethernet with ISO on TCP protocol (with loadable FBs)	Yes	No	No	Yes
Open communication over UDP	Data exchange over Industrial Ethernet with UDP protocol (with loadable FBs)	Yes	No	No	Yes
Data set routing	for example, configuration and diagnostics of field devices on PROFIBUS DP via C2 channel	Yes	Yes	Yes	Yes

Connection resources In the S7-400

S7-400 components are equipped with a module-specific number of connection resources.

Availability of connection resources

Table 4- 2 Availability of connection resources

CPU	Total number of connection resources	Of those are reserved for	
		PG communication	OP communication
412 414	32	1	1
416 417	64	1	1

Free S7 connections can be used for any of the above communication services.

Note

Communication service via the PROFIBUS DP interface

A fixed default timeout of 40 s is specified for communication services using S7 connection resources. Reliable operation of those communication services at a low baud rate via PROFIBUS DP interface can be ensured in configurations with a Ttr (Target Rotation Time) < 20 s.

4.2.2 PG communication

Properties

Programming device communication is used to exchange data between engineering stations (PG, PC, for example) and SIMATIC modules which are capable of communication. This service is available for MPI, PROFIBUS and Industrial Ethernet subnets. Routing between subnets is also supported.

You can use the programming device communication for the following actions:

- Loading programs and configuration data
- Performing tests
- Evaluating diagnostic information

These functions are integrated in the operating system of SIMATIC S7 modules.

A CPU can maintain several simultaneous online connections to one or multiple programming devices.

4.2.3 OP communication

Properties

OP communication is used to exchange data between HMI stations, such as WinCC, OP, TP and SIMATIC modules which are capable of communication. This service is available for MPI, PROFIBUS and Industrial Ethernet subnets.

You can use the OP communication for operator control, monitoring and alarms. These functions are integrated in the operating system of SIMATIC S7 modules. A CPU can maintain several simultaneous connections to one or several OPs.

4.2.4 S7 basic communication

Properties

S7-based communication is used to exchange data between S7 CPUs and the communication-enabled SIMATIC modules within an S7 station (acknowledged data communication). The service is available via the MPI subnet or within the station to function modules (FM).

You do not need to configure connections for basic S7 communication. The integrated communication functions are called via SFCs in the user program.

SFCs for S7 basic communication

The following SFCs are integrated in the operating system of the S7-400 CPUs:

Table 4- 3 SFCs for S7 Basic Communication

Block	Block name	Brief description
SFCs for external communication		
SFC 65 SFC 66	X_SEND X_RCV	Transfers a data block to a communication partner.
SFC 67	X_GET	Reads a tag from a communication partner
SFC 68	X_PUT	Writes a tag to a communication partner
SFC 69	X_ABORT	Cancel an established connection without transferring data
SFCs for internal communication		
SFC 72	I_GET	Reads a tag from a communication partner
SFC 73	I_PUT	Writes a tag to a communication partner
SFC 74	I_ABORT	Cancel an established connection without transferring data

Reference

- Refer to the *operation list* to learn which SFCs are included in the operating system of a CPU.
- You can find detailed descriptions of the SFCs in the *STEP 7 Online Help* or *System and Standard Functions* reference manual.

4.2.5 S7 communication

Properties

A CPU can act as a server or client in S7 communication: A connection is configured permanently. The following connections are possible:

- One-sided configured connections (for PUT/GET only)
- Two-side configured connections (for USEND, URCV, BSEND, BRCV, PUT, GET)

You can use S7 communication via integral interfaces (MPI/DP, PROFIBUS-DP, PROFINET) and, if necessary, via additional communication processors (CP443-1 for Industrial Ethernet, CP443-5 for PROFIBUS). Read the Technical Specifications to see which interfaces are integrated into your CPU.

The S7-400 features integrated S7 communication services that allow the user program in the controller to initiate reading and writing of data. The S7 communication functions are called via SFBs in the user program. These functions are independent of the specific network, allowing you to program S7 communication over PROFINET, Industrial Ethernet, PROFIBUS, or MPI.

S7 communication services provide the following functions:

- During system configuration, you configure the connections used by the S7 communication. These connections remain configured until you download a new configuration.
- You can establish several connections to the same partner. The number of communication partners accessible at any time is restricted to the number of connection resources available.

NOTICE
Downloading connection configuration during operation
When you load a modified connection configuration during operation, connections which have been set up which are not affected by changes in the connection configuration may also be aborted.

S7 communication allows you to transfer a block of up to 64 KB per call to the SFB. An S7-400 transfers a maximum of 4 tags per block call.

SFBs for S7 Communication

The following SFBs are integrated in the operating system of the S7-400 CPUs:

Table 4- 4 SFBs for S7 Communication

Block	Block name	Brief description
SFB 8 SFB 9	USEND URCV	Send data to a remote partner SFB with the type "URCV" Receive asynchronous data from a remote partner SFB with the type "USEND"
SFB 12 SFB 13	BSEND BRCV	Send data to a remote partner SFB with the type "BRCV" Receive asynchronous data from a remote partner SFB with the type "BSEND" With this data transfer, a larger amount of data can be transported between the communication partners than is possible with all other communications SFBs for the configured S7 connections.
SFB 14	GET	Read data from a remote CPU
SFB 15	PUT	Write data to a remote CPU
SFB 16	PRINT	Send data via a CP 441 to a printer
SFB 19	START	Carry out a reboot (warm restart) or cold restart in a remote station
SFB 20	STOP	Set a remote station to STOP state
SFB 21	RESUME	Carry out a hot restart in a remote station
SFB 22	STATUS	Query the device status of a remote partner
SFB 23	USTATUS	Uncoordinated receiving of a remote device status

Integration into STEP 7

S7 communication offers communication functions through configured S7 connections. You use STEP 7 to configure the connections.

S7 connections with an S7-400 are established when the connection data is downloaded.

4.2.6 Global data communication

Properties

Global data communication is used for cyclic exchange of global data via MPI subnets (for example, I, Q, M) between SIMATIC S7 CPUs. The exchange of data is unacknowledged. One CPU broadcasts its data to all other CPUs on the MPI subnet.

The integrated communication functions are called via SFCs in the user program.

SFCs for Global Data Communication

The following SFCs are integrated in the operating system of the S7-400 CPUs:

Table 4- 5 SFCs for Global Data Communication

Block	Block name	Brief description
SFC 60	GD_SEND	Collects and sends data of a GD packet
SFC 61	GD_REC	Fetches data of an arrived GD message frame and enters it in the receive GD packet.

Reduction ratio

The reduction ratio specifies the number of cycles into which the GD communication is broken down. You set the reduction ratio when you configure global data communication in STEP 7. For example, if you set a reduction ratio of 7, global data communication is performed every 7th cycle. This reduces the load on the CPU.

Send and Receive Conditions

Meet the following conditions for communication via GD circuits:

- For the sender of a GD packet:
Reduction ratio_{sender} x cycle time_{sender} ≥ 60 ms
- For the receiver of a GD packet:
Reduction ratio_{receiver} x cycle time_{receiver}
< reduction ratio_{sender} x cycle time_{sender}

A GD packet may be lost if you do not adhere to these conditions. The reasons being:

- The performance of the "smallest" CPU in the GD circuit
- Transmission and reception of global data is performed asynchronously at the stations.

When setting in STEP 7: "Transmit after each CPU cycle", and the CPU has a scan cycle time < 60 ms, the operating system might overwrite a GD packet of the CPU before it is transmitted. The loss of global data is indicated in the status box of a GD circuit, if you set this function in your STEP 7 configuration.

4.2.7 S7 routing

Properties

You can access your S7 stations beyond subnet boundaries using the programming device / PC. You can use them for the following actions:

- Downloading user programs
- Downloading a hardware configurations
- Performing tests and diagnostics functions

Note

On a CPU used as intelligent slave the S7 routing function is only available if the DP interface is activated. In STEP 7, check the Test, Commissioning, Routing check box in the properties dialog of the DP interface. For more information, refer to the *Programming with STEP 7* manual, or directly to the *STEP 7 Online Help*

Requirements

- The network configuration does not exceed project limits.
- The modules have loaded the configuration data containing the latest "knowledge" of the entire network configuration of the project.

Reason: All modules connected to the network gateway must receive routing information which defines the paths to other subnets.

- In your network configuration, the PG/PC you want to use to set up a connection via gateway must be assigned to the network to which it is physically connected.
- The CPU must set to master mode, or
- if the CPU is configured as a slave, the "Programming, status/modify or other PG functions" check box must be activated in the properties of the DP interface for the DP slave in STEP 7.

S7 routing gateways: MPI to DP

Gateways between subnets are routed in a SIMATIC station that is equipped with interfaces to the respective subnets. The following figure shows CPU 1 (DP master) acting as router for subnets 1 and 2.

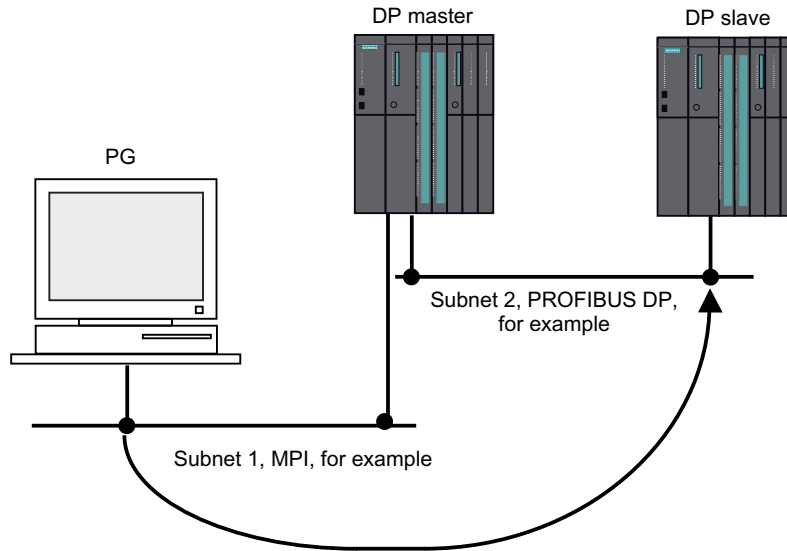

Figure 4-1 S7 routing

S7 routing gateways: MPI - DP - PROFINET

The following figure shows access from MPI to PROFINET via PROFIBUS. CPU 1, for example 416-3, is the router for subnet 1 and 2; CPU 2 is the router for subnet 2 and 3.

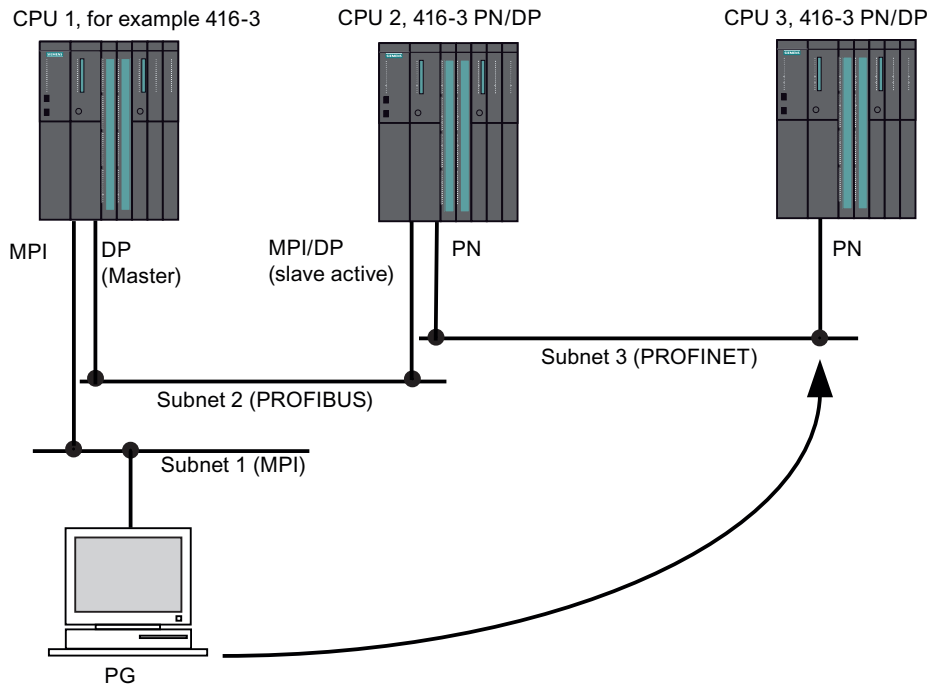

Figure 4-2 S7 routing gateways: MPI - DP - PROFINET

S7 routing: TeleService application example

The following figure shows an application example of the remote maintenance of an S7 station using a PG. The connection to other subnets is set up via modem.

The bottom of the figure shows how this can be configured in STEP 7.

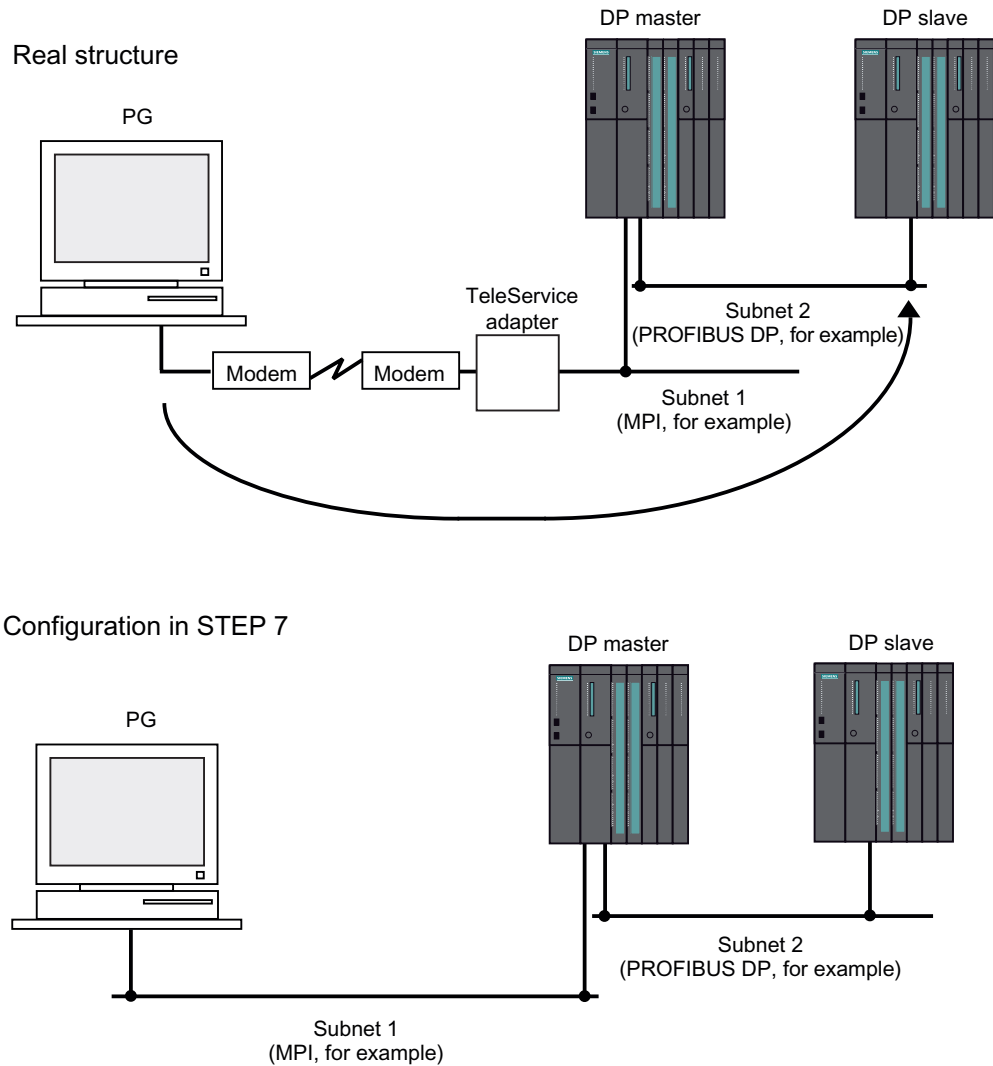

Figure 4-3 S7 routing: TeleService application example

Reference

- You can find additional information on configuring in STEP 7 in the Configuring Hardware and Connections with STEP 7 (<http://support.automation.siemens.com/WW/view/en/18652631>) manual
- More basic information is available in the Communication with SIMATIC (<http://support.automation.siemens.com/WW/view/en/25074283>) manual.
- For more information about the TeleService adapter, refer to the manual TS-Adapter (<http://support.automation.siemens.com/WW/view/en/20983182>)
- For additional information about SFCs, refer to the Instructions list. (<http://support.automation.siemens.com/WW/view/en/23904435>)
For more information, refer to the *STEP 7 Online Help*, or to the System and Standard Functions (<http://support.automation.siemens.com/WW/view/en/1214574>) manual.

4.2.8 Time synchronization

Introduction

The S7-400 has a powerful timer system. You can synchronize this timer system using a higher-level time generator, which will allow you to synchronize, complete, document and archive time-critical sequences.

Interfaces

Time synchronization is possible via every interface of the S7-400:

- **MPI interface**
You can configure the CPU as a time master or a time slave.
- **PROFIBUS DP Interface**
You can configure the CPU as a time master or a time slave.
- **PROFINET interface via Industrial Ethernet**
Time synchronization using the NTP method; the CPU is the client.
- **Via the S7-400 backplane bus**
You can configure the CPU as a time master or a time slave.

CPU as a time master

If you configure the CPU as a time master, you must specify a synchronization interval. You can select any interval between 1 second and 24 hours.

If the CPU time master is on the S7-400 backplane bus, you should select a synchronization interval of 10 seconds.

The time master sends its first message frame once the time has been set for the first time (via SFC 0 "SET_CLK" or PG function). If another interface was configured as a time slave or as an NTP client, the time starts once the first time message frame has been received.

CPU as a time slave

If the CPU is a time slave on the S7-400 backplane bus, then the synchronization is carried out by a central clock connected to the LAN or by another CPU.

You can use a CP to forward the time to the S7-400. To do this, the CP (if it supports direction filtering) must be configured with the "from LAN to station" option in order to forward the time.

Time synchronization via the PROFINET interface

At the PROFINET interface, time synchronization is possible using the NTP method. The CPU is a client in this case.

You may configure up to four NTP servers. You can set the update interval between 10 seconds and 1 day. An NTP look-up of the CPU always takes place every 90 minutes for times in excess of 90 minutes.

If you synchronize the CPU using the NTP method, you should configure the CPU as the time master as the synchronization method in the S7-400. Select a synchronization interval of 10 seconds.

You can set a time zone in a CPU 41x-3 PN/DP via the SFC 100 or by an advanced time setting dialog (similar to the dialog of a Simatic Net CPs).

4.2.9 Data set routing

Availability

S7-400 CPUs as of firmware version 5.1 supports data set routing. The CPUs must also be configured in this or a higher firmware version for this.

Routing and data set routing

Routing is the transfer of data beyond network boundaries. You can send information from a transmitter to a receiver across several networks.

Data record routing is an expansion of the "standard routing" and is used by SIMATIC PDM, for example. The data sent through data record routing include the parameter assignments of the participating communication devices and device-specific information (for example, setpoint values, limit values, etc.). The structure of the destination address for data set routing depends on the data content, in other words, it is determined by the device for which the data is intended.

The field device itself does not need to support data set routing, since these devices do not forward the included information.

Data set routing

The following figure shows the engineering station accessing a variety of field devices. The engineering station is connected to the CPU via Industrial Ethernet in this scenario. The CPU communicates with the field devices via the PROFIBUS.

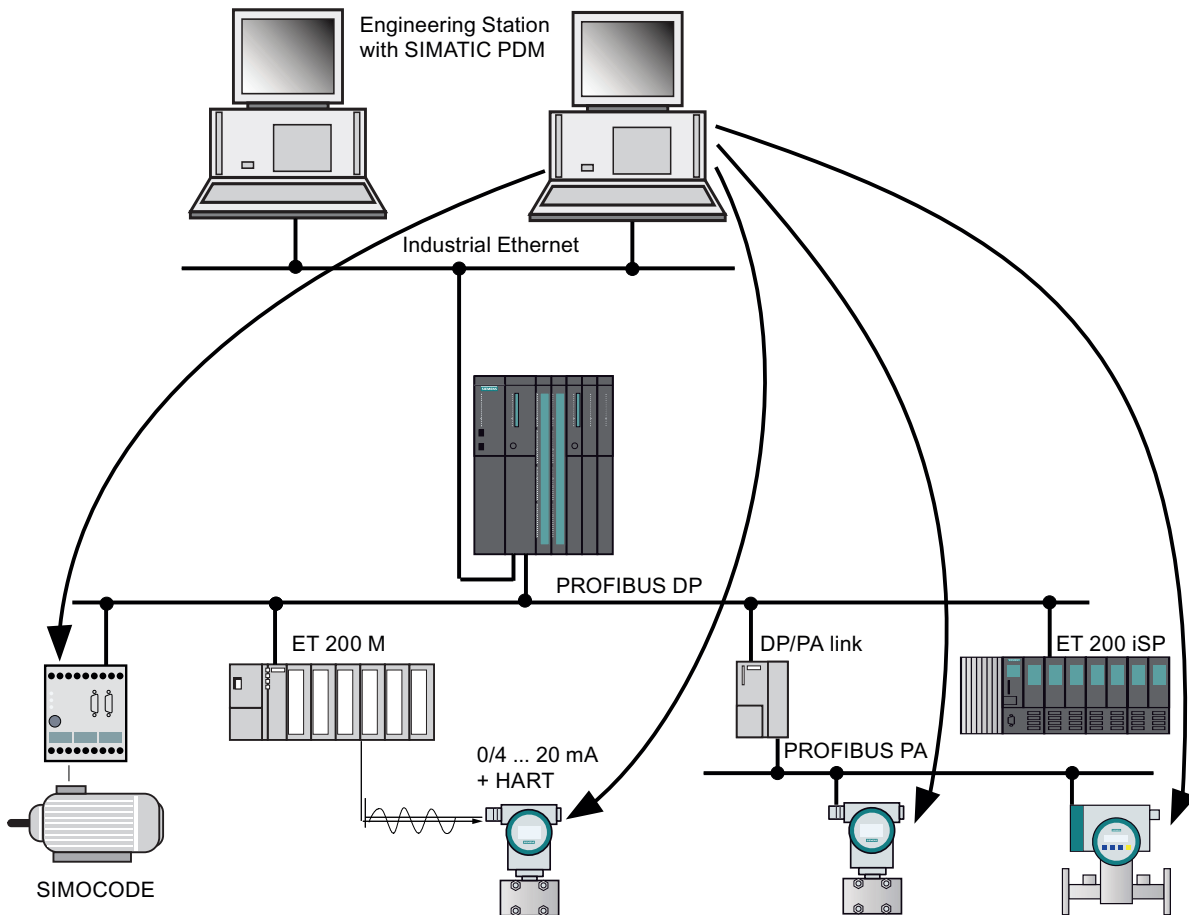

Figure 4-4 Data set routing

See also

You can find additional information on SIMATIC PDM in the *PDM V6.0 The Process Device Manager* manual.

4.3 SNMP network protocol

Availability

CPUs with a "PN/DP" suffix support the SNMP network protocol.

Properties

SNMP (Simple Network Management Protocol) is the standardized protocol for diagnostics of the Ethernet network infrastructure. In the office setting and in automation engineering, devices from many different manufacturers support SNMP on the Ethernet. SNMP-based applications can be operated on the same network in parallel to applications with PROFINET.

Configuration of the SNMP OPC server is integrated in the STEP 7 Hardware Configuration application. Already configured S7 modules from the STEP 7 project can be transferred directly. As an alternative to STEP 7, you can also perform the configuration with the NCM PC (included on the SIMATIC NET CD). All Ethernet devices can be detected by means of their IP address and/or the SNMP protocol (SNMP V1) and transferred to the configuration.

Use the profile MIB_II_V10.

Applications based on SNMP can be operated on the same network at the same time as applications with PROFINET.

Note

MAC addresses

During SNMP diagnostics, the following MAC addresses are shown for the ifPhysAddress parameter as of FW V5.1:

Interface 1 (PN interface) = MAC address

Interface 2 (port 1) = MAC address + 1

Interface 3 (port 2) = MAC address + 2

Diagnostics with SNMP OPC Server in SIMATIC NET

The SNMP OPC server software provides diagnostic and configuration functions for all SNMP devices. The OPC server uses the SNMP protocol to perform data exchange with SNMP devices.

All information can be integrated in OPC-compatible systems, such as the WinCC HMI system. This enables process and network diagnostics to be combined in the HMI system.

Reference

For further information on the SNMP communication service and diagnostics with SNMP, refer to the *PROFINET System Description*.

4.4 Open Communication Via Industrial Ethernet

Availability

CPUs with a "PN/DP" suffix support "open communication via Industrial Ethernet" (in short: open IE communication).

Functionality

The following services are available for open IE communication:

- Connection-oriented protocols:

Prior to data transmission connection-oriented protocols establish a logical connection to the communication partner and close this again, if necessary, after transmission is completed. Connection-oriented protocols are used when security is especially important in data transmission. A physical cable can generally accommodate several logical connections. The maximum job length is 32 KB.

The following connection-oriented protocols are supported for the FBs for open IE communication:

- TCP to RFC 793
- ISO on TCP according to RFC 1006

Note

ISOonTCP

For data communication with third-party systems via RFC1006, the connection partner must adhere to the maximum TPDU size (TPDU = Transfer Protocol Data Unit) negotiated in the ISOonTCP connection establishment.

- Connectionless protocols:

Connectionless protocols operate without a logical connection. There is also no establishing or terminating a connection to remote partner. Connectionless protocols transfer the data unacknowledged and thus unsecured to the remote partner. The maximum message frame length is 1472 bytes.

The following connectionless protocols are supported for the FBs for open communication by means of Industrial Ethernet:

- UDP according to RFC 768

How to use open IE communication

STEP 7 provides the following FBs and UDTs under "Communication Blocks" in the "Standard Library" to allow data to be exchanged with other communication partners:

- Connection-oriented protocols: TCP/ISO-on-TCP
 - FB 63 "TSEND" for sending data
 - FB 64 "TRCV" for receiving data
 - FB 65 "TCON", for connection setup
 - FB 66 "TDISCON", for disconnecting
 - UDT 65 "TCON_PAR" with the data structure for the configuration of the connection
- Connectionless protocol: UDP
 - FB 67 "TUSEND" for sending data
 - FB 68 "TURCV" for receiving data
 - FB 65 "TCON" for setting up the local communication access point
 - FB 66 "TDISCON" for resolving the local communication access point
 - UDT 65 "TCON_PAR" with the data structure for configuring the local communication access point
 - UDT 66 "TCON_ADR" with the data structure of the addressing parameters of the remote partner

Data blocks for parameterization

- Data blocks for parameterizing TCP and ISO-on-TCP connections

To be able to parameterize your connection at TCP and ISO-on-TCP, you must create a DB that contains the data structure of UDT 65 "TCON_PAR". This data structure contains all parameters you need to set up the connection. Such a data structure which you can group within a global data range is required for every connection.

Connection parameter CONNECT of FB 65 "TCON" reports the address of the corresponding connection description to the user program (for example, P#DB100.DBX0.0 byte 64).

- Data blocks for the configuration the local UDP communication access point

To configure the local communication access point, create a DB containing the data structure from the UDT 65 "TCON_PAR". This data structure contains the required parameters you need to set up the connection between the user program and the communication layer of the operating system

The CONNECT parameter of the FB 65 "TCON" contains a reference to the address of the corresponding connection description (for example, P#DB100.DBX0.0 Byte 64).

Note**Structure of the connection description (UDT 65)**

You must enter the interface to be used for communication in the parameter "local_device_id" in UDT 65 "TCON_PAR".

This is 16#5 for connection types TCP, UDP, ISO on TCP via the PN interface.

It is 16#0 for connection type ISO on TCP via a CP 443-1.

You can also use the default UDT 651 to 661 from "Standard Library" -> "Communication Blocks".

Job lengths and parameters for the different types of connection

Table 4- 6 Job lengths and "local_device_id" parameter

Message frame	CPU 41x-3 PN/DP	CPU 41x with CP 443-1
TCP	32 KB	-
ISO-on-TCP	32 KB	1452 bytes
UDP	1472 bytes	-
"local_device_id" parameter for the connection description		
Dev. ID	16#5	16#0

Establishing a communication connection

- Use with TCP and ISO-on-TCP

Both communication partners call FB 65 "TCON" to establish the connection. In the configuration, you specify which communication partner activates the connection, and which one responds to the request with a passive connection. To determine the number of possible connections, refer to your CPU's technical specifications.

The CPU automatically monitors and holds the active connection.

If the connection is broken, for example by line interruption or by the remote communication partner, the active partner tries to reestablish the connection. You do not have to call FB 65 "TCON" again.

FB 66 "TDISCON" disconnects the CPU from a communication partner, as does STOP mode. To reestablish the connection to have to call FB65 "TCON" again.

- Use with UDP

Both communication partners call FB 65 "TCON" to set up their local communication access point. This establishes a connection between the user program and operating system's communication level. No connection is established to the remote partner.

The local access point is used to send and receive UDP message frames.

Disconnecting a communication connection

- Use with TCP and ISO-on-TCP
FB 66 "TDISCON" disconnects the communication connection between the CPU and a communication partner.
- Use with UDP
FB 66 "TDISCON" disconnects the local communication access point, i.e., the connection between user program and communication level of operating system is interrupted.

Options for closing the communication connection

The following events cause the communication connection to be closed:

- You program the disconnection with FB 66 "TDISCON."
- The CPU state changes from RUN to STOP.
- At POWER OFF / POWER ON

Connection diagnostics

STEP 7 V5.4 SP5 or higher supports reading of additional information about the configured connections by selecting "Module state -> Communication -> Open communication over Industrial Ethernet".

Reference

For detailed information on the blocks described above, refer to the *STEP 7 Online Help*.

4.5 S7 connections

4.5.1 Communication path of an S7 connection

An S7 connection is established as a communication channel when S7 modules communicate with one another.

Note

Global data communication, point-to-point connection via CP 440, PROFIBUS DP, PROFINET CBA, PROFINET IO, Web and SNMP require no S7 connections.

Every communication link requires S7 connection resources on the CPU for the entire duration of this connection.

Thus, every S7 CPU provides a specific number of S7 connection resources. These are used by various communication services (PG/OP communication, S7 communication or S7 basic communication).

Connection points

An S7 connection between modules with communication capability is established between connection points. The S7 connection always has two connection points, one active and one passive:

- The active connection point is assigned to the module that establishes the S7 connection.
- The passive connection point is assigned to the module that accepts the S7 connection.

Any module that is capable of communication can thus act as an S7 connection point. At the connection point, the established communication link always uses one S7 connection of the module concerned.

Transition point

If you use the routing functionality, the S7 connection between two modules capable of communication is established across a number of subnets. These subnets are interconnected via a network transition. The module that implements this network transition is known as a router. The router is thus the point through which an S7 connection passes.

Any CPU with a DP or PN interface can be the router for an S7 connection. The number of S7 connections limits the number of routing connections.

4.5.2 Assignment of S7 connections

There are several ways to allocate S7 connections on a communication-enabled module:

- Reservation during configuration
- Assigning connections in the program
- Allocating connections during commissioning, testing and diagnostics
- Allocating connections to operator communication and monitoring (OCMS) services

Reservation during configuration

One connection resource each is automatically reserved on the CPU for PG and OP communication.

Connections must be configured (using NetPro) for the use of S7 communication. For this purpose, connection resources have to be available, which are not allocated to PG/OP or other connections. The required S7 connections are then permanently allocated for S7 communication when the configuration is uploaded to the CPU.

Assigning connections in the program

In S7 basic communication and in open Industrial Ethernet communication, it is the user program that establishes the connections. The CPU operating system initiates connection setup and the corresponding S7 connections are assigned.

Using connections for commissioning, testing and diagnostics

An active online function on the engineering station (PG/PC with STEP 7) occupies S7 connections for PG communication:

- The S7 connection reserved in the CPU for PG communication is assigned to the engineering station, that is, it only needs to be allocated.
- The S7 connection is only used, however, when the PG is communicating with the CPU.
- If all reserved S7 connection resources for PG communication are allocated, the operating system automatically assigns an available connection. If no more connection resources are available, the engineering station cannot communicate online with the CPU.

Allocating connection resources to OCMS services

S7 connection resources are allocated for the OP communication by an online function on the HMI station (OP/TP/... with *WinCC*) according to the following rules:

- If an S7 connection resource for OP communication is reserved in your CPU hardware configuration, it is assigned to this HMI station, that is, it only needs to be allocated.
- The S7 connection is permanently assigned.
- If all reserved S7 connections for OP communication are already allocated, the operating system automatically assigns an available connection. If no more connection resources are available, the HMI station cannot communicate online with the CPU.

Time sequence for allocation of S7 connection resources

When you configure your project in STEP 7, the system generates parameter assignment blocks which are read by the modules during startup. This allows the module's operating system to reserve or allocate the relevant S7 connection resources. This means, for example, that no operator station can access a reserved S7 connection resource for PG communication. If the CPU still has unreserved S7 connections, they can be used freely. These S7 connection resources are allocated in the order they are requested.

For PG and OP communication respectively, at least one connection resource is reserved by default.

Note

If there is only one free S7 connection left on the CPU, you can still connect a PG to the bus. The PG can then communicate with the CPU. The S7 connection is only used, however, when the PG is communicating with the CPU. If you connect an OP to the bus while the PG is not communicating, the OP can establish a connection to the CPU. Since an OP maintains its communication link at all times, in contrast to the PG, you cannot subsequently establish another connection via the PG.

4.6 Communication performance

Introduction

The aim of this description is to provide criteria which allow you to assess the effects of the various communication mechanisms on communication performance.

Definition of communication load

Communication load is the sum of jobs per second issued to the CPU by the communication mechanisms, plus the jobs and messages issued by the CPU.

Higher communication load increases the response time of the CPU, meaning the CPU takes more time to react to a job (such as a read job) or output jobs and messages.

Operating range

In every automation system there is a linear operating range in which an increase in communication load will also lead to an increase in data throughput. This will then result in reasonable response times which are acceptable for the automation task faced.

A further increase of communication load will push data throughput into the saturation range. At certain conditions the automation system could no longer be capable of processing the requested volume within the response time demanded. Data throughput reaches its maximum, and the response time rises exponentially; see the figures below.

Data throughput could actually be reduced by a certain amount due to additional internal loads inside the device.

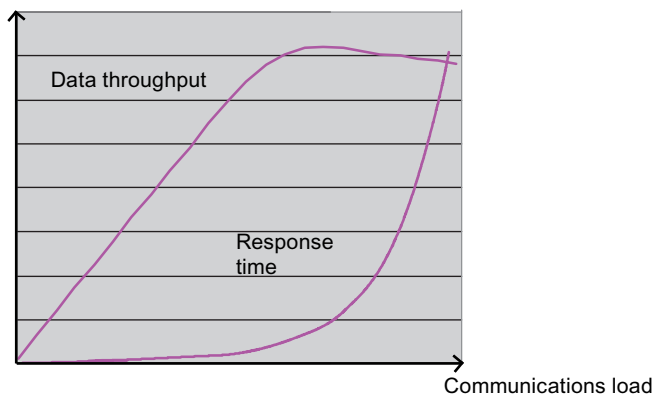

Figure 4-5 Communication load as a function of data throughput and response time (basic profile)

Which variables influence communication load?

The communication load is affected by the following variables:

- Number of connections/connected O&M systems
- Number of tags, or number of tags in images visualized on OPs or using WinCC.
- Communication type (O&M, S7 communication, S7 message functions, S5-compatible communication, ...)

The sections below show the factors having an influence on communication performance.

General issues in communication

Reduce the rate of communication jobs per second as far as possible. Utilize the maximum user data length for communication jobs, for example by grouping several tags or data areas in one read job.

Each job requires a certain processing time, and its status should therefore not be checked before it has been completed.

A freeware tool for the assessment of processing times (<http://support.automation.siemens.com/WW/view/en/25209605>) is available for download on the Internet.

Your calls of communication jobs should allow the event-driven transfer of data. Check the data transfer event only until the job has been completed.

Call the communication blocks sequentially and stepped down within the cycle, in order to obtain a balanced distribution of communication load.

You can by-pass the block call using a conditional jump if you do not transfer any user data.

A significant increase in communication performance between S7 components is achieved by using S7 communication functions, rather than S5-compatible communication functions.

Use S5-compatible communication (FB "AG_SEND", FB "AG_RECV", AP_RED) only if S7-components should communicate with non-S7-components. This is because S5-compatible communication functions (FB "AG_SEND", FB "AG_RECV", AP_RED) generate a significantly higher communication load. As another alternative to S5-compatible communication, you can use open IE communication as this generates a much lower communication load.

S7 communication (SFB 12 "BSEND" and SFB 13 "BRCV")

Do not call SFB 12 "BSEND" in the user program more often than the corresponding SFB 13 "BRCV" at the communication partner.

S7 communication (SFB 8 "USEND" and SFB 9 "URCV")

SFB 8 "USEND" should always be event-driven because this block may generate a high communication load.

Do not call SFB 8 "USEND" in the user program more often than the corresponding SFB 9 "URCV" at the communication partner.

SIMATIC OPs, SIMATIC MPs

Do not select a screen refresh cycle time of less than 1s, and increase it to 2 s as required.

Verify that all screen tags are requested within the same cycle time, in order to form an optimized group for read jobs.

OPC Server

If OPC is used to connect several HMI devices to an S7-400 for your visualization tasks, you should keep the number of OPC servers accessing the S7-400 as low as possible. OPC clients should always address a shared OPC server, which then fetches the data from the S7-400.

You can fine-tune the data exchange by using WinCC and its client/server concept.

Various HMI devices from third-party vendors support the S7 communication protocol. You should utilize this option.

4.7 Web server

4.7.1 Properties of the web server

Availability

CPUs with a "PN/DP" suffix have a Web server.

Activating the Web server

Before using the Web server for the first time you have to activate it in HW Config, see section Settings in HW Config, "Web" tab (Page 97)

Using the Web server

The Web server allows you to monitor your CPU on the Internet or on the Intranet of your company. This allows evaluation and diagnostics to be carried out remotely.

Messages and status information are visualized on HTML pages.

Web browser

You need a Web browser to access the HTML pages of the CPU.

Web browsers which are suitable for communication with the CPU:

- Internet Explorer (version 6.0 or later)
- Mozilla Firefox (V1.5 and higher)
- Opera (version 9.0 and higher)
- Netscape Navigator (version 8.1 or later)

Reading information via the Web server

The Web server can be used to read the following information from the CPU:

- Start page with general CPU information
 - Module name
 - Module type
 - State
 - Mode selector switch setting
 - Hardware order number
 - Hardware release version
 - Firmware release version
 - Plant identifier
 - Mode
- Content of the diagnostics buffer
- Variable table
 - You can monitor up to 50 variable tables with a of maximum 200 variables. Select the variable tables on the relevant Web site, see section Variable tables (Page 133)
- Variable status
 - You can monitor up to 50 variables after specifying their address.
- Module state
 - The status of a station is indicated using symbols and comments.
- Messages (message state ALARM_S, ALARM_SQ, ALARM_D, ALARM_DQ) without option of acknowledgement

- Information about Industrial Ethernet
 - Ethernet MAC address
 - IP address
 - IP subnet address
 - Default router
 - Auto negotiation mode ON/OFF
 - Number of packets sent/received
 - Number of faulty packets sent/received
 - Transmission mode (10 Mbps or 100 Mbps full duplex)
 - Link status
- Topology of the PROFINET nodes
 - The configured PROFINET nodes of a station are displayed.

Note

Incorrect display

Delete all cookies and temporary Internet files from your PC / programming device if incorrect data is output while you are working with the Web server.

Activating the Web server

The Web server is activated with its factory settings. It is deactivated in HW Config with its basic configuration. You can activate the Web server in HW Config with the command "CPU -> Object Properties -> Web".

Web access to the CPU via PG/PC

Proceed as follows to access the Web server:

1. Connect the programming device/PC to the CPU via the Ethernet interface.
2. Open the Web browser (for example, Internet Explorer).

Enter the IP address of the CPU in the "Address" field of the Web browser in the form <http://a.b.c./> e.g. http://192.168.0.1/

The CPU start page appears. From the start page, you can navigate to additional information.

Web access to the CPU via PDA

You can also access the web server using a PDA. You can select a compact view for this. The procedure is as follows:

1. Connect the PDA to the CPU via the PROFINET interface.
2. Open the Web browser (for example, Internet Explorer).

Enter the IP address of the CPU in the "Address" field of the Web browser in the format <http://a.b.c.d/basic> e.g. http://192.168.0.1/basic

The start page of the CPU opens. From the start page, you can navigate to additional information.

HMI devices operating with Windows CE operating system V 5.x or earlier process CPU information in a browser specially developed for Windows CE. The information appears in a simplified format in this browser. The figures in this manual show the more detailed format.

Security

The Web server by itself does not provide any security functions for access protection and user management. Protect your web-compliant CPUs against unauthorized access by means of a firewall.

4.7.2 Settings in HW Config, "Web" tab

Requirements

You have opened the CPU properties dialog in HW Config.

To utilize the full functionality of the Web server, make the following settings in the "Web" tab:

- Activate the Web server
- Set the language for Web
- Activate automatic update
- Display classes of the messages

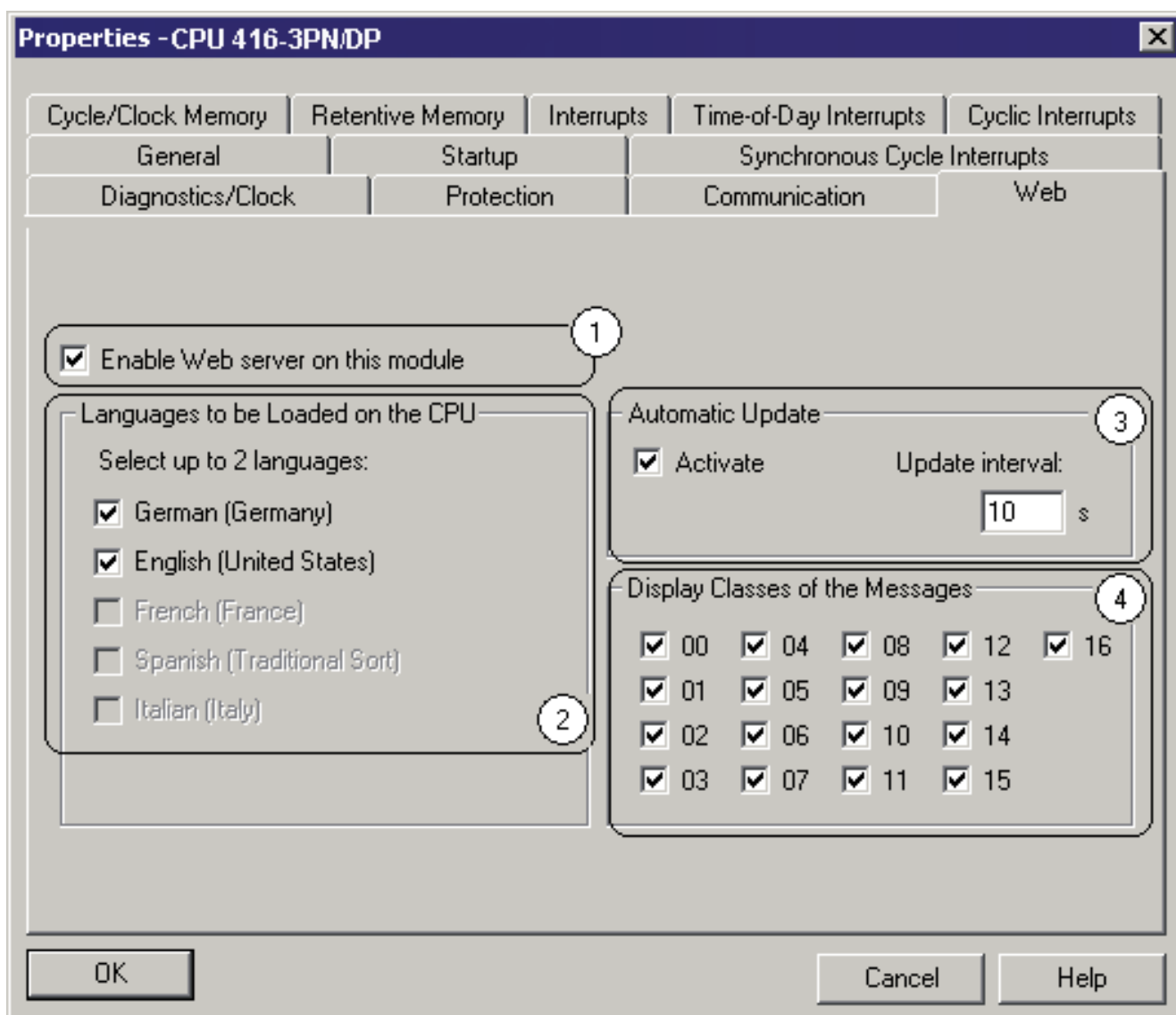

Figure 4-6 Settings in HW Config

① Activate the Web server

The web server is deactivated in the basic configuration in HW Config. Activate the Web server in HW Config.

In the CPU properties dialog:

- Check the "Activate Web server on this module" check box

② Set the language for Web

Select up to two languages for the Web from the languages installed for display devices.

In the CPU properties dialog:

- Check the "Activate Web server on this module" check box
- Select up to two languages for the Web.

Note

If you activate the Web server and do not select a language, messages and diagnostics information will be displayed in hexadecimal code.

③ Activate automatic update

To enable automatic updates, proceed as follows:

- Set the "Activate" check box at "Automatic update" in the properties dialog of the CPU.
- Enter the update interval.

Note

Update time

The activation interval set in HW Config is the shortest update time.

If the CPU is heavily loaded during operation, e.g. due to many PROFINET interrupts or a large number of extensive communication jobs, the update of the Web pages may be delayed considerably for the duration of this high CPU load.

④ Display classes of the messages

All message display classes are activated in the basic configuration in HW Config. The messages for the selected display classes are displayed at a later time on the "Messages" Web page. Messages which do not belong to the selected display classes are output in hex code instead of plain text.

How to configure the message classes:

- For "Report system error" in HW Config at "Options > Report system error".
- For block-specific messages in STEP 7

Information about configuring message texts and classes can be found in STEP 7.

Note

Reducing memory requirements of the Web SDBs

You can reduce memory requirements of the Web SDBs by selecting only the messages to be filled in the Web SDB.

4.7.3 Language settings

Introduction

The Web server provide information in the following languages:

- German (Germany)
- English (United States)
- French (France)
- Italian (Italy)
- Spanish (traditional sorting)
- Chinese
- Japanese

Note

Web server with Chinese/Japanese Windows

When you use the Web server of the CPU together with Chinese/Japanese Windows, you have to manually set the coding of the Internet browser to: View / Coding / Unicode (UTF-8)

What you need to display texts in different languages

Language settings to be made in STEP 7 in order to ensure proper output of data in the selected language:

- Set the language for display devices in SIMATIC Manager
- Set the regional Web language in the properties dialog of the CPU

Setting the language for display devices in SIMATIC Manager

Select the language for display devices in SIMATIC Manager:
"Options > Language for display devices"

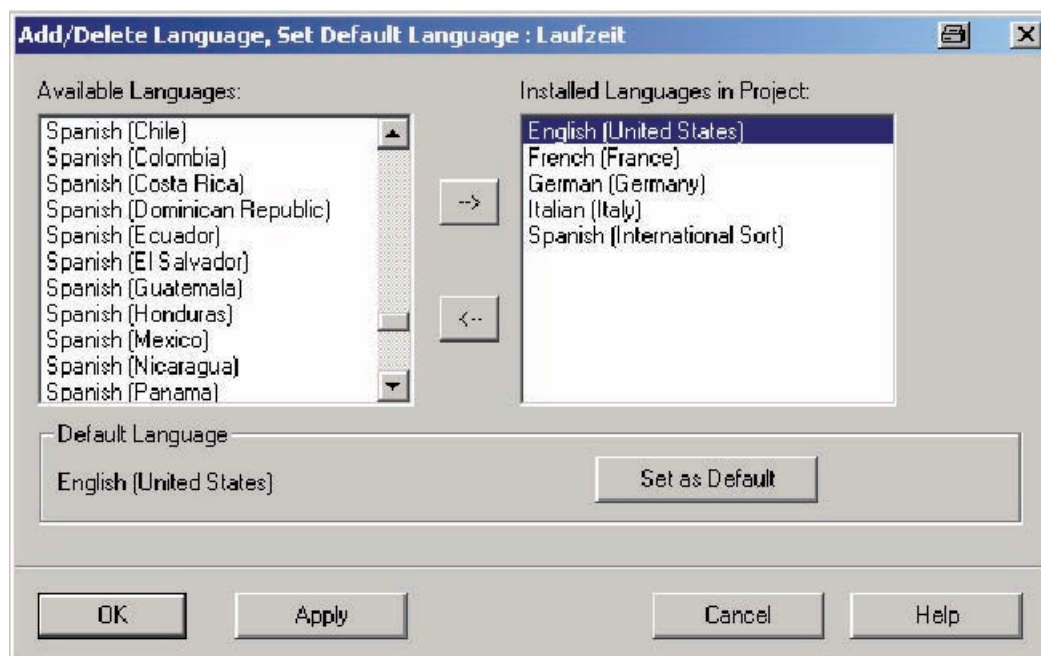

Figure 4-7 Example for selecting the display device language

Setting the language for Web

Select up to two languages for the Web from the languages installed for display devices.

Open the CPU properties dialog box:

- Check the "Activate Web server on this module" check box
- Select up to two languages for the Web.

Note

If you activate the Web server and do not select a language, messages and diagnostic information will be displayed in hexadecimal code.

4.7.4 Updating and saving information

Screen content refresh status and printing

Screen content

Automatic refresh is deactivated in the basic configuration in HW Config. This means that the screen of the Web server outputs static information.

Refresh the Web pages manually using the <F5> function key or the following icon:



Printing

Data output to the printer always return the current CPU information. The printed information may therefore be more up to date than the screen contents.

Print Web pages using the following icon:



Filter settings have no effect on the print-out, The print-out always shows the entire contents of the message buffer.

Deactivating automatic refresh for individual Web pages

To deactivate automatic refresh for a Web page for a short time, select the following icon:



Enable automatic refresh again using the <F5> function key or the following icon:



Note

Update time if CPU is heavily loaded

If the CPU is heavily loaded during operation, e.g. by a high number of PROFINET interrupts or by a large number of extensive communication jobs, the update of the Web pages may be delayed considerably for the duration of this high CPU load.

Saving messages and entries of the diagnostics buffer

Messages and diagnostics buffer entries can be saved to a csv file. The displayed 250 entries of the diagnostics buffer are saved. Use the following symbol to save the data.



A dialog box opens in which you can enter the file name and target directory.

To prevent incorrect display of the data in Excel, do not open the csv file with double-click. Import the file in Excel by selecting the "Data" and "Import external data" menu command.

Select the "Separated" file type and "Unicode UTF-8" as file source. Select the comma separator and the text recognition character ".

4.7.5 Web pages

4.7.5.1 Start page with general CPU information

Going online to the Web server

You log on to the Web server by entering the IP address of the configured CPU in the address bar of the Web browser (example: `http://192.168.1.158`). The connection opens with the "Intro" page.

Introduction

The screenshot below shows the first page (Intro) called by the Web server.



Figure 4-8 Intro

Click the ENTER link to go to the Web server pages.

Note

Skipping the Intro Web page

Set the "Skip Intro" check box in order to skip the Intro. The Web server will now directly open its start page. You can undo the "Skip intro" setting by clicking the "Intro" link on the start page.

Start page

The start page displays information as shown in the picture below.

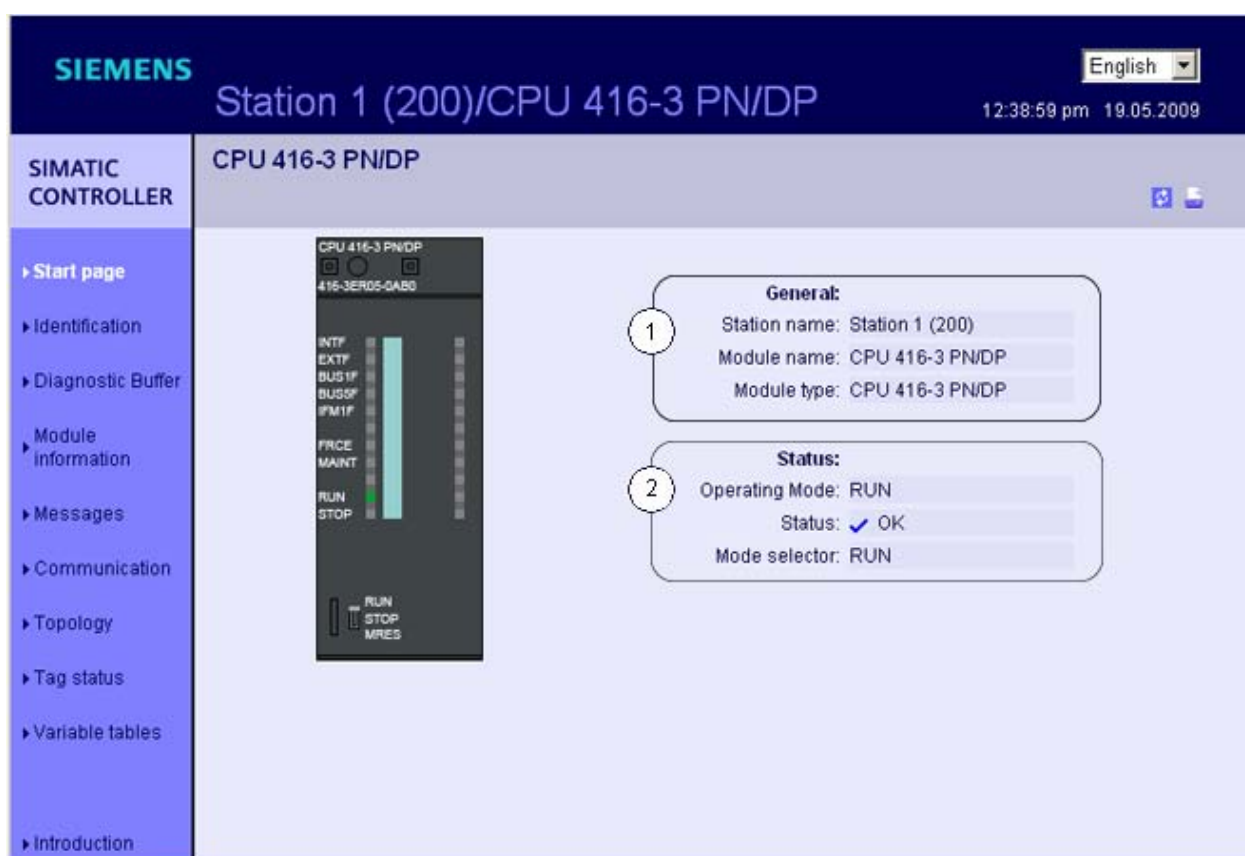

Figure 4-9 General Information

The CPU image with LEDs displays the actual CPU status at the time of data request.

① "General"

This group displays information about the CPU running the Web server to which you are currently logged on.

② "Status"

The "Status" field displays CPU status information which is valid when requested.

4.7.5.2 Identification

Specifications of the CPU

The identification Web page displays specifications of the CPU.



Figure 4-10 Identification

① Identification

The "Identification" field contains the plant and location ID, and the serial number. You can configure the plant and location IDs in HW Config in the CPU properties dialog in the "General" tab.

② Order number

You can find the order numbers of the hardware in the field "Order number".

③ Version

You can find the hardware and firmware versions in the "Version" field.

4.7.5.3 Diagnostics buffer

Diagnostics buffer

The browser displays the content of the diagnostics buffer on the diagnostics buffer Web page.

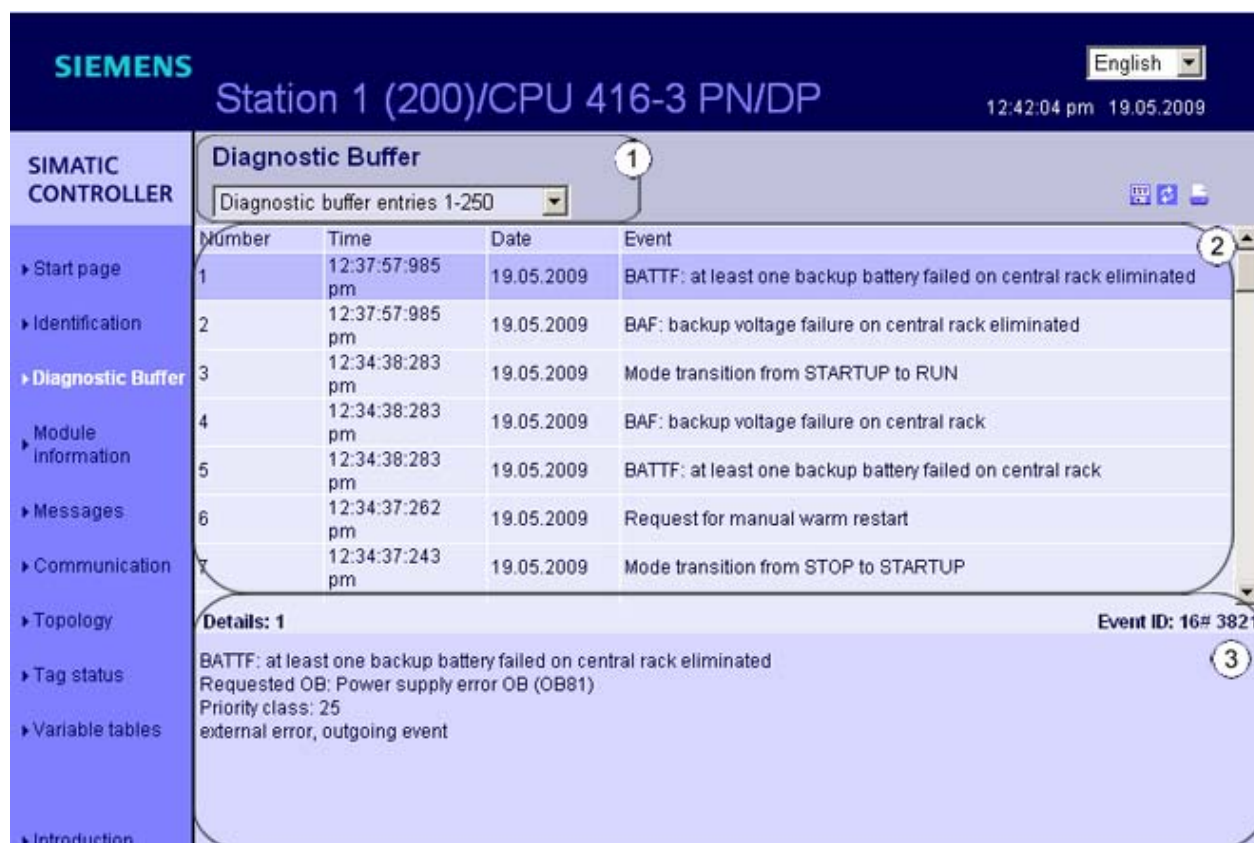

Figure 4-11 Diagnostics buffer

Requirements

The Web server is activated, languages are set, and the project is compiled and downloaded in STEP 7.

① Diagnostics buffer entries 1-250

The diagnostics buffer can save up to 3200 messages. Select an buffer input interval from the list. Each interval comprises 250 entries. Note that the program does not displays all the buffer entries in RUN for reasons that include performance.

② Events

The "Events" fields displays the diagnostics event and the corresponding date and time stamp.

③ Details

This field outputs detailed information about a selected event.

Select the corresponding event from the ② "Events" field.

Configuration

Configuration procedure:

1. Open the "Object properties" dialog box from the shortcut menu of the corresponding CPU.
2. Select the "Web" tab, and then activate the "Activate Web server on this module" check box.
3. Select up to two languages to be used to display plaintext messages.
4. Save and compile the project and download the configuration data to the CPU.

Special features when changing languages

You can change the language, for example, from German to English, by clicking the object in the upper right corner. If you select a language you have not configured the program shows a hexadecimal code instead of plain text information.

4.7.5.4 Module state

Requirements

- You made the following settings in HW Config:
 - Web server activated
 - Language settings
 - "Report system error" generated and activated.
- You compiled the project using STEP 7 HW Config, loaded the SDB container and the user program (particularly the user program blocks generated by "Report system error")
- The CPU is in RUN mode

Note

"Report system error"

- **Duration of display:** Depending on the plant configuration, the display "Report system error" may take some time to create the startup evaluation of the state of all the configured I/O modules and I/O systems. There is no concrete display of the status on the "Module state" page during this time. A "?" is displayed in the "Error" column.
 - **Dynamic response:** "Report system error" must be called cyclically at least every 100 ms.
The call may either take place in OB 1, or if the cycle time is more than 100 ms in the cyclic interrupt OB 3x (≤ 100 ms) and in the restart OB 100.
 - **Diagnostics support:** In the "Report system error" dialog box, the "Diagnostics status DB" check box must be selected in the "Diagnostics support" tab and a DB number entered. This check box is normally selected by default for configured Web servers. However, during migration of old projects it may be necessary to select this check box manually.
 - **Restart:** After the CPU has been restarted, the module state is displayed on expiration of a delay time of some seconds, depending on the station configuration.
-

Module state

The status of a station is displayed on the "Module state" page using symbols and comments.

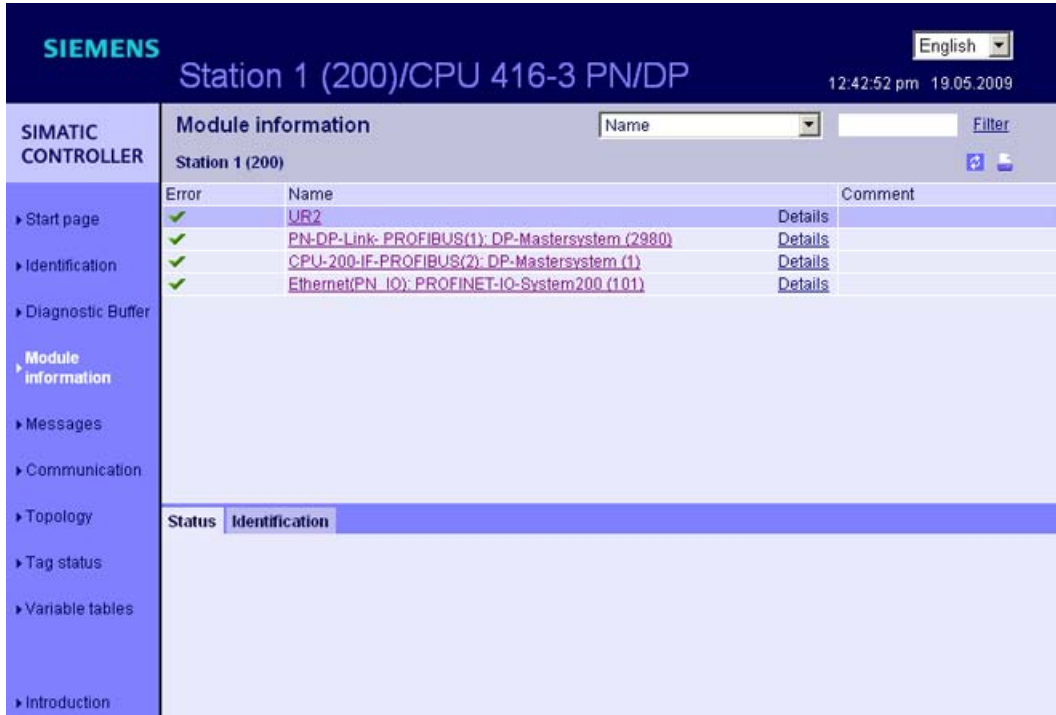









Figure 4-12 Module state

Meaning of symbols

Symbol	Color	Meaning
	green	Component OK
	gray	Disabled PROFIBUS slaves or PROFINET devices
	black	Component not available / unable to determine state "Unable to determine state" is, for example, always displayed in STOP mode of the CPU, or during the startup evaluation of "Report system error" for all configured I/O modules and I/O systems after restart of the CPU. However, this state can also be displayed temporarily at runtime for all modules in the event of a surge of diagnostics interrupts.
	green	Maintenance required
	yellow	Maintenance demanded
	red	Fault - component failed or faulty
	-	Fault at lower module level

Navigation to other module levels

The state of individual modules is displayed when you navigate to further module levels:

- Go to the next higher module level using the link in the title line
- Go to the next lower module level using the link in the name

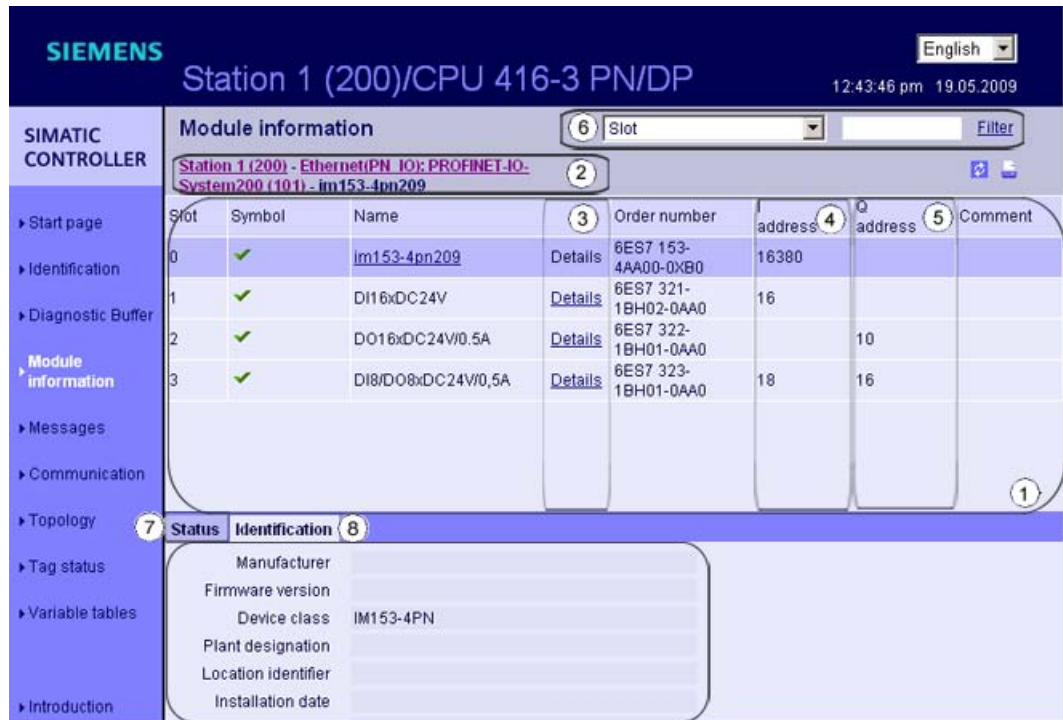

Figure 4-13 Module state

Requirements

The Web server is activated, languages are set, and the project is compiled and downloaded in STEP 7.

Note

State of the AS-i slaves

The state of AS-i slaves is not displayed on the "Module state" page. Only the state of the AS-i link is displayed.

① "Module state"

The table contains information about the rack, the nodes, the DP master system and the individual modules of the station relating to the selected level.

The requirement for this is that the function "Report system errors" has been configured for the CPU or the station and that the modules generated have been loaded in the CPU.

② "Display of module levels"

The link in the title line takes you to the "module state" of the next higher module level.

③ "Details"

The "Details" link provides you with information on the selected module in the "Status" and "Identification" tabs.

④ "IP address"

You can use the link to access the Web server of the selected, configured devices.

⑤ Topology

The "Topology" and "Module status" Web pages are linked. Click "Topology" of the selected module to automatically jump to this module in the graphic view of the "Topology" web page. The module appears in the visible area of the "Topology" web page and the device head of the selected module flashes for a few seconds.

⑥ "Filter"

You can sort the table by certain criteria.

Use the dropdown list to view only the entries of the selected parameter. Enter the value of the selected parameter in the input box and then click "Filter".

1. Select, for example, the "Name" parameter from the drop-down list box.
2. Click "Filter".

The filter criteria are also retained when you update a page.

⑦ "Status" tab

The tab contains information on the status of the selected module:

⑧ "Identification" tab

The tab contains data on the identification of the selected module.

Note

"Identification" tab

This tab displays only the data configured offline, not the online module data.

4.7.5.5 Alarms

Messages

The browser displays the content of the message buffer on the Messages Web page. The messages cannot be acknowledged on the web server.



Figure 4-14 Messages

Requirements

The message texts were configured in the user-specific languages. For information about configuring message texts refer to STEP 7 and to the Internet address: (<http://support.automation.siemens.com/WW/view/en/23872245>)

① Filter

This functionality allows you to select specific information from this page.

Use the corresponding list to view only the entries of the selected parameter. Enter the value of the selected parameter in the input box and then click "Filter".

To view all alarms with "incoming" status, for example:

1. Select the "Status" parameter from the list.
2. Enter the "incoming" text in the input box.
3. Click "Filter".

The filter criteria are also retained when you update a page. Filter settings have no effect on the print-out. A printout always contains the entire content of the message buffer.

② Messages

CPU messages are displayed in chronological order, including the **date** and **time**.

The **message text** parameter is an entry which contains the message texts configured for the corresponding fault definitions.

Sorting

You can also view the parameters in ascending or descending order. Click in the column header of one of the parameters.

- Message number
- Date
- Time
- Message Text
- State
- Acknowledgment

The messages are returned in chronological order when you click the "Date" entry. Incoming and outgoing events are output at the **Status** parameter.

③ Message number details

You can view detailed message information in this info field. To do this, select a message the details of which you are interested.

Special features when changing languages

You can change the language, for example, from German to English, by clicking the object in the upper right corner. If you select a language or corresponding message texts you have not configured the program shows a hexadecimal code instead of plain text information.

4.7.5.6 Communication

"Parameters" tab

The "Parameters" tab ① of this Web page contain a summary of information about the integrated PROFINET interface of the CPU.

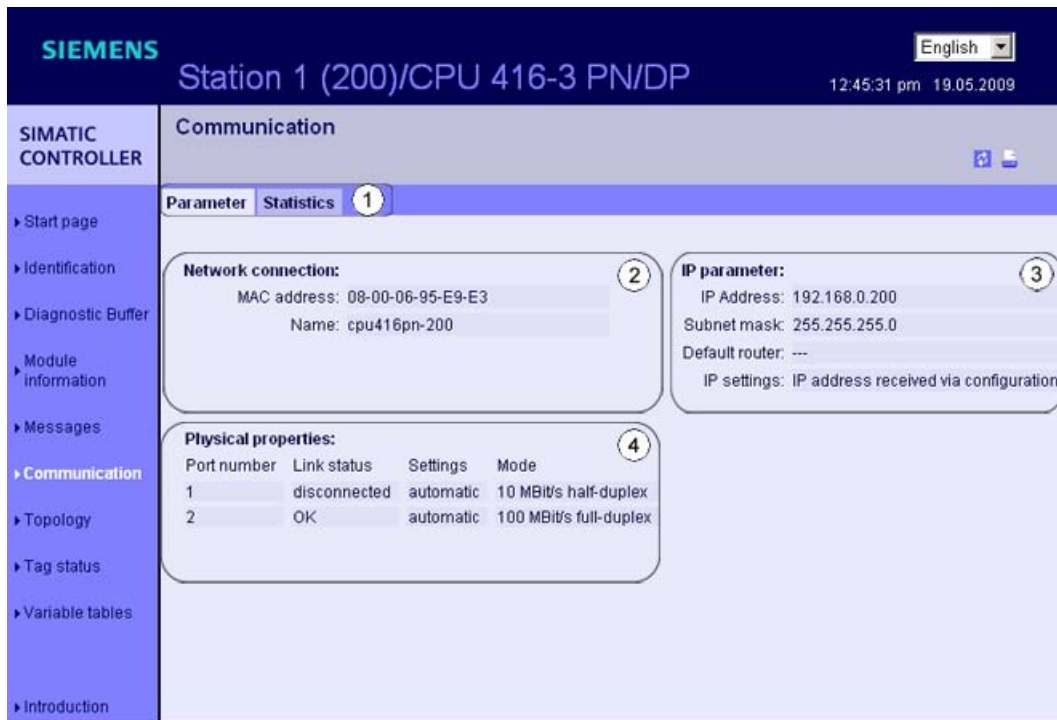

Figure 4-15 Parameters of the integrated PROFINET interface

② Network connection

This page displays information for the identification of the integrated PROFINET interface of the corresponding CPU.

③ IP parameters

Information about the configured IP address and number of the subnet in which the corresponding CPU is networked.

④ Physical properties

You can find the following information in the "Physical properties" field:

- Port number
- Link status
- Settings
- Mode

Note

Updating data

The data you see in the HTML browser are only automatically updated if you activated automatic update in HW Config. Otherwise, you can view the current data by updating the view in the HTML browser at regular intervals (Update button).

"Statistics" tab

Information about the quality of data transfers is available in the ① "Statistics" tab.



Figure 4-16 Data transfer numbers

② Data packets since

This shows the time at which the first data packet was sent or received after the last POWER ON / memory reset.

③ "Total statistics - Data packets sent"

The quality of the data transmission on the transmission line can be determined from the key figures in this info box.

④ "Total statistics - Data packets received"

The quality of the data transmission on the reception line can be determined from the key figures in this info box.

"Statistics Port 1/Port 2 - Data packets sent"

The quality of the data transmission on the transmission line can be determined from the key figures in this info box.

"Statistics Port 1/Port 2 - Data packets received"

The quality of the data transmission on the reception line can be determined from the key figures in this info box.

4.7.5.7 Topology

Topology of the PROFINET nodes

The "Topology" Web page shows the configured and non-configured PROFINET nodes of a station, which are nevertheless accessible through neighbor recognition.

There are three views:

- Graphic view. Two display options are available in this view.
 - **Actual topology:** Shows the actual topological structure of the configured PROFINET devices and the determined direct neighboring non-configured PROFINET devices. (display of the neighborhood relation, as far as this can be determined)
 - **Saved topology:** A saved actual topology can be adopted as setpoint topology, making it easier to diagnose changes in the actual topology. The topological assignment of failed PROFINET devices remains recognizable in this view.

Note

New non-configured directly adjacent PROFINET devices are only shown in the actual topology.

Note

Display of the actual topology

The actual topology is always shown in the following scenarios:

- When the "Topology" Web page is called via the navigation bar
 - When switching from the "Module status" Web page, overview of PNIO devices, to the "Topology" web page via the "Topology" link
-

- Tabular view
- Status overview

The views can be printed out. Use your browser's print preview function before printing and correct the format if necessary.

Topology - Graphical view

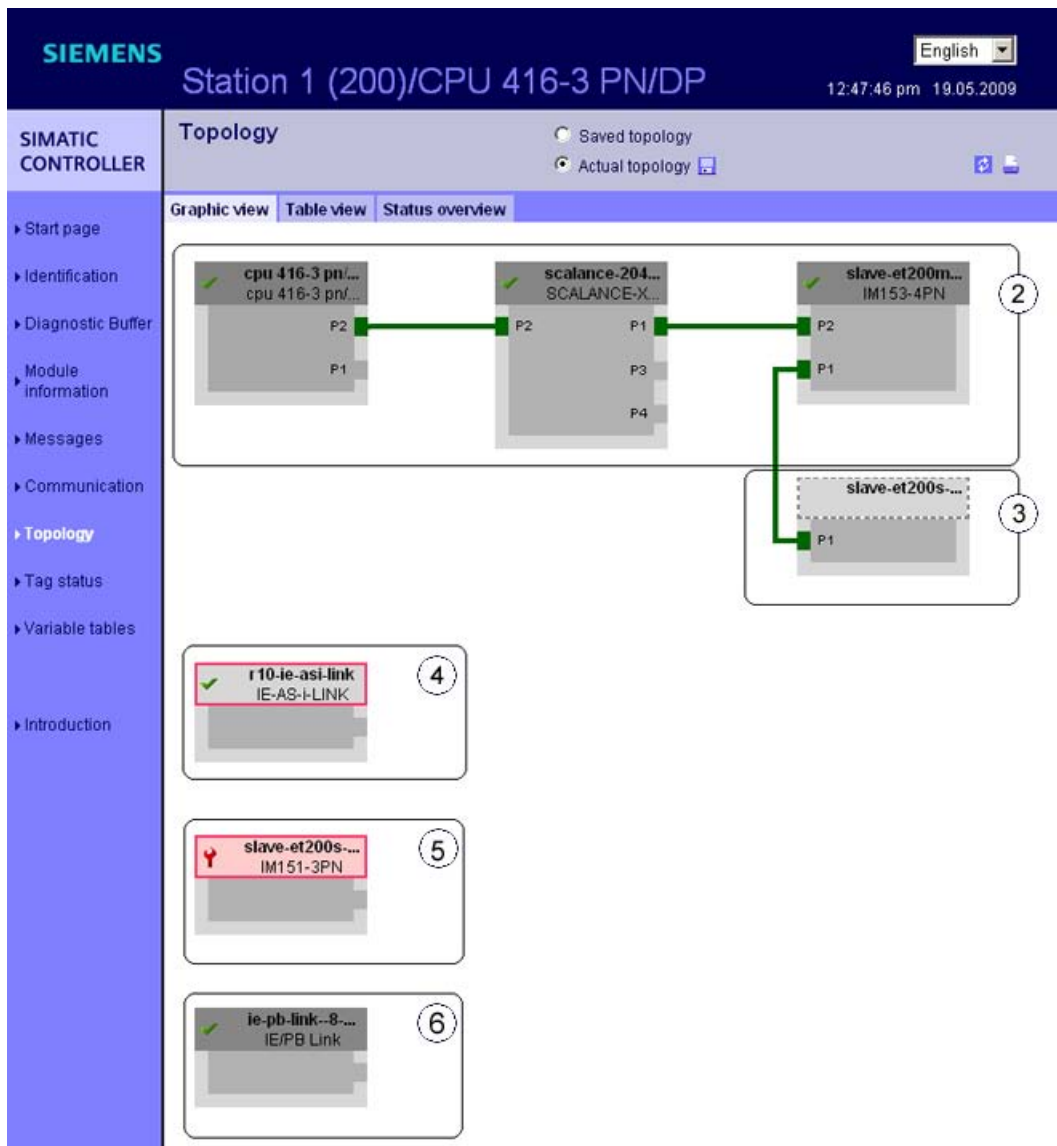

Requirements

You have activated the web server, set up the language, and compiled the project in HW Config and downloaded it.

① "Saved topology" and "Actual topology"

The "Actual topology" shows the status of the actual device interconnection. You can use the following symbol to save the "Actual topology":



The connection status you just saved is displayed when you switch to "Saved topology". If a device should fail in the meantime, the following happens:

- This device remains in the same place in the "Saved topology" view
- In the "Actual topology" view, the device is displayed separately in the bottom area.

In both cases the failed device is indicated by a red bordered device head and red wrench.



- Non-configured, directly adjacent PROFINET devices that were saved, remain in the same place in the "Saved topology" view when they fail and are displayed with red dashed line device head. Directly adjacent PROFINET devices added are not recognized in the display of the "Saved topology" and are not shown.

Ports which were interchanged are not marked in color.

Note

Retentivity of the "Saved topology" after POWER ON / OFF/ and memory reset

The "Saved topology" is not retentive.

② Configured and accessible PROFINET nodes

Configured and accessible PROFINET nodes are displayed in dark gray. Green connections show through which ports the PROFINET nodes of a station are connected.

② Non-configured and accessible PROFINET devices

PROFINET devices that are not configured but can be accessed directly ("neighboring stations") are displayed in light gray and with a dashed line.

④ Visualization of faulty neighbor relationships

The nodes whose neighbor relationships are incomplete or can only be read out with an error are displayed in light gray with a red frame.

Note

Displaying faulty neighbor relationships

A firmware update of the affected component is required.

⑤ Configured, but unavailable PROFINET nodes

The configured but inaccessible PROFINET nodes are displayed in the lower section in pink, with a red frame and device number.

⑤ Configured node without neighbor relationships

Nodes for which no neighbor relationship can be determined are displayed in dark gray and only with the device number:

- IE/PB links and the PROFIBUS nodes connected to them
- PROFINET devices that do not support LLDP (neighbor recognition)

The PROFINET nodes can be identified by the device numbers in HW Config.

Deactivated nodes

Deactivated nodes are shown in light gray.

Link between the "Topology" and "Module state" Web pages

The "Topology" and "Module status" Web pages are linked. In the topology view, click the head of the select module to jump automatically to this module in the "Module status" Web page.

See also chapter Module state (Page 109).

Topology - Tabular view

The tabular view always shows the actual topology.







Port	Status	Name	Module type	Port	Partner port	Port
		cpu 416-3 pn/dp	cpu 416-3 pn/dp			
		g6-s1-et200s	IM151-3PN	port-001	x204-202	port-001
		im151-3aa20-207	IM151-3PN	port-002		
		et 200m (im153-2)	et 200m (im153-2)	port-001	x204-202	port-003
		im153-4pn209	IM153-4PN	port-002	im153-4pn209	port-001
		im153-4pn209	IM153-4PN	port-001	im151-3aa20-207	port-002
		g6s1-link	IE/PB Link	port-002		
		x204-202				
				port-001	cpu 416-3 pn/dp	port-002
				port-003	im151-3aa20-207	port-001

Figure 4-18 Topology - Tabular view

Meaning of the symbols relating to the status of the PROFINET nodes

Symbol	Meaning
	Configured and available PROFINET nodes
	Non-configured and available PROFINET nodes
	Configured, but unavailable PROFINET nodes
	Nodes for which neighbor relationships cannot be determined, or for which the neighbor relationship could not be read out completely, or only with errors

Meaning of the symbols relating to the module state of the PROFINET nodes

Symbol	Color	Meaning
	green	Component OK
	gray	Disabled PROFIBUS slaves or PROFINET devices Requirement for support: <ul style="list-style-type: none"> • As of CPU 41x-3 PN/DP, V5.3 and STEP 7 V5.4 + SP5 • Activating/deactivating the PROFIBUS slaves and PROFINET IO devices with SFC12 Mode 3/4
	black	Component not available / unable to determine state "Unable to determine state" is, for example, always displayed in STOP mode of the CPU, or during the startup evaluation of "Report system error" for all configured I/O modules and I/O systems after restart of the CPU. However, this state can also be displayed temporarily at runtime for all modules in the event of a surge of diagnostics interrupts.
	green	Maintenance required
	yellow	Maintenance demanded
	red	Fault - component failed or faulty
	-	Fault at lower module level

Topology - Status overview

The "Status overview" shows a clear representation of all PN IO devices / PROFINET devices (without connection relationships) on one page. A quick error diagnostics is possible based on the symbols that show the module states.

Here, too, there is a linking of the modules to the "Module status" Web page.

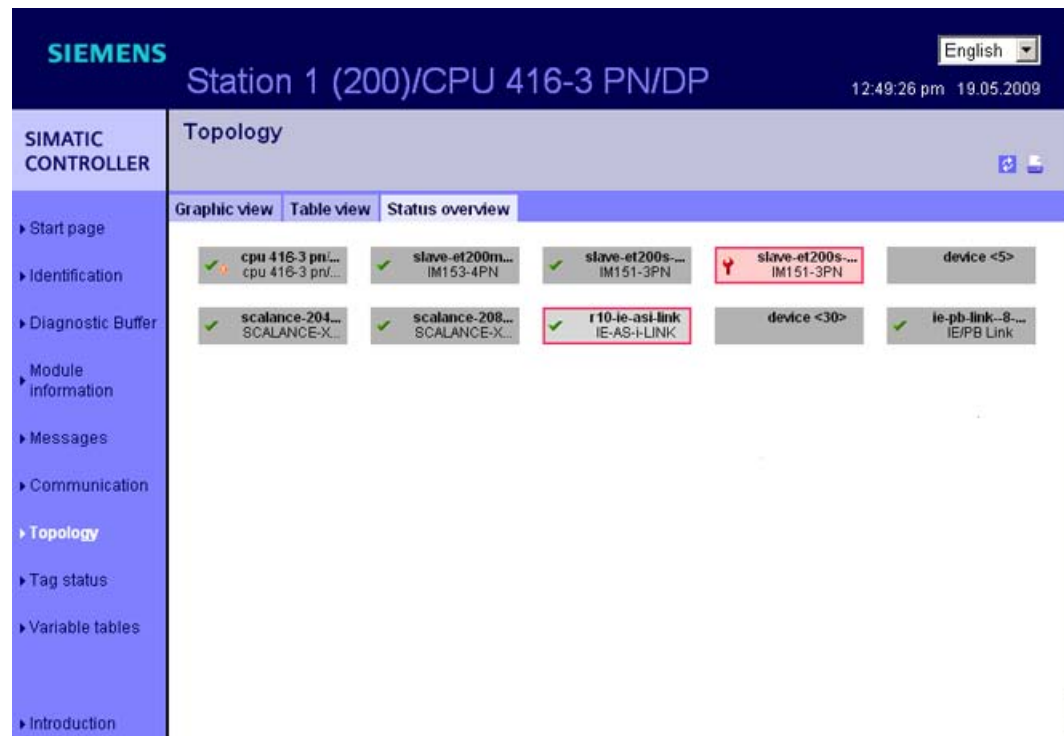

Figure 4-19 Topology - Status overview

4.7.5.8 Examples of individual topology views

Here we show and explain with examples how the various topology views can appear.

Requirements

CPU 414-3 PN/DP, V5.3 and STEP7 V5.4 + SP5 are prerequisite.

"Actual topology" is OK

If all configured devices are topologically accessible, save the view. If no topology was ever saved up until now, the button for "Saved topology" is grayed out.

When you perform the save operation the topology connections are "frozen". The view remains in the "Actual topology".

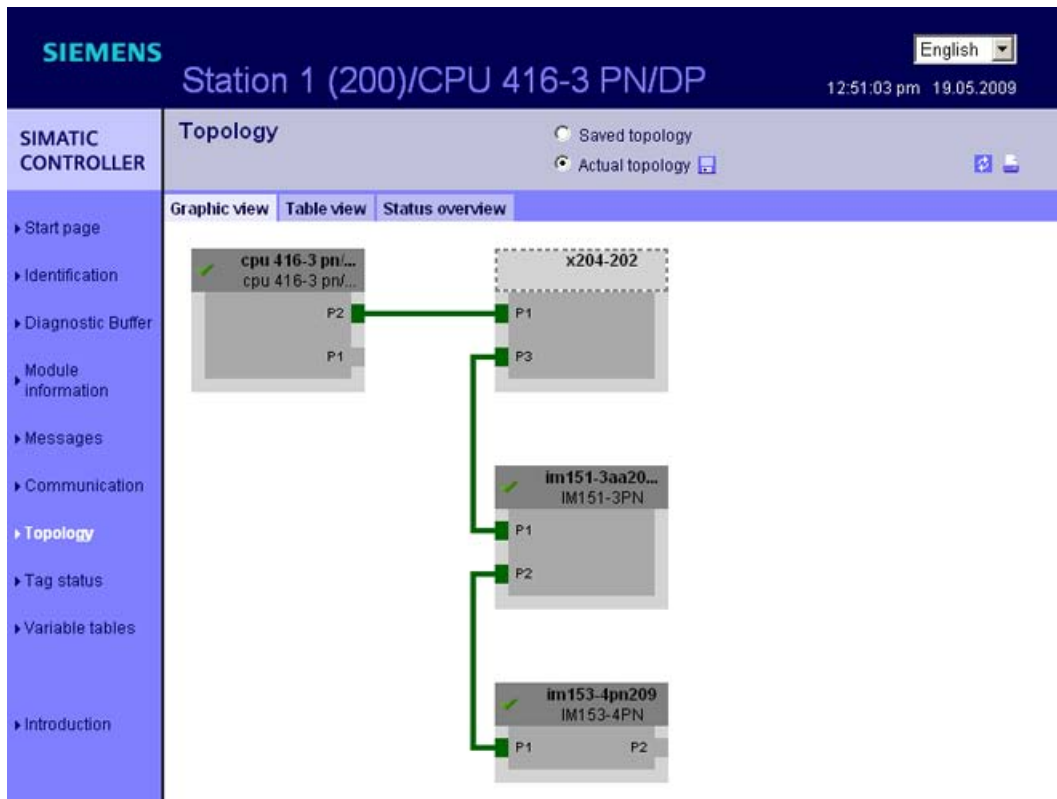

Figure 4-20 "Actual topology" is OK

"Saved topology" is OK

Now switch to the "Saved topology". If **no** device has failed in the meantime, the "Saved topology" looks identical to the "Actual topology".

The save button is grayed out in the "Saved topology".

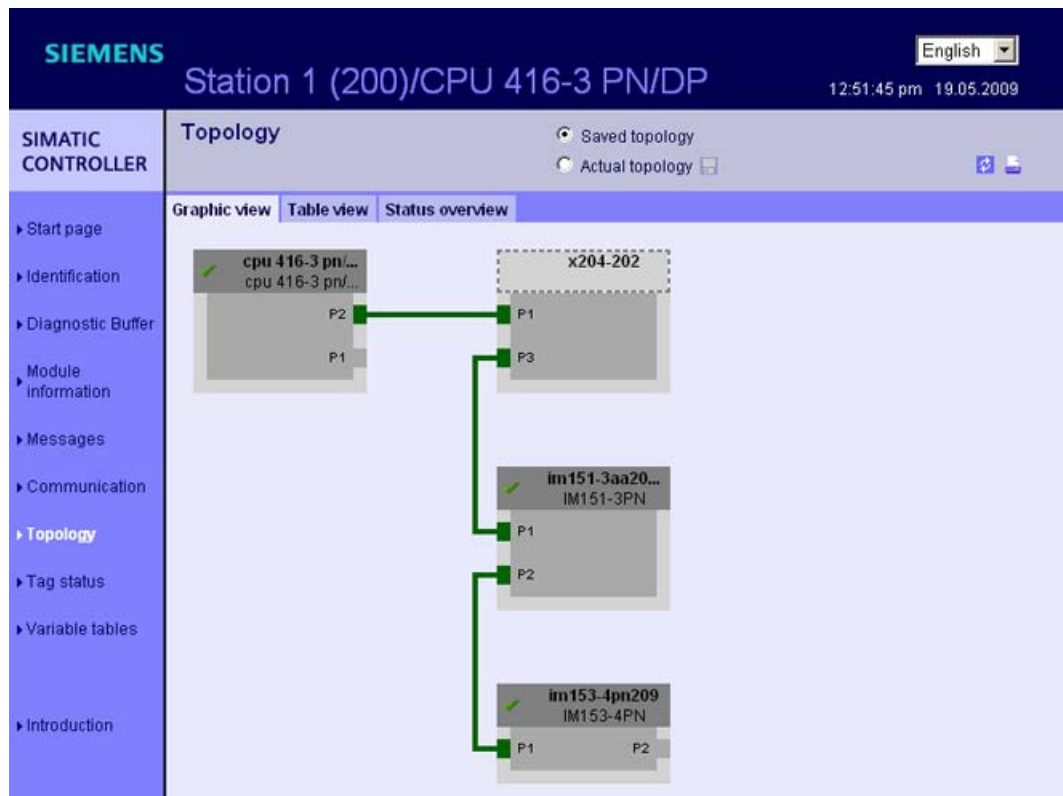

Figure 4-21 "Saved topology" is OK

"Saved topology" with failed device

If a device has failed in the meantime, this device remains in the same place in the "Saved topology" view. The failed device is displayed with red bordered device head and red wrench

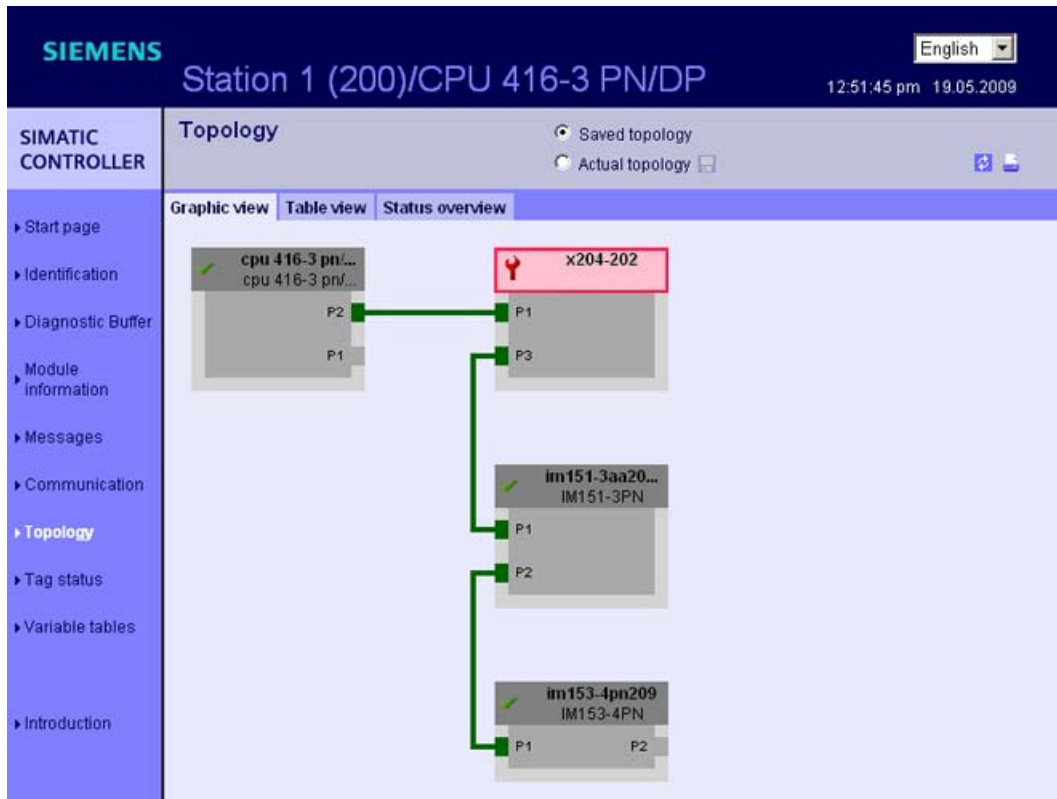

Figure 4-22 "Saved topology" with failed device

"Saved topology" of a failed, non-configured, direct neighbor PROFINET device.

If a saved, non-configured, direct neighbor PROFINET device has failed, this device remains in the same place in the "Saved topology" view. The failed device is displayed with red dashed device head.

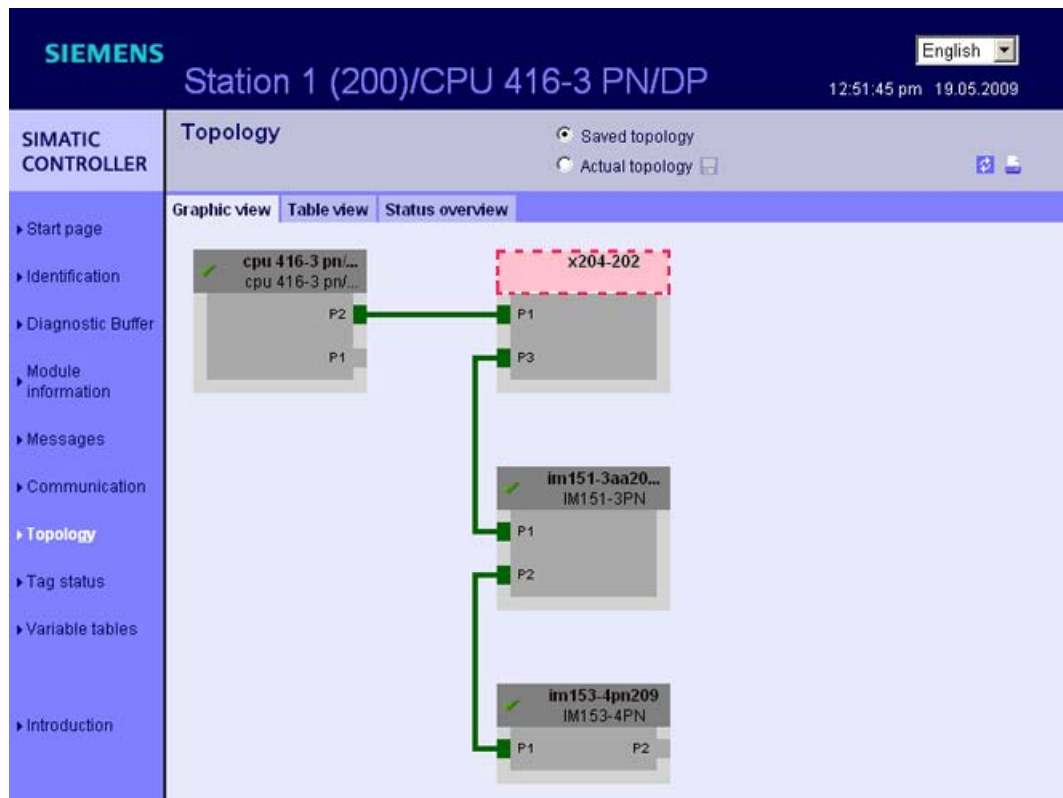

Figure 4-23 "Saved topology" of a failed, non-configured device.

"Actual topology" with failed device

Now switch to "Actual topology". In this view the device that has since failed is shown separately in the bottom area of the view. The failed device is displayed with red bordered device head and red wrench.

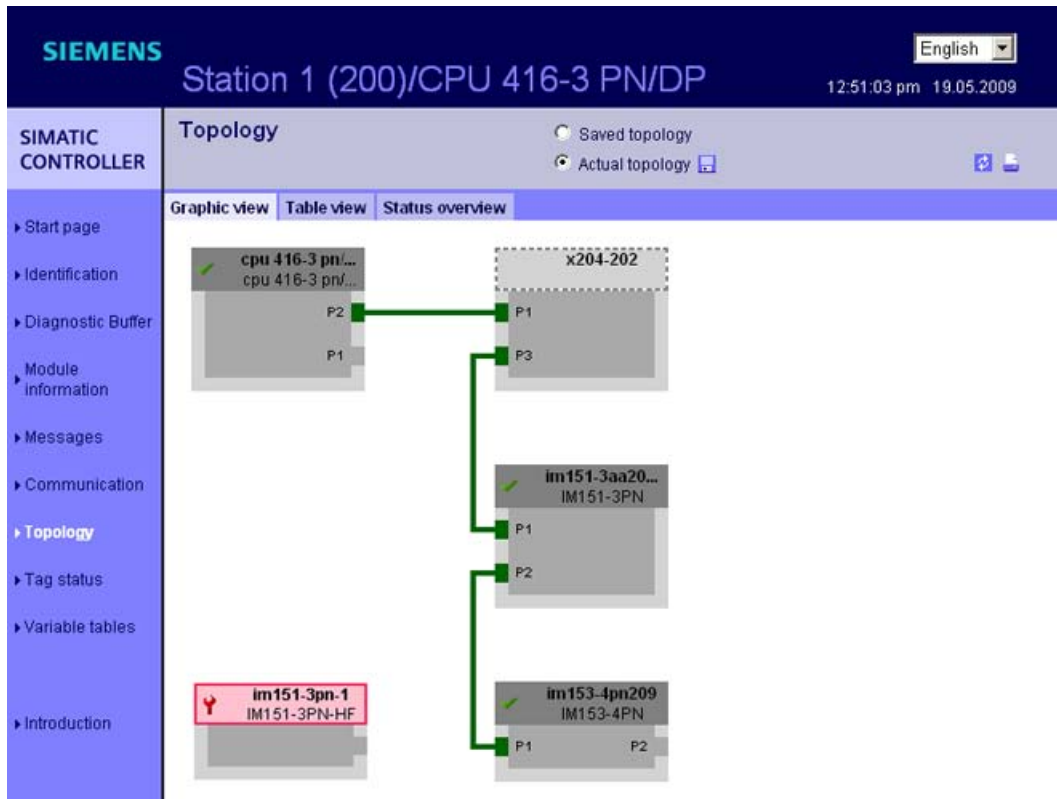

Figure 4-24 "Actual topology" with failed device

4.7.5.9 Variable status

Variable status

The browser outputs the variable status on the Web page of the same name. You can monitor the status of up to 50 variables.

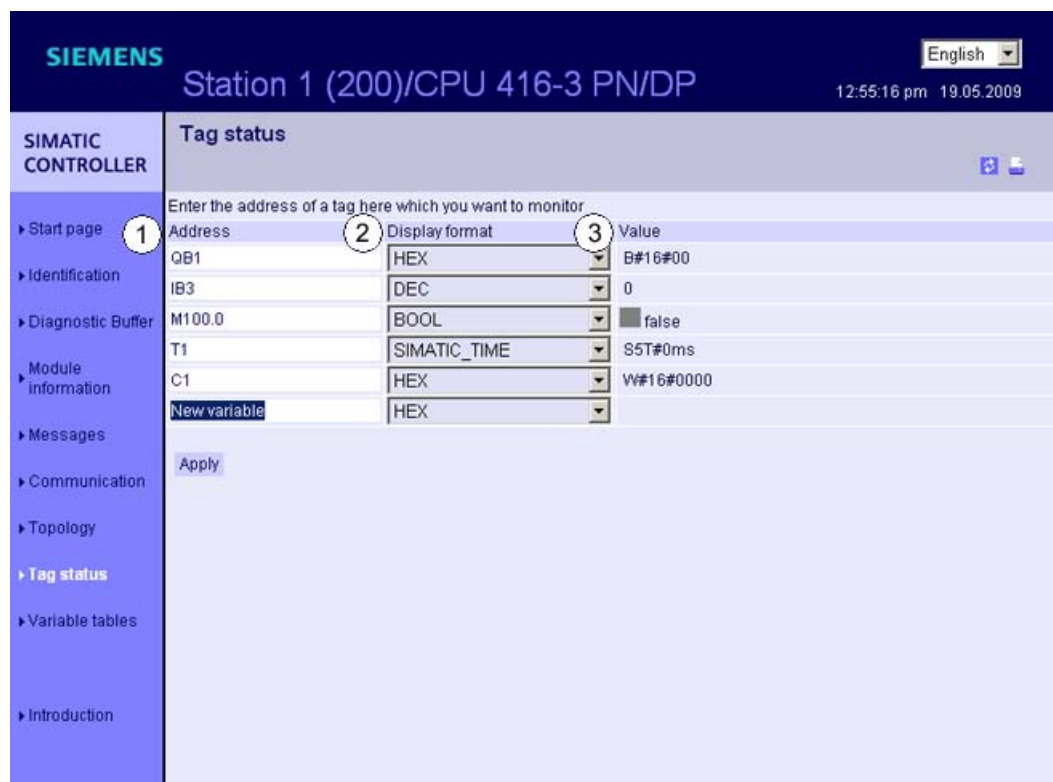

Figure 4-25 Variable status

① Address

Enter the address of the operand of which you want to monitor the response in the "Address" text box. Invalid addresses entered are displayed in red font.

To retain these entries, save the variable status Web page in the Favorites list of your browser.

② Display format

Select the display format of a variable using the drop-down list. The program indicates the variable in hex code if it does not support the selected display format.

③ Value

Outputs the value of the corresponding operand in the selected format.

Special features when changing languages

You can change the language, for example, from German to English, by clicking the object in the upper right corner. The German mnemonics differ compared to other languages. The syntax of operands you enter may be invalid for this reason when you change languages. For example, ABxy instead of QBxy. The browser outputs a faulty syntax in red font.

4.7.5.10 Variable tables

Variable tables

The browser displays the content of the variable tables on the Web page of the same name. You can monitor up to 50 variable tables with a of maximum 200 variables.

Name	Address	Format	Value	Comment
	MB 22	BIN	2#0000_0000	
	MB 23	BIN	2#0000_0000	
	MB 20	BIN	2#0000_0000	
	DB91.DBD 0	DEC	L#16777217	
"urcv1".R_ID	DB91.DBD 4	DEC	L#129	
	DB91.DBD 36	DEC	L#0	
	DB91.DBD 1	DEC	L#23233536	
"urcv1".STATUS	DB91.DBW 10	DEC	1	
"urcv1".STATUS	DB91.DBW 10	HEX	W#16#0001	
	DB91.DBW 32	DEC	4096	
	DB91.DBW 34	HEX	W#16#0000	
T 98		SIMATIC_TIME	S5T#0ms	
T 99		SIMATIC_TIME	S5T#0ms	
	DB99.DBW 0	HEX	W#16#0000	
	QW 0	HEX	W#16#0000	
	QW 2	HEX	W#16#0000	

Figure 4-26 Variable tables

① Selection

Select one of the configured variable tables from this drop-down list.

② Name and address

This field displays the operand's name and address.

③ Format

Select the display format of the corresponding operand using the drop-down lists. The drop-down list outputs a selection of all valid display formats.

④ Value

This column shows the values in the corresponding display format.

⑤ Comment

The program outputs the comment you configured in order to highlight the meaning of an operand.

Creating a variable table for the Web server

1. Generate a variable table in STEP 7.
2. Open the properties dialog of the variable table and select the "General - Part 2" tab.
3. Activate the "Web server" check box. As an alternative, you can enter the ID "VATtoWEB" in the "Family" field.

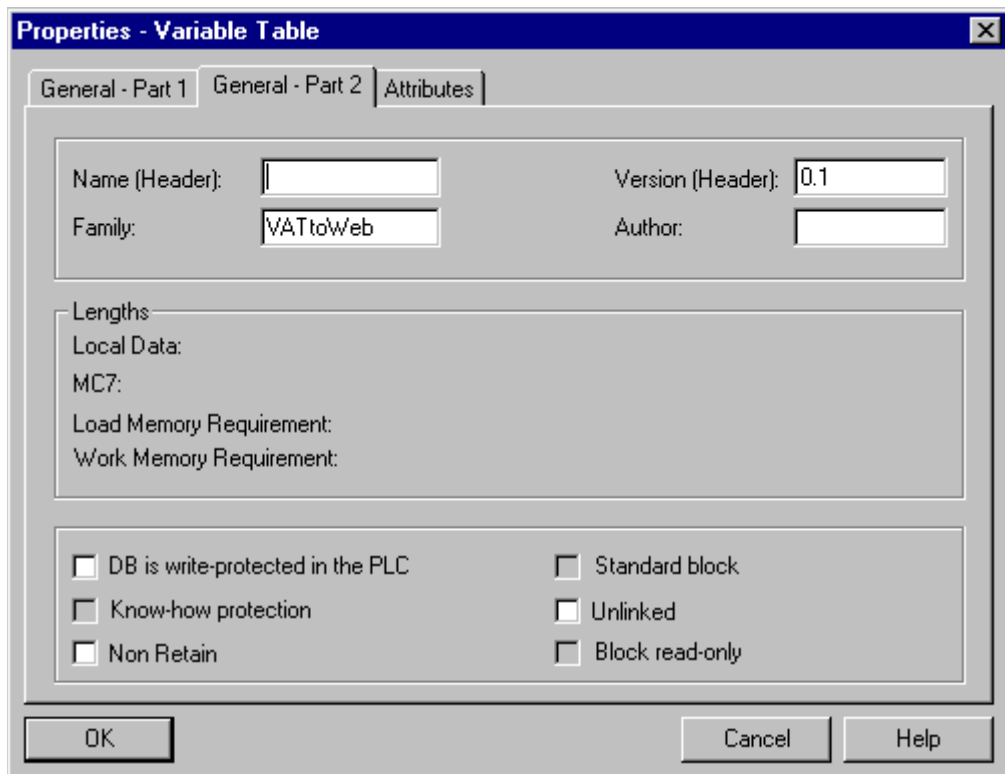

4. Save and compile the project and download the configuration data to the CPU.

PROFIBUS DP

5.1 CPU 41x as DP master / DP slave

5.1.1 Overview

Introduction

This section describes the properties and technical specifications that you will need when you use a CPU 41x as a DP master or DP slave and configure it for direct data exchange.

Declaration: The DP master / DP slave behavior is the same for all CPUs therefore the CPUs described below will be named CPU 41x.

Further Information

For information on the hardware and software configuration of a PROFIBUS subnet and on diagnostic functions within the PROFIBUS subnet, refer to the STEP 7 Online Help.

5.1.2 DP address areas of 41x CPUs

Address Areas of 41x CPUs

Table 5- 1 41x CPUs (MPI/DP interface as PROFIBUS DP)

Address area	412-1	412-2	414-2	416-2
MPI interface as PROFIBUS DP, both inputs and outputs (bytes)	2048	2048	2048	2048
DP interface as PROFIBUS DP, both inputs and outputs (bytes)	-	4096	6144	8192

Table 5- 2 41x CPUs (MPI/DP interface and DP module as PROFIBUS DP)

Address area	414-3	416-3	417-4
MPI interface as PROFIBUS DP, both inputs and outputs (bytes)	2048	2048	2048
DP interface as PROFIBUS DP, both inputs and outputs (bytes)	6144	8192	8192
DP module as PROFIBUS DP, both inputs and outputs (bytes)	6144	8192	8192

You can add all inputs and outputs to the process image of the CPU.

DP diagnostics addresses

In the input address area, the DP diagnostic addresses occupy at least 1 byte for the DP master and each DP slave. The DP standard diagnostics for each node can be called at these addresses, for example (LADDR parameter of SFC13). You specify the DP diagnostic addresses during project engineering. If you do not specify DP diagnostic addresses, STEP 7 assigns the addresses as DP diagnostic addresses in descending order starting at the highest byte address.

In the DPV1 master mode, the slaves are usually assigned two diagnostic addresses.

5.1.3 CPU 41x as PROFIBUS DP master

Introduction

This section describes the properties and technical specifications of the CPU if you operate it as a PROFIBUS DP master.

Reference

You can find the features and technical specifications of the 41x CPUs as of in this manual in *Technical specifications*.

Requirements

You will need to configure the relevant CPU interface for use as a DP master. This means that you do the following in *STEP 7*:

1. Configure the CPU as a DP master
2. Assign a PROFIBUS address.
3. Select an operating mode (S7-compatible or DPV1).
4. Assign a diagnostics address.
5. Connect DP slaves to the DP master system.

Note

Is one of the PROFIBUS DP slaves a CPU 31x or CPU 41x?

If yes, you will find it in the PROFIBUS DP catalog as a "preconfigured station". Assign this DP slave CPU a slave diagnostics address in the DP master. Interconnect the DP master with the DP slave CPU, and define the address areas for data exchange with the DP slave CPU.

From EN 50170 to DPV1

The standard concerning distributed I/O (EN 50170) has been further developed. The results were incorporated into IEC 61158 / IEC 61784-1:2002 Ed1 CP 3/1. The SIMATIC documentation refers to this as DPV1.

Operating modes for DPV1 components

- S7-compatible mode

In this mode, the components are compatible with EN 50170. Note that you cannot utilize the full DPV1 functionality in this mode.

- DPV1 mode

In this mode, you can utilize the full DPV1 functionality. Automation components in the station that do not support DPV1 can be used as before.

DPV1 and EN 50170 compatibility

You can continue to use all existing slaves after the system conversion to DPV1. These do not, however, support the enhanced function of DPV1.

DPV1 slaves can be used in systems that are not converted to DPV1. In this case, their behavior corresponds with that of conventional slaves. SIEMENS DPV1 slaves can be operated in S7-compatible mode. For the DPV1 slaves of other manufacturers, you need a GSD file < Rev. 3 file to EN 50170.

Additional information

A comprehensive description of migration from EN 50170 to DPV1 is provided in the FAQ titled Migration from EN 50170 to DPV1

(<http://support.automation.siemens.com/WW/view/en/7027576>)

Status/modify, programming via PROFIBUS

As an alternative to the MPI interface, you can use the PROFIBUS DP interface to program the CPU or execute the programming device functions Monitor and Modify.

Note

The execution of programming and status and modify functions via PROFIBUS DP interface prolongs the DP cycle.

Constant bus cycle time

This is a property of PROFIBUS DP that ensures same length bus cycles. The "Constant bus cycle time" function ensures that the DP master always starts the DP bus cycle within a constant interval. From the perspective of the slaves, this means that they receive their data from the master at constant time intervals.

The constant cycle time (isochronous) PROFIBUS is the basis for "isochronous mode".

Isochronous mode

S7-400 CPUs support the mechanism of isochronous reading and outputting of I/O signals. This allows the user program to synchronize with the I/O processing. Input data is then recorded at a set time and output data takes effect at a set time.

Full "terminal-to-terminal" support of isochronous mode is only possible if all components within the sequence support the "isochronous mode" system property.

The *Isochronous mode* manual contains a full overview of this system property.

Isochronous updating of process image partitions

SFC126 "SYNC_PI" is used to isochronously update a process input image partition. A user program which is linked to a DP cycle can use the SFC to update the input data in the process input image partition consistently and synchronously with these intervals. SFC126 accepts interrupt control and can only be called in OBs 61, 62, 63 and 64.

SFC 127 "SYNC_PO" is used to isochronously update the process output image partition. An application program which is linked to a DP cycle can use the SFC to transfer the computed output data from a process output image partition to the I/O consistently and synchronously with these intervals. SFC127 accepts interrupt control and can only be called in OBs 61, 62, 63 and 64.

To allow isochronous updates of process image partitions, all input or output addresses of a slave must be assigned to the same process image partition.

To ensure consistency of data in a process image partition, the following conditions must be satisfied on the various CPUs:

- CPU 412: Number of slaves + number of bytes / 100 < 16
- CPU 414: Number of slaves + number of bytes / 100 < 26
- CPU 416: Number of slaves + number of bytes / 100 < 40
- CPU 417: Number of slaves + number of bytes / 100 < 44

SFCs 126 and 127 are described in the corresponding Online Help and in the *System and Standard Functions* manual.

Consistent user data

Data that belongs together in terms of its content and describes a process state at a specific point in time is known as consistent data. To maintain consistency, the data should not be changed or updated during processing or transmission.

For a description, please refer to the section Consistent Data (Page 179).

Sync/Freeze

The SYNC control command is used to set sync mode on the DP slaves of selected groups. In other words, the DP master transfers current output data and instructs the relevant DP slaves to freeze their outputs. The DP slaves write the output data of the next output frames to an internal buffer; the state of the outputs remains unchanged.

Following each SYNC control command, the DP slaves of the selected groups transfer the output data stored in the internal buffer to the process outputs.

The outputs are only updated cyclically again after you transfer the UNSYNC control command using SFC11 "DPSYC_FR".

The FREEZE control command is used to set the relevant DP slaves to Freeze mode, in other words, the DP master instructs the DP slaves to freeze the current state of the inputs. It then transfers the frozen data to the input area of the CPU.

Following each FREEZE control command, the DP slaves freeze the state of their inputs again.

The DP master receives the current state of the inputs cyclically, again not until you have sent the UNFREEZE control command with SFC11 "DPSYC_FR".

For information on SFC11, refer to the corresponding online help and to the *System and Standard Functions* manual

Startup of the DP master system

Use the following parameters to set startup monitoring of the DP master:

- Transfer of the parameters to modules
- "Ready" message from the module

That is, the DP slaves must start up within the set time and be configured by the CPU (as DP master).

PROFIBUS address of the DP master

All PROFIBUS addresses are allowed.

See also

System and Standard Functions

(<http://support.automation.siemens.com/WW/view/en/1214574>)

Isochrone mode (<http://support.automation.siemens.com/WW/view/en/15218045>)

5.1.4 Diagnostics of the CPU 41x as DP master

Diagnostics using LEDs

The following table explains the meaning of the BUSF LED. The BUSF LED assigned to the interface configured as the PROFIBUS DP interface will always light up or flash.

Table 5- 3 Meaning of the "BUSF" LED of the CPU 41x as DP master

BUSF	Meaning	Remedy
Off	Configuration correct; All configured slaves can be addressed	–
Lit	<ul style="list-style-type: none"> Bus fault (hardware fault) DP interface fault Different transmission rates in multi-DP master mode 	<ul style="list-style-type: none"> Check for short-circuit or interruption of the bus cable. Evaluate the diagnostics. Reconfigure or correct the configuration.
Flashing	<ul style="list-style-type: none"> Station failure At least one of the assigned slaves cannot be addressed 	<ul style="list-style-type: none"> Check whether all the configured nodes are correctly connected to the bus. Wait until the CPU 41x has started up. If the LED does not stop flashing, check the DP slaves or analyze the diagnostic data of the DP slaves.
flashes briefly INTF lights up briefly	CiR synchronization running	–

Triggering Detection of the Bus Topology in a DP Master System with the SFC103 "DP_TOPOL"

The diagnostic repeater is available to improve the ability to locate faulty modules or an interruption on the DP cable when failures occur in ongoing operation. This module operates as a slave and can identify the topology of a DP chain and record any faults originating from it.

You can use SFC103 "DP_TOPOL" to trigger the identification of the bus topology of a DP master system by the diagnostic repeater. For information on SFC103, refer to the corresponding Online Help and to the *System and Standard Functions* manual. The diagnostic repeater is described in the manual *Diagnostic Repeater for PROFIBUS DP*, order number 6ES7972-0AB00-8BA0.

Reading the Diagnostic Data with **STEP 7**

Table 5- 4 Reading the diagnostic data with STEP 7

DP master	Block or tab in STEP 7	Application	Reference
CPU 41x	"DP Slave Diagnostics" tab	Show slave diagnostics in clear text on the STEP 7 user interface	See the section on hardware diagnostics in the STEP 7 Online Help and in the <i>Programming with STEP 7</i> manual
	SFC 13 "DPNRM_DG"	Read slave diagnostics (save to data area of the user program)	SFC, see <i>System Software for S7-300/400, System and Standard Functions</i> reference manual. For the structure of other slaves, refer to their descriptions.
	SFC59 "RD_REC"	Reading the data records of S7 diagnostics (stored in the data area of the user program)	<i>System Software for S7-300/400, System and Standard Functions</i> reference manual.
	SFC 51 "RDSYSST"	Reading partial SSL lists. Call SFC51 in the diagnostic interrupt using the SSL ID W#16#00B3 and read out the SSL of the slave CPU.	
	SFB 52 "RDREC"	Reading the data records of S7 diagnostics (stored in the data area of the user program)	
	SFB 54 "RALRM"	To read out interrupt information within the associated interrupt OB	
	SFC 103 "DP_TOPOL"	Triggers detection of the bus topology of a DP master system with diagnostic repeaters installed there.	

Analysis of Diagnostic Data in the User Program

The following figure shows you how to evaluate the diagnostic data in the user program.

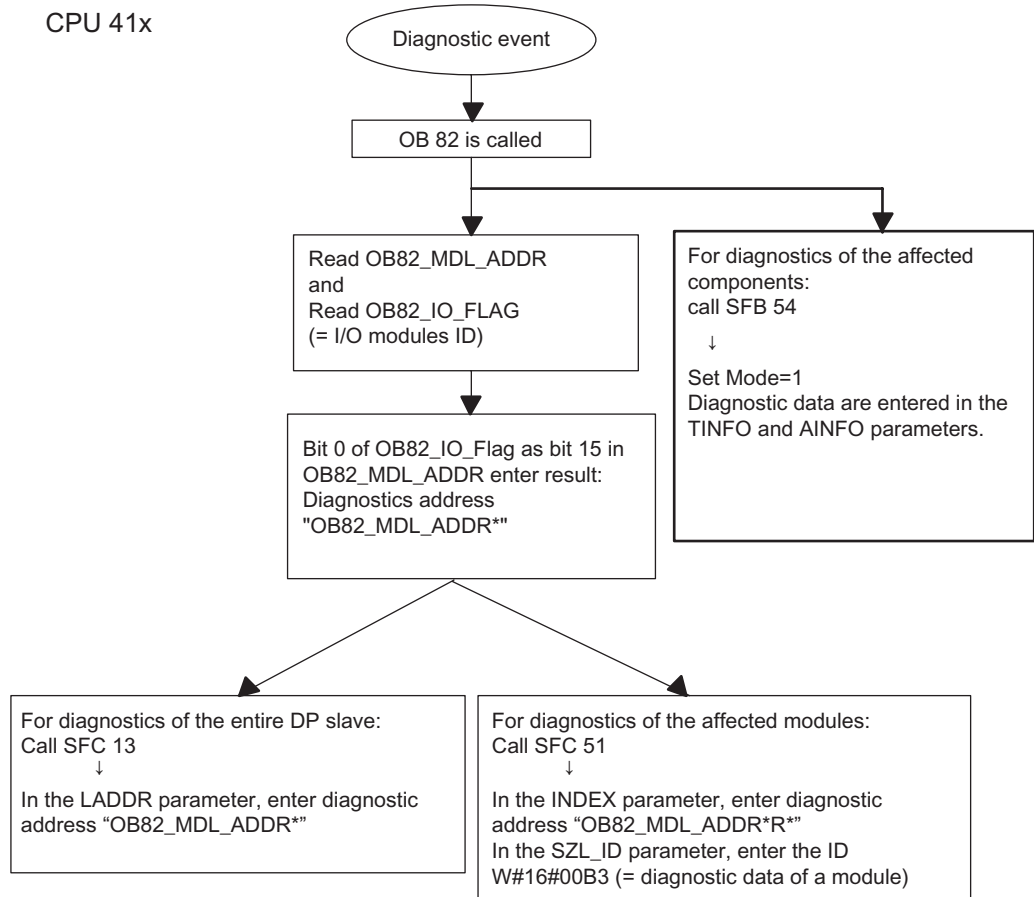

Figure 5-1 Diagnostics with CPU 41x

Diagnostic Addresses in Connection with DP Slave Functionality

You assign diagnostic addresses for the PROFIBUS DP in the CPU 41x. Verify in your configuration that the DP diagnostic addresses are assigned once to the DP master and once to the DP slave.

Table 5- 5 Diagnostic addresses for the DP master and DP slave

S7 CPU as DP master	S7 CPU as DP slave
<p>During configuration of the DP master, specify (in the associated project of the DP master) a diagnostic address for the DP slave. This diagnostic address is identified as <i>assigned to DP master</i> below.</p> <p>The DP master uses this diagnostic address to receive information about the status of the DP slave or a bus interruption (see also table "Event detection of the CPUs 41x as DP master").</p>	<p>During configuration of the DP slave, also specify (in the associated project of the DP slave) a diagnostic address that is <i>assigned to the DP slave</i>. This diagnostic address is identified as assigned to the DP slave below.</p> <p>The DP master uses this diagnostic address to receive information about the status of the DP master or a bus interruption (see also table "Event detection of the CPUs 41x as DP slave").</p>

Event Detection

The following table shows you how the CPU 41x as DP master detects any changes in the operating mode of a CPU as DP slave or interruptions in data transfer.

Table 5- 6 Event detection of the CPUs 41x as DP master

Event	What happens in the DP master
Bus interruption (short-circuit, connector removed)	<ul style="list-style-type: none"> • OB86 called with the message station failure (event entering state; diagnostic address of the DP slave that is assigned to the DP master) • With I/O access: call of OB 122 (I/O access error)
DP slave: RUN → STOP	<ul style="list-style-type: none"> • OB82 is called with the message "Faulty module" (event entering state; diagnostic address of the DP slave that is assigned to the DP master; tag OB82_MDL_STOP=1)
DP slave: STOP → RUN	<ul style="list-style-type: none"> • OB82 is called with the message "Module OK" (event exiting state; diagnostic address of the DP slave that is assigned to the DP master; tag OB82_MDL_STOP=0)

Evaluation in the User Program

The following table shows you how, for example, you can evaluate RUN-STOP transitions of the DP slave in the DP master (see also table "Event detection of the CPUs 41x as DP master").

Table 5- 7 Evaluation of RUN-STOP transitions of the DP slave in the DP master

In the DP master		In the DP slave (CPU 41x)
Diagnostic addresses: (example) Master diagnostic address= 1023 Slave diagnostic address in the master system= 1022		Diagnostic addresses: (example) Slave diagnostic address= 422 Master diagnostic address=not relevant
<p>The CPU calls OB82 with at least the following information:</p> <ul style="list-style-type: none"> • OB82_MDL_ADDR:=1022 • OB82_EV_CLASS:=B#16#39 (incoming event) • OB82_MDL_DEFECT:=module fault <p>Tip: The CPU diagnostic buffer also contains this information</p> <p>You should also program the SFC "DPNRM_DG" in the user program to read out the DP slave diagnostic data.</p> <p>Use SFB54. It outputs the interrupt information in its entirety.</p>	←	<p>CPU: RUN → STOP</p> <p>CPU generates a DP slave diagnostic frame.</p>

5.1.5 CPU 41x as DP slave

Introduction

This section describes the properties and technical specifications of the CPU if you use it as a DP slave.

Reference

You can find the features and technical specifications of the 41x CPUs in the section *Technical Specifications*.

Requirements

- Only one DP interface of a CPU can be configured as a DP slave.
- Will the MPI/DP interface be a DP interface? If so, you must configure the interface as a DP interface.

Before commissioning you must configure the CPU as a DP slave. In other words, you must do the following in STEP 7

- Activate the CPU as a DP slave,
- Assign a PROFIBUS address,
- Assign a slave diagnostics address
- Define the address areas for data transfer to the DP master

Configuration and parameterization frame

When you configure and assign parameters to CPU 41x, you are supported by *STEP 7*. A description of the configuration and parameterization frame (<http://support.automation.siemens.com/WW/view/en/1452338>) you might need, for example, to use a bus monitoring function is available on the Internet.

Monitor/Modify and Programming via PROFIBUS

As an alternative to the MPI interface, you can use the PROFIBUS DP interface to program the CPU or execute the programming device functions Monitor and Modify. To do this, you must enable these functions when you configure the CPU as DP slave in *STEP 7*.

Note

The use of Programming or Monitor and Modify via the PROFIBUS DP interface extends the DP cycle.

Data Transfer Via a Transfer Memory

As a DP slave the CPU 41x makes a transfer memory available to PROFIBUS DP. Data transfer between the CPU as DP slave and the DP master always takes place via this transfer memory. Configure the following address areas: Maximum of 244 bytes per input and 244 bytes per output with a maximum of 32 bytes per module.

That is, the DP master writes its data to these transfer memory address areas, the CPU reads these data in the user program, and vice versa.

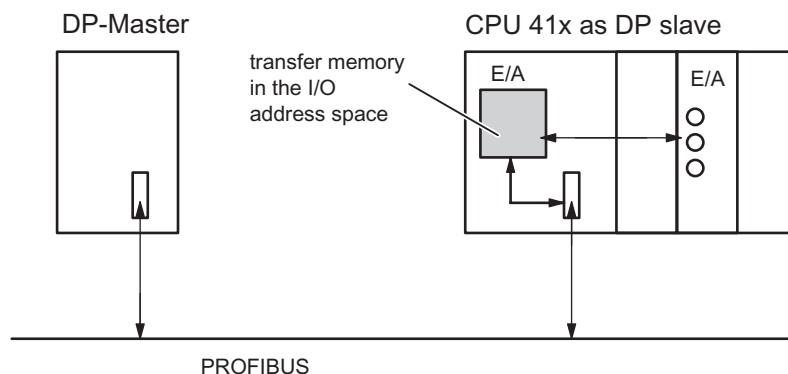

Figure 5-2 Transfer memory in the CPU 41x as DP slave

Address Areas of the Transfer Memory

Configure the input and output address areas in *STEP 7*:

- You can configure up to 32 input and output address areas.
- Each of these address areas can be up to 32 bytes in size.
- You can configure a maximum of 244 bytes of inputs and 244 bytes of outputs in total.

An example for the configuration of the address assignments of the transfer memory is provided in the table below. You will also find this in the online help for STEP 7 configuration.

Table 5- 8 Configuration example for the address areas of the transfer memory

	Type	Master address	Type	Slave address	Length	Unit	Consistency
1	I	222	O	310	2	Byte	Unit
2	O	0	I	13	10	Word	Total length
:							
32							
		Address areas in the DP master CPU		Address areas in the DP slave CPU		These parameters of the address areas must be the same for the DP master and DP slave	

Rules

You must adhere to the following rules when working with the transfer memory:

- Assignment of the address areas:
 - Input data for the DP slave is **always** output data from the DP master
 - Output data from the DP slave is **always** input data for the DP master
- You can assign the addresses as you choose. You access the data in the user program with load/transfer commands or with SFCs 14 and 15. You can also specify addresses from the process image input and output table (see also section "DP address areas of the 41x CPUs").

Note

You assign addresses for the transfer memory from the DP address area of the CPU 41x.

You must not reassign the addresses you have already assigned to the transfer memory to the I/O modules on the CPU 41x.

- The lowest address in each address area is the start address of that address area.
- The length, unit and consistency of address areas for the DP master and DP slave that belong together must be the same.

S5 DP Master

If you use an IM 308 C as a DP master and the CPU 41x as a DP slave, the following applies to the exchange of consistent data:

You must program FB192 in the IM 308-C so that consistent data can be transferred between the DP master and DP slave. The data of the CPU 41x is only output or displayed contiguously in a block with FB192.

AG S5-95 as a DP Master

If you use an AG S5-95 as a DP master, you must also set its bus parameters for the CPU 41x as DP slave.

Sample Program

The small sample program below illustrates data transfer between the DP master and DP slave. This example contains the addresses from the table "Configuration example for the address areas of the transfer memory".

In the DP slave CPU				In the DP master CPU			
L	2		Data preprocessing in the DP slave				
M	MB	6					
L	IB	0					
M	MB	7					
L	MW	6	Transfer data to the DP master				
M	PQW	310					
				L	PIB	222	Process received data in the DP master
				M	MB	50	
				L	PIB	223	
				L	B#16#3		
				+	I		
				M	MB	51	
				L	10		Data preprocessing in the DP master
				+	3		
				M	MB	60	
				CALL	SFC	15	Send data to the DP slave
					LADDR:= W#16#0		
					RECORD:= P#M60.0 Byte20		
					RET_VAL:= MW 22		
CALL	SFC	14	Receive data from the DP master				
					LADDR:=W#16#D		
					RET_VAL:=MW 20		
					RECORD:=P#M30.0 Byte20		
L	MB	30	Process received data				
L	MB	7					
+	I						
M	MW	100					

Data Transfer in STOP Mode

The DP slave CPU changes to STOP mode: The output data of the slave in the transfer memory of the CPU is overwritten with "0". In other words, the DP master reads "0". The input data of the slave is retained.

The DP master changes to STOP mode: The current data in the transfer memory of the CPU is retained and can continue to be read by the CPU.

PROFIBUS address

You must not set 126 as the PROFIBUS address for the CPU 41x as DP slave.

5.1.6 Diagnostics of the CPU 41x as DP slave

Diagnostics with LEDs – CPU 41x

The following table explains the meaning of the BUSF LEDs. The BUSF LED assigned to the interface configured as the PROFIBUS DP interface is always lit or flashing.

Table 5- 9 Meaning of the "BUSF" LEDs of the CPU 41x as DP slave

BUSF	Meaning	Remedy
Off	Configuration correct	–
Flashing	<p>The parameter settings of the CPU 41x are incorrect. There is no data exchange between the DP master and the CPU 41x.</p> <p>Causes:</p> <ul style="list-style-type: none"> • The response monitoring timeout. • Bus communication over PROFIBUS DP was interrupted. • The PROFIBUS address is incorrect. 	<ul style="list-style-type: none"> • Check the CPU 41x. • Check to make sure that the bus connector is properly inserted. • Check whether the bus cable to the DP master has been disconnected. • Check the configuration and parameter settings.
on	<ul style="list-style-type: none"> • Bus short-circuit 	<ul style="list-style-type: none"> • Check the bus configuration

Determining the bus topology in a DP master system with the SFC 103 "DP_TOPOL"

The diagnostics repeater is available to improve the ability to locate faulty modules or an interruption on the DP cable when failures occur in ongoing operation. This module operates as a slave and can identify the topology of a DP subnet and record any faults originating from it.

You can use SFC 103 "DP_TOPOL" to trigger the identification of the bus topology of a DP master system by the diagnostics repeater. For information on SFC 103, refer to the corresponding Online Help and to the *System and Standard Functions* manual. The diagnostics repeater is described in the *Diagnostics Repeater for PROFIBUS DP* manual, order number 6ES7972-0AB00-8BA0.

Diagnostics with STEP 5 or STEP 7 slave diagnostics

The slave diagnostics complies with the EN 50170, Volume 2, PROFIBUS standard. Depending on the DP master, diagnostics information can be read with STEP 5 or STEP 7 for all DP slaves that comply with the standard.

The display and structure of the slave diagnostics is described in the following sections.

S7 diagnostics

S7 diagnostics information can be requested in the user program from all modules with diagnostics functionality of the SIMATIC S7 product range. You can find out which modules support diagnostics in the module information or in the catalog. The structure of the S7 diagnostics data is the same for both central and distributed modules.

The diagnostics data of a module is located in data records 0 and 1 of the system data area of the module. Data record 0 contains 4 bytes of diagnostics data describing the current status of a module. Data record 1 also contains module-specific diagnostics data.

You will find the structure of the diagnostics data described in the System and Standard Functions (<http://support.automation.siemens.com/WW/view/en/1214574>) reference manual.

Reading the diagnostics

Table 5- 10 Reading the diagnostics data with STEP 5 and STEP 7 in the master system

Automation system with DP master	Block or tab in STEP 7	Application	Reference
SIMATIC S7	"DP Slave Diagnostics" tab	Show slave diagnostics in clear text on the STEP 7 user interface	See the section on hardware diagnostics in the STEP 7 Online Help and in the <i>Programming with STEP 7</i> manual
	SFC 13 "DP NRM_DG"	Read slave diagnostics (save to data area of the user program)	SFC, see <i>System Software for S7-300/400, System and Standard Functions</i> reference manual.
	SFC 51 "RDSYSST"	Read partial SSL lists. Call SFC 51 in the diagnostics interrupt using the SSL ID W#16#00B3 and read the SSL of the slave CPU.	<i>System Software for S7-300/400, System and Standard Functions</i> reference manual.
	SFB 54 "RDREC"	The following applies to the DPV1 environment: To read out interrupt information within the associated interrupt OB	
	FB125/FC125	Evaluating slave diagnostics data	On the Internet (http://support.automation.siemens.com/WW/view/en/387257)
SIMATIC S5 with IM 308-C as the DP master	FB 192 "IM308C"	Read slave diagnostics (save to data area of the user program)	For structure, see "Diagnostics of the CPU 41x as a DP slave" section; for the FBs see the <i>Distributed I/O Station ET 200</i> manual
SIMATIC S5 with the S5-95U programmable controller as the DP master	FB 230 "S_DIAG"		

Example of reading slave diagnostics data, using FB 192 "IM 308C"

Here you will find an example of how to use FB 192 to read the slave diagnostics for a DP slave in the STEP 5 user program.

Assumptions

For this STEP 5 user program, the following is assumed:

- The IM 308-C assigned as the DP master mode uses page frames 0 to 15 (number 0 of IM 308-C).
- The DP slave is assigned PROFIBUS address 3.
- Slave diagnostics data should be stored in DB 20. You can also use any other data block for this.
- The slave diagnostics data has a length of 26 bytes.

STEP 5 user program

Table 5- 11 STEP 5 user program

STL	Description		
:A	DB 30		Default address area for the IM 308-C
:SPA	FB 192		IM no. = 0, PROFIBUS address of the DP slave = 3
Name	:IM308C		Function: Read slave diagnostics
DPAD	:	KH F800	is not evaluated
IMST	:	KY 0, 3	S5 data area: DB 20
FCT	:	KC SD	Diagnostics data from data word 1
GCGR	:	KM 0	Length of diagnostics data = 26 bytes
TYPE		KY 0, 20	Error code storage in the DW 0 of the DB 30
STAD		KF +1	
LENG		KF 26	
ERR		DW 0	

Diagnostics addresses in connection with DP master functionality

You assign diagnostics addresses for the PROFIBUS DP in the CPU 41x. Verify in your configuration that the DP diagnostics addresses are assigned once to the DP master and once to the DP slave.

Table 5- 12 Diagnostics addresses for the DP master and DP slave

S7 CPU as DP master	S7 CPU as DP slave
<p>During configuration of the DP master, specify (in the associated project of the DP master) a diagnostics address for the DP slave. This diagnostics address is identified as assigned to the DP master below.</p> <p>The DP master uses this diagnostics address to receive information about the status of the DP slave or a bus interruption (see also table "Event detection of the CPUs 41x as DP master").</p>	<p>During configuration of the DP slave, also specify (in the associated project of the DP slave) a diagnostics address that is assigned to the DP slave. This diagnostics address is identified as assigned to the DP slave below.</p> <p>The DP master uses this diagnostics address to receive information about the status of the DP master or a bus interruption (see also table "Event detection of the CPUs 41x as DP slave").</p>

Event detection

The following table shows you how the CPU 41x as DP slave detects any operating mode changes or interruptions in data transfer.

Table 5- 13 Event detection of the CPUs 41x as DP slave

Event	What happens in the DP slave?
Bus interruption (short-circuit, connector removed)	<ul style="list-style-type: none"> • Calls OB 86 with the message <i>Station failure</i> (incoming event; diagnostics address of the DP slave, assigned to the DP slave) • With I/O access: call of OB 122 (I/O access error)
DP master RUN → STOP	<ul style="list-style-type: none"> • Call of OB 82 with the message <i>Module faulty</i>(incoming event; diagnostics address of the DP slave assigned to the DP slave; tag OB82_MDL_STOP=1)
DP master STOP → RUN	<ul style="list-style-type: none"> • OB 82 is called with the message <i>Module OK</i>(event exiting state; diagnostics address of the DP slave that is assigned to the DP slave; tag OB82_MDL_STOP=0)

Evaluation in the user program

The table below shows an example of you how you can evaluate RUN-STOP transitions of the DP master in the DP slave (see also the previous table).

Table 5- 14 Evaluating RUNSTOP transitions in the DP master/DP slave

In the DP master	In the DP slave (CPU 41x)
Diagnostics addresses: (example) Master diagnostics address= 1023 Slave diagnostics address in the master system= 1022	Diagnostics addresses: (example) Slave diagnostics address= 422 Master diagnostics address= not relevant
CPU: RUN → STOP	The CPU calls OB 82 with at least the following information: <ul style="list-style-type: none"> • OB82_MDL_ADDR:=422 • OB82_EV_CLASS:=B#16#39 (incoming event) • OB82_MDL_DEFECT:=module fault Tip: The CPU diagnostics buffer also contains this information

Example of the structure of slave diagnostics data

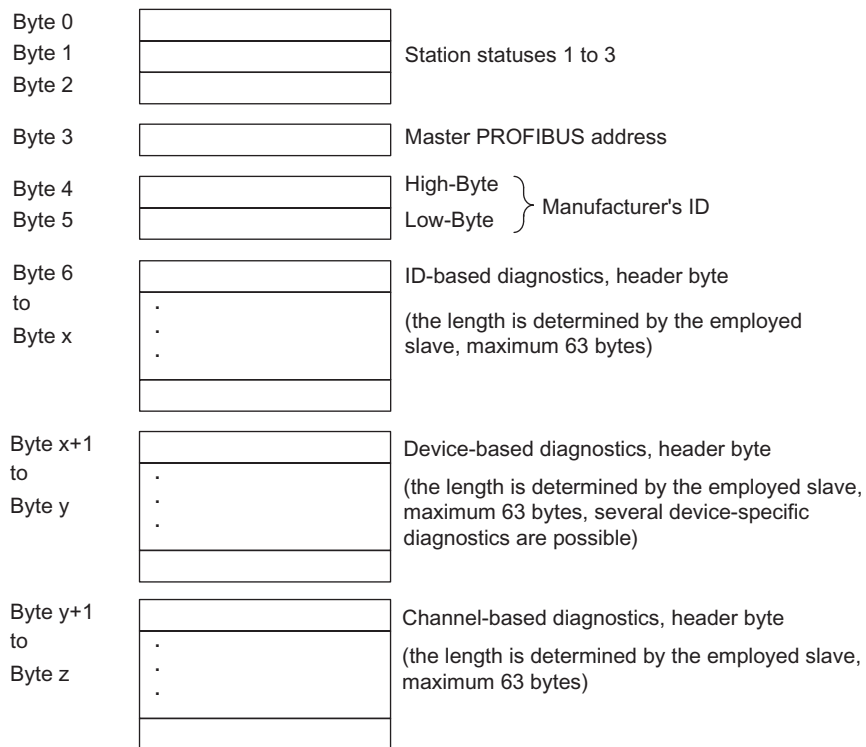

Figure 5-3 Structure of slave diagnostics

ID-based diagnostics, device-based diagnostics and channel-based diagnostics can be performed in any order for slave diagnostics.

5.1.7 CPU 41x as DP slave: Station statuses 1 to 3

Station status 1 to 3

Station status 1 to 3 provides an overview of the status of a DP slave.

Table 5- 15 Structure of station status 1 (Byte 0)

Bit	Meaning	Remedy
0	1:The DP slave cannot be addressed by the DP master.	<ul style="list-style-type: none"> • Correct DP address set on the DP slave? • Bus connector connected? • Voltage at DP slave? • RS-485 repeater set correctly? • Execute reset on the DP slave
1	1:The DP slave is not yet ready for data exchange.	<ul style="list-style-type: none"> • Wait while the DP slave powers up.
2	1:The configuration data sent by the DP master to the DP slave does not match the configuration of the DP slave.	<ul style="list-style-type: none"> • Correct station type or correct configuration of the DP slave entered in the software?
3	1:Diagnostic interrupt, triggered by RUN-STOP change on the CPU 0:Diagnostic interrupt, triggered by STOP-RUN change on the CPU	<ul style="list-style-type: none"> • You can read the diagnostic information.
4	1:Function is not supported, e.g. changing the DP address via software	<ul style="list-style-type: none"> • Check the configuration.
5	0:The bit is always "0".	–
6	1:The DP slave type does not correspond to the software configuration.	<ul style="list-style-type: none"> • Correct station type entered in the software? (Parameter assignment error)
7	1:Parameters have been assigned to the DP slave by a different DP master to the one that currently has access to the DP slave.	<ul style="list-style-type: none"> • The bit is always 1, for example, if you access the DP slave with the programming device or another DP master. The DP address of the parameter assignment master is in the "master PROFIBUS address" diagnostic byte.

Table 5- 16 Structure of station status 2 (Byte 1)

Bit	Meaning
0	1:The DP slave must be assigned new parameters and reconfigured.
1	1:There is a diagnostic message pending. The DP slave cannot continue until the problem has been eliminated (static diagnostic message).
2	1:The bit is always set to "1" if the DP slave with this DP address is present.
3	1:Watchdog monitoring is enabled for this DP slave.
4	0:The bit is always set to "0".
5	0:The bit is always set to "0".
6	0:The bit is always set to "0".
7	1:The DP slave is disabled; in other words, it has been removed from cyclic processing.

Table 5- 17 Structure of station status 3 (Byte 2)

Bit	Meaning
0 to 6	0: The bits are always set to "0".
7	1: <ul style="list-style-type: none"> • There are more diagnostic messages than the DP slave can store. • The DP master cannot enter all the diagnostic messages sent by the DP slave in its diagnostic buffer.

Master PROFIBUS Address

The master PROFIBUS address diagnostic byte contains the DP address of the DP master that:

- Assigned parameters to the DP slave and
- has read and write access to the DP slave

Table 5- 18 Structure of the master PROFIBUS address (byte 3)

Bit	Meaning
0 to 7	DP address of the DP master that configured the DP slave and that has read and write access to the DP slave.
	FFH: DP slave has not been assigned parameters by any DP master.

Identifier-related diagnostics

The ID-related diagnostic data tells you for which of the configured address areas of the transfer memory an entry has been made.

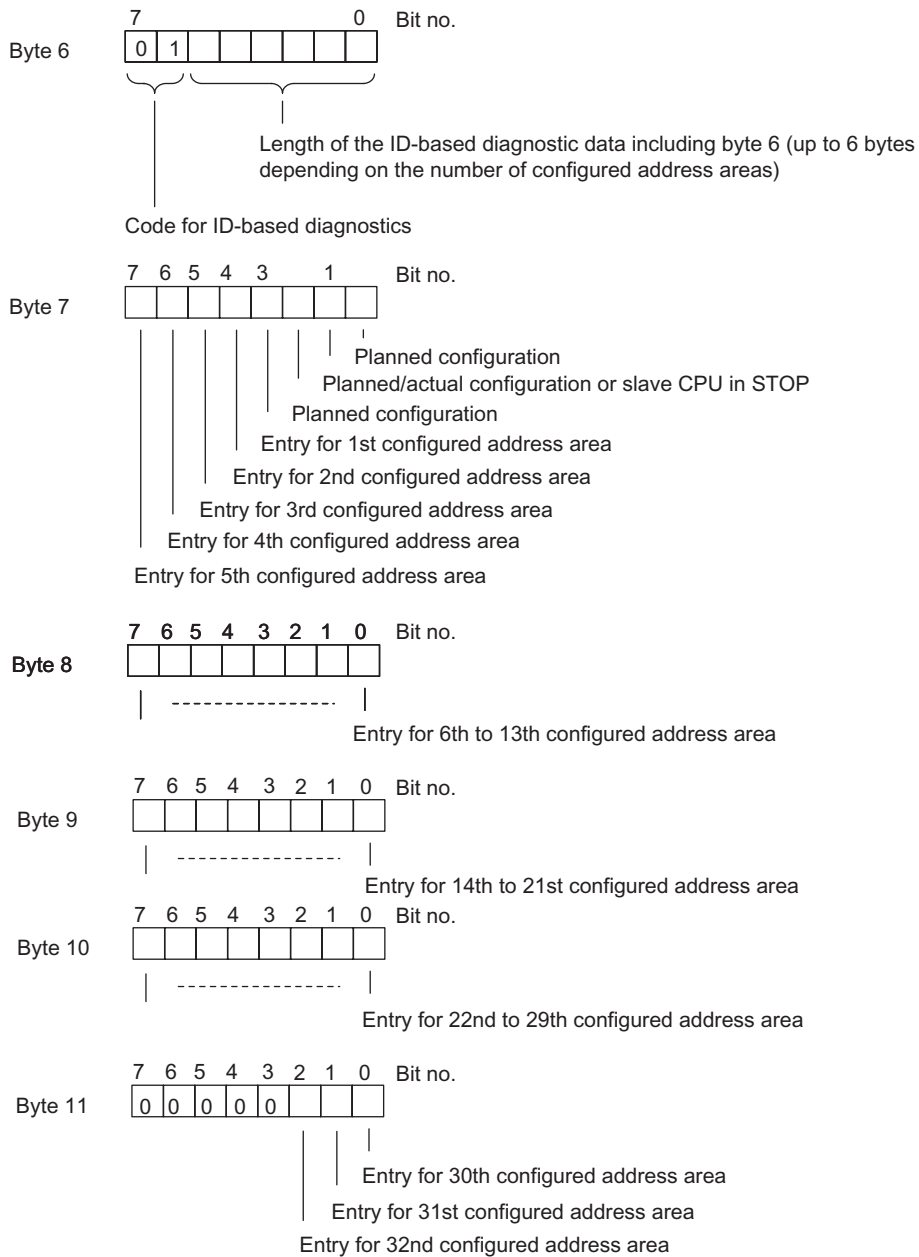

Figure 5-4 Structure of the ID-related diagnostic data of the CPU 41x

Device-Related Diagnostics

Device-related diagnostics provides detailed information about a DP slave. Device-related diagnostics starts at byte x and can include up to 20 bytes.

The figure below illustrates the structure and contents of the bytes for a configured address area of the transfer memory.

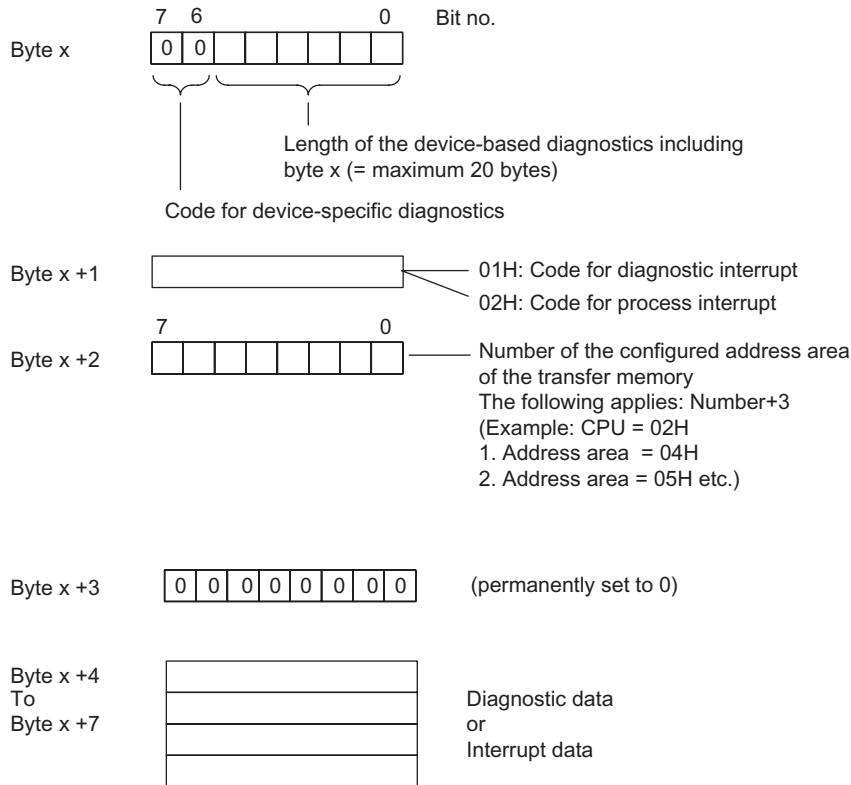

Figure 5-5 Structure of the device-related diagnostics

Starting at byte x + 4

The meaning of the bytes starting at byte x+4 depends on byte x + 1 (see figure "Structure of device-related diagnostics").

In byte x + 1, the code stands for...	
Diagnostic interrupt (01H)	Hardware interrupt (02H)
The diagnostic data contains the 16 bytes of status information of the CPU. The figure below shows the allocation of the first four bytes of diagnostic data. The following 12 bytes are always 0.	You can program 4 bytes of interrupt information any way you wish for the process interrupt. You transfer these 4 bytes to the DP master in <i>STEP 7</i> using SFC7 "DP_PRAL".

Bytes x +4 to x +7 for Diagnostic Interrupts

The following figure illustrates the structure and content of bytes x +4 to x +7 for the diagnostic interrupt. The data in these bytes correspond to the contents of data record 0 of the diagnostic data in STEP 7 (not all bits are used in this case).

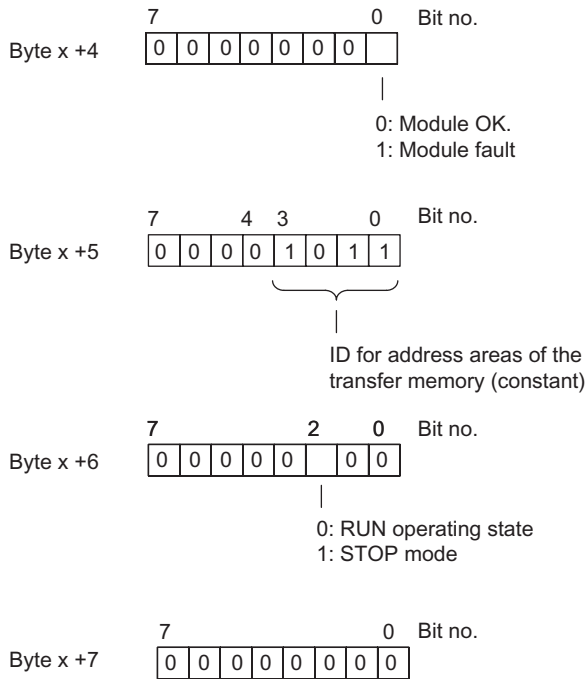

Figure 5-6 Bytes x +4 to x +7 for diagnostic and hardware interrupts

Interrupts with the S7 DP Master

In the CPU 41x as a DP slave you can trigger a process interrupt in the DP master from the user program. You can trigger an OB40 in the user program of the DP master by calling SFC7 "DP_PRAL". Using SFC7, you can forward interrupt information in a double word to the DP master and evaluate it in OB40 in the OB40_POINT_ADDR variable. You can program the interrupt information as required.. You will find a detailed description of SFC7 "DP_PRAL" in the *System Software for S7-300/400, System and Standard Functions* reference manual.

Interrupts with a Different DP Master

If you are using the CPU 41x with a different DP master, these interrupts are simulated in the device-related diagnostic data of the CPU 41x. You will have to process the relevant diagnostic events in the DP master's user program.

Note

Note the following in order to be able to evaluate diagnostic interrupts and hardware interrupts using device-related diagnostics when using a different DP master:

- the DP master should be able to save the diagnostic messages, i.e. the diagnostic messages should be stored within the DP master in a ring buffer. If there are more diagnostic messages than the DP master can store, then, for example, only the last diagnostic message received would be available for evaluation.
 - You must scan the relevant bits in the device-related diagnostic data in your user program at regular intervals. You must also take the PROFIBUS DP bus cycle time into consideration so that, for example, you can query the bits at least once synchronized with the bus cycle time.
 - With an IM 308-C operating in DP master mode, you cannot utilize process interrupts in device-specific diagnostics, because only incoming events are reported, rather than outgoing events.
-

5.1.8 Direct Data Exchange

5.1.8.1 Principle of direct data exchange

Overview

Direct data exchange is characterized by PROFIBUS DP nodes which "listen" on the bus and know which data a DP slave returns to its DP master.

This mechanism allows the "listening node" (recipient) direct access to deltas of input data of remote DP slaves.

In your STEP 7 configuration, define the address area of the recipient in which the required data of the publisher will be read, based on the peripheral input addresses.

A CPU 41x can be:

- Sender is a DP slave
- Recipient is a DP slave or DP master or a CPU that is not linked into a master system (see Fig. 3-9).

Example

The following figure uses an example to explain which direct data exchange "relations" you can configure. All the DP masters and DP slaves in the figure are 41x CPUs. Note that other DP slaves (ET 200M, ET 200X, ET 200S) can only be senders.

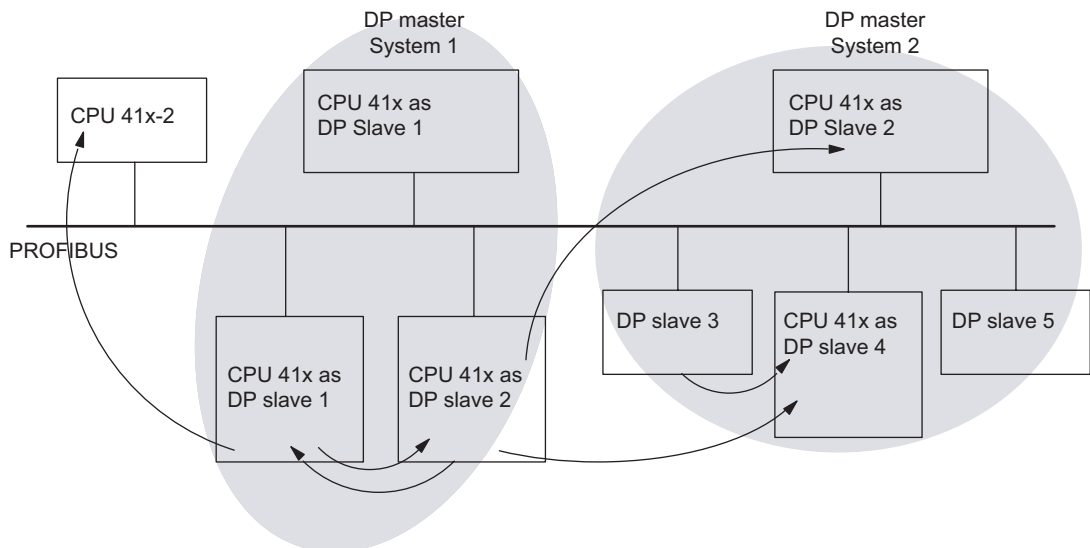

Figure 5-7 Direct data exchange with 41x CPUs

5.1.8.2 Diagnostics in direct data exchange

Diagnostic addresses

In direct data exchange you assign a diagnostic address in the recipient:

Table 5- 19 Diagnostic address for the recipient during direct data exchange

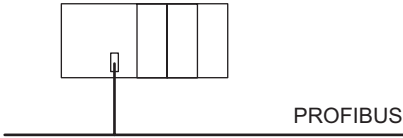
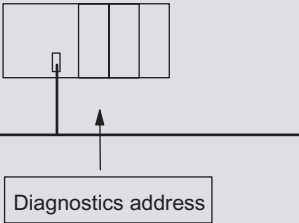
S7-CPU as sender	S7-CPU as recipient
 <p>The diagram shows a horizontal line representing the PROFIBUS bus. On the left side, a vertical line connects the bus to a box representing the S7-CPU as sender. This box contains five vertical bars, with the first one being taller than the others, indicating a specific diagnostic address.</p>	 <p>The diagram shows a horizontal line representing the PROFIBUS bus. On the right side, a vertical line connects the bus to a box representing the S7-CPU as recipient. This box contains five vertical bars, with the first one being taller than the others. Below this box is a separate box labeled 'Diagnostics address' with an arrow pointing up to the first bar of the recipient's box.</p>
	<p>During configuration you specify a diagnostic address in the recipient that is assigned to the sender. The recipient obtains information on the status of the sender or a bus interruption via this diagnostic address (see also following table).</p>

Event detection

The following table shows you how the CPU 41x as recipient detects interruptions in the data transfer.

Table 5- 20 Event detection by the 41x CPUs as recipients during direct communication

Event	What happens in the recipient
<p>Bus interruption (short-circuit, connector removed)</p>	<ul style="list-style-type: none"> • OB 86 is called with the station failure message (event entering state; diagnostic address of the recipient assigned to the sender) • With I/O access: call of OB 122 (I/O access error)

Evaluation in the user program

The following table shows you, for example, how you can evaluate a sender station failure in the recipient (see also table above).

Table 5- 21 Evaluation of the station failure in the sender during direct data exchange

In the sender		In the recipient
Diagnostic addresses: (example) Master diagnostic address= 1023 Slave diagnostic address in the master system= 1022		Diagnostic address: (example) Diagnostic address= 444
Station failure	→	The CPU calls OB 86 with at least the following information: <ul style="list-style-type: none"> • OB86_MDL_ADDR:=444 • OB86_EV_CLASS:=B#16#38 (event entering state) • OB86_FLT_ID:=B#16#C4 (failure of a DP station) Tip: The CPU diagnostic buffer also contains this information

5.1.9 Isochrone mode

Equidistant PROFIBUS

Equidistant (isochronous) PROFIBUS forms the basis for synchronized processing cycles. The PROFIBUS system provides a basic clock for this. The "isochrone mode" system property can couple a S7-400-CPU with the equidistant PROFIBUS.

Isynchronous data processing

Data is processed isochronously using the following method:

- Reading of the input data is synchronized with the DP cycle; all the input data is read at the same time.
- The user program that processes the data is synchronized with the DP cycle by means of the isochronous interrupt OBs OB61 to OB64.
- Data output is synchronized with the DP cycle; All the output data takes effect at the same time.
- All input and output data is transferred consistently. This means that all the data from the process image belongs together, both logically and with respect to timing.

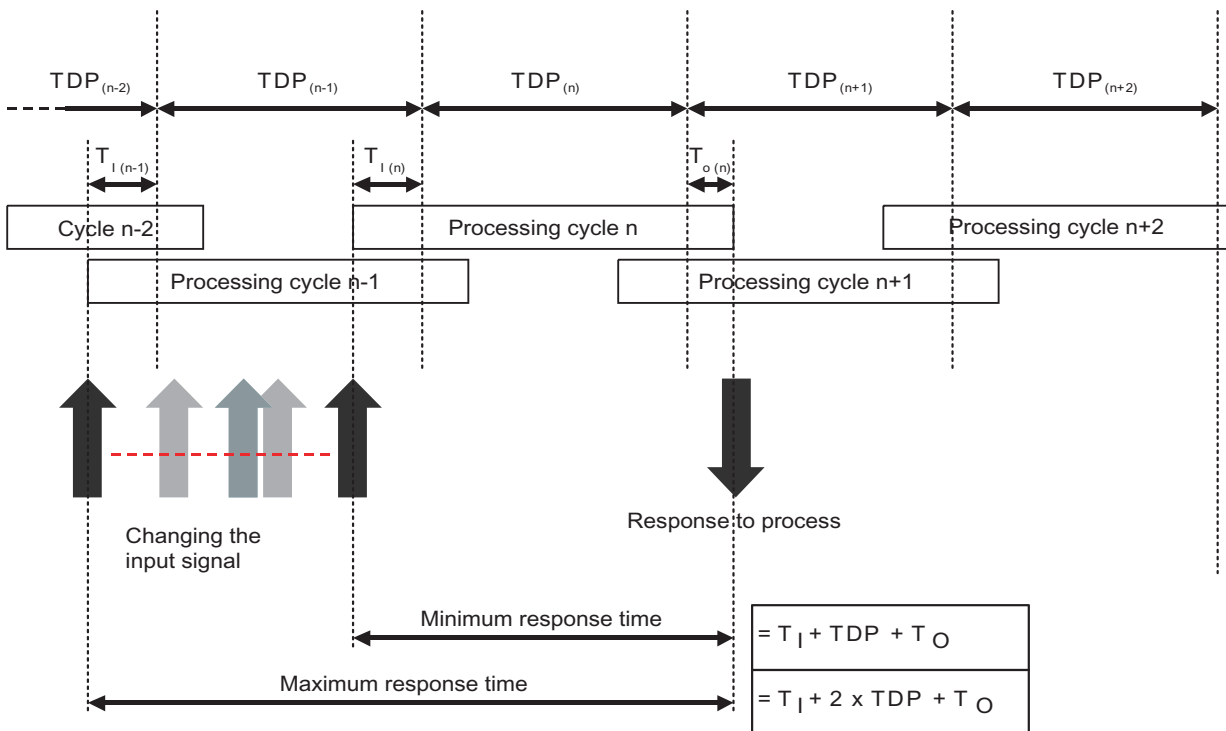

Figure 5-8 Isochronous data processing

TDP	System cycle
T_i	Time at which the input data is read
T_o	Time at which the output data is output

Synchronization of the cycles allows the input data to be read with a cycle "n-1", the data to be transferred and processed with cycle "n", and the calculated output data to be transferred and switched to the "terminals" at the start of cycle "n+1". This gives a true process response time from "Ti + TDP + To" to "Ti + (2 x TDP) + To".

The "isochrone mode" system property means that cycle times within the S7-400 system are constant; the S7-400 system is strictly deterministic on the bus system.

Just-In-Time

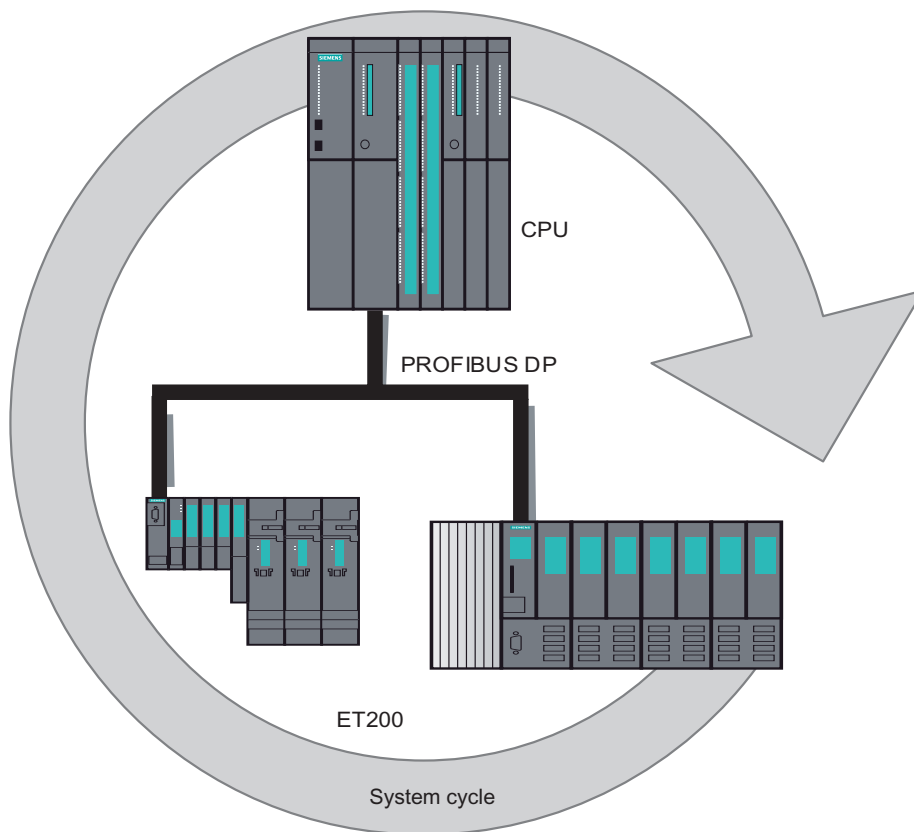

Figure 5-9 Just-In-Time

The fast and reliable response time of a system operating in isochrone mode is based on the fact that all data is provided just-in-time. The equidistant (isochronous) DP cycle forms the master clock for this.

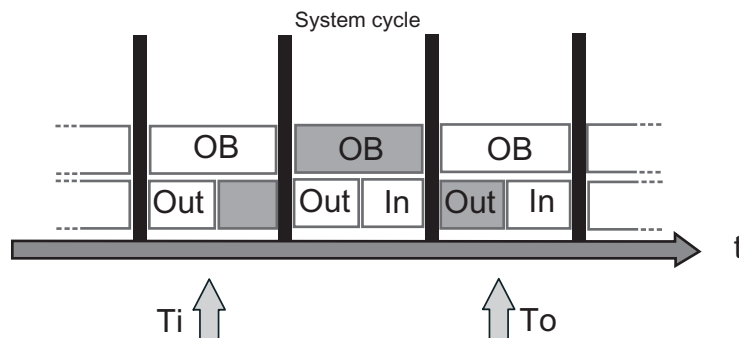

Figure 5-10 System cycle

The start of the I/O read cycle is started one bias time T_i earlier in order to make all input data available for transfer on the DP subnet at the start of the next DP cycle. You can configure this bias time T_i yourself or have it determined automatically by STEP 7.

PROFIBUS transfers the input data to the DP master via the DP subnet. The synchronous cycle interrupt OB (OB61, OB62, OB63 or OB64) is called. The user program in the synchronous cycle interrupt OB determines the process response and provides the output data in time for the start of the next DP cycle. You can configure the length of the DP cycle yourself or have it determined automatically by STEP 7.

The output data is provided just-in-time for the start of the next DP cycle. The data is transferred on the DP subnet to the DP slaves and passed to the process in an isochronous operation, that is, in synchronism with the time T_o .

The result is a total reproducible response time of " $T_i + (2 \times TDP) + T_o$ " for the transfer from the input to the output terminal.

Characteristics of isochrone mode

Isochrone mode is characterized by the three following essential features:

- The user program is synchronized with I/O processing, that is, all operations are coordinated on a time basis. All input data is logged at a defined time. The output data also takes effect at a defined time. The I/O data is synchronized with the system clock cycle up to the terminals. The data of one cycle is always processed in the next cycle, and it takes effect at the terminals in the subsequent cycle.
- I/O data is processed in equidistant (isochrone) mode, that is, input data is always read at constant intervals, and always output at the same intervals.
- All I/O data is transferred consistently, that is, all the data of a process image belongs together logically and has the same timing.

Direct access in isochrone mode

CAUTION
Avoid direct access (e.g. T PAB) to I/O areas that you process with SFC 127 "SYNC_PO". Ignoring this rule may mean that the process image partition of the outputs may not be fully updated.

PROFINET

6.1 Introduction

What is PROFINET?

PROFINET is the open, non-proprietary Industrial Ethernet standard for automation. It enables comprehensive communication from the business management level down to the field level.

PROFINET fulfills the high demands of industry, for example;

- Industrial-compliant installation engineering
- Real-time capability
- Non-proprietary engineering

There are a wide range of products from active and passive network components, controllers, distributed field devices to components for industrial wireless LAN and industrial security available for PROFINET.

With PROFINET IO a switching technology is implemented that allows all stations to access the network at any time. In this way, the network can be used much more efficiently through the simultaneous data transfer of several nodes. Simultaneous sending and receiving is enabled through the full-duplex operation of Switched Ethernet.

PROFINET IO is based on Switched Ethernet full-duplex operation and a bandwidth of 100 Mbit/s.

Documentation on the Internet:

Comprehensive information about PROFINET (<http://www.profibus.com/pn/>) is available on the Internet.

Additional information is available at the Internet address (<http://www.siemens.com/profinet/>)

6.2 PROFINET IO and PROFINET CBA

PROFINET variants

There are two PROFINET variants

- PROFINET IO: With PROFINET IO communication a part of the transfer time is reserved for cyclic, deterministic data traffic. This allows the communication cycle to be split into a deterministic portion and an open portion. Communication takes place in runtime.

PROFINET IO enables distributed field devices (IO devices such as signal modules) to be connected directly to Industrial Ethernet. PROFINET IO supports a uniform diagnostics concept which permits efficient fault locating and troubleshooting.

- PROFINET CBA: A component-based automation solution in which complete technological modules are used as standardized components in large plants. This simplifies inter-device communication. You create the CBA components in SIMATIC with STEP 7 and the SIMATIC iMap add-on package. You interconnect the individual components with SIMATIC iMap.

When you download CBA interconnections to an S7-400 CPU, they are stored in the RAM, rather than on the memory card. The interconnections are lost if there is defective hardware, a memory reset or firmware update. In this case you will have to download the interconnections again using SIMATIC iMAP.

If you use PROFINET CBA, you cannot use isochrone mode or carry out configuration changes at runtime.

PROFINET IO and PROFINET CBA

PROFINET IO and PROFINET CBA are two different views of automation devices on Industrial Ethernet.

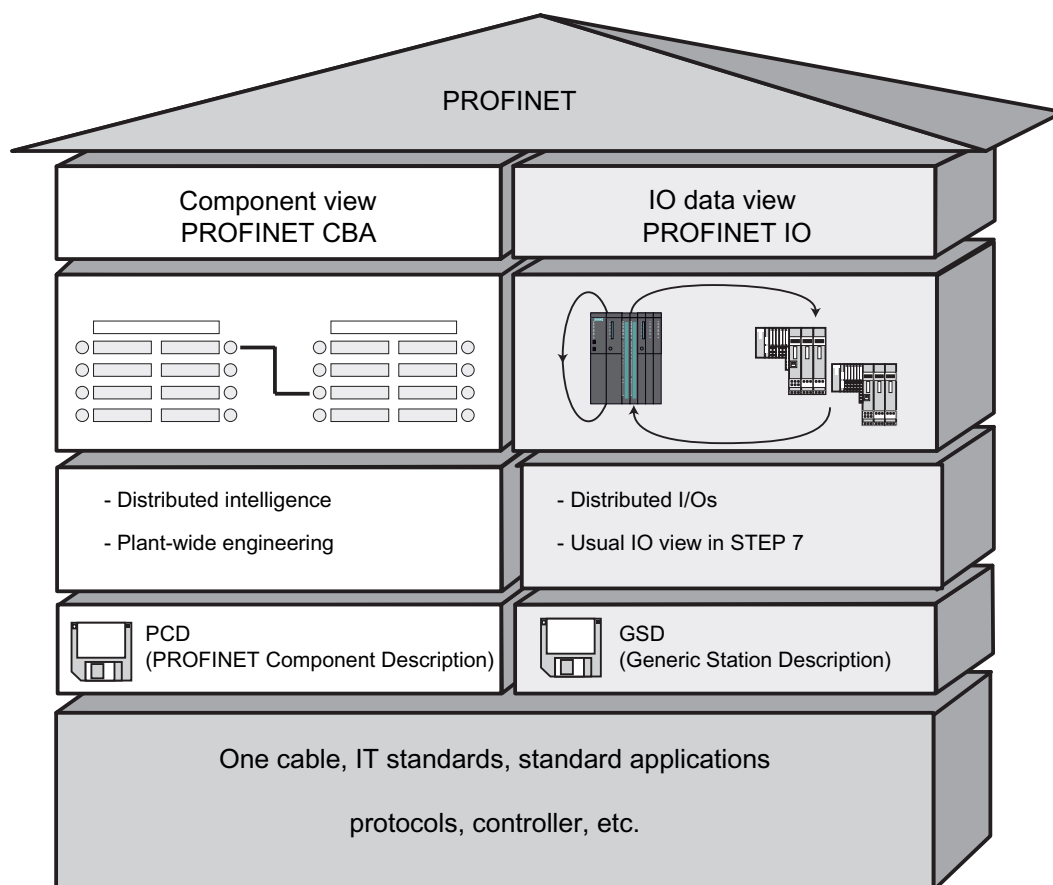

Figure 6-1 PROFINET IO and PROFINET CBA

PROFINET CBA divides an entire plant into various functions. These functions are configured and programmed.

PROFINET IO provides an image of the system that is very similar to the view obtained in PROFIBUS. You continue to configure and program the individual automation devices.

Reference

- Additional information about PROFINET IO and PROFINET CBA is available in the *PROFINET System Description*.
- Differences between and common properties of the PROFIBUS DP and PROFINET IO are described in the *From PROFIBUS DP to PROFINET IO Programming Manual*.
- For additional information about PROFINET CBA, refer to the documentation on SIMATIC iMAP and Component Based Automation.

6.3 PROFINET IO Systems

Extended Functions of PROFINET IO

The graphic below shows the new functions of PROFINET IO.

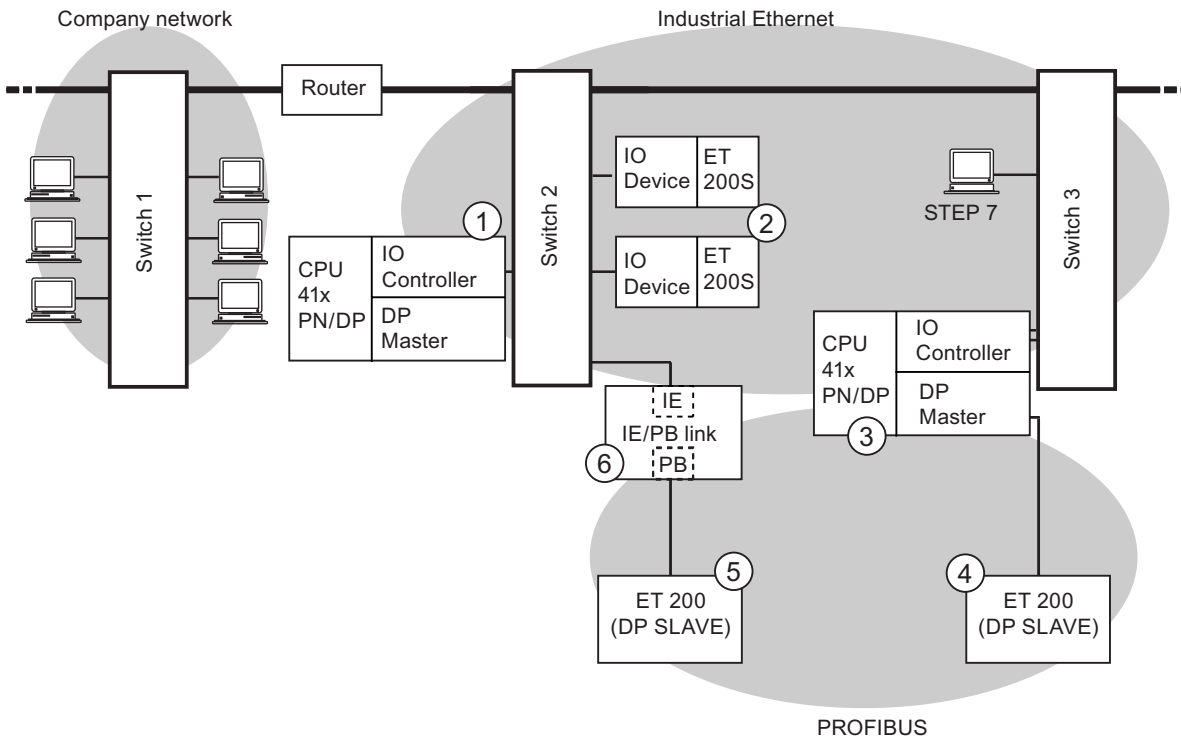

Figure 6-2 PROFINET IO

The figure shows	Examples of connection paths
The connection of company network and field level	You can use PCs in your company network to access devices at the field level, e.g. to display the diagnostic buffer in a web browser. Example: <ul style="list-style-type: none"> PC - Switch 1 - Router - Switch 2 - CPU 41x PN/DP ①.
The connection between the automation system and field level	You can also access one of the other areas in Industrial Ethernet from an IO supervisor at the field level. Example: <ul style="list-style-type: none"> IO-Supervisor - Switch 3 - Switch 2 - on an IO device of the ET 200S ②.

The figure shows	Examples of connection paths
The IO controller of the CPU 41x PN/DP ① directly controls devices on the Industrial Ethernet and on the PROFIBUS	<p>At this point, you see the extended IO feature between the IO controller and IO device(s) on Industrial Ethernet:</p> <ul style="list-style-type: none"> • The CPU 41x PN/DP ① is the IO controller for one of the ET 200S ② IO devices. • The CPU 41x PN/DP ① is also the IO controller for the ET 200 (DP slave) ⑤ via the IE/PB Link ⑥.
A CPU can be both IO controller and DP master.	<p>Here, you can see that a CPU can be both IO controller for an IO device as well as DP master for a DP slave:</p> <ul style="list-style-type: none"> • The CPU 41x PN/DP ③ is the IO controller for the other ET 200S ② IO devices. CPU 41x PN/DP ③ - Switch 3 - Switch 2 - ET 200S ② • The CPU 41x PN/DP ③ is the DP master for a DP slave ④. The DP slave ④ is assigned locally to the CPU ③ and is not visible on Industrial Ethernet.

Reference

For further information about PROFINET refer to the *From PROFIBUS DP to PROFINET IO programming manual*.

This manual also provides a comprehensive overview of the new PROFINET blocks and system status lists.

6.4 Blocks in PROFINET IO

Compatibility of the New Blocks

For PROFINET IO, some new blocks were created, among other things, because larger configurations are now possible with PROFINET. You can also use the new blocks with PROFIBUS.

Comparison of the System and Standard Functions of PROFINET IO and PROFIBUS DP

For CPUs with an integrated PROFINET interface, the table below provides you with an overview of the following functions:

- System and standard functions for SIMATIC that you may need to replace when converting from PROFIBUS DP to PROFINET IO.
- New system and standard functions

Table 6- 1 New System and Standard Functions/System and Standard Functions to be Replaced

Blocks	PROFINET IO	PROFIBUS DP
SFC 12 "D_ACT_DP" Deactivation and activation of DP slaves/IO devices	Yes S7-400: As of firmware V5.0	Yes
SFC13 "DPNRM_DG" Read diagnostic data of a DP slave	No Replacement: • Event-related: SFB 54 • State-related: SFB 52	Yes
SFC 58 "WR_REC" SFC 59 "RD_REC" Write/read record in the I(O) devices.	No Replacement: SFB 53/52	Yes, if you will have not already replaced these SFBs under DPV 1 by SFB 53/52.
SFB 52 "RDREC" SFB53 "WRREC" Read/write record	Yes	Yes
SFB 54 "RALRM" Evaluate interrupts	Yes	Yes
SFB 81 "RD_DPAR" Read predefined parameters	Yes	Yes
SFC 5 "GADR_LGC" Query start address of a module	No Replacement: SFC 70	Yes
SFC 70 "GEO_LOG" Query start address of a module	Yes	Yes

Blocks	PROFINET IO	PROFIBUS DP
SFC 49 "LGC_GADR" Query the slot belonging to a logical address	No Substitute: SFC 71	Yes
SFC 71 "LOG_GEO" Determine the module slot belonging to a logical address	Yes	Yes

The following table provides an overview of the system and standard functions for SIMATIC, whose functionality must be implemented by other functions when converting from PROFIBUS DP to PROFINET IO.

Table 6- 2 System and Standard Functions in PROFIBUS DP that must be Implemented with Different Functions in PROFINET IO

Blocks	PROFINET IO	PROFIBUS DP
SFC 54 "RD_DPARM" Read predefined parameters	No Replacement: SFB 81 "RD_DPAR"	Yes
SFC55 "WR_PARM" Write dynamic parameters	No Replicate via SFB 53	Yes
SFC56 "WR_DPARM" Write predefined parameters	No Replicate via SFB 81 and SFB 53	Yes
SFC57 "PARM_MOD" Assigning module parameters	No Replicate via SFB 81 and SFB 53	Yes

You cannot use the following SIMATIC system and standard functions with PROFINET IO:

- SFC 7 "DP_PRAL" Trigger hardware interrupt on DP master
- SFC 11 "DPSYC_FR" Synchronize groups of DP slaves
- SFC 72 "I_GET" Read data from a communication partner within local S7 station
- SFC 73 "I_PUT" Write data to a communication partner within local S7 station
- SFC 74 "I_ABORT" Abort an existing connection to a communication partner within local S7 station
- SFC 103 "DP_TOPOL" Determine the bus typology in a DP master

Comparison of the Organization Blocks of PROFINET IO and PROFIBUS DP

The following table lists the changes at OBs 83 und OB 86:

Table 6- 3 OBs in PROFINET IO and PROFIBUS DP

Blocks	PROFINET IO	PROFIBUS DP
OB 83 Removing and inserting modules during operation	New error information	Unchanged
OB 86 Rack failure	New error information	Unchanged

Detailed Information

For detailed descriptions of the individual blocks, refer to the manual *System Software for S7-300/400 System and Standard Functions*.

6.5 System status lists for PROFINET IO

Introduction

The CPU makes certain information available and stores this information in the "System status list".

The system status list describes the current status of the automation system. It provides an overview of the configuration, the current parameter assignment, the current statuses and sequences in the CPU, and the assigned modules.

The system status list data can only be read, but not be changed. The system status list is a virtual list that is compiled only on request.

From a system status list you receive the following information via the PROFINET IO system:

- System data
- Module status information in the CPU
- Diagnostic data from a module
- Diagnostic buffer

Compatibility of the new system status lists

For PROFINET IO, some new system status lists were created, among other things, because larger configurations are now possible with PROFINET.

You can also use these new system status lists with PROFIBUS.

You can continue to use a known PROFIBUS system status list that is also supported by PROFINET. If you use a system status list in PROFINET that PROFINET does not support, an error code is returned in RET_VAL (8083: Index wrong or not permitted).

Comparison of the system status lists of PROFINET IO and PROFIBUS DP

Table 6- 4 Comparison of the system status lists of PROFINET IO and PROFIBUS DP

SSL-ID	PROFINET IO	PROFIBUS DP	Applicability
W#16#0591	Yes Parameter adr1 changed	Yes	Module status information for the interfaces of a module
W#16#0C91	Yes, internal interface Parameter adr1/adr2 and set/actual type identifier changed No, external interface	Yes, internal interface No, external interface	Module status information of a module in a central configuration or attached to an integrated DP or PN interface, or an integrated DP interface using the logical address of the module.
W#16#4C91	No, internal interface Yes, external interface Parameter adr1 changed	No, internal interface Yes, external interface	Module status information of a module attached to an external DP or PN interface using the start address
W#16#0D91	Yes Parameter adr1 changed No, external interface	Yes	Module status information of all modules in the specified rack/station

6.5 System status lists for PROFINET IO

SSL-ID	PROFINET IO	PROFIBUS DP	Applicability
W#16#0696	Yes, internal interface No, external interface	No	Module status information of all submodules on an internal interface of a module using the logical address of the module, not possible for submodule 0 (= module)
W#16#0C96	Yes	Yes, internal interface No, external interface	Module status information of a submodule using the logical address of this submodule
W#16#xy92	No Replacement: SSL-ID W#16#0x94	Yes	Rack/stations status information Replace this system status list with the system status list with ID W#16#xy94 in PROFIBUS DP, as well.
W#16#0x94	Yes	No	Rack/station status information

Detailed information

For detailed descriptions of the individual system status lists, refer to the manual *System Software for S7-300/400 System and Standard Functions*.

Consistent Data

7.1 Basics

Overview

Data that belongs together in terms of its content and describes a process state at a specific point in time is known as consistent data. To maintain consistency, the data should not be changed or updated during processing or transmission.

Example

To ensure that the CPU has a consistent image of the process signals for the duration of cyclic program scanning, the process signals are read from the process image inputs prior to program scanning and written to the process image outputs after the program scanning. Subsequently, during program scanning when the address area "inputs" (I) and "outputs" (O) are addressed, the user program addresses the internal memory area of the CPU on which the image of the inputs and outputs is located instead of directly accessing the signal modules.

SFC 81 "UBLKMOV"

With SFC 81 "UBLKMOV" (uninterruptible block move), you can copy the contents of a memory area (= source area) consistently to a different memory area (= destination area). The copy operation cannot be interrupted by other operating system activities.

SFC 81 "UBLKMOV" enables you to copy the following memory areas:

- Bit memory
- DB contents
- Process Image of Inputs
- Process Image of Outputs

The maximum amount of data you can copy is 512 bytes. Remember the restrictions for the specific CPU as described, for example, in the operations list.

Since copying cannot be interrupted, the interrupt reaction times of your CPU may increase when using SFC 81 "UBLKMOV".

The source and destination areas must not overlap. If the specified destination area is larger than the source area, the function only copies as much data to the destination area as that contained in the source area. If the specified destination area is smaller than the source area, the function only copies as much data as can be written to the destination area.

For information on SFC81, refer to the corresponding online help and to the *System and Standard Functions* manual.

7.2 Consistency for communication blocks and functions

Overview

Using S7-400, the communication jobs are not processed at the scan cycle checkpoint; instead, in fixed time slices during the program cycle.

In the system the byte, word and double word data formats can always be processed consistently, in other words, the transfer or processing of 1 byte, 1 word (= 2 bytes) or 1 double word (= 4 bytes) cannot be interrupted.

If communication blocks (such as SFB¹² "BSEND") are called in the user program, which are only used in pairs (such as SFB 12 "BSEND" and SFB 13 "BRCV") and which share access to data, the access to this data area can be coordinated between themselves, for example, using the "DONE" parameter. Data consistency of the communication areas transmitted locally with a communication block can thus be ensured in the user program.

S7 communication functions such as SFB 14 "GET", SFB 15 "PUT" react differently because no block is needed in the user program of the destination device. In this case the size of data consistency has to be taken into account beforehand during the programming phase.

Access to the Work Memory of the CPU

The communication functions of the operating system access the work memory of the CPU in fixed field lengths. The field size is a variable length up to a maximum of 462 bytes.

7.3 Consistent Reading and Writing of Data from and to DP Standard Slaves/IO Devices

Reading Data Consistently from a DP Standard Slave/IO Device Using SFC 14 "DPRD_DAT"

Using SFC14 "DPRD_DAT" (read consistent data of a DP standard slave) you can consistently read the data of a DP standard slave.

If no error occurred during the data transmission, the read data is entered in the destination area defined by RECORD.

The destination area must be the same length as the one you configured for the selected module with *STEP 7*.

By invoking SFC14 you can only access the data of one module / DP ID at the configured start address.

For information on SFC14, refer to the corresponding online help and to the *System and Standard Functions* manual

Writing Data Consistently to a DP Standard Slave/IO Device Using SFC 15 "DPWR_DAT"

Using SFC 15 "DPWR_DAT" (write consistent data to a DP standard slave) you can consistently write data to the DP standard slave or IO device addressed in the RECORD.

The source area must be the same length as the one you configured for the selected module with *STEP 7*.

Upper Limit for the Transmission of Consistent User Data to a DP Slave

The PROFIBUS DP standard defines the upper limit for the transmission of consistent user data to a DP slave. For this reason a maximum of 64 words = 128 bytes of user data can be consistently transferred in a block to the DP slave.

During the configuration you can determine the size of the consistent area. You can set a maximum length of consistent data at 64 words = 128 bytes in the special identification format (SKF) (128 bytes for inputs and 128 bytes for outputs); the data block size cannot exceed this.

This upper limit only applies to pure user data. Diagnostics and parameter data is regrouped into full records and therefore always transferred consistently.

In the general identification format (AKF) the maximum length of consistent data can be set at 16 words = 32 bytes (32 bytes for inputs and 32 bytes for outputs); the data block size cannot exceed this.

Note in this context that a CPU 41x in a general environment acting as a DP slave on a third-party master (connection defined by GSD) has to be configured with the general identification format. The transfer memory for each virtual slot of a CPU 41x acting as a DP slave to the PROFIBUS DP can therefore be a maximum of 16 words = 32 bytes. Up to 32 such virtual slots can be configured in the i slave; the highest slot number is 35.

For information on SFC 15, refer to the corresponding online help and to the *System and Standard Functions* manual

Note

The PROFIBUS DP standard defines the upper limit for the transmission of consistent user data. Typical DP standard slaves adhere to this upper limit. In older CPUs (<1999) there are restrictions in the transmission of consistent user data depending on the CPU. For these CPUs you can determine the maximum length of the data which the CPU can consistently read and write to and from the DP standard in the respective technical specifications under the index entry "DP Master – User data per DP slave". Newer CPUs are capable of exceeding the value for the amount of data that a DP standard slave can send and receive.

Upper Limit for the Transmission of Consistent User Data to a IO Device

There is a 255 bytes upper limit for the transmission of consistent user data on an IO device (254 bytes user data + 1 byte associated value). Even when more than 255 bytes can be transmitted on an IO device, only a maximum of 255 bytes can be consistently transmitted.

There is an upper limit of 240 bytes for transfer via a CP 443-1 EX41.

Consistent Data Access without the Use of SFC 14 or SFC 15

Consistent data access of > 4 bytes without using SFC 14 or SFC 15 is possible for the CPUs described in this manual. The data area of a DP slave or IO devices that should transfer consistently is transferred to a process image partition. The information in this area is therefore always consistent. You can subsequently use load/transfer commands (such as L IW 1) to access the process image. This is an especially convenient and efficient (low runtime load) way to access consistent data. This allows efficient integration and configuration of drives or other DP slaves, for example.

An I/O access error does **not** occur with direct access (e.g. L PIW or T PQW).

The following is important for converting from the SFC14/15 method to the process image method:

- SFC 50 "RD_LGADR" outputs another address area with the SFC 14/15 method as with the process image method.
- PROFIBUS DP via Interface interface:
When converting from the SFC14/15 method to the process image method, it is not recommended to use the system functions and the process image at the same time. Although the process image is updated when writing with the system function SFC15, this is not the case when reading. In other words, the consistency between the process image values and the values of the system function SFC14 is not ensured.
- PROFIBUS-DP via CP 443-5 Extended:
If you are using a CP 443-5 ext, the simultaneous use of SFC14/15 and the process image results in the following errors; you cannot read/write to the process image consistently and you can no longer read/write with SFC 14/15 consistently.

Note**Forcing variables**

Forcing variables which lie in the I/O or process image range of a DP slave or IO device and which belong to a consistency range is not permitted. The user program may overwrite these variables in spite of the force job.

Example

The following example (of the process image partition 3 "TPA 3") shows such a configuration in HW Config.

Requirement: The process image was previously updated via SFC 26/27 or updating of the process image was linked to an OB.

- TPA 3 at output: These 50 bytes are stored consistent in the process image partition 3 (pull-down list "Consistent over -> entire length") and can therefore be read through the normal "load input xy" commands.
- Selecting "Process Image Partition -> ---" under input in the pull-down menu means: do not store in a process image. Then the handling can only be performed using the system functions SFC14/15.

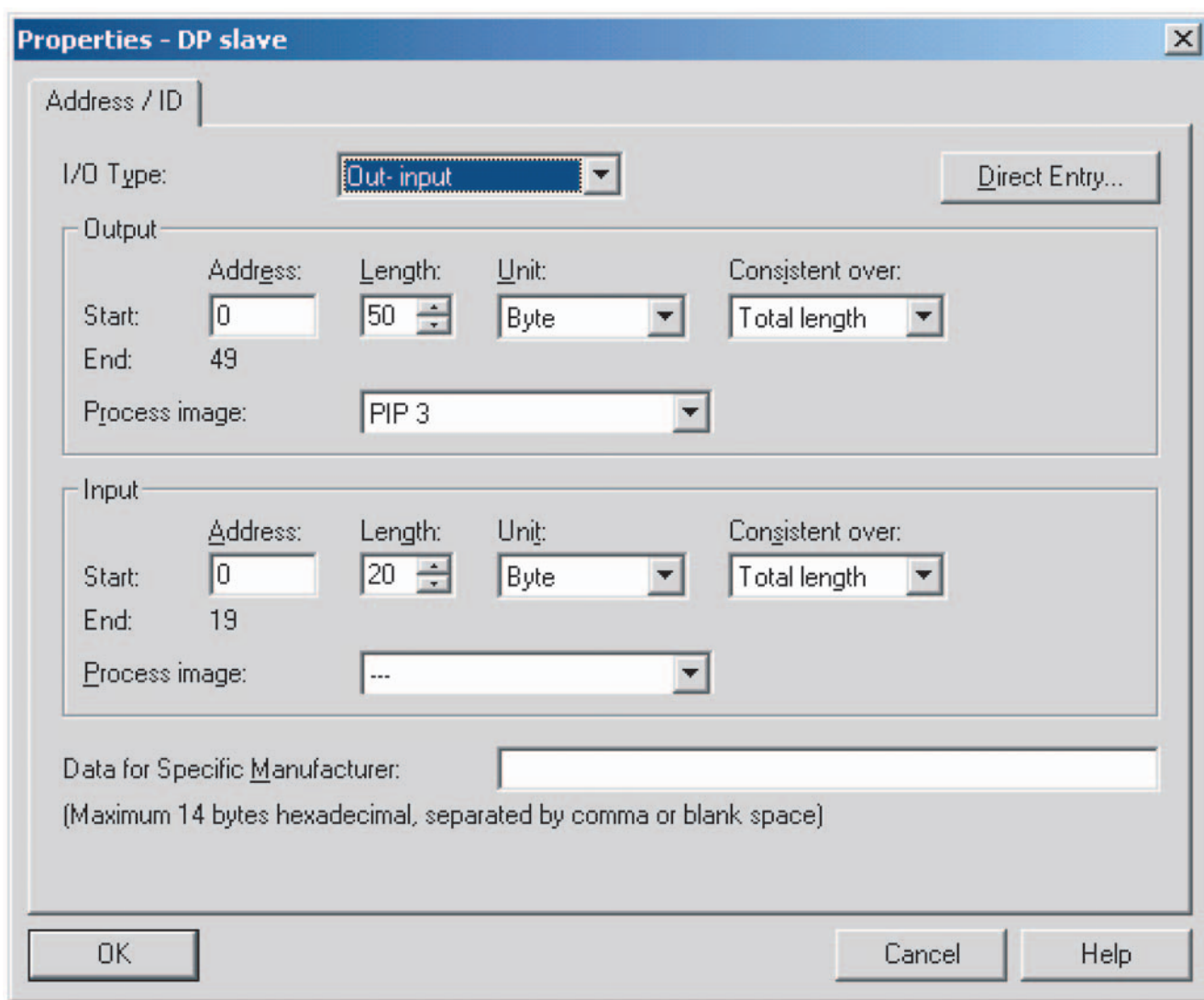

Memory concept

8.1 Overview of the memory concept of S7-400 CPUs

Organization of Memory Areas

The memory of the S7 CPUs can be divided into the following areas:

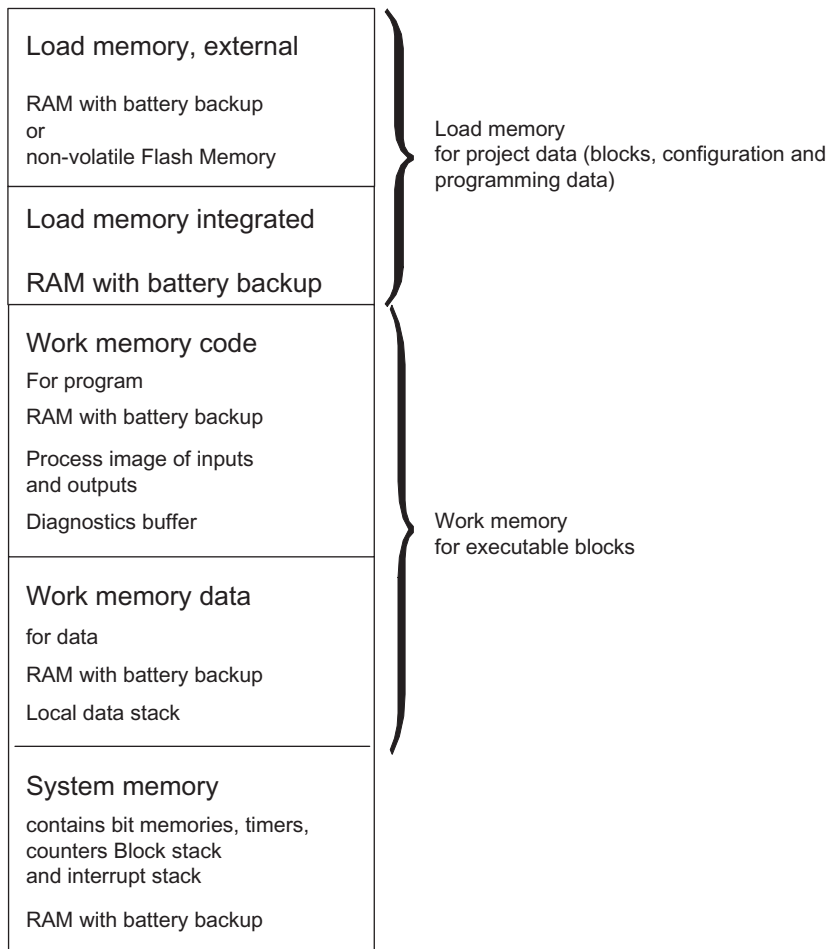

Figure 8-1 Memory areas of S7-400 CPUs

Memory Types in S7-400 CPUs

- Load memory for the project data, e.g. blocks, configuration and parameter settings.
- Work memory for the runtime-relevant blocks (logic blocks and data blocks).
- System memory (RAM) contains the memory elements that each CPU makes available to the user program, such as bit memory, timers and counters. System memory also contains the block stack
- System memory of the CPU also makes temporary memory available (local data stack, diagnostic buffer and communication resources) that is assigned to the program for the temporary data of a called block. These data is only valid as long as the block is active.

By changing the default values for the process image, local data, diagnostic buffer and communication resources (see object properties of the CPU in HW Config), you can influence the work memory available to the runtime-relevant blocks.

NOTICE
Please note the following if you expand the process image of a CPU. Reconfigure modules whose addresses have to be over the highest address of the process image so that the new addresses are still over the highest address of the expanded process image. This applies, in particular, to IP and WF modules that you operate in the S5 adapter casing in an S7-400.

Important note for CPUs after the parameter settings for the allocation of RAM have been changed

If you change the work memory allocation by modifying parameters, this work memory is reorganized when you load system data into the CPU. The result of this is that data blocks that were created with SFC are deleted, and the remaining data blocks are assigned initial values from the load memory.

The usable size of the working memory for logic or data blocks is changed when loading the system data if you change the following parameters:

- Size of the process image (byte-oriented; in the "Cycle/Clock Memory" tab)
- Communication resources (S7-400 only; "Memory" tab)
- Size of the diagnostic buffer ("Diagnostics/Clock" tab)
- Number of local data for all priority classes ("Memory" tab)

Basis for Calculating the Required Working Memory

To ensure that you do not exceed the available amount of working memory on the CPU, you must take into consideration the following memory requirements when assigning parameters:

Table 8-1 Memory requirements

Parameters	Required working memory	In code/data memory
Size of the process image (inputs)	12 bytes per byte in the process input image	Code memory
Size of the process image (outputs)	12 bytes per byte in the process output image	Code memory
Communication resources (communication jobs)	72 bytes per communication job	Code memory
Size of the diagnostic buffer	32 bytes per entry in the diagnostic buffer	Code memory
Quantity of local data	1 byte per byte of local data	Data memory

Flexible Memory Capacity

- **Work memory:**
The capacity of the work memory is determined by selecting the appropriate CPU from the graded range of CPUs.
- **Load memory:**
The integrated load memory is sufficient for small and medium-sized programs.
The load memory can be increased for larger programs by inserting the RAM memory card.
Flash memory cards are also available to ensure that programs are retained in the event of a power failure even without a backup battery. Flash memory cards (8 MB or more) are also suitable for sending and carrying out operating system updates.

Backup

- The backup battery provides backup power for the integrated and external part of the load memory, the data section of the working memory and the code section.

Cycle and Response Times of the S7-400

9.1 Cycle time

Definition of the Cycle Time

The cycle time represents the time that an operating system needs to execute a program, that is, one OB 1 cycle, including all program sections and system activities interrupting this cycle.

This time is monitored.

Time-Sharing Model

Cyclic program scanning, and thus also processing of the user program, is performed in time slices. So that you can better appreciate these processes, we will assume in the following that each time slice is exactly 1 ms long.

Process Image

The process signals are read or written prior to program scanning so that a consistent image of the process signals is available to the CPU for the duration of cyclic program scanning. Then the CPU does not directly access the signal modules during program scanning when the address area "inputs" (I) and "outputs" (O) are addressed, but addresses instead the internal memory area of the CPU on which the image of the inputs and outputs is located.

The Cyclic Program Scanning Process

The following table and figure illustrate the phases of cyclic program scanning.

Table 9- 1 Cyclic program processing

Step	Process
1	The operating system starts the scan cycle monitoring time.
2	The CPU writes the values from the process-image output table in the output modules.
3	The CPU reads out the status of the inputs at the input modules and updates the process-image input table.
4	The CPU processes the user program in time slices and performs the operations specified in the program.
5	At the end of a cycle, the operating system executes pending tasks, such as the loading and clearing of blocks.
6	The CPU then goes back to the beginning of the cycle after the configured minimum cycle time, as necessary, and starts cycle time monitoring again.

Parts of the Cycle Time

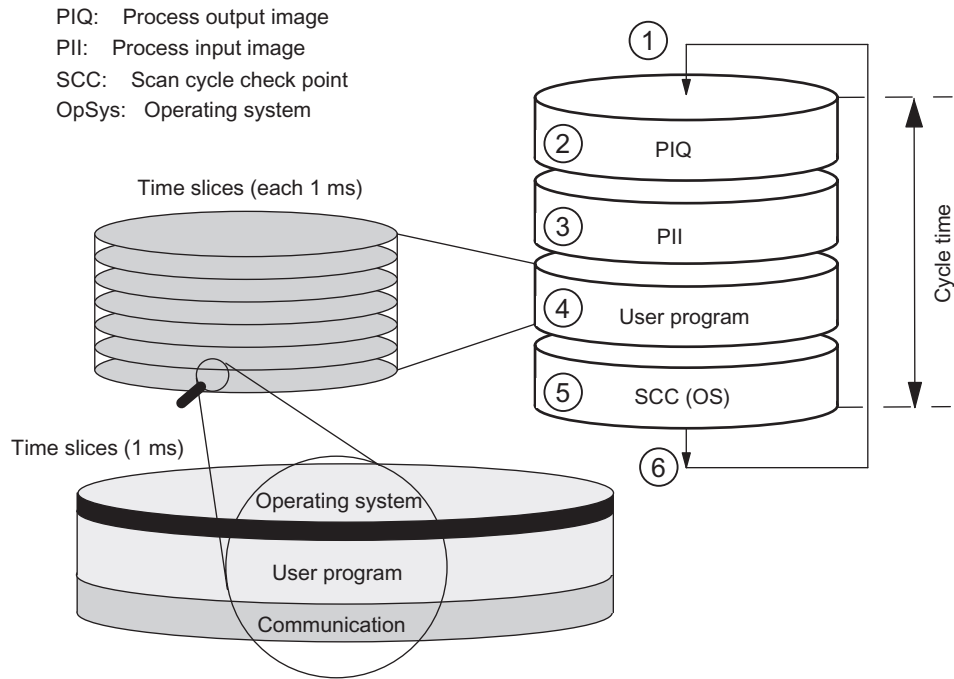

Figure 9-1 Parts and Composition of the Cycle Time

9.2 Cycle Time Calculation

Increasing the Cycle Time

Basically, you should note that the cycle time of a user program is increased by the following:

- Time-driven interrupt processing
- Hardware interrupt processing
- Diagnostics and error handling
- Communications via the MPI, PROFINET interface and CPs connected automation-system internally (for example, Ethernet, PROFIBUS DP); included in the communication load
- Special functions such as control and monitoring of tags or block status
- Transfer and clearance of blocks, compression of the user program memory
- Internal memory test

Influencing factors

The following table indicates the factors that influence the cycle time.

Table 9- 2 Factors that Influence the Cycle Time

Factors	Remarks
Transfer time for the process-image output table (PIQ) and the process-image input table (PII)	... See table 9.3 "Portions of the process image transfer time"
User program execution time	... is calculated from the execution times of the different instructions, see <i>S7-400 Instruction List</i> .
Operating system scan time at the scan cycle checkpoint	... See table 9.4 "Operating system scan time at the scan cycle checkpoint"
Increase in the cycle time through communications	You set the maximum permissible cycle load expected for communication in % in <i>STEP 7</i> , see manual <i>Programming with STEP 7</i> .
Impact of interrupts on the cycle time	Interrupt can interrupt the user program at any time. ... See table 9.5 "Increase in cycle time by nesting interrupts"

9.2 Cycle Time Calculation

Process image update

The table below shows the CPU times for process image updating (process image transfer time). The times listed in the table are "ideal values" that may be increased by the occurrence of interrupts and by CPU communications.

The transfer time for process image updating is calculated as follows

- C + portion in the central rack (from row A in the following table)
- + portion in the expansion rack with local connection (from row B)
- + portion in the expansion rack with remote connection (from row C)
- + portion via integrated DP interface (from row D)
- + portion of consistent data via integrated DP interface (from row E1)
- + portion of consistent data via external DP interface (from row E2)
- + portion via integrated PN/IO interface (from row F1)
- + portion via external PN/IO interface (from row F2)

= Transfer time for the process image update

The tables below show the individual portions of the transfer time process image updating (process image transfer time). The times listed in the table are "ideal values" that may be increased by the occurrence of interrupts and by CPU communications.

Table 9- 3 Portions of the process image transfer time

Portions		CPU 412	CPU 414	CPU 416	CPU 417
	n = number of bytes in the process image				
C	Base load	14 μs	7 μs	5 μs	3 μs
O	In the central rack *)	n * 1.9 μs	n * 1.8 μs	n * 1.75 μs	n * 1.7 μs
B	In the expansion rack with local connection *)	n * 5.6 μs	n * 5.5 μs	n * 5.4 μs	n * 5.3 μs
C	In the expansion rack with remote connection *)**)				
	Reading	n * 12 μs	n * 12 μs	n * 12 μs	n * 12 μs
	Writing	n * 11 μs	n * 11 μs	n * 11 μs	n * 11 μs
D 1	In the DP area for the integrated DP interface	n * 0.75 μs	n * 0.5 μs	n * 0.45 μs	n * 0.45 μs
D 2	In the DP area for the external DP interface CP 443-5 extended	n * 2.7 μs	n * 2.5 μs	n * 2.4 μs	n * 2.2 μs
E 1	Consistent data in the process image for the integrated DP interface	n * 0.8 μs	n * 0.45 μs	n * 0.3 μs	n * 0.2 μs
E 2	Consistent data in the process image for the external DP interface (CP 443-5 extended)	n * 2.0 μs	n * 2.0 μs	n * 2.0 μs	n * 1.8 μs
F 1	In the PN/IO area for the integrated interface	-	n * 5.6 μs	n * 5.6 μs	-
F 2	In the PN/IO area for the external interface CP 443-1 EX 41	n * 3.4 μs	n * 3.1 μs	n * 2.8 μs	n * 2.6 μs
*)In the case of I/O modules that are plugged into the central rack or an expansion rack, the specified value contains the runtime of the I/O module **)Measured with the IM 460-3 and IM 461-3 with a connection length of 100 m					

Operating System Scan Time at the Scan Cycle Checkpoint

The table below lists the operating system scan times at the scan cycle checkpoint of the CPUs.

Table 9- 4 Operating System Scan Time at the Scan Cycle Checkpoint

Process	CPU 412	CPU 414	CPU 416	CPU 417
Scan cycle control at the SCC	213 µs to 340 µs Ø 231 µs	160 µs to 239 µs Ø 168 µs	104 µs to 163 µs Ø 109 µs	49 µs to 87 µs Ø 52 µs

Increase in cycle time by nesting interrupts

Table 9- 5 Increase in cycle time by nesting interrupts

CPU	Hardware interrupt	Diagnostic interrupt	Time-of-day Interrupt	Time-delay interrupt	Cyclic interrupt	Programming / PI/O access error
CPU 412-1/-2	529 µs	524 µs	471 µs	325 µs	383 µs	136 µs / 136 µs
CPU 414-2/-3	314 µs	308 µs	237 µs	217 µs	210 µs	84 µs / 84 µs
CPU 416-2/-3	213 µs	232 µs	139 µs	135 µs	141 µs	55 µs / 56 µs
CPU 417-4	150 µs	156 µs	96 µs	75 µs	92 µs	32 µs / 32 µs

You will have to add the program execution time at the interrupt level to this increase.

If several interrupts are nested, their times must be added together.

9.3 Different cycle times

Fundamentals

The length of the cycle time (T_{cyc}) is not identical in each cycle. The following figure shows different cycle times, T_{cyc1} and T_{cyc2} . T_{cyc2} is longer than T_{cyc1} , because the cyclically scanned OB 1 is interrupted by a time-of-day interrupt OB (here, OB10).

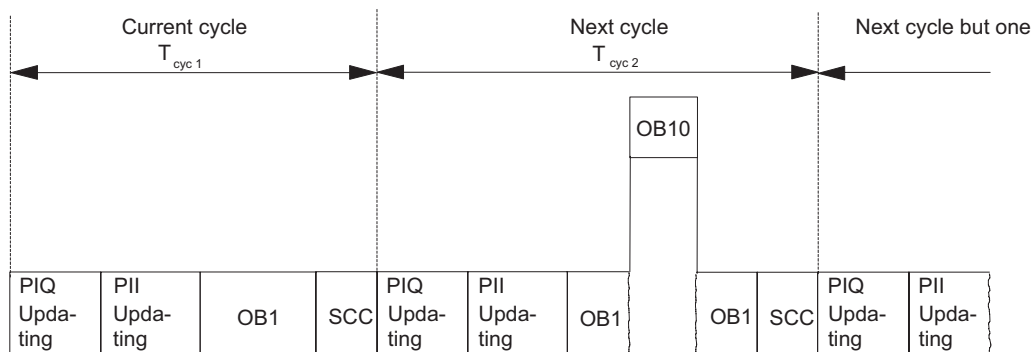

Figure 9-2 Different cycle times

Fluctuation of the block processing time (e.g. OB 1) may also be a factor causing cycle time fluctuation, due to:

- Conditional commands
- Conditional block calls
- Different program paths,
- Loops, etc.

Maximum Cycle Time

You can modify the default maximum cycle time in STEP 7 (cycle monitoring time). When this time has expired, OB 80 is called. In OB 80 you can specify how the CPU is to react to time errors. If you do not retrigger the cycle time with SFC43, OB 80 doubles the cycle time at the first call. In this case, the CPU goes to STOP at the second call of OB 80.

If there is no OB 80 in the CPU memory, the CPU goes to STOP.

Minimum Cycle Time

You can set a minimum cycle time for a CPU in STEP 7. This is appropriate in the following cases:

- you want the intervals of time between the start of program scanning of OB1 (free cycle) to be roughly of the same length.
- updating of the process images would be performed unnecessarily often with too short a cycle time.
- You want to process a program with the OB 90 in the background.

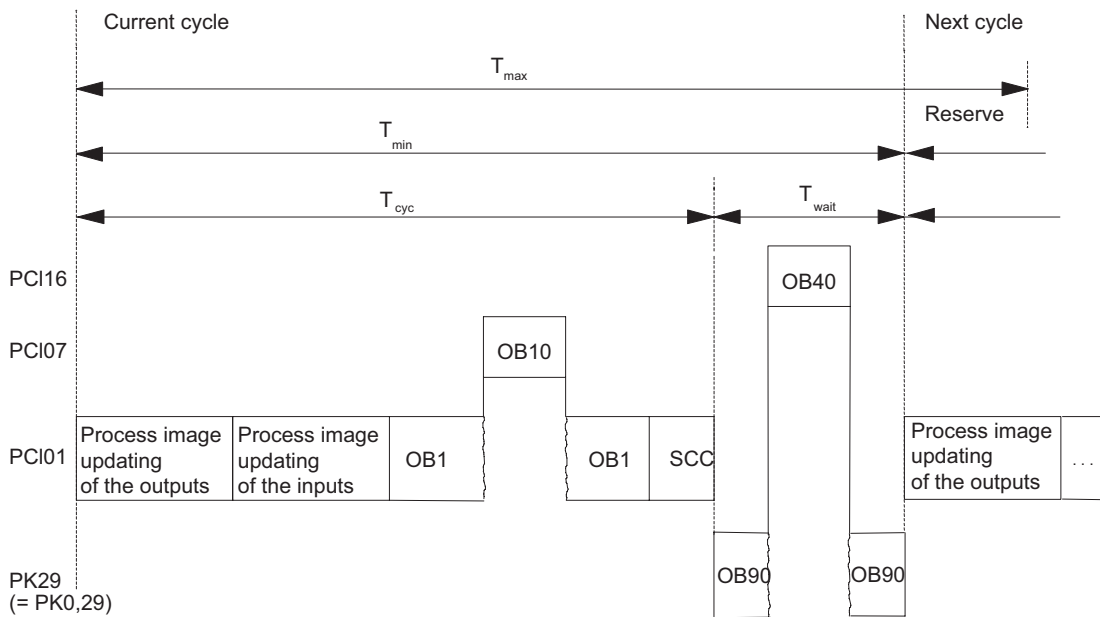

T_{min} = the adjustable minimum cycle time
 T_{max} = the adjustable maximum cycle time
 T_{cyc} = the cycle time
 T_{wait} = the difference between T_{min} and the actual cycle time; in this time, any interrupts that occur, the background OB and the SCC tasks can be processed.
 PCI = priority class

Figure 9-3 Minimum cycle time

The actual cycle time is the sum of T_{cyc} and T_{wait} . It is always greater than or equal to T_{min} .

9.4 Communication Load

Overview

The CPU operating system continually makes available to communications the percentage you configured for the overall CPU processing performance (time sharing). Processing performance not required for communication is made available to other processes.

In the hardware configuration, you can set the load due to communications between 5% and 50%. By default, the value is set to 20%.

This percentage should be regarded as an average value, in other words, the communications component can be considerably greater than 20% in a time slice. On the other hand, the communications component in the next time slice is only a few or zero percent.

This fact is also expressed by the following equation:

$$\text{Actual cycle time} = \text{Cycle time} \times \frac{100}{100 - \text{"configured communication load in \%\"}}$$

Round up the result to the next whole number !

Figure 9-4 Equation: Influence of communication load

Note

Real and configured communication load

The configured communication load alone has no effect on the cycle time. The cycle time is only influenced by the communication load actually occurring. In other words, when a communication load of 50% is configured and a communication load of 10% occurs in a cycle, the cycle time is not doubled, it only increases by a factor of 1.1.

Data consistency

The user program is interrupted for communications processing. The interrupt can be executed after any instruction. These communication jobs can modify the program data. This means that the data consistency cannot be guaranteed for the duration of several accesses.

The section *Consistent Data* provides more information about how to ensure consistency when there is more than one command.

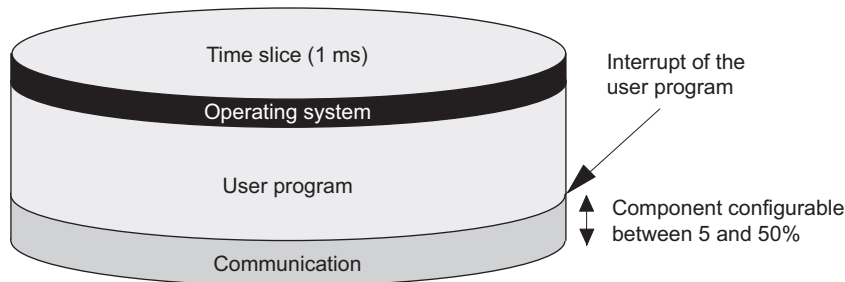

Figure 9-5 Breakdown of a time slice

Of the part remaining, the operating system of the S7-400 requires only a negligibly small amount for internal tasks.

Example: 20% communication load

You have configured a communication load of 20% in the hardware configuration.

The calculated cycle time is 10 ms.

A 20% communication load means that, on average, 200 μ s and 800 μ s of the time slice remain for communications and the user program, respectively. The CPU therefore requires $10 \text{ ms} / 800 \mu\text{s} = 13$ time slices to process one cycle. This means that the actual cycle time is 13 times a 1 ms time slice = 13 ms, if the CPU fully utilizes the configured communication load.

This means that 20% communications do not increase the cycle linearly by 2 ms but by 3 ms.

Example: 50 % communication load

You have configured a communication load of 50% in the hardware configuration.

The calculated cycle time is 10 ms.

This means that 500 μ s of each time slice remain for the cycle. The CPU therefore requires $10 \text{ ms} / 500 \mu\text{s} = 20$ time slices to process one cycle. This means that the actual cycle time is 20 ms if the CPU fully utilizes the configured communication load.

A 50% communication load means that 500 μ s of the time slice remain for communication and 500 μ s for the user program. The CPU therefore requires $10 \text{ ms} / 500 \mu\text{s} = 20$ time slices to process one cycle. This means that the actual cycle time is 20 times a 1 ms time slice = 20 ms, if the CPU fully utilizes the configured communication load.

This means that 50% communications do not increase the cycle linearly by 5 ms but by 10 ms.

Dependency of the Actual Cycle Time on the Communication Load

The following figure describes the non-linear dependency of the actual cycle time on the communication load. This example uses a cycle time of 10 ms.

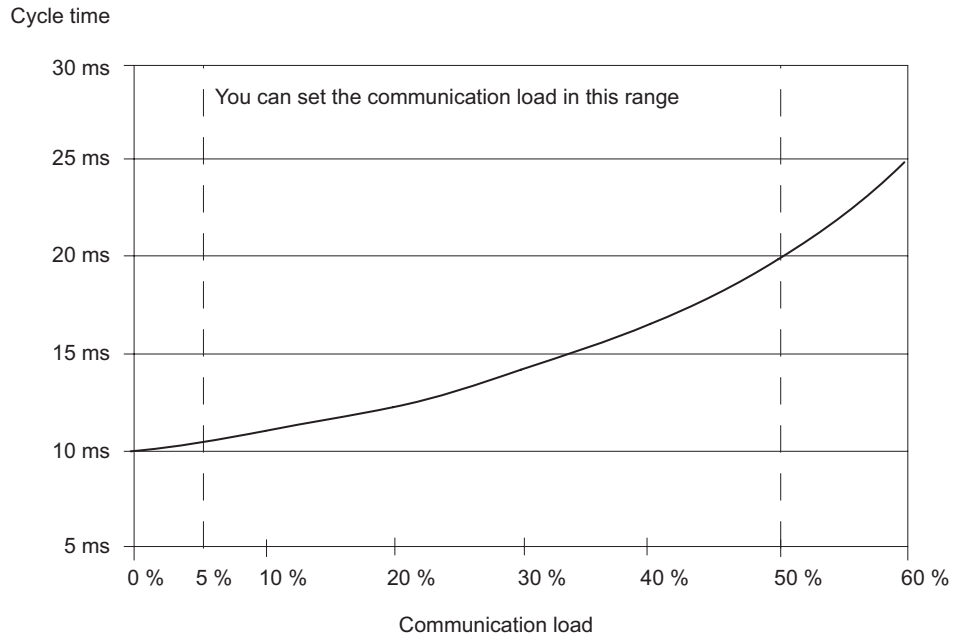

Figure 9-6 Dependency of the Cycle Time on the Communication load

Further Effect on the Actual Cycle Time

Due to the increase in the cycle time as a result of the communications component, even more asynchronous events occur, from a statistical point of view, within an OB 1 cycle than, say, interrupts. This also increases the OB 1 cycle. This extension depends on the number of events that occur per OB 1 cycle and the time required to process these events.

Notes

- Check the effects of a change of the value for the parameter "Cycle load due to communications" in system operation.
- The communication load must be taken into account when you set the maximum cycle time, since time errors will occur if it is not.

Recommendations

- If possible, apply the default value.
- Use a larger value only if the CPU is being used primarily for communication purposes and the user program is non-time-critical. In all other cases select a smaller value.

9.5 Reaction Time

Definition of the response time

The response time is the time from an input signal being detected to changing an output signal linked to it.

Variation

The actual response time is somewhere between a shortest and a longest response time. For configuring your system, you must always reckon with the longest response time.

The shortest and longest response times are analyzed below so that you can gain an impression of the variation of the response time.

Factors

The response time depends on the cycle time and on the following factors:

- Delay in the inputs and outputs
- Additional DP cycle times on the PROFIBUS DP network
- Execution of the user program

Delay in the inputs and outputs

Depending on the module, you must heed the following time delays:

- | | |
|---|---|
| • For digital inputs: | The input delay time |
| • For digital inputs with interrupt capability: | The input delay time + module-internal preparation time |
| • For digital outputs | Negligible delay times |
| • For relay outputs: | Typical delay times of 10 ms to 20 ms.
The delay of the relay outputs depends, among other things, on the temperature and the voltage. |
| • For analog inputs: | Analog input cycle time |
| • For analog outputs: | Response time of analog outputs |

The time delays can be found in the technical specifications of the signal modules.

DP cycle times on the PROFIBUS DP network

If you will have configured your PROFIBUS DP network with **STEP 7**, then **STEP 7** will calculate the typical DP cycle time that must be expected. You can then have the DP cycle time of your configuration displayed for the bus parameters on the programming device.

The following figure will provide you with an overview of the DP cycle time. We assume in this example that each DP slave has 4 bytes of data on average.

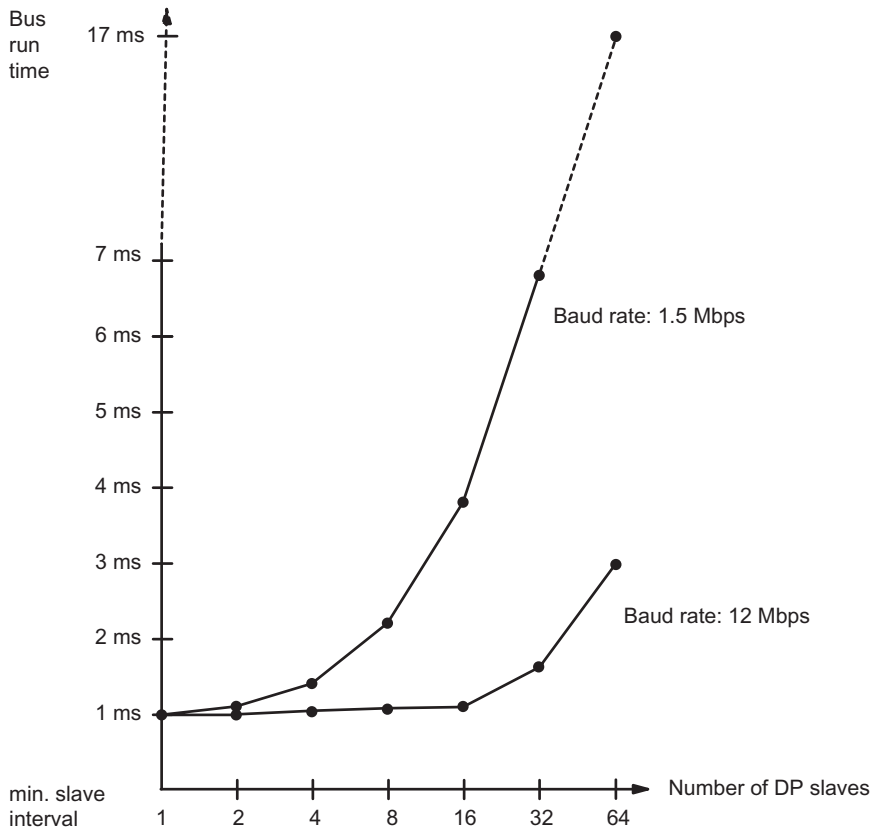

Figure 9-7 DP cycle times on the PROFIBUS DP network

With multi-master operation on a PROFIBUS DP network, you must make allowances for the DP cycle time at each master. That is, you will have to calculate the times for each master separately and then add up the results.

Update cycle in PROFINET IO

The following figure contains an overview of the duration of the update cycle in relation to the number IO devices contained in the cycle.

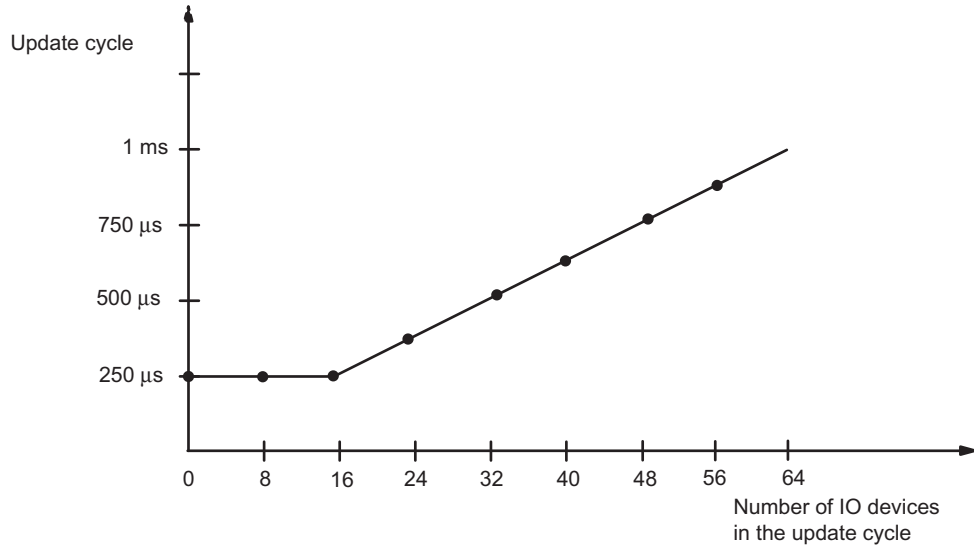

Figure 9-8 Update cycle

Shortest response time

The following figure illustrates the conditions under which the shortest response time can be achieved.

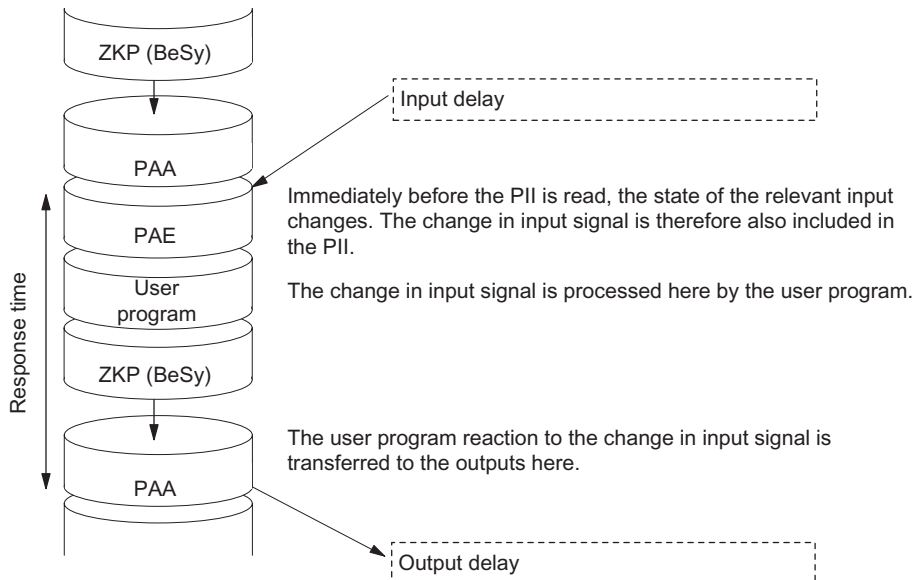

Figure 9-9 Shortest response time

Calculation

The (shortest) response time is made up as follows:

- 1 x process image transfer time for the inputs +
- 1 x process image transfer time for the outputs +
- 1 x program processing time +
- 1 x operating system processing time at the SCC +
- Delay in the inputs and outputs

The result is equivalent to the sum of the cycle time plus the I/O delay times.

Note

If the CPU and signal module are not in the central rack, you will have to add double the runtime of the DP slave frame (including processing in the DP master).

Longest response time

The following figure shows you how the longest response time results.

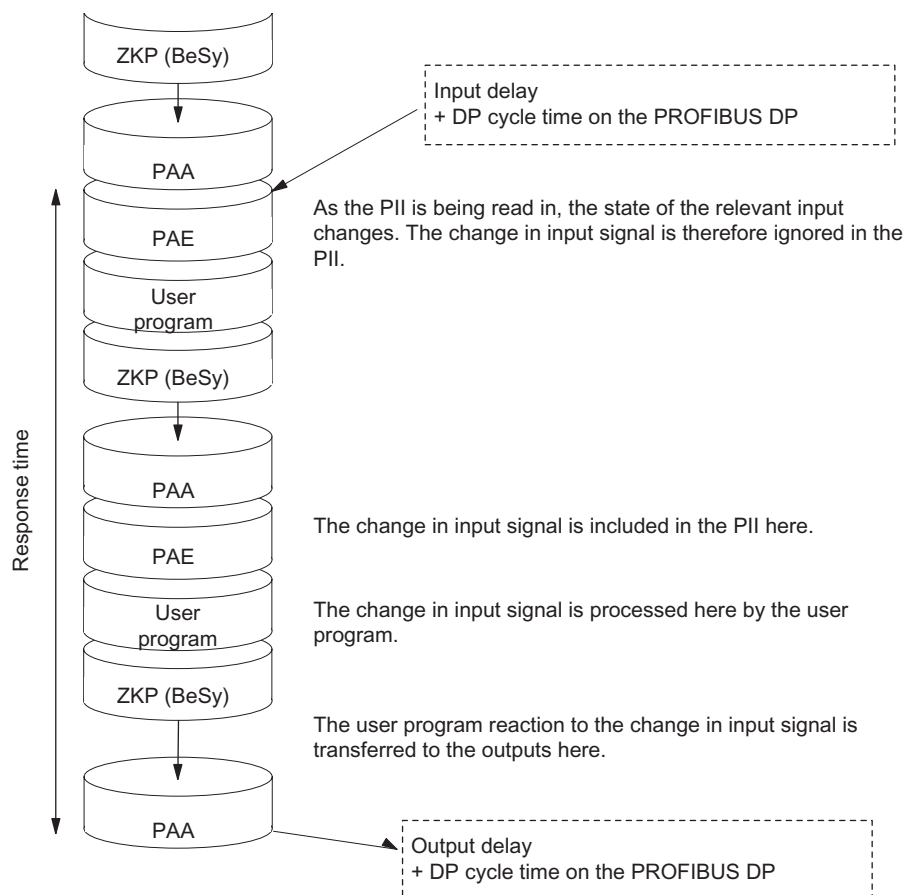

Figure 9-10 Longest response time

Calculation

The (longest) response time is made up as follows:

- 2 x process image transfer time for the inputs +
- 2 x process image transfer time for the outputs +
- 2 x operating system processing time +
- 2 x program processing time +
- 2 x runtime of the DP slave frame (including processing in the DP master) +
- Delay in the inputs and outputs

This is equivalent to the sum of twice the cycle time and the delay in the inputs and outputs plus twice the DP cycle time.

I/O Direct accesses

You achieve quicker response times by direct accesses to the I/O in the user program. For example, you can partly bypass the response times as described above using one of the following commands:

- L PIB
- T PQW

Reducing the response time

In this way the maximum response time is reduced to the following components:

- Delay in the inputs and outputs
- Runtime of the user program (can be interrupted by high-priority interrupt handling)
- Runtime of direct accesses
- Twice the bus transit time of DP

The following table lists the execution times of direct accesses by the CPU to I/O modules. The times shown are "ideal values".

Table 9- 6 Reducing the response time

Access mode	CPU 412	CPU 414	CPU 416	CPU 417
I/O module				
Read byte	3.1 µs	2.6 µs	2.5 µs	2.1 µs
Read word	4.7 µs	4.2 µs	4.0 µs	3.8 µs
Read double word	7.8µs	7.2 µs	7.1 µs	6.9 µs
Write byte	2.8 µs	2.3 µs	2.2 µs	2.0 µs
Write word	4.2 µs	3.6 µs	3.4 µs	3.1 µs
Write double word	6.7 µs	6.2 µs	5.9 µs	5.6 µs

9.5 Reaction Time

Access mode	CPU 412	CPU 414	CPU 416	CPU 417
Expansion rack with local connection				
Read byte	6.4 µs	6.0 µs	5.7 µs	5.0 µs
Read word	11.6 µs	11.0 µs	10.8 µs	10.6 µs
Read double word	21.5 µs	21.0 µs	20.8 µs	20.6 µs
Write byte	5.9 µs	5.4 µs	5.4 µs	5.0 µs
Write word	10.7 µs	10.1 µs	10.0 µs	9.7 µs
Write double word	19.8 µs	19.5 µs	19.4 µs	19.1 µs
Read byte in the expansion rack with remote connection				
Read byte	11.3 µs	11.3 µs	11.3 µs	11.2 µs
Read word	22.9 µs	22.8 µs	22.8 µs	22.9 µs
Read double word	46.0 µs	45.9 µs	45.9 µs	45.8 µs
Write byte	10.8 µs	10.8 µs	10.8 µs	10.9 µs
Write word	22.0 µs	21.9 µs	21.9 µs	21.9 µs
Write double word	44.1 µs	44.0 µs	44.0 µs	44.1 µs

The specified times are merely CPU processing times and apply, unless otherwise stated, to signal modules in the central rack.

Note

You can similarly achieve fast response times by using hardware interrupts; refer to the section on the interrupt response time.

9.6 Calculating cycle and reaction times

Cycle Time

1. Using the instruction list, determine the runtime of the user program.
2. Calculate and add the transfer time for the process image. You will find approximate values in table 9.3 "Portions of the process image transfer time".
3. Add to it the processing time at the scan cycle checkpoint. You will find approximate values in table 9.4 "Operating system processing time at the scan cycle checkpoint".

The result you achieve is the **cycle time**.

Increasing the Cycle Time with Communication and Interrupts

1. The next step is to multiply the result by the following factor:

$$\frac{100}{100 - \text{"configured communication load in \%\"}}$$

2. Using the Instruction List, calculate the runtime of the program sections that hardware interrupts. Add to it the relevant value from table 9.5 "Increase in cycle time by nesting interrupts".

Multiply this value by the factor from step 1.

Add this value to the theoretical cycle time as often as the interrupt is triggered or is expected to be triggered during the cycle time.

The result you obtain is approximately the **actual cycle time**. Make a note of the result.

Table 9- 7 Example of Calculating the Response Time

Shortest response time	Longest response time
3. Then, calculate the delays in the inputs and outputs and, if applicable, the DP cycle times on the PROFIBUS DP network.	3. Multiply the actual cycle time by a factor of 2.
	4. Then, calculate the delays in the inputs and outputs and the DP cycle times on the PROFIBUS DP network.
4. The result you obtain is the shortest response time .	5. The result you obtain is the longest response time .

9.7 Examples of Calculating the Cycle Time and Reaction Time

Example I

You will have installed an S7-400 with the following modules in the central rack:

- One CPU 414-2
- 2 digital input modules SM 421; DI 32xDC 24 V (4 bytes each in the PI)
- 2 digital output modules SM 422; DO 32xDC 24 V/0.5A (4 bytes each in the PI)

User Program

According to the Instruction List, your user program has a runtime of 12 ms.

Cycle Time Calculation

The cycle time for the example results from the following times:

- Process image transfer time
Process image: $7 \mu\text{s} + 16 \text{ bytes} \times 1.8 \mu\text{s} = \text{approx. } 0.036 \text{ ms}$
- Operating system runtime at scan cycle checkpoint:
approx. **0.17 ms**

The cycle time for the example results from the sum of the times listed:

Cycle time = 12.00 ms + 0.036 ms + 0.17 ms = **12.206 ms**.

Calculation of the Actual Cycle Time

- Allowance of communication load (default value: 20 %):
 $12.21 \text{ ms} \times 100 / (100-20) = \mathbf{15.257 \text{ ms}}$.
- There is no interrupt handling.

The actual rounded cycle time is therefore **15.3 ms**.

Calculation of the Longest Response Time

- Longest response time
 $15.3 \text{ ms} \times 2 = \mathbf{30.6 \text{ ms}}$.
- The delay in the inputs and outputs is negligible.
- All the components are plugged into the central rack; DP cycle times do not therefore have to be taken into account.
- There is no interrupt handling.

The longest rounded response time is therefore **31 ms**.

Example II

You will have installed an S7-400 with the following modules:

- One CPU 414-2
- 4 digital input modules SM 421; DI 32xDC 24 V (4 bytes each in the PI)
- 3 digital output modules SM 422; DO 16xDC 24 V/2A (2 bytes each in the PI)
- 2 analog input modules SM 431; AI 8x13Bit (not in PI)
- 2 analog output modules SM 432; AO 8x13Bit (not in PI)

CPU Parameters

The CPU has been assigned parameters as follows:

- Cycle load due to communications: 40 %

User Program

According to the Instruction List, the user program has a runtime of 10.0 ms.

Cycle Time Calculation

The theoretical cycle time for the example results from the following times:

- Process image transfer time
Process image: $7 \mu\text{s} + 22 \text{ bytes} \times 1.5 \mu\text{s} = \text{approx. } 0.047 \text{ ms}$
- Operating system runtime at scan cycle checkpoint:
approx. **0.17 ms**

The cycle time for the example results from the sum of the times listed:

Cycle time = 10.0 ms + 0.047 ms + 0.17 ms = **10.22 ms.**

Calculation of the Actual Cycle Time

- Allowance of communication load:
 $10.22 \text{ ms} \times 100 / (100-40) = 17.0 \text{ ms.}$
Every 100 ms, a time-of-day interrupt is triggered with a runtime of 0.5 ms.
The interrupt can be triggered a maximum of once during a cycle:
 $0.5 \text{ ms} + 0,24 \text{ ms (from table " Increase in cycle time by nesting interrupts")} = 0.74 \text{ ms.}$
Allowance for communication load:
 $0.74 \text{ ms} \times 100 / (100-40) = 1.23 \text{ ms.}$
- $17.0 \text{ ms} + 1.23 \text{ ms} = 18.23 \text{ ms.}$

The actual cycle time is therefore **18.23 ms** taking into account the time slices.

Calculation of the Longest Response Time

- Longest response time
 $18.23 \text{ ms} * 2 = \mathbf{36.5 \text{ ms}}$.
- Delays in the inputs and outputs
 - The digital input module SM 421; DI 32xDC 24 V has an input delay of not more than **4.8 ms** per channel
 - The digital output module SM 422; DO 16xDC 24 V/2A has a negligible output delay.
 - The analog input module SM 431; AI 8x13Bit was assigned parameters for 50 Hz interference frequency suppression. This results in a conversion time of 25 ms per channel. Since 8 channels are active, a cycle time of **200 ms** results for the analog input module.
 - The analog output module SM 432; AO 8x13-bit was programmed for the measuring range of 0 to 10V. This results in a conversion time of 0.3 ms per channel. Since 8 channels are active, a cycle time of 2.4 ms results. The settling time for the resistive load of 0.1 ms must still be added. The result is a response time of **2.5 ms** for an analog output.
- All the components are plugged into the central rack; DP cycle times do not therefore have to be taken into account.
- Case 1: When a digital signal is read in, an output channel of the digital output module is set. This produces a response time of:
Response time = 36.5 ms + 4.8 ms = **41.3 ms**.
- Case 2: An analog value is read in and an analog value output. This produces a response time of:
Response time = 36.5 ms + 200 ms + 2.5 ms = **239.0 ms**.

9.8 Interrupt Reaction Time

Definition of the Interrupt Response Time

The interrupt response time is the time from when an interrupt signal first occurs to calling the first instruction in the interrupt OB.

General rule: Interrupts having a higher priority take precedence. This means that the interrupt response time is increased by the program processing time of the higher priority interrupt OBs and interrupt OBs with the same priority that have not yet been processed (queue).

Note

Read and write jobs with the maximum amount of data (approx. 460 bytes), interrupt response times can be delayed.

When interrupts are transferred between a CPU and DP master, only a diagnostic or hardware interrupt can be currently reported at any time from a DP chain.

Calculation

Table 9- 8 Calculating the Interrupt Response Time

Minimum interrupt response time of the CPU + minimum interrupt response time of the signal modules + DP cycle time on PROFIBUS-DP <hr/> = Shortest response time	Maximum interrupt response time of the CPU + maximum interrupt response time of the signal modules + 2 * DP cycle time on PROFIBUS-DP <hr/> = Longest response time
---	--

Hardware Interrupt and Diagnostic Interrupt Response Times of CPUs

Table 9- 9 Hardware Interrupt and Diagnostic Interrupt Response Times; Maximum Interrupt Response Time Without Communication

CPU	Process interrupt response times		Diagnostic interrupt response times		Asynchronous error (OB 85 in process image update)
	Min.	Max.	Min.	Max.	
412	339 µs	363 µs	342 µs	362 µs	209 µs
414	205 µs	218 µs	204 µs	238 µs	164 µs
416	139 µs	147 µs	138 µs	145 µs	107 µs
417	89 µs	102 µs	90 µs	102 µs	51 µs

Increasing the maximum interrupt response time with communication

The maximum interrupt response time is longer when the communication functions are active. The increase is calculated with the following equation:

$$\text{CPU 412: } t_v = 100 \mu\text{s} + 1000 \mu\text{s} \times n\%$$

$$\text{CPU 414-417: } t_v = 100 \mu\text{s} + 1000 \mu\text{s} \times n\%$$

where n = cycle load from communication

Signal Modules

The hardware interrupt response time of the signal modules is made up as follows:

- Digital input modules:

Hardware interrupt response time = internal interrupt processing time + input delay

You will find the times in the data sheet of the digital input module concerned.

- Analog input modules:

Hardware interrupt response time = internal interrupt processing time + conversion time

The internal interrupt processing time of the analog input modules is negligible. The conversion times can be taken from the data sheet of the analog input module concerned.

The diagnostic interrupt response time of the signal modules is the time which elapses between a diagnostics event being detected by the signal module and the diagnostic interrupt being triggered by the signal module. This time is so small that it can be ignored.

Hardware Interrupt Processing

When the hardware interrupt OB 40 is called, the hardware interrupt is processed. Interrupts with higher priority interrupt hardware interrupt processing, and direct access to the I/O is made when the instruction is executed. When hardware interrupt processing is completed, either cyclic program processing is continued or other interrupt OBs with the same or a lower priority are called and processed.

9.9 Example: Calculating the Interrupt Reaction Time

Parts of the Interrupt Response Time

As a reminder: The hardware interrupt response time comprises the following:

- Hardware interrupt response time of the CPU
- Hardware interrupt response time of the signal module.
- 2 x DP cycle time on PROFIBUS-DP

Example: You will have an S7-400 consisting of a CPU 416-2 and 4 digital modules in the central rack. One digital input module is the SM 421; DI 16xUC 24/60 V; with hardware and diagnostic interrupts. In the parameter assignment of the CPU and the SM, you will have only enabled the hardware interrupt. You do not require time-driven processing, diagnostics and error handling. You will have set an input delay of 0.5 ms for the digital input module. No activities are necessary at the cycle checkpoint. You will have set a cycle load caused by communication of 20%.

Calculation

The hardware interrupt response time for the example results from the following times:

- Hardware interrupt response time of the CPU 416-2: Approx. 0.147 ms
- Extension by communication according to the equation in the table "Hardware interrupt and diagnostic interrupt response times; maximum interrupt response time without communication":

$$100 \mu\text{s} + 1000 \mu\text{s} \times 20 \% = 300 \mu\text{s} = 0.3 \text{ ms}$$

- Hardware interrupt response time of the SM 421; DI 16xUC 24/60 V:
 - Internal interrupt processing time: 0.5 ms
 - Input delay: 0.5 ms
- Since the signal modules are plugged into the central rack, the DP cycle time on the PROFIBUS-DP is not relevant.

The hardware interrupt response time results from the sum of the listed times:

$$\text{Hardware interrupt response time} = 0.147 \text{ ms} + 0.3 \text{ ms} + 0.5 \text{ ms} + 0.5 \text{ ms} = \text{approx. } \mathbf{1.45 \text{ ms.}}$$

This calculated hardware interrupt response time is the time from a signal being applied across the digital input to the first instruction in OB 40.

9.10 Reproducibility of Time-Delay and Watchdog Interrupts

Definition of "Reproducibility"

Time-delay interrupt:

The deviation with time from the first instruction of the interrupt OB being called to the programmed interrupt time.

Watchdog interrupt:

The variation in the time interval between two successive calls, measures between the first instruction of the interrupt OB in each case.

Reproducibility

The following table contains the reproducibility of time-delay and cyclic interrupts of the CPUs.

Table 9- 10 Reproducibility of Time-Delay and Watchdog Interrupts of the CPUs.

Module	Reproducibility	
	Time delay interrupt:	Cyclic interrupt
CPU 412	-195 µs / +190 µs	-50 µs / +48 µs
CPU 414	-182 µs / +185 µs	-25 µs / +26 µs
CPU 416	-210 µs / +206 µs	-16 µs / +18 µs
CPU 417	-157 µs / +155 µs	-12 µs / +13 µs

These times only apply if the interrupt can actually be executed at this time and if not interrupted, for example, by higher-priority interrupts or queued interrupts of equal priority.

9.11 CBA response times

Definition of the Response Time

The response time is the time that it takes a value from the user program of a CPU to reach the user program of a second CPU. This assumes that no time is lost in the user program itself.

Response Time for Cyclic Interconnection

The response time of an interconnection in an S7-400 CPU is composed of the following portions:

- Processing time on the transmitting CPU
- The transmission frequency configured in SIMATIC iMap (fast, medium or slow)
- Processing time on the receiving CPU

You have specified a value for the transmission frequency suited to your plant during the configuration with SIMATIC iMap. Faster or slower response times can occur because the data transmission to the user program is performed asynchronously. Therefore, check the achievable response time during commissioning and change the configuration as required.

Measurements for Cyclic Interconnections in an Example Configuration

To be able to estimate the achievable CBA response time better, consider the following measurements.

The processing times on the transmitting CPU and the receiving CPU basically depend on the sum of the input and output interconnections and the amount of data on them. The following figure shows this relationship using two examples for transmitting 600 bytes and 9600 bytes to a varying number of interconnections:

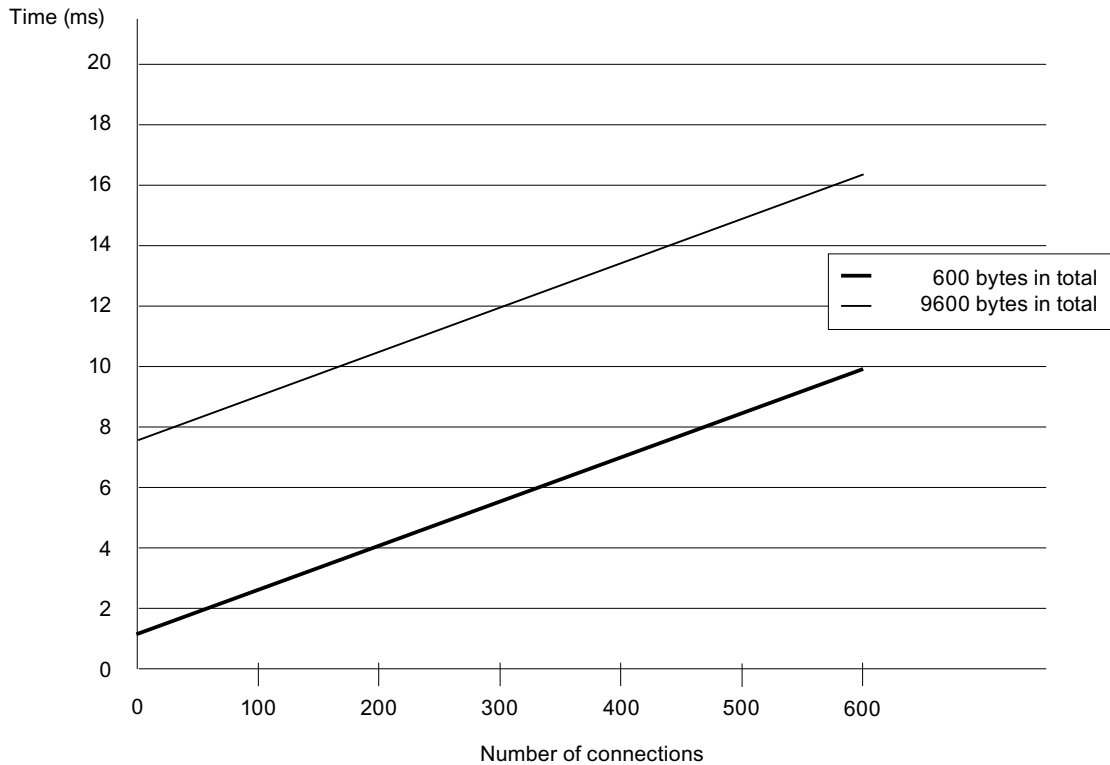

Figure 9-11 Processing time for sending and receiving

You can estimate the CBA response time using the information in this figure and the time you have set for the transmission frequency.

The following applies:

CBA response times =
Processing time on the transmitting CPU* +
Cycle time based on the configured transmission frequency** +
Processing time on the receiving CPU*

*) Add all input and output interconnections of the CPU to determine the processing time. You can read the processing time from the diagram based on the determined number of interconnections and amount of data on them.

***) The configured transmission frequency has a direct relationship to the actual cycle time in the network. For technical reasons, the cycle time is based on the square of the base cycle time of 1ms. The actual cycle time therefore corresponds to the next smaller square of the configured transmission frequency; the following relationships result from the specified values: (transmission frequency <-> cycle time): 1<->1 | 2<->2 | 5<->4 | 10<->8 | 20<->16 | 50<->32 | 100<->64 | 200<->128 | 500<->256 | 1000<->512

Note**Using iMap as of V3.0 SP1**

In iMap as of V3.0 SP1 there are only squares of the base cycle time of 1ms for cyclic interconnections. The preceding footnote **) then no longer applies.

Note on the Processing Times for Cyclic Interconnections

- The processing times are based on 32 remote partners. Few remote partners reduces the processing times by approx. 0.02 ms per partner.
- The processing times are based on byte interconnections (single bytes or arrays).
- The processing times are applicable for situations in which the same transmission frequency is configured for all cyclic interconnections. Increased transmission frequency can improve the performance.
- When acyclic interconnections with the maximum amount of data are simultaneously active, the response times of the cyclic interconnections increase by approx. 33%.
- The example measurements were performed with a CPU 416-3 PN/DP. With a CPU 414-3 PN/DP the processing times increase by up to approx. 20%.

Response Time for Acyclic Interconnections

The resulting response time depends on the configured sampling frequency and the number of cyclic interconnections that are simultaneously active. You can see three examples for the resulting response times in the following table.

Table 9- 11 Response time for acyclic interconnections

Configured sampling frequency	Resulting response time without cyclic interconnections	Resulting response time with cyclic interconnections (maximum amount of data)
200 ms	195 ms	700 ms
500 ms	480 ms	800 ms
1000 ms	950 ms	1050 ms

General Information about Achievable CBA Response Times

- The CBA response time increases if the CPU is performing additional tasks, such as programmed block communication or S7 connections.
- If you frequently call SFCs "PN_IN", "PN_OUT" or "PN_DP", you increase the CBA processing times and therefore increase CBA response time.
- A very small OB1 cycle increases the CBA response time when the PN interface is updated automatically (at the cycle control point).

Technical specifications

10.1 Specifications of the CPU 412-1 (6ES7412-1XJ05-0AB0)

Data

CPU and firmware version	
MLFB	6ES7412-1XJ05-0AB0
• Firmware version	V 5.3
Associated programming package	as of STEP 7 V 5.3 SP2 + hardware update See also Introduction (Page 11)
Memory	
Work memory	
• Integrated	144 KB for code 144 KB for data
Load memory	
• Integrated	512 KB RAM
• Expandable FEPR0M	With memory card (FLASH) up to 64 MB
• Expandable RAM	With memory card (RAM) up to 64 MB
Backup with battery	Yes, all data
Typical processing times	
Processing times of	
• Bit operations	75 ns
• Word operations	75 ns
• Fixed-point arithmetic	75 ns
• Floating-point arithmetic	225 ns
Timers/counters and their retentivity	
S7 counters	2048
• Retentivity programmable	From C 0 to C 2047
• Default	From C 0 to C 7
• Counting range	0 to 999
IEC counters	Yes
• Type	SFB
S7 timers	2048
• Retentivity programmable	From T 0 to T 2047
• Default	No retentive timers
• Time range	10 ms to 9990 s

10.1 Specifications of the CPU 412-1 (6ES7412-1XJ05-0AB0)

IEC timers	Yes
• Type	SFB
Data areas and their retentivity	
Total retentive data area (including bit memories, timers, counters)	Total work and load memory (with backup battery)
Bit memory	4 KB
• Retentivity programmable	From MB 0 to MB 4095
• Default retentive address areas	From MB 0 to MB 15
Clock flag bits	8 (1 flag byte)
Data blocks	Maximum 1500 (DB 0 reserved) Band of numbers 1 - 16000
• Size	Maximum 64 KB
Local data (programmable)	Maximum 8 KB
• Default	4 KB
Blocks	
OBs	See <i>Instruction List</i>
• Size	Maximum 64 KB
Nesting depth	
• Per priority class	24
• Additionally within an error OB	1
FBs	Maximum 750 Band of numbers 0 - 7999
• Size	Maximum 64 KB
FCs	Maximum 750 Band of numbers 0 - 7999
• Size	Maximum 64 KB
SDBs	Maximum 2048
Address areas (I/O)	
Total I/O address area	4 KB / 4 KB including diagnostics addresses, addresses for I/O interface modules, etc
Distributed of this	
• MPI/DP interface	2 KB / 2 KB
Process image	4 KB/4 KB (programmable)
• Default	128 bytes / 128 bytes
• Number of process image partitions	Maximum 15
Consistent data	Maximum 244 bytes
Digital channels	Maximum 32768 / maximum 32768
• Of those are central	Maximum 32768 / maximum 32768
Analog channels	Maximum 2048 / maximum 2048
• Of those are central	Maximum 2048 / maximum 2048

10.1 Specifications of the CPU 412-1 (6ES7412-1XJ05-0AB0)

Configuration	
Central racks/expansion units	Maximum 1/21
Multicomputing	Maximum 4 CPUs with UR1 or UR2 maximum 2 CPUs with CR3
Number of plug-in IMs (total)	Maximum 6
<ul style="list-style-type: none"> • IM 460 	Maximum 6
<ul style="list-style-type: none"> • IM 463-2 	Maximum 4
Number of DP masters	
<ul style="list-style-type: none"> • Integrated 	1
<ul style="list-style-type: none"> • Via IM 467 	Maximum 4
<ul style="list-style-type: none"> • Via CP 443-5 Extended 	Maximum 10
IM 467 cannot be used with the CP 443-5 Extended	
IM 467 cannot be used together with the CP 443-1 EX4x in PN IO mode	
Number of PN IO controllers	
<ul style="list-style-type: none"> • Via CP 443-1 in PN IO mode 	Maximum 4 in central rack, see manual for CP 443-1, no combined operation of CP 443-1 EX40 and CP443-1EX41/EX20/GX20
Number of plug-in S5 modules via adapter casing (in the central rack)	Maximum 6
Operable function modules and communication processors	
<ul style="list-style-type: none"> • FM 	Limited by the number of slots and the number of connections
<ul style="list-style-type: none"> • CP 440 	Limited by the number of slots
<ul style="list-style-type: none"> • CP 441 	Limited by the number of connections
<ul style="list-style-type: none"> • PROFIBUS and Ethernet CPs including CP 443-5 Extended and IM 467 	Maximum 14 No more than 10 of which may be CPs or IMs as DP master, up to 4 PN IO controllers
Time	
Clock	Yes
<ul style="list-style-type: none"> • Buffered 	Yes
<ul style="list-style-type: none"> • Resolution 	1 ms
<ul style="list-style-type: none"> • Accuracy after POWER OFF 	Maximum deviation per day 1.7 s
<ul style="list-style-type: none"> • Accuracy after POWER ON 	Maximum deviation per day 8.6 s
Operating hours counter	16
<ul style="list-style-type: none"> • Number 	0 to 15
<ul style="list-style-type: none"> • Value range 	0 to 32767 hours 0 to 2 ³¹ -1 hours when SFC 101 is used
<ul style="list-style-type: none"> • Granularity 	1 hour
<ul style="list-style-type: none"> • Retentive 	Yes
Time synchronization	Yes
<ul style="list-style-type: none"> • In PLC, on MPI and DP 	As master or slave

10.1 Specifications of the CPU 412-1 (6ES7412-1XJ05-0AB0)

Time difference in the system with synchronization via MPI	Maximum 200 ms
S7 message functions	
Number of stations that can log on for message functions (e.g. WIN CC or SIMATIC OP)	Maximum 8 with ALARM_8 or ALARM_P (WinCC); up to 31 with ALARM_S or ALARM_D (OPs)
Symbol-related messages	Yes
<ul style="list-style-type: none"> Number of messages Total 100 ms interval 500 ms interval 1000 ms interval 	Maximum 512 None Maximum 256 Maximum 256
<ul style="list-style-type: none"> Number of auxiliary values per message With 100 ms interval With 500, 1000 ms interval 	None 1
Block-related messages	Yes
<ul style="list-style-type: none"> Simultaneously active ALARM_S/SQ blocks and ALARM_D/DQ blocks 	Maximum 250
ALARM_8 blocks	Yes
<ul style="list-style-type: none"> Number of communication jobs for ALARM_8 blocks and blocks for S7 communication (programmable) 	Maximum 300
<ul style="list-style-type: none"> Default 	150
Process control messages	Yes
Number of archives that can log on simultaneously (SFB 37 AR_SEND)	4
Test and startup functions	
Status/modify variable	Yes, maximum 16 variable tables
<ul style="list-style-type: none"> Variable 	Inputs/outputs, bit memories, DB, distributed inputs/outputs, timers, counters
<ul style="list-style-type: none"> Number of variables 	Maximum 70
Force	Yes
<ul style="list-style-type: none"> Variable 	Inputs/outputs, bit memories, distributed inputs/outputs
<ul style="list-style-type: none"> Number of variables 	Maximum 64
Status block	Yes, maximum 2 blocks at the same time
Single-step	Yes
Number of breakpoints	4
Diagnostic buffer	Yes
<ul style="list-style-type: none"> Number of entries 	Maximum 200 (programmable)
<ul style="list-style-type: none"> Default 	120
Cyclic interrupts	
Value range	500 µs to 60000 ms

10.1 Specifications of the CPU 412-1 (6ES7412-1XJ05-0AB0)

Communication	
PG/OP communication	Yes
Number of connectable OPs	31
Number of connection resources for S7 connections via all interfaces and CPs	32, with one each of those reserved for programming device and OP
Global data communication	Yes
• Number of GD circuits	Maximum 8
• Number of GD packets Sender Receiver	Maximum 8 Maximum 16
• Size of GD packets Consistent of this	Maximum 54 bytes 1 variable
S7 basic communication	Yes
• MPI Mode	Via SFC X_SEND, X_RCV, X_GET and X_PUT
• DP Master Mode	Via SFC I_GET and I_PUT
• User data per job Consistent of this	Maximum 76 bytes 1 variable
S7 communication	Yes
• User data per job Consistent of this	Maximum 64 KB 1 variable (462 bytes)
S5-compatible communication	Via FC AG_SEND and AG_RECV, max. via 10 CP 443-1 or 443-5)
• User data per job Consistent of this	Maximum 8 KB 240 bytes
• Number of simultaneous AG-SEND/AG-RECV jobs per CPU, maximum	24/24
Standard communication (FMS)	Yes (via CP and loadable FBs)
Open IE communication	ISO on TCP via CP 443-1 and downloadable FBs
• Maximum data length	1452 bytes
Interfaces	
1st interface	
Type of interface	Integrated
Features	RS 485 / PROFIBUS
Electrically isolated	Yes
Power supply to interface 24 V rated voltage (15 to 30 VDC)	Maximum 150 mA
Number of connection resources	MPI: 32 DP: 16
Functionality	
• MPI	Yes
• PROFIBUS DP	DP master/DP slave

10.1 Specifications of the CPU 412-1 (6ES7412-1XJ05-0AB0)

1st interface MPI mode	
Services	
PG/OP communication	Yes
Routing	Yes
Global data communication	Yes
S7 basic communication	Yes
S7 communication	Yes
Time synchronization	Yes
Transmission rates	Up to 12 Mbps
1st interface DP master mode	
Services	
PG/OP communication	Yes
Routing	Yes
S7 basic communication	Yes
S7 communication	Yes
Constant cycle	Yes
SYNC/FREEZE	Yes
Activate/deactivate DP slaves	Yes
Time synchronization	Yes
Direct data communication (internetwork traffic)	Yes
Transmission rates	Up to 12 Mbps
Number of DP slaves	Maximum 32
Number of slots per interface	Maximum 544
Address area	Maximum 2 KB inputs / 2 KB outputs
User data per DP slave	Maximum 244 bytes maximum 244 bytes I and maximum 244 bytes O, maximum 244 slots maximum 128 bytes per slot
Note:	
<ul style="list-style-type: none"> • The total sum of the input bytes across all slots may not exceed 244. • The total sum of the output bytes across all slots may not exceed 244. • The address range of the interface (maximum 2 KB inputs / 2 KB outputs) must not be exceeded in total across all 32 slaves. 	
1st interface DP slave mode	
Service	
Status/modify	Yes
Programming	Yes
Routing	Yes
Time synchronization	Yes
GSD file (http://support.automation.siemens.com/WW/view/en/113652)	
Transmission rate	Up to 12 Mbps
Transfer memory	244 bytes inputs / 244 bytes outputs
Virtual slots	Maximum 32
User data per address area	Maximum 32 bytes
Consistent of this	32 bytes

10.1 Specifications of the CPU 412-1 (6ES7412-1XJ05-0AB0)

Programming	
Programming language	LAD, FBD, STL, SCL, S7 GRAPH, S7 HiGraph
Instruction set	See <i>Instruction List</i>
Nesting levels	7
System functions (SFC)	See <i>Instruction List</i>
Number of simultaneously active SFCs per segment	
• SFC 11 "DPSYC_FR"	2
• SFC 12 "D_ACT_DP"	8
• SFC 59 "RD_REC"	8
• SFC 58 "WR_REC"	8
• SFC 55 "WR_PARM"	8
• SFC 57 "PARM_MOD"	1
• SFC 56 "WR_DPARM"	2
• SFC 13 "DPNRM_DG"	8
• SFC 51 "RDSYSST"	1 ... 8
• SFC 103 "DP_TOPOL"	1
System function blocks (SFB)	See <i>Instruction List</i>
Number of simultaneously active SFBs	
• SFB 52 "RDREC"	8
• SFB 53 "WRREC"	8
User program protection	Password protection
Access to consistent data in the process image	Yes
Isochronous mode	
User data per isochronous slave	Maximum 244 bytes
Maximum number of bytes and slaves in a process image partition	The following must apply: Number of bytes/100 + number of slaves < 16
Constant bus cycle time	Yes
Shortest clock pulse	1.5 ms 0.5 ms without use of SFC 126, 127
Longest clock pulse	32 ms
See <i>Isochronous Mode</i> manual	
CiR synchronization time	
Base load	100 ms
Time per I/O byte	30 µs
Dimensions	
Mounting dimensions WxHxD (mm)	25x290x219
Slots required	1
Weight	Approx. 0.7 kg

10.1 Specifications of the CPU 412-1 (6ES7412-1XJ05-0AB0)

Voltages, currents	
Current consumption from the S7-400 bus (5 VDC)	Typically 0.5 A Maximum 0.6 A
Current consumption from S7-400 bus (24 VDC) The CPU does not consume any current at 24 V, it only makes this voltage available at the MPI/DP interface.	Total current consumption of the components connected to the MPI/DP interfaces, with a maximum of 150 mA per interface
Backup current	Typically 125 µA (up to 40° C) Maximum 550 µA
Maximum backup time	See <i>Module Specifications</i> reference manual, Section 3.3.
Supply of external backup voltage to CPU	5 to 15 VDC
Power loss	Typically 2.5 W

10.2 Specifications of the CPU 412-2 (6ES7412-2XJ05-0AB0)

Data

CPU and firmware version	
MLFB	6ES7412-2XJ05-0AB0
• Firmware version	V 5.3
Associated programming package	as of STEP 7 V 5.3 SP2 + hardware update see also Introduction (Page 11)
Memory	
Work memory	
• Integrated	256 KB for code 256 KB for data
Load memory	
• Integrated	512 KB RAM
• Expandable FEPR0M	With memory card (FLASH) up to 64 MB
• Expandable RAM	With memory card (RAM) up to 64 MB
Buffering	Yes
• With battery	All data
• Without battery	None
Typical processing times	
Processing times of	
• Bit operations	75 ns
• Word operations	75 ns
• Fixed-point arithmetic	75 ns
• Floating-point arithmetic	225 ns
Timers/counters and their retentivity	
S7 counters	2048
• Retentivity programmable	From C 0 to C 2047
• Default	From C 0 to C 7
• Counting range	0 to 999
IEC counters	Yes
• Type	SFB
S7 timers	2048
• Retentivity programmable	From T 0 to T 2047
• Default	No retentive timers
• Time range	10 ms to 9990 s
IEC timers	Yes
• Type	SFB

10.2 Specifications of the CPU 412-2 (6ES7412-2XJ05-0AB0)

Data areas and their retentivity	
Total retentive data area (including bit memories, timers, counters)	Total work and load memory (with backup battery)
Bit memory	4 KB
<ul style="list-style-type: none"> Retentivity programmable 	From MB 0 to MB 4095
<ul style="list-style-type: none"> Default retentive address areas 	From MB 0 to MB 15
Clock flag bits	8 (1 flag byte)
Data blocks	Maximum 3000 (DB 0 reserved) Band of numbers 1 - 16000
<ul style="list-style-type: none"> Size 	Maximum 64 KB
Local data (programmable)	Maximum 8 KB
<ul style="list-style-type: none"> Default 	4 KB
Blocks	
OBs	See <i>Instruction List</i>
<ul style="list-style-type: none"> Size 	Maximum 64 KB
Nesting depth	
<ul style="list-style-type: none"> Per priority class 	24
<ul style="list-style-type: none"> Additionally within an error OB 	1
FBs	Maximum 1500 Band of numbers 0 - 7999
<ul style="list-style-type: none"> Size 	Maximum 64 KB
FCs	Maximum 1500 Band of numbers 0 - 7999
<ul style="list-style-type: none"> Size 	Maximum 64 KB
SDBs	Maximum 2048
Address areas (I/O)	
Total I/O address area	4 KB / 4 KB including diagnostics addresses, addresses for I/O interface modules, etc
Distributed of this	
<ul style="list-style-type: none"> MPI/DP interface 	2 KB / 2 KB
<ul style="list-style-type: none"> DP interface 	4 KB / 4 KB
Process image	4 KB/4 KB (programmable)
<ul style="list-style-type: none"> Default 	128 bytes / 128 bytes
<ul style="list-style-type: none"> Number of process image partitions 	Maximum 15
Consistent data	Maximum 244 bytes
Digital channels	Maximum 32768 / maximum 32768
<ul style="list-style-type: none"> Of those are central 	Maximum 32768 / maximum 32768
Analog channels	Maximum 2048 / maximum 2048
<ul style="list-style-type: none"> Of those are central 	Maximum 2048 / maximum 2048

10.2 Specifications of the CPU 412-2 (6ES7412-2XJ05-0AB0)

Configuration	
Central racks/expansion units	Maximum 1/21
Multicomputing	Maximum 4 CPUs with UR1 or UR2 Maximum 2 CPUs with CR3
Number of plug-in IMs (total)	Maximum 6
<ul style="list-style-type: none"> • IM 460 	Maximum 6
<ul style="list-style-type: none"> • IM 463-2 	Maximum 4
Number of DP masters	
<ul style="list-style-type: none"> • Integrated 	2
<ul style="list-style-type: none"> • Via IM 467 	Maximum 4
<ul style="list-style-type: none"> • Via CP 443-5 Extended 	Maximum 10
IM 467 cannot be used with the CP 443-5 Extended	
IM 467 cannot be used with the CP 443-1 EX4x in PN IO mode	
Number of PN IO controllers	
<ul style="list-style-type: none"> • Via CP 443-1 in PN IO mode 	Maximum 4 in central rack, see manual for CP 443-1, no combined operation of CP 443-1 EX40 and CP 443-1 EX41/EX20/GX20
Number of plug-in S5 modules via adapter casing (in the central rack)	Maximum 6
Operable function modules and communication processors	
<ul style="list-style-type: none"> • FM 	Limited by the number of slots and the number of connections
<ul style="list-style-type: none"> • CP 440 	Limited by the number of slots
<ul style="list-style-type: none"> • CP 441 	Limited by the number of connections
<ul style="list-style-type: none"> • PROFIBUS and Ethernet CPs including CP 443-5 Extended and IM 467 	Maximum 14, of which no more than 10 may be CPs or IMs as DP master, up to 4 PN IO controllers
Time	
Clock	Yes
<ul style="list-style-type: none"> • Buffered 	Yes
<ul style="list-style-type: none"> • Resolution 	1 ms
<ul style="list-style-type: none"> • Accuracy after POWER OFF 	Maximum deviation per day 1.7 s
<ul style="list-style-type: none"> • Accuracy after POWER ON 	Maximum deviation per day 8.6 s
Operating hours counter	16
<ul style="list-style-type: none"> • Number 	0 to 15
<ul style="list-style-type: none"> • Value range 	0 to 32767 hours 0 to 2 ³¹ -1 hours when SFC 101 is used
<ul style="list-style-type: none"> • Granularity 	1 hour
<ul style="list-style-type: none"> • Retentive 	Yes
Time synchronization	Yes
<ul style="list-style-type: none"> • In PLC, on MPI and DP 	As master or slave

Time difference in the system with synchronization via MPI	Maximum 200 ms
S7 message functions	
Number of stations that can log on for message functions (e.g. WIN CC or SIMATIC OP)	Maximum 8 with ALARM_8 or ALARM_P (WinCC); up to 31 with ALARM_S or ALARM_D (OPs)
Symbol-related messages	Yes
<ul style="list-style-type: none"> Number of messages <ul style="list-style-type: none"> Total 100 ms interval 500 ms interval 1000 ms interval 	Maximum 512 None Maximum 256 Maximum 256
<ul style="list-style-type: none"> Number of auxiliary values per message <ul style="list-style-type: none"> With 100 ms interval With 500, 1000 ms interval 	None 1
Block-related messages	Yes
<ul style="list-style-type: none"> Simultaneously active ALARM_S/SQ blocks and ALARM_D/DQ blocks 	Maximum 250
ALARM_8 blocks	Yes
<ul style="list-style-type: none"> Number of communication jobs for ALARM_8 blocks and blocks for S7 communication (programmable) 	Maximum 300
<ul style="list-style-type: none"> Default 	150
Process control messages	Yes
Number of archives that can log on simultaneously (SFB 37 AR_SEND)	4
Test and startup functions	
Status/modify variable	Yes, maximum 16 variable tables
<ul style="list-style-type: none"> Variable 	Inputs/outputs, bit memories, DB, distributed inputs/outputs, timers, counters
<ul style="list-style-type: none"> Number of variables 	Maximum 70
Force	Yes
<ul style="list-style-type: none"> Variable 	Inputs/outputs, bit memories, distributed inputs/outputs
<ul style="list-style-type: none"> Number 	Maximum 64
Status block	Yes, maximum 2 blocks at the same time
Single-step	Yes
Number of breakpoints	4
Diagnostic buffer	Yes
<ul style="list-style-type: none"> Number of entries 	Maximum 400 (programmable)
<ul style="list-style-type: none"> Default 	120
Cyclic interrupts	
Value range	500 µs to 60000 ms

10.2 Specifications of the CPU 412-2 (6ES7412-2XJ05-0AB0)

Communication	
PG/OP communication	Yes
Number of connectable OPs	31
Number of connection resources for S7 connections via all interfaces and CPs	32, with one each of those reserved for programming device and OP
Global data communication	Yes
• Number of GD circuits	Maximum 8
• Number of GD packets Sender Receiver	Maximum 8 Maximum 16
• Size of GD packets Consistent of this	Maximum 54 bytes 1 variable
S7 basic communication	Yes
• MPI Mode	Via SFC X_SEND, X_RCV, X_GET and X_PUT
• DP Master Mode	Via SFC I_GET and I_PUT
• User data per job Consistent of this	Maximum 76 bytes 1 variable
S7 communication	Yes
• User data per job Consistent of this	Maximum 64 KB 1 variable (462 bytes)
S5-compatible communication	Via FC AG_SEND and AG_RECV, max. via 10 CP 443-1 or 443-5)
• User data per job Consistent of this	Maximum 8 KB 240 bytes
• Number of simultaneous AG-SEND/AG-RECV jobs per CPU, maximum	24/24
Standard communication (FMS)	Yes (via CP and loadable FB)
Open IE communication	ISO on TCP via CP 443-1 and downloadable FBs
• Maximum data length	1452 bytes
Interfaces	
1st interface	
Type of interface	Integrated
Features	RS 485 / PROFIBUS
Electrically isolated	Yes
Power supply to interface 24 V rated voltage (15 to 30 VDC)	Maximum 150 mA
Number of connection resources	MPI: 32 DP: 16
Functionality	
• MPI	Yes
• PROFIBUS DP	DP master/DP slave

10.2 Specifications of the CPU 412-2 (6ES7412-2XJ05-0AB0)

1st interface MPI mode	
Services	
PG/OP communication	Yes
Routing	Yes
Global data communication	Yes
S7 basic communication	Yes
S7 communication	Yes
Time synchronization	Yes
Transmission rates	Up to 12 Mbps
1st interface DP master mode	
Services	
PG/OP communication	Yes
Routing	Yes
S7 basic communication	Yes
S7 communication	Yes
Constant cycle	Yes
SYNC/FREEZE	Yes
Activate/deactivate DP slaves	Yes
Time synchronization	Yes
Direct data communication (internetwork traffic)	Yes
Transmission rates	Up to 12 Mbps
Number of DP slaves	Maximum 32
Number of slots per interface	Maximum 544
Address area	Maximum 2 KB inputs / 2 KB outputs
User data per DP slave	Maximum 244 bytes maximum 244 bytes I and maximum 244 bytes O, maximum 244 slots maximum 128 bytes per slot
Note:	
<ul style="list-style-type: none"> • The total sum of the input bytes across all slots may not exceed 244. • The total sum of the output bytes across all slots may not exceed 244. • The address range of the interface (maximum 2 KB inputs / 2 KB outputs) must not be exceeded in total across all 32 slaves. 	
1st interface DP slave mode	
You can only configure the CPU once as a DP slave even if the CPU has several interfaces.	
Service	
Status/modify	Yes
Programming	Yes
Routing	Yes
Time synchronization	Yes
GSD file (http://support.automation.siemens.com/WW/view/en/113652)	
Transmission rate	Up to 12 Mbps
Transfer memory	244 bytes inputs / 244 bytes outputs
Virtual slots	Maximum 32
User data per address area	Maximum 32 bytes
Consistent of this	32 bytes

10.2 Specifications of the CPU 412-2 (6ES7412-2XJ05-0AB0)

2nd interface	
Type of interface	Integrated
Features	RS 485 / PROFIBUS
Electrically isolated	Yes
Power supply to interface (15 VDC to 30 VDC)	Maximum 150 mA
Number of connection resources	16
Functionality	
• PROFIBUS DP	DP master/DP slave
2nd interface DP master mode	
Services	
PG/OP communication	Yes
Routing	Yes
S7 basic communication	Yes
S7 communication	Yes
Constant cycle	Yes
SYNC/FREEZE	Yes
Activate/deactivate DP slaves	Yes
Time synchronization	Yes
Direct data communication (internetwork traffic)	Yes
Transmission rates	Up to 12 Mbps
Number of DP slaves	Maximum 64
Number of slots per interface	Maximum 1088
Address area	Maximum 4 KB inputs / 4 KB outputs
User data per DP slave	Maximum 244 bytes maximum 244 bytes I and maximum 244 bytes O, maximum 244 slots maximum 128 bytes per slot
Note:	
<ul style="list-style-type: none"> • The total sum of the input bytes across all slots may not exceed 244. • The total sum of the output bytes across all slots may not exceed 244. • The address area of the interface (max. 4 KB inputs / 4 KB outputs) may not be exceeded in sum across all 64 slaves. 	
2nd interface DP slave mode	
Specifications as for 1st interface	
Programming	
Programming language	LAD, FBD, STL, SCL, S7 GRAPH, S7 HiGraph
Instruction set	See <i>Instruction List</i>
Nesting levels	7
System functions (SFC)	See <i>Instruction List</i>
Number of simultaneously active SFCs per segment	
• SFC 11 "DP_SYC_FR"	2
• SFC 12 "D_ACT_DP"	8
• SFC 59 "RD_REC"	8
• SFC 58 "WR_REC"	8

10.2 Specifications of the CPU 412-2 (6ES7412-2XJ05-0AB0)

• SFC 55 "WR_PARM"	8
• SFC 57 "PARM_MOD"	1
• SFC 56 "WR_DPARM"	2
• SFC 13 "DPNRM_DG"	8
• SFC 51 "RDSYSST"	1 ... 8
• SFC 103 "DP_TOPOL"	1
System function blocks (SFB)	See <i>Instruction List</i>
Number of simultaneously active SFBs	
• SFB 52 "RDREC"	8
• SFB 53 "WRREC"	8
User program protection	Password protection
Access to consistent data in the process image	Yes
CiR synchronization time	
Base load	100 ms
Time per I/O byte	30 µs
Isochronous mode	
User data per isochronous slave	Maximum 244 bytes
Maximum number of bytes and slaves in a process image partition	The following must apply: Number of bytes/100 + number of slaves < 16
Constant bus cycle time	Yes
Shortest clock pulse	1.5 ms 0.5 ms without use of SFC 126, 127
Longest clock pulse	32 ms
See <i>Isochronous Mode</i> manual	
Dimensions	
Mounting dimensions WxHxD (mm)	25x290x219
Slots required	1
Weight	Approx. 0.72 kg
Voltages, currents	
Current consumption from the S7-400 bus (5 VDC)	Typically 0.9 A Maximum 1.1 A
Current consumption from S7-400 bus (24 VDC) The CPU does not consume any current at 24 V, it only makes this voltage available at the MPI/DP interface.	Total current consumption of the components connected to the MPI/DP interfaces, with a maximum of 150 mA per interface
Backup current	Typically 125 µA (up to 40° C) Maximum 550 µA
Maximum backup time	See Module Specifications reference manual, Section 3.3.
Supply of external backup voltage to CPU	5 to 15 VDC
Power loss	Typically 4.5 W

10.3 Specifications of the CPU 414-2 (6ES7414-2XK05-0AB0)

Data

CPU and firmware version	
MLFB	6ES7414-2XK05-0AB0
• Firmware version	V 5.3
Associated programming package	as of STEP 7 V 5.3 SP2 + hardware update see also Introduction (Page 11)
Memory	
Work memory	
• Integrated	512 KB for code 512 KB for data
Load memory	
• Integrated	512 KB RAM
• Expandable FEPR0M	With memory card (FLASH) up to 64 MB
• Expandable RAM	With memory card (RAM) up to 64 MB
Backup with battery	Yes, all data
Typical processing times	
Processing times of	
• Bit operations	45 ns
• Word operations	45 ns
• Fixed-point arithmetic	45 ns
• Floating-point arithmetic	135 ns
Timers/counters and their retentivity	
S7 counters	2048
• Retentivity programmable	From C 0 to C 2047
• Default	From C 0 to C 7
• Counting range	0 to 999
IEC counters	Yes
• Type	SFB
S7 timers	2048
• Retentivity programmable	From T 0 to T 2047
• Default	No retentive timers
• Time range	10 ms to 9990 s
IEC timers	Yes
• Type	SFB

10.3 Specifications of the CPU 414-2 (6ES7414-2XK05-0AB0)

Data areas and their retentivity	
Total retentive data area (including bit memories, timers, counters)	Total work and load memory (with backup battery)
Bit memory	8 KB
• Retentivity programmable	From MB 0 to MB 8191
• Default retentive address areas	From MB 0 to MB 15
Clock flag bits	8 (1 flag byte)
Data blocks	Maximum 6000 (DB 0 reserved) Band of numbers 1 - 16000
• Size	Maximum 64 KB
Local data (programmable)	Maximum 16 KB
• Default	8 KB
Blocks	
OBs	See <i>Instruction List</i>
• Size	Maximum 64 KB
Nesting depth	
• Per priority class	24
• Additionally within an error OB	1
FBs	Maximum 3000 Band of numbers 0 - 7999
• Size	Maximum 64 KB
FCs	Maximum 3000 Band of numbers 0 - 7999
• Size	Maximum 64 KB
SDBs	Maximum 2048
Address areas (I/O)	
Total I/O address area	8 KB / 8 KB including diagnostics addresses, addresses for I/O interface modules, etc
Distributed of this	
• MPI/DP interface	2 KB / 2 KB
• DP interface	6 KB / 6 KB
Process image	8 KB/8 KB (programmable)
• Default	256 bytes / 256 bytes
• Number of process image partitions	Maximum 15
Consistent data	Maximum 244 bytes
Digital channels	Maximum 65536 / maximum 65536
• Of those are central	Maximum 65536 / maximum 65536
Analog channels	Maximum 4096 / maximum 4096
• Of those are central	Maximum 4096 / maximum 4096

10.3 Specifications of the CPU 414-2 (6ES7414-2XK05-0AB0)

Configuration	
Central racks/expansion units	Maximum 1/21
Multicomputing	Maximum 4 CPUs with UR1 or UR2 maximum 2 CPUs with CR3
Number of plug-in IMs (total)	Maximum 6
• IM 460	Maximum 6
• IM 463-2	Maximum 4
Number of DP masters	
• Integrated	2
• Via IM 467	Maximum 4
• Via CP 443-5 Extended	Maximum 10
IM 467 cannot be used with the CP 443-5 Extended IM 467 cannot be used with the CP 443-1 EX4x in PN IO mode	
Number of PN IO controllers	
• Via CP 443-1 in PN IO mode	Maximum 4 in central rack, see manual for CP 443-1, no combined operation of CP 443-1 EX 40 and CP 443-1EX41/EX20/GX20
Number of plug-in S5 modules via adapter casing (in the central rack)	Maximum 6
Operable function modules and communication processors	
• FM	Limited by the number of slots and the number of connections
• CP 440	Limited by the number of slots
• CP 441	Limited by the number of connections
• PROFIBUS and Ethernet CPs, LANs incl. CP 443-5 Extended and IM 467	Maximum 14, of which no more than 10 may be CPs or IMs as DP master, up to 4 PN IO controllers
Time	
Clock	Yes
• Buffered	Yes
• Resolution	1 ms
• Accuracy after POWER OFF	Maximum deviation per day 1.7 s
• Accuracy after POWER ON	Maximum deviation per day 8.6 s
Operating hours counter	16
• Number	0 to 5
• Value range	0 to 32767 hours 0 to 2 ³¹ -1 hours when SFC 101 is used
• Granularity	1 hour
• Retentive	Yes
Time synchronization	Yes
• In PLC, on MPI and DP	As master or slave

10.3 Specifications of the CPU 414-2 (6ES7414-2XK05-0AB0)

Time difference in the system with synchronization via MPI	Maximum 200 ms
S7 message functions	
Number of stations that can log on for message functions (e.g. WIN CC or SIMATIC OP)	Maximum 8 with ALARM_8 or ALARM_P (WinCC); up to 31 with ALARM_S or ALARM_D (OPs)
Symbol-related messages	Yes
<ul style="list-style-type: none"> • Number of messages <li style="padding-left: 20px;">Total <li style="padding-left: 20px;">100 ms interval <li style="padding-left: 20px;">500 ms interval <li style="padding-left: 20px;">1000 ms interval 	<ul style="list-style-type: none"> Maximum 512 Maximum 128 Maximum 256 Maximum 512
<ul style="list-style-type: none"> • Number of auxiliary values per message <li style="padding-left: 20px;">With 100 ms interval <li style="padding-left: 20px;">With 500, 1000 ms interval 	<ul style="list-style-type: none"> Maximum 1 Maximum 10
Block-related messages	Yes
<ul style="list-style-type: none"> • Simultaneously active alarm_S/SQ blocks and alarm_D/DQ blocks 	Maximum 400
Alarm-8 blocks	Yes
<ul style="list-style-type: none"> • Number of communication jobs for alarm_8 blocks and blocks for S7 communication (programmable) 	Maximum 1200
<ul style="list-style-type: none"> • Default 	300
Process control messages	Yes
Number of archives that can log on simultaneously (SFB 37 AR_SEND)	16
Test and startup functions	
Status/modify variable	Yes, maximum 16 variable tables
<ul style="list-style-type: none"> • Variable 	Inputs/outputs, bit memories, DB, distributed inputs/outputs, timers, counters
<ul style="list-style-type: none"> • Number of variables 	Maximum 70
Force	Yes
<ul style="list-style-type: none"> • Variable 	Inputs/outputs, bit memories, distributed inputs/outputs
<ul style="list-style-type: none"> • Number of variables 	Maximum 256
Status block	Yes, maximum 2 blocks at the same time
Single-step	Yes
Number of breakpoints	4
Diagnostic buffer	Yes
<ul style="list-style-type: none"> • Number of entries 	Maximum 400 (programmable)
<ul style="list-style-type: none"> • Default 	120
Cyclic interrupts	
Value range	500 µs to 60000 ms

10.3 Specifications of the CPU 414-2 (6ES7414-2XK05-0AB0)

Communication	
PG/OP communication	Yes
Number of connectable OPs	31
Number of connection resources for S7 connections via all interfaces and CPs	32, with one each of those reserved for programming device and OP
Global data communication	Yes
• Number of GD circuits	Maximum 8
• Number of GD packets Sender Receiver	Maximum 8 Maximum 16
• Size of GD packets Consistent of this	Maximum 54 bytes 1 variable
S7 basic communication	Yes
• MPI Mode	Via SFC X_SEND, X_RCV, X_GET and X_PUT
• DP Master Mode	Via SFC I_GET and I_PUT
• User data per job Consistent of this	Maximum 76 bytes 1 variable
S7 communication	Yes
• User data per job Consistent of this	Maximum 64 KB 1 variable (462 bytes)
S5-compatible communication	Via FC AG_SEND and AG_RECV, max. via 10 CP 443-1 or 443-5)
• User data per job Consistent of this	Maximum 8 KB 240 bytes
• Number of simultaneous AG-SEND/AG-RECV jobs per CPU, maximum	24/24
Standard communication (FMS)	Yes (via CP and loadable FBs)
Open IE communication	ISO on TCP via CP 443-1 and downloadable FBs
• Maximum data length	1452 bytes
Interfaces	
1st interface	
Type of interface	Integrated
Features	RS 485 / PROFIBUS
Electrically isolated	Yes
Power supply to interface 24 V rated voltage (15 to 30 VDC)	Maximum 150 mA
Number of connection resources	MPI: 32 DP: 16
Functionality	
MPI	Yes
PROFIBUS DP	DP master/DP slave

10.3 Specifications of the CPU 414-2 (6ES7414-2XK05-0AB0)

1st interface MPI mode	
Services	
PG/OP communication	Yes
Routing	Yes
Global data communication	Yes
S7 basic communication	Yes
S7 communication	Yes
Time synchronization	Yes
Transmission rates	Up to 12 Mbps
1st interface DP master mode	
Services	
PG/OP communication	Yes
Routing	Yes
S7 basic communication	Yes
S7 communication	Yes
Constant cycle	Yes
SYNC/FREEZE	Yes
Activate/deactivate DP slaves	Yes
Time synchronization	Yes
Direct data communication / internetwork traffic	Yes
Transmission rates	Up to 12 Mbps
Number of DP slaves	Maximum 32
Number of slots per interface	Maximum 544
Address area	Maximum 2 KB inputs / 2 KB outputs
User data per DP slave	Maximum 244 bytes maximum 244 bytes I and maximum 244 bytes O, maximum 244 slots maximum 128 bytes per slot
Note:	
<ul style="list-style-type: none"> • The total sum of the input bytes across all slots may not exceed 244. • The total sum of the output bytes across all slots may not exceed 244. • The address range of the interface (maximum 2 KB inputs / 2 KB outputs) must not be exceeded in total across all 32 slaves. 	
1st interface DP slave mode	
You can only configure the CPU once as a DP slave even if the CPU has several interfaces.	
Service	
Status/modify	Yes
Programming	Yes
Routing	Yes
Time synchronization	Yes
GSD file (http://support.automation.siemens.com/WW/view/en/113652)	
Transmission rate	Up to 12 Mbps
Transfer memory	244 bytes inputs / 244 bytes outputs
Virtual slots	Maximum 32
User data per address area	Maximum 32 bytes
Consistent of this	32 bytes

10.3 Specifications of the CPU 414-2 (6ES7414-2XK05-0AB0)

2nd interface	
Type of interface	Integrated
Features	RS 485 / PROFIBUS
Electrically isolated	Yes
Power supply to interface 24 V rated voltage (15 to 30 VDC)	Maximum 150 mA
Number of connection resources	16
Functionality	
<ul style="list-style-type: none"> • PROFIBUS DP 	DP master/DP slave
2nd interface DP master mode	
Services	
PG/OP communication	Yes
Routing	Yes
S7 basic communication	Yes
S7 communication	Yes
Constant cycle	Yes
SYNC/FREEZE	Yes
Activate/deactivate DP slaves	Yes
Time synchronization	Yes
Direct data communication (internetwork traffic)	Yes
Transmission rates	Up to 12 Mbps
Number of DP slaves	Maximum 96
Number of slots per interface	Maximum 1632
Address area	Maximum 6 KB inputs / 6 KB outputs
User data per DP slave	Maximum 244 bytes maximum 244 bytes I and maximum 244 bytes O, maximum 244 slots maximum 128 bytes per slot
Note:	
<ul style="list-style-type: none"> • The total sum of the input bytes across all slots may not exceed 244. • The total sum of the output bytes across all slots may not exceed 244. • The address area of the interface (max. 6 KB inputs / 6 KB outputs) may not be exceeded in sum across all 96 slaves. 	
2nd interface DP slave mode	
Specifications as for 1st interface	
Programming	
Programming language	LAD, FBD, STL, SCL, S7 GRAPH, S7 HiGraph
Instruction set	See <i>Instruction List</i>
Nesting levels	7
System functions (SFC)	See <i>Instruction List</i>
System function blocks (SFB)	See <i>Instruction List</i>
Number of simultaneously active SFCs per segment	
<ul style="list-style-type: none"> • SFC 11 "DPSYC_FR" 	2
<ul style="list-style-type: none"> • SFC 12 "D_ACT_DP" 	8
<ul style="list-style-type: none"> • SFC 59 "RD_REC" 	8

10.3 Specifications of the CPU 414-2 (6ES7414-2XK05-0AB0)

• SFC 58 "WR_REC"	8
• SFC 55 "WR_PARM"	8
• SFC 57 "PARM_MOD"	1
• SFC 56 "WR_DPARM"	2
• SFC 13 "DPNRM_DG"	8
• SFC 51 "RDSYSST"	1... 8
• SFC 103 "DP_TOPOL"	1
System function blocks (SFB)	See <i>Instruction List</i>
Number of simultaneously active SFBs	
• SFB 52 "RDREC"	8
• SFB 53 "WRREC"	8
User program protection	Password protection
Access to consistent data in the process image	Yes
CiR synchronization time	
Base load	100 ms
Time per I/O byte	15 µs
Isochronous mode	
User data per isochronous slave	Maximum 244 bytes
Maximum number of bytes and slaves in a process image partition	The following must apply: number of bytes/100 + number of slaves < 26
Constant bus cycle time	Yes
Shortest clock pulse	1 ms 0.5 ms without use of SFC 126, 127
Longest clock pulse	32 ms
See <i>Isochronous Mode</i> manual	
Dimensions	
Mounting dimensions WxHxD (mm)	25x290x219
Slots required	1
Weight	Approx. 0.72 kg
Voltages, currents	
Current consumption from the S7-400 bus (5 VDC)	Typically 0.9 A Maximum 1.1 A
Current consumption from S7-400 bus (24 VDC) The CPU does not consume any current at 24 V, it only makes this voltage available at the MPI/DP interface.	Total current consumption of the components connected to the MPI/DP interfaces, with a maximum of 150 mA per interface
Backup current	Typically 125 µA (up to 40° C) Maximum 550 µA
Maximum backup time	See <i>Module Specifications</i> reference manual, Section 3.3.
Supply of external backup voltage to CPU	5 to 15 VDC
Power loss	Typically 4.5 W

10.4 Specifications of the CPU 414-3 (6ES7414-3XM05-0AB0)

Data

CPU and firmware version	
MLFB	6ES7414-3XM05-0AB0
• Firmware version	V 5.3
Associated programming package	as of STEP 7 V 5.3 SP2 + hardware update see also Introduction (Page 11)
Memory	
Work memory	
• Integrated	1.4 MB for code 1.4 MB for data
Load memory	
• Integrated	512 KB RAM
• Expandable FEPR0M	With memory card (FLASH) up to 64 MB
• Expandable RAM	With memory card (RAM) up to 64 MB
Backup with battery	Yes, all data
Typical processing times	
Processing times of	
• Bit operations	45 ns
• Word operations	45 ns
• Fixed-point arithmetic	45 ns
• Floating-point arithmetic	135 ns
Timers/counters and their retentivity	
S7 counters	2048
• Retentivity programmable	From C 0 to C 2047
• Default	From C 0 to C 7
• Counting range	0 to 999
IEC counters	Yes
• Type	SFB
S7 timers	2048
• Retentivity programmable	From T 0 to T 2047
• Default	No retentive timers
• Time range	10 ms to 9990 s
IEC timers	Yes
• Type	SFB

Data areas and their retentivity	
Total retentive data area (including bit memories, timers, counters)	Total work and load memory (with backup battery)
Bit memory	8 KB
<ul style="list-style-type: none"> Retentivity programmable 	From MB 0 to MB 8191
<ul style="list-style-type: none"> Default retentive address areas 	From MB 0 to MB 15
Clock flag bits	8 (1 flag byte)
Data blocks	Maximum 6000 (DB 0 reserved) Band of numbers 1 - 16000
<ul style="list-style-type: none"> Size 	Maximum 64 KB
Local data (programmable)	Maximum 16 KB
<ul style="list-style-type: none"> Default 	8 KB
Blocks	
OBs	See <i>Instruction List</i>
<ul style="list-style-type: none"> Size 	Maximum 64 KB
Nesting depth	
<ul style="list-style-type: none"> Per priority class 	24
<ul style="list-style-type: none"> Additionally within an error OB 	1
FBs	Maximum 3000 Band of numbers 0 - 7999
<ul style="list-style-type: none"> Size 	Maximum 64 KB
FCs	Maximum 3000 Band of numbers 0 - 7999
<ul style="list-style-type: none"> Size 	Maximum 64 KB
SDBs	Maximum 2048
Address areas (I/O)	
Total I/O address area	8 KB / 8 KB including diagnostics addresses, addresses for I/O interface modules, etc
Distributed of this	
<ul style="list-style-type: none"> MPI/DP interface 	2 KB / 2 KB
<ul style="list-style-type: none"> DP interface 	6 KB / 6 KB
Process image	8 KB/8 KB (programmable)
<ul style="list-style-type: none"> Default 	256 bytes / 256 bytes
<ul style="list-style-type: none"> Number of process image partitions 	Maximum 15
Consistent data	Maximum 244 bytes
Digital channels	Maximum 65536 / maximum 65536
<ul style="list-style-type: none"> Of those are central 	Maximum 65536 / maximum 65536
Analog channels	Maximum 4096 / maximum 4096
<ul style="list-style-type: none"> Of those are central 	Maximum 4096 / maximum 4096

10.4 Specifications of the CPU 414-3 (6ES7414-3XM05-0AB0)

Configuration	
Central racks/expansion units	Maximum 1/21
Multicomputing	Maximum 4 CPUs with UR1 or UR2 maximum 2 CPUs with CR3
Number of plug-in IMs (total)	Maximum 6
• IM 460	Maximum 6
• IM 463-2	Maximum 4
Number of DP masters	
• Integrated	2
• Via IF 964-DP	1
• Via IM 467	Maximum 4
• Via CP 443-5 Extended	Maximum 10
IM 467 cannot be used with the CP 443-5 Extended IM 467 cannot be used with the CP 443-1 EX4x in PN IO mode	
Number of PN IO controllers	
• Via CP 443-1 in PN IO mode	Maximum 4 in central rack, see manual for CP 443-1, no combined operation of CP 443-1 EX40 and CP 443-1 EX41/EX20/GX20
Number of plug-in S5 modules via adapter casing (in the central rack)	Maximum 6
Operable FMs and CPs	
• FM	Limited by the number of slots and the number of connections
• CP 440	Limited by the number of slots
• CP 441	Limited by the number of connections
• PROFIBUS and Ethernet CPs including CP 443-5 Extended and IM 467	Maximum 14 No more than 10 of which may be CPs or IMs as DP master, up to 4 PN IO controllers
Time	
Clock	Yes
• Buffered	Yes
• Resolution	1 ms
• Accuracy after POWER OFF	Maximum deviation per day 1.7 s
• Accuracy after POWER ON	Maximum deviation per day 8.6 s
Operating hours counter	16
• Number	0 to 15
• Value range	0 to 32767 hours 0 to 2 ³¹ -1 hours when SFC 101 is used
• Granularity	1 hour
• Retentive	Yes
Time synchronization	Yes
• In PLC, on MPI, DP and IF 964 DP	As master or slave

10.4 Specifications of the CPU 414-3 (6ES7414-3XM05-0AB0)

Time difference in the system with synchronization via MPI	Maximum 200 ms
S7 message functions	
Number of stations that can log on for message functions (e.g. WIN CC or SIMATIC OP)	Maximum 8 with ALARM_8 or ALARM_P (WinCC); up to 31 with ALARM_S or ALARM_D (OPs)
Symbol-related messages	Yes
<ul style="list-style-type: none"> Number of messages <ul style="list-style-type: none"> Total 100 ms interval 500 ms interval 1000 ms interval 	Maximum 512 Maximum 128 Maximum 256 Maximum 512
<ul style="list-style-type: none"> Number of auxiliary values per message <ul style="list-style-type: none"> With 100 ms interval With 500, 1000 ms interval 	Maximum 1 Maximum 10
Block-related messages	Yes
<ul style="list-style-type: none"> Simultaneously active ALARM_S/SQ blocks and ALARM_D/DQ blocks 	Maximum 400
ALARM_8 blocks	Yes
<ul style="list-style-type: none"> Number of communication jobs for ALARM_8 blocks and blocks for S7 communication (programmable) 	Maximum 1200
<ul style="list-style-type: none"> Default 	300
Process control messages	Yes
Number of archives that can log on simultaneously (SFB 37 AR_SEND)	16
Test and startup functions	
Status/modify variable	Yes, maximum 16 variable tables
<ul style="list-style-type: none"> Variable 	Inputs/outputs, bit memories, DB, distributed inputs/outputs, timers, counters
<ul style="list-style-type: none"> Number of variables 	Maximum 70
Force	Yes
<ul style="list-style-type: none"> Variable 	Inputs/outputs, bit memories, distributed inputs/outputs
<ul style="list-style-type: none"> Number of variables 	Maximum 256
Status block	Yes, maximum 2 blocks at the same time
Single-step	Yes
Number of breakpoints	4
Diagnostic buffer	Yes
<ul style="list-style-type: none"> Number of entries 	Maximum 3200 (programmable)
<ul style="list-style-type: none"> Default 	120
Cyclic interrupts	
Value range	500 µs to 60000 ms

10.4 Specifications of the CPU 414-3 (6ES7414-3XM05-0AB0)

Communication	
PG/OP communication	Yes
Number of connectable OPs	31
Number of connection resources for S7 connections via all interfaces and CPs	32, with one each of those reserved for programming device and OP
Global data communication	Yes
• Number of GD circuits	Maximum 8
• Number of GD packets Sender Receiver	Maximum 8 Maximum 16
• Size of GD packets Consistent of this	Maximum 54 bytes 1 variable
S7 basic communication	Yes
• MPI Mode	Via SFC X_SEND, X_RCV, X_GET and X_PUT
• DP Master Mode	Via SFC I_GET and I_PUT
• User data per job Consistent of this	Maximum 76 bytes 1 variable
S7 communication	Yes
• User data per job Consistent of this	Maximum 64 KB 1 variable (462 bytes)
S5-compatible communication	Via FC AG_SEND and AG_RECV, max. via 10 CP 443-1 or 443-5)
• User data per job Consistent of this	Maximum 8 KB 240 bytes
• Number of simultaneous AG-SEND/AG-RECV jobs per CPU, maximum	24/24
Standard communication (FMS)	Yes (via CP and loadable FBs)
Open IE communication	ISO on TCP via CP 443-1 and downloadable FBs
• Maximum data length	1452 bytes
Interfaces	
1st interface	
Type of interface	Integrated
Features	RS 485 / PROFIBUS
Electrically isolated	Yes
Power supply to interface 24 V rated voltage (15 to 30 VDC)	Maximum 150 mA
Number of connection resources	MPI: 32 DP: 16
Functionality	
• MPI	Yes
• PROFIBUS DP	DP master/DP slave

1st interface MPI mode	
Services	
PG/OP communication	Yes
Routing	Yes
Global data communication	Yes
S7 basic communication	Yes
S7 communication	Yes
Time synchronization	Yes
Transmission rates	Up to 12 Mbps
1st interface DP master mode	
Services	
PG/OP communication	Yes
Routing	Yes
S7 basic communication	Yes
S7 communication	Yes
Constant cycle	Yes
SYNC/FREEZE	Yes
Activate/deactivate DP slaves	Yes
Time synchronization	Yes
Direct data communication (internetwork traffic)	Yes
Transmission rates	Up to 12 Mbps
Number of DP slaves	Maximum 32
Number of slots per interface	Maximum 544
Address area	Maximum 2 KB inputs / 2 KB outputs
User data per DP slave	Maximum 244 bytes maximum 244 bytes I and maximum 244 bytes O, maximum 244 slots maximum 128 bytes per slot
Note:	
<ul style="list-style-type: none"> • The total sum of the input bytes across all slots may not exceed 244. • The total sum of the output bytes across all slots may not exceed 244. • The address range of the interface (maximum 2 KB inputs / 2 KB outputs) must not be exceeded in total across all 32 slaves. 	
1st interface DP slave mode	
You can only configure the CPU once as a DP slave even if the CPU has several interfaces.	
Service	
Status/modify	Yes
Programming	Yes
Routing	Yes
Time synchronization	Yes
GSD file (http://support.automation.siemens.com/WW/view/en/113652)	
Transmission rate	Up to 12 Mbps
Transfer memory	244 bytes inputs / 244 bytes outputs
Virtual slots	Maximum 32
User data per address area	Maximum 32 bytes
Consistent of this	32 bytes

10.4 Specifications of the CPU 414-3 (6ES7414-3XM05-0AB0)

2nd interface	
Type of interface	Integrated
Features	RS 485 / PROFIBUS
Electrically isolated	Yes
Power supply to interface 24 V rated voltage (15 to 30 VDC)	Maximum 150 mA
Number of connection resources	16
Functionality	
PROFIBUS DP	DP master/DP slave
2nd interface DP master mode	
Services	
PG/OP communication	Yes
Routing	Yes
S7 basic communication	Yes
S7 communication	Yes
Constant cycle	Yes
SYNC/FREEZE	Yes
Activate/deactivate DP slaves	Yes
Time synchronization	Yes
Direct data communication (internetwork traffic)	Yes
Transmission rates	Up to 12 Mbps
Number of DP slaves	Maximum 96
Number of slots per interface	Maximum 1632
Address area	Maximum 6 KB inputs / 6 KB outputs
User data per DP slave	Maximum 244 bytes maximum 244 bytes I and maximum 244 bytes O, maximum 244 slots maximum 128 bytes per slot
Note:	
<ul style="list-style-type: none"> • The total sum of the input bytes across all slots may not exceed 244. • The total sum of the output bytes across all slots may not exceed 244. • The address area of the interface (max. 6 KB inputs / 6 KB outputs) may not be exceeded in sum across all 96 slaves. 	
2nd interface DP slave mode	
Specifications as for 1st interface	
3rd interface	
Type of interface	Plug-in interface module
Usable interface module	IF 964-DP
Technical features as for the 2nd interface	

Programming	
Programming language	LAD, FBD, STL, SCL, S7 GRAPH, S7 HiGraph
Instruction set	See <i>Instruction List</i>
Nesting levels	7
System functions (SFC)	See <i>Instruction List</i>
Number of simultaneously active SFCs per segment	
• SFC 11 "DPSYC_FR"	2
• SFC 12 "D_ACT_DP"	8
• SFC 59 "RD_REC"	8
• SFC 58 "WR_REC"	8
• SFC 55 "WR_PARM"	8
• SFC 57 "PARM_MOD"	1
• SFC 56 "WR_DPARM"	2
• SFC 13 "DPNRM_DG"	8
• SFC 51 "RDSYSST"	1... 8
• SFC 103 "DP_TOPOL"	1
System function blocks (SFB)	See <i>Instruction List</i>
Number of simultaneously active SFBs	
• SFB 52 "RDREC"	8
• SFB 53 "WRREC"	8
User program protection	Password protection
Access to consistent data in the process image	Yes
CiR synchronization time	
Base load	100 ms
Time per I/O byte	15 µs
Isochronous mode	
User data per isochronous slave	Maximum 244 bytes
Maximum number of bytes and slaves in a process image partition	The following must apply: number of bytes/100 + number of slaves < 26
Constant bus cycle time	Yes
Shortest clock pulse	1 ms 0.5 ms without use of SFC 126, 127
Longest clock pulse	32 ms
See <i>Isochronous Mode</i> manual	
Dimensions	
Mounting dimensions WxHxD (mm)	50x290x219
Slots required	2
Weight	Approx. 0.88 kg

10.4 Specifications of the CPU 414-3 (6ES7414-3XM05-0AB0)

Voltages, currents	
Current consumption from the S7-400 bus (5 VDC)	Typically 1.1 A Maximum 1.3 A
Current consumption from S7-400 bus (24 VDC) The CPU does not consume any current at 24 V, it only makes this voltage available at the MPI/DP interface.	Total current consumption of the components connected to the MPI/DP interfaces, with a maximum of 150 mA per interface
Backup current	Typically 125 µA (up to 40° C) Maximum 550 µA
Maximum backup time	See <i>Module Specifications</i> reference manual, Section 3.3.
Supply of external backup voltage to CPU	5 to 15 VDC
Power loss	Typically 5.5 W

10.5 Specifications of the CPU 414-3 PN/DP (6ES7414-3EM05-0AB0)

Data

CPU and firmware version	
MLFB	6ES7414-3EM05-0AB0
• Firmware version	V5.3
Associated programming package	As of STEP 7 V 5.4 SP4 + hardware update see also Introduction (Page 11)
Memory	
Work memory	
• Integrated	1.4 MB for code 1.4 MB for data
Load memory	
• Integrated	512 KB RAM
• Expandable FEPR0M	With memory card (FLASH) up to 64 MB
• Expandable RAM	With memory card (RAM) up to 64 MB
Backup with battery	Yes, all data
Typical processing times	
Processing times of	
• Bit operations	45 ns
• Word operations	45 ns
• Fixed-point arithmetic	45 ns
• Floating-point arithmetic	135 ns
Timers/counters and their retentivity	
S7 counters	2048
• Retentivity programmable	From Z 0 to Z 2047
• Default	From Z 0 to Z 7
• Counting range	0 to 999
IEC counters	Yes
• Type	SFB
S7 timers	2048
• Retentivity programmable	From T 0 to T 2047
• Default	No retentive timers
• Time range	10 ms to 9990 s
IEC timers	Yes
• Type	SFB

10.5 Specifications of the CPU 414-3 PN/DP (6ES7414-3EM05-0AB0)

Data areas and their retentivity	
Total retentive data area (including memory markers, timers, counters)	Total work and load memory (with backup battery)
Bit memory	8 KB
<ul style="list-style-type: none"> Retentivity programmable 	From MB 0 to MB 8191
<ul style="list-style-type: none"> Default retentive address areas 	From MB 0 to MB 15
Clock flag bits	8 (1 flag byte)
Data blocks	Maximum 6000 (DB 0 reserved) Band of numbers 1 - 16 000
<ul style="list-style-type: none"> Size 	Maximum 64 KB
Local data (programmable)	Maximum 16 KB
<ul style="list-style-type: none"> Default 	8 KB
Blocks	
OBs	See <i>Instruction List</i>
<ul style="list-style-type: none"> Size 	Maximum 64 KB
Nesting depth	
<ul style="list-style-type: none"> Per priority class 	24
<ul style="list-style-type: none"> Additionally within an error OB 	1
FBs	Maximum 3000 Band of numbers 0 - 7999
<ul style="list-style-type: none"> Size 	Maximum 64 KB
FCs	Maximum 3000 Band of numbers 0 - 7999
<ul style="list-style-type: none"> Size 	Maximum 64 KB
SDBs	Maximum 2048
Address areas (I/O)	
Total I/O address area	8 KB / 8 KB including diagnostics addresses, addresses for I/O interface modules, etc
Distributed of this	
<ul style="list-style-type: none"> MPI/DP interface 	2 KB / 2 KB
<ul style="list-style-type: none"> DP interface 	6 KB / 6 KB
<ul style="list-style-type: none"> PN interface 	8 KB / 8 KB
Process image	8 KB/8 KB (programmable)
<ul style="list-style-type: none"> Default 	256 bytes / 256 bytes
<ul style="list-style-type: none"> Number of process image partitions 	Maximum 15
Consistent data	Maximum 244 bytes
Digital channels	Maximum 65536 / maximum 65536
<ul style="list-style-type: none"> Of those are central 	Maximum 65536 / maximum 65536
Analog channels	Maximum 4096 / maximum 4096
<ul style="list-style-type: none"> Of those are central 	Maximum 4096 / maximum 4096

Configuration	
Central racks/expansion units	Maximum 1/21
Multicomputing	Maximum 4 CPUs with UR1 or UR2 maximum 2 CPUs with CR3
Number of plug-in IMs (total)	Maximum 6
• IM 460	Maximum 6
• IM 463-2	Maximum 4
Number of DP masters	
• Integrated	1
• Via IF 964-DP	1
• Via IM 467	Maximum 4
• Via CP 443-5 Extended	Maximum 10
IM 467 cannot be used with the CP 443-5 Extended IM 467 cannot be used with the CP 443-1 EX4x in PN IO mode	
Number of PN IO controllers	
• Integrated	1
• Via CP 443-1 in PN IO mode	Maximum 4 in central rack, see manual for CP 443-1, no combined operation of CP 443-1 EX40 and CP 443-1 EX41/EX20/GX20
Number of plug-in S5 modules via adapter casing (in the central rack)	Maximum 6
Operable FMs and CPs	
• FM	Limited by the number of slots and the number of connections
• CP 440	Limited by the number of slots
• CP 441	Limited by the number of connections
• PROFIBUS and Ethernet CPs including CP 443-5 Extended and IM 467	Maximum 14
Time	
Clock	Yes
• Buffered	Yes
• Resolution	1 ms
• Accuracy after POWER OFF	Maximum deviation per day 1.7 s
• Accuracy after POWER ON	Maximum deviation per day 8.6 s
Operating hours counter	16
• Number	0 to 15
• Value range	0 to 32767 hours 0 to 2 ³¹ -1 hours when SFC 101 is used
• Granularity	1 hour
• Retentive	Yes
Time synchronization	Yes

10.5 Specifications of the CPU 414-3 PN/DP (6ES7414-3EM05-0AB0)

• In PLC, on MPI, DP and IF 964 DP	As master or slave
• On Ethernet via NTP	Yes (as client)
Time difference in the system with synchronization via MPI	Maximum 200 ms
S7 message functions	
Number of stations that can be used	
For block-specific messages (Alarm_S/SQ or Alarm_D/DQ)	31
For control-specific messages (ALARM_8 blocks, archive)	8
Symbol-related messages	Yes
• Number of messages Total 100 ms interval 500 ms interval 1000 ms interval	Maximum 512 Maximum 128 Maximum 256 Maximum 512
• Number of auxiliary values per message With 100 ms interval With 500, 1000 ms interval	Maximum 1 Maximum 10
Block-related messages	Yes
• Simultaneously active ALARM_S/SQ blocks and ALARM_D/DQ blocks	Maximum 400
ALARM_8 blocks	Yes
• Number of communication jobs for ALARM_8 blocks and blocks for S7 communication (programmable)	Maximum 1200
• Default	300
Process control messages	Yes
Number of archives that can log on simultaneously (SFB 37 AR_SEND)	16
Test and startup functions	
Status/modify variable	Yes, maximum 16 variable tables
• Variable	Inputs/outputs, bit memories, DB, distributed I/O, timers, counters
• Number of tags	Maximum 70
Force	Yes
• Tag	Inputs/outputs, bit memories, distributed I/O
• Number of tags	Maximum 256
Status block	Yes, maximum 2 blocks at the same time
Single-step	Yes
Diagnostics buffer	Yes
• Number of entries	Maximum 3200 (programmable)
• Default	120
Number of breakpoints	4

Cyclic interrupts	
Value range	500 µs to 60000 ms
Communication	
PG/OP communication	Yes
Number of connectable OPs	31
Number of connection resources for S7 connections via all interfaces and CPs	32, with one each of those reserved for programming device and OP
Global data communication	Yes
<ul style="list-style-type: none"> Number of GD circuits 	Maximum 8
<ul style="list-style-type: none"> Number of GD packets Sender Receiver 	Maximum 8 Maximum 16
<ul style="list-style-type: none"> Size of GD packets Consistent of this 	Maximum 54 bytes 1 variable
S7 basic communication	Yes
<ul style="list-style-type: none"> MPI mode 	Via SFC X_SEND, X_RCV, X_GET and X_PUT
<ul style="list-style-type: none"> in DP master mode 	Via SFC I_GET and I_PUT
<ul style="list-style-type: none"> User data per job Consistent of those 	Maximum 76 bytes 1 variable
S7 communication	Yes
<ul style="list-style-type: none"> User data per job Consistent of those 	Maximum 64 KB 1 variable (462 bytes)
S5-compatible communication	Via FC AG_SEND and AG_RECV, max. via 10 CP 443-1 or 443-5)
<ul style="list-style-type: none"> User data per job Consistent of those 	Maximum 8 KB 240 bytes
<ul style="list-style-type: none"> Number of simultaneous AG-SEND/AG-RECV jobs per CPU, maximum 	24/24
Standard communication (FMS)	ISO on TCP via CP 443-1 and downloadable blocks
Web server	Yes
<ul style="list-style-type: none"> Number of http clients 	5
<ul style="list-style-type: none"> Variable tables 	Maximum 50, each with maximum 200 variables
<ul style="list-style-type: none"> Variable status 	Of max. 50 variables
<ul style="list-style-type: none"> Messages 	Per language max. 400 message texts with a total size of 512 KB

10.5 Specifications of the CPU 414-3 PN/DP (6ES7414-3EM05-0AB0)

Open IE communication via TCP/IP	
Number of connections / access points, total	Maximum 30
Possible Port Numbers	1 to 49151
Where parameters are assigned without specification of a port number, the system assigns a port from the dynamic port number range between 49152 and 65534	
Reserved Port Numbers	TCP 20, 21 FTP TCP 25 SMTP TCP 80 HTTP TCP 102 RFC1006 UDP 135 RPC-DCOM UDP 161 SNMP_REQUEST UDP 34964 PN IO UDP 65532 NTP UDP 65533 NTP UDP 65534 NTP UDP 65535 NT
TCP/IP	Yes, via integrated PROFINET interface and loadable FBs
<ul style="list-style-type: none"> • Maximum number of connections 	30
<ul style="list-style-type: none"> • Data length, max. 	32767 bytes
ISO on TCP	Yes (via integrated PROFINET interface or CP 443-1 EX40/EX41/ EX20/GX 20 and loadable FBs)
<ul style="list-style-type: none"> • Maximum number of connections 	30
<ul style="list-style-type: none"> • Maximum data length via integrated PROFINET interface 	32767 bytes
<ul style="list-style-type: none"> • Maximum data length via CP 443-1 	1452 bytes
UDP	Yes, via integrated PROFINET interface and loadable blocks
<ul style="list-style-type: none"> • Maximum number of connections 	30
<ul style="list-style-type: none"> • Data length, max. 	1472 bytes
PROFINET CBA	
Reference setting for the CPU communication load	20%
Number of remote interconnecting partners	32
Number of master/slave functions	150
Total of all master/slave connections	4500
Data length of all incoming master/slave connections, max.	45000 bytes
Data length of all outgoing master/slave connections, max.	45000 bytes
Number of device-internal and PROFIBUS interconnections	1000
Data length of the device-internal and PROFIBUS interconnections, max.	16000 bytes
Data length per connection, max.	2000 bytes
Remote interconnections with acyclic transmission	
<ul style="list-style-type: none"> • Scan rate: Scan interval, min. 	200 ms

10.5 Specifications of the CPU 414-3 PN/DP (6ES7414-3EM05-0AB0)

• Number of incoming interconnections	250
• Number of outgoing interconnections	250
• Data length of all incoming interconnections, max.	8000 bytes
• Data length of all outgoing interconnections, max.	8000 bytes
• Data length per connection, (acyclic interconnections), max.	2000 bytes
Remote interconnections with cyclic transmission	
• Transmission frequency: Minimum transmission interval	1 ms
• Number of incoming interconnections	300
• Number of outgoing interconnections	300
• Data length of all incoming interconnections, max.	4800 bytes
• Data length of all outgoing interconnections	4800 bytes
• Data length per connection, (acyclic interconnections), max.	250 bytes
HMI variables via PROFINET (acyclic)	
• Update HMI variables	500 ms
• Number of stations that can be logged on for HMI variables (PN OPC/iMAP)	2*PN OPC / 1* iMAP
• Number of HMI variables	1000
• Data length of all HMI variables, max.	32000 bytes
PROFIBUS proxy functionality	
• Supported	Yes
• Number of coupled PROFIBUS devices	32
• Data length per connection, max.	240 bytes (slave dependent)
Interfaces	
1st interface	
Type of interface	Integrated
Features	RS 485 / PROFIBUS
Electrically isolated	Yes
Power supply to interface 24 V rated voltage (15 to 30 VDC)	Maximum 150 mA
Number of connection resources	MPI: 32 DP: 16
Functionality	
MPI	Yes
PROFIBUS DP	DP master/DP slave

10.5 Specifications of the CPU 414-3 PN/DP (6ES7414-3EM05-0AB0)

1st interface MPI mode	
Services	
PG/OP communication	Yes
Routing	Yes
Global data communication	Yes
S7 basic communication	Yes
S7 communication	Yes
Time synchronization	Yes
Transmission rates	Up to 12 Mbps
1st interface DP master mode	
Services	
PG/OP communication	Yes
Routing	Yes
S7 basic communication	Yes
S7 communication	Yes
Constant cycle	Yes
SYNC/FREEZE	Yes
Activate/deactivate DP slaves	Yes
Time synchronization	Yes
Direct data communication (internetwork traffic)	Yes
Transmission rates	Up to 12 Mbps
Number of DP slaves	Maximum 32
Number of slots per interface	Maximum 544
Address area	Maximum 2 KB inputs / 2 KB outputs
User data per DP slave	Maximum 244 bytes maximum 244 bytes I and maximum 244 bytes O, maximum 244 slots maximum 128 bytes per slot
Note:	
<ul style="list-style-type: none"> • The total sum of the input bytes across all slots may not exceed 244. • The total sum of the output bytes across all slots may not exceed 244. • The address range of the interface (maximum 2 KB inputs / 2 KB outputs) must not be exceeded in total across all 32 slaves. 	
1st interface DP slave mode	
You can only configure the CPU once as a DP slave even if the CPU has several interfaces.	
Service	
Status/modify	Yes
Programming	Yes
Routing	Yes
Time synchronization	Yes
GSD file (http://support.automation.siemens.com/WW/view/en/113652)	
Transmission rate	Up to 12 Mbps
Transfer memory	244 bytes inputs / 244 bytes outputs
Virtual slots	Maximum 32
User data per address area	Maximum 32 bytes
Consistent of this	32 bytes

2nd interface	
Type of interface	Integrated
Features	Ethernet 2-port switch 2 x RJ45
Electrically isolated	Yes
Autosensing (10/100 Mbps)	Yes
Autonegotiation	Yes
Autocrossover	Yes
Functionality	
• PROFINET	Yes
Services	
• PG communication	Yes
• OP communication	Yes
• S7 communication Maximum number of configurable connections Maximum number of instances	Yes 32, with one each of those reserved for programming device and OP 600
• Routing	Yes
• PROFINET IO	Yes
• PROFINET CBA	Yes
Open IE communication	
• Via TCP/IP	Yes
• ISO on TCP	Yes
• UDP	Yes
• Time synchronization	Yes
PROFINET IO	
PNO ID (hexadecimal)	Vendor ID: 0x002A Device ID: 0x0102
Number of integrated PROFINET IO controllers	1
Number of PROFINET IO devices that can be connected	256
Address area	Maximum 8 KB inputs/outputs
Number of submodules	Maximum 8192 Mixed modules count twice
Maximum user data length including user data qualifiers	255 bytes per submodule
Maximum user data consistency including user data qualifiers	255 bytes per submodule

10.5 Specifications of the CPU 414-3 PN/DP (6ES7414-3EM05-0AB0)

Update time	250 µs, 0.5 ms, 1 ms, 2 ms, 4 ms, 8 ms, 16 ms, 32 ms, 64 ms, 128 ms, 256 ms and 512 ms The minimum value is determined by the set communication portion for PROFINET IO, the number of IO devices and the amount of configured user data.
S7 protocol functions	
• Programming device functions	Yes
• OP functions	Yes
IRT (Isochronous Real Time)	Yes, RT Class 2
• Option "with high flexibility"	Yes
• Send clocks	250 µs, 500 µs, 1 ms
Prioritized startup Accelerated (ASU) and Fast Startup Mode (FSU)	Yes, 8 parallel calls of SFC 12 "D_ACT_DP" per segment possible. Total of maximum 32 ASU and FSU IO devices per PN IO system
Tool change	Yes, 8 parallel calls of SFC 12 "D_ACT_DP" per segment possible. Maximum 32: changing IO devices during operation (partner ports) supported
Changing an IO device without a Micro Memory Card or PG	Yes
3rd interface	
Type of interface	Plug-in interface module
Usable interface module	IF 964-DP
Features	RS 485 / PROFIBUS
Electrically isolated	Yes
Power supply to interface 24 V rated voltage (15 to 30 VDC)	Maximum 150 mA
Number of connection resources	16
Functionality	
PROFIBUS DP	DP master/DP slave
3rd interface DP master mode	
Services	
PG/OP communication	Yes
Routing	Yes
S7 basic communication	Yes
S7 communication	Yes
Constant cycle	Yes
SYNC/FREEZE	Yes
Activate/deactivate DP slaves	Yes
Time synchronization	Yes
Direct data communication (internetwork traffic)	Yes
Transmission rates	Up to 12 Mbps
Number of DP slaves	Maximum 96
Number of slots per interface	Maximum 1632

Address area	Maximum 6 KB inputs / 6 KB outputs
User data per DP slave	Maximum 244 bytes maximum 244 bytes I and maximum 244 bytes O, maximum 244 slots maximum 128 bytes per slot
Note:	
<ul style="list-style-type: none"> • The total sum of the input bytes across all slots may not exceed 244. • The total sum of the output bytes across all slots may not exceed 244. • The address area of the interface (max. 6 KB inputs / 6 KB outputs) may not be exceeded in sum across all 96 slaves. 	
3rd interface DP slave mode	
Specifications as for 1st interface	
Programming	
Programming language	LAD, FBD, STL, SCL, S7 GRAPH, S7 HiGraph
Instruction set	See <i>Instruction List</i>
Nesting levels	7
System functions (SFC)	See <i>Instruction List</i>
Number of simultaneously active SFCs per segment	
• SFC 11 "DPSYC_FR"	2
• SFC 12 "D_ACT_DP"	8
• SFC 59 "RD_REC"	8
• SFC 58 "WR_REC"	8
• SFC 55 "WR_PARM"	8
• SFC 57 "PARM_MOD"	1
• SFC 56 "WR_DPARM"	2
• SFC 13 "DPNRM_DG"	8
• SFC 51 "RDSYSST"	1... 8
• SFC 103 "DP_TOPOL"	1
System function blocks (SFB)	See <i>Instruction List</i>
Number of simultaneously active SFBs	
• SFB 52 "RDREC"	8
• SFB 53 "WRREC"	8
User program protection	Password protection
Access to consistent data in the process image	Yes
CiR synchronization time	
Base load	100 ms
Time per I/O byte	15 µs

10.5 Specifications of the CPU 414-3 PN/DP (6ES7414-3EM05-0AB0)

Isochronous mode	
User data per isochronous slave	Maximum 244 bytes
Maximum number of bytes and slaves in a process image partition	The following must apply: number of bytes/100 + number of slaves < 26
Constant bus cycle time	Yes
Shortest clock pulse	1.0 ms 0.5 ms without use of SFC 126, 127
Longest clock pulse	32 ms
See <i>Isochronous Mode</i> manual	
Dimensions	
Mounting dimensions WxHxD (mm)	50x290x219
Slots required	2
Weight	Approx. 0.9 kg
Voltages, currents	
Current consumption from the S7-400 bus (5 VDC)	Typically 1.2 A Maximum 1.4 A
Current consumption from S7-400 bus (24 VDC) The CPU does not consume any current at 24 V, it only makes this voltage available at the MPI/DP interface.	Total current consumption of the components connected to the MPI/DP interfaces, with a maximum of 150 mA per interface
Backup current	Typically 125 µA (up to 40° C) Maximum 550 µA
Maximum backup time	See <i>Module Specifications</i> reference manual, Section 3.3.
Supply of external backup voltage to CPU	5 to 15 VDC
Power loss	Typ. 6.0 W

10.6 Specifications for the CPU 416-2 (6ES7416-2XN05-0AB0), CPU 416F-2 (6ES7416-2FN05-0AB0)

Data

CPU and firmware version	
MLFB	6ES7416-2XN05-0AB0 6ES7416-2FN05-0AB0
• Firmware version	V 5.3
Associated programming package	as of STEP 7 V 5.3 SP2 + hardware update see also Introduction (Page 11)
Memory	
Work memory	
• Integrated	2.8 MB for code 2.8 MB for data
Load memory	
• Integrated	1 MB RAM
• Expandable FEPR0M	With memory card (FLASH) up to 64 MB
• Expandable RAM	With memory card (RAM) up to 64 MB
Backup with battery	Yes, all data
Typical processing times	
Processing times of	
• Bit operations	30 ns
• Word operations	30 ns
• Fixed-point arithmetic	30 ns
• Floating-point arithmetic	90 ns
Timers/counters and their retentivity	
S7 counters	2048
• Retentivity programmable	From C 0 to C 2047
• Default	From C 0 to C 7
• Counting range	0 to 999
IEC counters	Yes
• Type	SFB
S7 timers	2048
• Retentivity programmable	From T 0 to T 2047
• Default	No retentive timers
• Time range	10 ms to 9990 s
IEC timers	Yes
• Type	SFB

10.6 Specifications for the CPU 416-2 (6ES7416-2XN05-0AB0), CPU 416F-2 (6ES7416-2FN05-0AB0)

Data areas and their retentivity	
Total retentive data area (including bit memories, timers, counters)	Total work and load memory (with backup battery)
Bit memory	16 KB
• Retentivity programmable	From MB 0 to MB 16383
• Default retentive address areas	From MB 0 to MB 15
Clock flag bits	8 (1 flag byte)
Data blocks	Maximum 10000 (DB 0 reserved) Band of numbers 1 - 16000
• Size	Maximum 64 KB
Local data (programmable)	Maximum 32 KB
• Default	16 KB
Blocks	
OBs	See <i>Instruction List</i>
• Size	Maximum 64 KB
Nesting depth	
• Per priority class	24
• Additionally within an error OB	2
FBs	Maximum 5000 Band of numbers 0 - 7999
• Size	Maximum 64 KB
FCs	Maximum 5000 Band of numbers 0 - 7999
• Size	Maximum 64 KB
SDBs	2048
Address areas (I/O)	
Total I/O address area	16 KB / 16 KB including diagnostics addresses, addresses for I/O interface modules, etc
Distributed of this	
• MPI/DP interface	2 KB / 2 KB
• DP interface	8 KB / 8 KB
Process image	16 KB / 16 KB (programmable)
• Default	512 bytes / 512 bytes
• Number of process image partitions	Maximum 15
Consistent data	Maximum 244 bytes
Digital channels	Maximum 131072 / maximum 131072
• Of those are central	Maximum 131072 / maximum 131072
Analog channels	Maximum 8192 / maximum 8192
• Of those are central	Maximum 8192 / maximum 8192

Configuration	
Central racks/expansion units	Maximum 1/21
Multicomputing	Maximum 4 CPUs with UR1 or UR2 maximum 2 CPUs with CR3
Number of plug-in IMs (total)	Maximum 6
• IM 460	Maximum 6
• IM 463-2	Maximum 4
Number of DP masters	
• Integrated	2
• Via IM 467	Maximum 4
• Via CP 443-5 Extended	Maximum 10
IM 467 cannot be used with the CP 443-5 Extended IM 467 cannot be used with the CP 443-1 EX4x in PN IO mode	
Number of PN IO controllers	
• Via CP 443-1 in PN IO mode	Maximum 4 in central rack, see manual for CP 443-1, no combined operation of CP 443-1 EX40 and CP 443-1 EX41/EX20/GX20
Number of plug-in S5 modules via adapter casing (in the central rack)	Maximum 6
Operable function modules and communication processors	
• FM	Limited by the number of slots and the number of connections
• CP 440	Limited by the number of slots
• CP 441	Limited by the number of connections
• PROFIBUS and Ethernet CPs including CP 443-5 Extended and IM 467	Maximum 14 No more than 10 of which may be CPs or IMs as DP master, up to 4 PN IO controllers
Time	
Clock	Yes
• Buffered	Yes
• Resolution	1 ms
• Accuracy after POWER OFF	Maximum deviation per day 1.7 s
• Accuracy after POWER ON	Maximum deviation per day 8.6 s
Operating hours counter	16
• Number	0 to 15
• Value range	0 to 32767 hours 0 to 2 ³¹ -1 hours when SFC 101 is used
• Granularity	1 hour
• Retentive	Yes
Time synchronization	Yes
• In PLC, on MPI and DP	As master or slave

10.6 Specifications for the CPU 416-2 (6ES7416-2XN05-0AB0), CPU 416F-2 (6ES7416-2FN05-0AB0)

Time difference in the system with synchronization via MPI	Maximum 200 ms
S7 message functions	
Number of stations that can log on for message functions (e.g. WIN CC or SIMATIC OP)	Maximum 12 with ALARM_8 or ALARM_P (WinCC); up to 63 with ALARM_S or ALARM_D (OPs)
Symbol-related messages	Yes
<ul style="list-style-type: none"> • Number of messages <li style="padding-left: 20px;">Total <li style="padding-left: 20px;">100 ms interval <li style="padding-left: 20px;">500 ms interval <li style="padding-left: 20px;">1000 ms interval 	Maximum 1024 Maximum 128 Maximum 512 Maximum 1024
<ul style="list-style-type: none"> • Number of auxiliary values per message <li style="padding-left: 20px;">With 100 ms interval <li style="padding-left: 20px;">With 500, 1000 ms interval 	Maximum 1 Maximum 10
Block-related messages	Yes
<ul style="list-style-type: none"> • Simultaneously active ALARM_S/SQ blocks and ALARM_D/DQ blocks 	Maximum 1000
ALARM_8 blocks	Yes
<ul style="list-style-type: none"> • Number of communication jobs for ALARM_8 blocks and blocks for S7 communication (programmable) 	Maximum 4000
<ul style="list-style-type: none"> • Default 	600
Process control messages	Yes
Number of archives that can log on simultaneously (SFB 37 AR_SEND)	32
Test and startup functions	
Status/modify variable	Yes, maximum 16 variable tables
<ul style="list-style-type: none"> • Variable 	Inputs/outputs, bit memories, DB, distributed I/O, timers, counters
<ul style="list-style-type: none"> • Number of variables 	Maximum 70
Force	Yes
<ul style="list-style-type: none"> • Variable 	Inputs/outputs, bit memories, distributed I/O
<ul style="list-style-type: none"> • Number of variables 	Maximum 512
Status block	Yes, maximum 2 blocks at the same time
Single-step	Yes
Number of breakpoints	4
Diagnostic buffer	Yes
<ul style="list-style-type: none"> • Number of entries 	Maximum 3200 (programmable)
<ul style="list-style-type: none"> • Default 	120
Cyclic interrupts	
Value range	500 µs to 60000 ms

Communication	
PG/OP communication	Yes
Number of connectable OPs	63 without message processing
Number of connection resources for S7 connections via all interfaces and CPs	64, with one each of those reserved for programming device and OP
Global data communication	Yes
<ul style="list-style-type: none"> Number of GD circuits 	Maximum 16
<ul style="list-style-type: none"> Number of GD packets Sender Receiver 	Maximum 16 Maximum 32
<ul style="list-style-type: none"> Size of GD packets Consistent of this 	Maximum 54 bytes 1 variable
S7 basic communication	Yes
<ul style="list-style-type: none"> MPI Mode 	Via SFC X_SEND, X_RCV, X_GET and X_PUT
<ul style="list-style-type: none"> DP Master Mode 	Via SFC I_GET and I_PUT
<ul style="list-style-type: none"> User data per job Consistent of this 	Maximum 76 bytes 1 variable
S7 communication	Yes
<ul style="list-style-type: none"> User data per job Consistent of this 	Maximum 64 KB 1 variable (462 bytes)
S5-compatible communication	Via FC AG_SEND and AG_RECV, max. via 10 CP 443-1 or 443-5)
<ul style="list-style-type: none"> User data per job Consistent of this 	Maximum 8 KB 240 bytes
<ul style="list-style-type: none"> Number of simultaneous AG-SEND/AG-RECV jobs per CPU, maximum 	64/64
Standard communication (FMS)	Yes (via CP and loadable FB)
Open IE communication	ISO on TCP via CP 443-1 and downloadable FBs
<ul style="list-style-type: none"> Maximum data length 	1452 bytes
Interfaces	
1st interface	
Type of interface	Integrated
Features	RS 485 / PROFIBUS
Electrically isolated	Yes
Power supply to interface 24 V rated voltage (15 to 30 VDC)	Maximum 150 mA
Number of connection resources	MPI: 44 DP: 32 a diagnostic repeater in the line reduces the number of connection resources on the line by 1
Functionality	
MPI	Yes
PROFIBUS DP	DP master/DP slave

10.6 Specifications for the CPU 416-2 (6ES7416-2XN05-0AB0), CPU 416F-2 (6ES7416-2FN05-0AB0)

1st interface MPI mode	
Services	
PG/OP communication	Yes
Routing	Yes
Global data communication	Yes
S7 basic communication	Yes
S7 communication	Yes
Time synchronization	Yes
Transmission rates	Up to 12 Mbps
1st interface DP master mode	
Services	
PG/OP communication	Yes
Routing	Yes
S7 basic communication	Yes
S7 communication	Yes
Constant cycle	Yes
SYNC/FREEZE	Yes
Activate/deactivate DP slaves	Yes
Time synchronization	Yes
Direct data communication (internetwork traffic)	Yes
Transmission rates	Up to 12 Mbps
Number of DP slaves	Maximum 32
Number of slots per interface	Maximum 544
Address area	Maximum 2 KB inputs / 2 KB outputs
User data per DP slave	Maximum 244 bytes maximum 244 bytes I and maximum 244 bytes O, maximum 244 slots maximum 128 bytes per slot
Note:	
<ul style="list-style-type: none"> • The total sum of the input bytes across all slots may not exceed 244. • The total sum of the output bytes across all slots may not exceed 244. • The address range of the interface (maximum 2 KB inputs / 2 KB outputs) must not be exceeded in total across all 32 slaves. 	
1st interface DP slave mode	
You can only configure the CPU once as a DP slave even if the CPU has several interfaces.	
Service	
Status/modify	Yes
Programming	Yes
Routing	Yes
Time synchronization	Yes
GSD file (http://support.automation.siemens.com/WW/view/en/113652)	
Transmission rate	Up to 12 Mbps
Transfer memory	244 bytes inputs / 244 bytes outputs
Virtual slots	Maximum 32
User data per address area	Maximum 32 bytes
Consistent of this	32 bytes

2nd interface	
Type of interface	Integrated
Features	RS 485 / PROFIBUS
Electrically isolated	Yes
Power supply to interface 24 V rated voltage (15 to 30 VDC)	Maximum 150 mA
Number of connection resources	32 a diagnostic repeater in the line reduces the number of connection resources on the line by 1
Functionality	
PROFIBUS DP	DP master/DP slave
2nd interface DP master mode	
Services	
PG/OP communication	Yes
Routing	Yes
S7 basic communication	Yes
S7 communication	Yes
Constant cycle	Yes
SYNC/FREEZE	Yes
Activate/deactivate DP slaves	Yes
Time synchronization	Yes
Direct data communication (internetwork traffic)	Yes
Transmission rates	Up to 12 Mbps
Number of DP slaves	Maximum 125
Number of slots per interface	Maximum 2173
Address area	Maximum 8 KB inputs / 8 KB outputs
User data per DP slave	Maximum 244 bytes maximum 244 bytes I and maximum 244 bytes O, maximum 244 slots maximum 128 bytes per slot
Note:	
<ul style="list-style-type: none"> • The total sum of the input bytes across all slots may not exceed 244. • The total sum of the output bytes across all slots may not exceed 244. • The address area of the interface (maximum 8 KB inputs / 8 KB outputs) may not be exceeded in sum across all 125 slaves. 	
2nd interface DP slave mode	
Specifications as for 1st interface	
Programming	
Programming language	LAD, FBD, STL, SCL, S7 GRAPH, S7 HiGraph
Instruction set	See <i>Instruction List</i>
Nesting levels	7
System functions (SFC)	See <i>Instruction List</i>
Number of simultaneously active SFCs	
• SFC 11 "DPSYC_FR"	2
• SFC 12 "D_ACT_DP"	8
• SFC 59 "RD_REC"	8
• SFC 58 "WR_REC"	8

10.6 Specifications for the CPU 416-2 (6ES7416-2XN05-0AB0), CPU 416F-2 (6ES7416-2FN05-0AB0)

• SFC 55 "WR_PARM"	8
• SFC 57 "PARM_MOD"	1
• SFC 56 "WR_DPARM"	2
• SFC 13 "DPNRM_DG"	8
• SFC 51 "RDSYSST"	1... 8
• SFC 103 "DP_TOPOL"	1
System function blocks (SFB)	See <i>Instruction List</i>
Number of simultaneously active SFBs	
• SFB 52 "RDREC"	8
• SFB 53 "WRREC"	8
User program protection	Password protection
Access to consistent data in the process image	Yes
CiR synchronization time	
Base load	100 ms
Time per I/O byte	10 µs
Isochronous mode	
User data per isochronous slave	Maximum 244 bytes
Maximum number of bytes and slaves in a process image partition	The following must apply: number of bytes/100 + number of slaves < 40
Constant bus cycle time	Yes
Shortest clock pulse	1 ms 0.5 ms without use of SFC 126, 127
Longest clock pulse	32 ms
See <i>Isochronous Mode</i> manual	
Dimensions	
Mounting dimensions WxHxD (mm)	25x290x219
Slots required	1
Weight	Approx. 0.72 kg
Voltages, currents	
Current consumption from the S7-400 bus (5 VDC)	Typically 0.9 A Maximum 1.1 A
Current consumption from S7-400 bus (24 VDC) The CPU does not consume any current at 24 V, it only makes this voltage available at the MPI/DP interface.	Total current consumption of the components connected to the MPI/DP interfaces, with a maximum of 150 mA per interface
Backup current	Typically 125 µA (up to 40° C) Maximum 550 µA
Maximum backup time	See <i>Module Specifications</i> reference manual, Section 3.3.
Supply of external backup voltage to CPU	5 to 15 VDC
Power loss	Typically 4.5 W

10.7 Specifications of the CPU 416-3 (6ES7416-3XR05-0AB0)

Data

CPU and firmware version	
MLFB	6ES7416-3XR05-0AB0
<ul style="list-style-type: none"> Firmware version 	V 5.3
Associated programming package	as of STEP 7 V 5.3 SP2 + hardware update see also Introduction (Page 11)
Memory	
Work memory	
<ul style="list-style-type: none"> Integrated 	5.6 MB for code 5.6 MB for data
Load memory	
<ul style="list-style-type: none"> Integrated 	1.0 MB RAM
<ul style="list-style-type: none"> Expandable FEPR0M 	With memory card (FLASH) up to 64 MB
<ul style="list-style-type: none"> Expandable RAM 	With memory card (RAM) up to 64 MB
Backup with battery	Yes, all data
Typical processing times	
Processing times of	
<ul style="list-style-type: none"> Bit operations 	30 ns
<ul style="list-style-type: none"> Word operations 	30 ns
<ul style="list-style-type: none"> Fixed-point arithmetic 	30 ns
<ul style="list-style-type: none"> Floating-point arithmetic 	90 ns
Timers/counters and their retentivity	
S7 counters	2048
<ul style="list-style-type: none"> Retentivity programmable 	From C 0 to C 2047
<ul style="list-style-type: none"> Default 	From C 0 to C 7
<ul style="list-style-type: none"> Counting range 	0 to 999
IEC counters	Yes
<ul style="list-style-type: none"> Type 	SFB
S7 timers	2048
<ul style="list-style-type: none"> Retentivity programmable 	From T 0 to T 2047
<ul style="list-style-type: none"> Default 	No retentive timers
<ul style="list-style-type: none"> Time range 	10 ms to 9990 s
IEC timers	Yes
<ul style="list-style-type: none"> Type 	SFB

10.7 Specifications of the CPU 416-3 (6ES7416-3XR05-0AB0)

Data areas and their retentivity	
Total retentive data area (including bit memories, timers, counters)	Total work and load memory (with backup battery)
Bit memory	16 KB
• Retentivity programmable	From MB 0 to MB 16383
• Default retentive address areas	From MB 0 to MB 15
Clock flag bits	8 (1 flag byte)
Data blocks	Maximum 10000 (DB 0 reserved) Band of numbers 1 - 16000
• Size	Maximum 64 KB
Local data (programmable)	Maximum 32 KB
• Default	16 KB
Blocks	
OBs	See <i>Instruction List</i>
• Size	Maximum 64 KB
Nesting depth	
• Per priority class	24
• Additionally within an error OB	2
FBs	Maximum 5000 Band of numbers 0 - 7999
• Size	Maximum 64 KB
FCs	Maximum 5000 Band of numbers 0 - 7999
• Size	Maximum 64 KB
SDBs	Maximum 2048
Address areas (I/O)	
Total I/O address area	16 KB / 16 KB including diagnostics addresses, addresses for I/O interface modules, etc
Distributed of this	
• MPI/DP interface	2 KB / 2 KB
• DP interface	8 KB / 8 KB
Process image	16 KB / 16 KB (programmable)
• Default	512 bytes / 512 bytes
• Number of process image partitions	Maximum 15
Consistent data	Maximum 244 bytes
Digital channels	Maximum 131072 / maximum 131072
• Of those are central	Maximum 131072 / maximum 131072
Analog channels	Maximum 8192 / maximum 8192
• Of those are central	Maximum 8192 / maximum 8192

10.7 Specifications of the CPU 416-3 (6ES7416-3XR05-0AB0)

Configuration	
Central racks/expansion units	Maximum 1/21
Multicomputing	Maximum 4 CPUs with UR1 or UR2 maximum 2 CPUs with CR3
Number of plug-in IMs (total)	Maximum 6
• IM 460	Maximum 6
• IM 463-2	Maximum 4
Number of DP masters	
• Integrated	2
• Via IF 964-DP	1
• Via IM 467	Maximum 4
• Via CP 443-5 Extended	Maximum 10
IM 467 cannot be used with the CP 443-5 Extended IM 467 cannot be used with the CP 443-1 EX4x in PN IO mode	
Number of PN IO controllers	
• Via CP 443-1 in PN IO mode	Maximum 4 in central rack, see manual for CP 443-1, no combined operation of CP 443-1 EX40 and CP 443-1 EX41/EX20/GX20
Number of plug-in S5 modules via adapter casing (in the central rack)	Maximum 6
Operable FMs and CPs	
• FM	Limited by the number of slots and the number of connections
• CP 440	Limited by the number of slots
• CP 441	Limited by the number of connections
• PROFIBUS and Ethernet CPs including CP 443-5 Extended and IM 467	Maximum 14 No more than 10 of which may be CPs or IMs as DP master, up to 4 PN IO controllers
Time	
Clock	Yes
• Buffered	Yes
• Resolution	1 ms
• Accuracy after POWER OFF	Maximum deviation per day 1.7 s
• Accuracy after POWER ON	Maximum deviation per day 8.6 s
Operating hours counter	16
• Number	0 to 15
• Value range	0 to 32767 hours 0 to 2 ³¹ -1 hours when SFC 101 is used
• Granularity	1 hour
• Retentive	Yes
Time synchronization	Yes
• In PLC, on MPI, DP and IF 964 DP	As master or slave

10.7 Specifications of the CPU 416-3 (6ES7416-3XR05-0AB0)

Time difference in the system with synchronization via MPI	Maximum 200 ms
S7 message functions	
Number of stations that can log on for message functions (e.g. WIN CC or SIMATIC OP)	Maximum 12 with ALARM_8 or ALARM_P (WinCC); up to 63 with ALARM_S or ALARM_D (OPs)
Symbol-related messages	Yes
<ul style="list-style-type: none"> Number of messages Total 100 ms interval 500 ms interval 1000 ms interval 	Maximum 1024 Maximum 128 Maximum 512 Maximum 1024
<ul style="list-style-type: none"> Number of auxiliary values per message With 100 ms interval With 500, 1000 ms interval 	Maximum 1 Maximum 10
Block-related messages	Yes
<ul style="list-style-type: none"> Simultaneously active ALARM_S/SQ blocks and ALARM_D/DQ blocks 	Maximum 1000
ALARM_8 blocks	Yes
<ul style="list-style-type: none"> Number of communication jobs for ALARM_8 blocks and blocks for S7 communication (programmable) 	Maximum 4000
<ul style="list-style-type: none"> Default 	600
Process control messages	Yes
Number of archives that can log on simultaneously (SFB 37 AR_SEND)	32
Test and startup functions	
Status/modify variable	Yes, maximum 16 variable tables
<ul style="list-style-type: none"> Variable 	Inputs/outputs, bit memories, DB, distributed I/O, timers, counters
<ul style="list-style-type: none"> Number of variables 	Maximum 70
Force	Yes
<ul style="list-style-type: none"> Variable 	Inputs/outputs, bit memories, distributed I/O
<ul style="list-style-type: none"> Number of variables 	Maximum 512
Status block	Yes, maximum 2 blocks at the same time
Single-step	Yes
Number of breakpoints	4
Diagnostic buffer	Yes
<ul style="list-style-type: none"> Number of entries 	Maximum 3200 (programmable)
<ul style="list-style-type: none"> Default 	120
Cyclic interrupts	
Value range	500 µs to 60000 ms

Communication	
PG/OP communication	Yes
Number of connectable OPs	63
Number of connection resources for S7 connections via all interfaces and CPs	64, with one each of those reserved for programming device and OP
Global data communication	Yes
<ul style="list-style-type: none"> Number of GD circuits 	Maximum 16
<ul style="list-style-type: none"> Number of GD packets Sender Receiver 	Maximum 16 Maximum 32
<ul style="list-style-type: none"> Size of GD packets Consistent of this 	Maximum 54 bytes 1 variable
S7 basic communication	Yes
<ul style="list-style-type: none"> MPI Mode 	Via SFC X_SEND, X_RCV, X_GET and X_PUT
<ul style="list-style-type: none"> DP Master Mode 	Via SFC I_GET and I_PUT
<ul style="list-style-type: none"> User data per job Consistent of this 	Maximum 76 bytes 1 variable
S7 communication	Yes
<ul style="list-style-type: none"> User data per job Consistent of this 	Maximum 64 KB 1 variable (462 bytes)
S5-compatible communication	Via FC AG_SEND and AG_RECV, max. via 10 CP 443-1 or 443-5)
<ul style="list-style-type: none"> User data per job Consistent of this 	Maximum 8 KB 240 bytes
<ul style="list-style-type: none"> Number of simultaneous AG-SEND/AG-RECV jobs per CPU, maximum 	64/64
Standard communication (FMS)	Yes (via CP and loadable FB)
Open IE communication	ISO on TCP via CP 443-1 and downloadable FBs
<ul style="list-style-type: none"> Maximum data length 	1452 bytes
Interfaces	
1st interface	
Type of interface	Integrated
Features	RS 485 / PROFIBUS
Electrically isolated	Yes
Power supply to interface 24 V rated voltage (15 to 30 VDC)	Maximum 150 mA
Number of connection resources	MPI: 44 DP: 32 a diagnostic repeater in the line reduces the number of connection resources on the line by 1
Functionality	
MPI	Yes
PROFIBUS DP	DP master/DP slave

10.7 Specifications of the CPU 416-3 (6ES7416-3XR05-0AB0)

1st interface MPI mode	
Services	
PG/OP communication	Yes
Routing	Yes
Global data communication	Yes
S7 basic communication	Yes
S7 communication	Yes
Time synchronization	Yes
Transmission rates	Up to 12 Mbps
1st interface DP master mode	
Services	
PG/OP communication	Yes
Routing	Yes
S7 basic communication	Yes
S7 communication	Yes
Constant cycle	Yes
SYNC/FREEZE	Yes
Activate/deactivate DP slaves	Yes
Time synchronization	Yes
Direct data communication (internetwork traffic)	Yes
Transmission rates	Up to 12 Mbps
Number of DP slaves	Maximum 32
Number of slots per interface	Maximum 544
Address area	Maximum 2 KB inputs / 2 KB outputs
User data per DP slave	Maximum 244 bytes maximum 244 bytes I and maximum 244 bytes O, maximum 244 slots maximum 128 bytes per slot
Note:	
<ul style="list-style-type: none"> • The total sum of the input bytes across all slots may not exceed 244. • The total sum of the output bytes across all slots may not exceed 244. • The address range of the interface (maximum 2 KB inputs / 2 KB outputs) must not be exceeded in total across all 32 slaves. 	
1st interface DP slave mode	
You can only configure the CPU once as a DP slave even if the CPU has several interfaces.	
Service	
Status/modify	Yes
Programming	Yes
Routing	Yes
Time synchronization	Yes
GSD file (http://support.automation.siemens.com/WW/view/en/113652)	
Transmission rate	Up to 12 Mbps
Transfer memory	244 bytes inputs / 244 bytes outputs
Virtual slots	Maximum 32
User data per address area	Maximum 32 bytes
Consistent of this	32 bytes

2nd interface	
Type of interface	Integrated
Features	RS 485 / PROFIBUS
Electrically isolated	Yes
Power supply to interface 24 V rated voltage (15 to 30 VDC)	Maximum 150 mA
Number of connection resources	32, a diagnostics repeater in the segment reduces the number of connection resources on the segment by the count of 1
Functionality	
<ul style="list-style-type: none"> PROFIBUS DP 	DP master/DP slave
2nd interface DP master mode	
Services	
PG/OP communication	Yes
Routing	Yes
S7 basic communication	Yes
S7 communication	Yes
Constant cycle	Yes
SYNC/FREEZE	Yes
Activate/deactivate DP slaves	Yes
Time synchronization	Yes
Direct data communication (internetwork traffic)	Yes
Transmission rates	Up to 12 Mbps
Number of DP slaves	Maximum 125
Number of slots per interface	Maximum 2173
Address area	Maximum 8 KB inputs / 8 KB outputs
User data per DP slave	Maximum 244 bytes maximum 244 bytes I and maximum 244 bytes O, maximum 244 slots maximum 128 bytes per slot
Note:	
<ul style="list-style-type: none"> The total sum of the input bytes across all slots may not exceed 244. The total sum of the output bytes across all slots may not exceed 244. The address area of the interface (maximum 8 KB inputs / 8 KB outputs) may not be exceeded in sum across all 125 slaves. 	
2nd interface DP slave mode	
Specifications as for 1st interface	
3rd interface	
Type of interface	Plug-in interface module
Usable interface module	IF 964-DP
Technical features as for the 2nd interface	

10.7 Specifications of the CPU 416-3 (6ES7416-3XR05-0AB0)

Programming	
Programming language	LAD, FBD, STL, SCL, S7 GRAPH, S7 HiGraph
Instruction set	See <i>Instruction List</i>
Nesting levels	7
System functions (SFC)	See <i>Instruction List</i>
Number of simultaneously active SFCs per segment	
• SFC 11 "DPSYC_FR"	2
• SFC 12 "D_ACT_DP"	8
• SFC 59 "RD_REC"	8
• SFC 58 "WR_REC"	8
• SFC 55 "WR_PARM"	8
• SFC 57 "PARM_MOD"	1
• SFC 56 "WR_DPARM"	2
• SFC 13 "DPNRM_DG"	8
• SFC 51 "RDSYSST"	1... 8
• SFC 103 "DP_TOPOL"	1
System function blocks (SFB)	See <i>Instruction List</i>
Number of simultaneously active SFBs	
• SFB 52 "RDREC"	8
• SFB 53 "WRREC"	8
User program protection	Password protection
Access to consistent data in the process image	Yes
CiR synchronization time	
Base load	100 ms
Time per I/O byte	10 µs
Isochronous mode	
User data per isochronous slave	Maximum 244 bytes
Maximum number of bytes and slaves in a process image partition	The following must apply: number of bytes/100 + number of slaves < 40
Constant bus cycle time	Yes
Shortest clock pulse	1 ms 0.5 ms without use of SFC 126, 127
Longest clock pulse	32 ms
See <i>Isochronous Mode</i> manual	
Dimensions	
Mounting dimensions WxHxD (mm)	50x290x219
Slots required	2
Weight	Approx. 0.88 kg

10.7 Specifications of the CPU 416-3 (6ES7416-3XR05-0AB0)

Voltages, currents	
Current consumption from the S7-400 bus (5 VDC)	Typically 1.1 A Maximum 1.3 A
Current consumption from S7-400 bus (24 VDC) The CPU does not consume any current at 24 V, it only makes this voltage available at the MPI/DP interface.	Total current consumption of the components connected to the MPI/DP interfaces, with a maximum of 150 mA per interface
Backup current	Typically 125 µA (up to 40° C) Maximum 550 µA
Maximum backup time	See <i>Module Specifications</i> reference manual, Section 3.3.
Supply of external backup voltage to CPU	5 to 15 VDC
Power loss	Typically 5.5 W

10.8 Specifications of the CPU 416-3 PN/DP (6ES7416-3ER05-0AB0), CPU 416F-3 PN/DP (6ES7416-3FR05-0AB0)

Data

CPU and firmware version	
MLFB	6ES7416-3ER05-0AB0 6ES7416-3FR05-0AB0
• Firmware version	V 5.3
Associated programming package	As of STEP 7 V 5.4 SP4 + hardware update see also Introduction (Page 11)
Memory	
Work memory	
• Integrated	5.6 MB for code 5.6 MB for data
Load memory	
• Integrated	1024 KB RAM
• Expandable FEPR0M	With memory card (FLASH) up to 64 MB
• Expandable RAM	With memory card (RAM) up to 64 MB
Backup with battery	Yes, all data
Typical processing times	
Processing times of	
• Bit operations	30 ns
• Word operations	30 ns
• Fixed-point arithmetic	30 ns
• Floating-point arithmetic	90 ns
Timers/counters and their retentivity	
S7 counters	2048
• Retentivity programmable	From C 0 to C 2047
• Default	From C 0 to C 7
• Counting range	0 to 999
IEC counters	Yes
• Type	SFB
S7 timers	2048
• Retentivity programmable	From T 0 to T 2047
• Default	No retentive timers
• Time range	10 ms to 9990 s
IEC timers	Yes
• Type	SFB

10.8 Specifications of the CPU 416-3 PN/DP (6ES7416-3ER05-0AB0), CPU 416F-3 PN/DP (6ES7416-3FR05-0AB0)

Data areas and their retentivity	
Total retentive data area (including bit memories, timers, counters)	Total work and load memory (with backup battery)
Bit memory	16 KB
<ul style="list-style-type: none"> Retentivity programmable 	From MB 0 to MB 16383
<ul style="list-style-type: none"> Default retentive address areas 	From MB 0 to MB 15
Clock flag bits	8 (1 flag byte)
Data blocks	Maximum 10000 (DB 0 reserved) Band of numbers 1 to 16 000
<ul style="list-style-type: none"> Size 	Maximum 64 KB
Local data (programmable)	Maximum 32 KB
<ul style="list-style-type: none"> Default 	16 KB
Blocks	
OBs	See <i>Instruction List</i>
<ul style="list-style-type: none"> Size 	Maximum 64 KB
Nesting depth	
<ul style="list-style-type: none"> Per priority class 	24
<ul style="list-style-type: none"> Additionally within an error OB 	2
FBs	Maximum 5000 Band of numbers 0 - 7999
<ul style="list-style-type: none"> Size 	Maximum 64 KB
FCs	Maximum 5000 Band of numbers 0 - 7999
<ul style="list-style-type: none"> Size 	Maximum 64 KB
SDBs	Maximum 2048
Address areas (I/O)	
Total I/O address area	16 KB / 16 KB including diagnostics addresses, addresses for I/O interface modules, etc
Distributed of this	
<ul style="list-style-type: none"> MPI/DP interface 	2 KB / 2 KB
<ul style="list-style-type: none"> DP interface 	8 KB / 8 KB
<ul style="list-style-type: none"> PN interface 	8 KB / 8 KB
Process image	16 KB / 16 KB (programmable)
<ul style="list-style-type: none"> Default 	512 bytes / 512 bytes
<ul style="list-style-type: none"> Number of process image partitions 	Maximum 15
Consistent data	Maximum 244 bytes
Digital channels	Maximum 131072 / maximum 131072
<ul style="list-style-type: none"> Of those are central 	Maximum 131072 / maximum 131072
Analog channels	Maximum 8192 / maximum 8192
<ul style="list-style-type: none"> Of those are central 	Maximum 8192 / maximum 8192

10.8 Specifications of the CPU 416-3 PN/DP (6ES7416-3ER05-0AB0), CPU 416F-3 PN/DP (6ES7416-3FR05-0AB0)

Configuration	
Central racks/expansion units	Maximum 1/21
Multicomputing	Maximum 4 CPUs with UR1 or UR2 maximum 2 CPUs with CR3
Number of plug-in IMs (total)	Maximum 6
• IM 460	Maximum 6
• IM 463-2	Maximum 4
Number of DP masters	
• Integrated	1
• Via IF 964-DP	1
• Via IM 467	Maximum 4
• Via CP 443-5 Extended	Maximum 10
IM 467 cannot be used with the CP 443-5 Extended IM 467 cannot be used with the CP 443-1 EX4x in PN IO mode	
Number of PN IO controllers	
• Integrated	1
• Via CP 443-1 in PN IO mode	Maximum 4 in central rack, see manual for CP 443-1, no combined operation of CP 443-1 EX40 and CP 443-1 EX41/EX20/GX20
Number of plug-in S5 modules via adapter casing (in the central rack)	Maximum 6
Operable FMs and CPs	
• FM	Limited by the number of slots and the number of connections
• CP 440	Limited by the number of slots
• CP 441	Limited by the number of connections
• PROFIBUS and Ethernet CPs including CP 443-5 Extended and IM 467	Maximum 14
Time	
Clock	Yes
• Buffered	Yes
• Resolution	1 ms
• Accuracy after POWER OFF	Maximum deviation per day 1.7 s
• Accuracy after POWER ON	Maximum deviation per day 8.6 s
Operating hours counter	16
• Number	0 to 15
• Value range	0 to 32767 hours 0 to $2^{31} - 1$ hours when SFC 101 is used
• Granularity	1 hour
• Retentive	Yes
Time synchronization	Yes

10.8 Specifications of the CPU 416-3 PN/DP (6ES7416-3ER05-0AB0), CPU 416F-3 PN/DP (6ES7416-3FR05-0AB0)

• In PLC, on MPI, DP and IF 964 DP	As master or slave
• On Ethernet via NTP	As client
Time difference in the system with synchronization via MPI	Maximum 200 ms
S7 message functions	
Number of stations that can be used	
For block-specific messages (Alarm_S/SQ or Alarm_D/DQ)	63
For control-specific messages (ALARM_8 blocks, archive)	12
Symbol-related messages	Yes
• Number of messages Total 100 ms interval 500 ms interval 1000 ms interval	Maximum 1024 Maximum 128 Maximum 512 Maximum 1024
• Number of auxiliary values per message With 100 ms interval With 500, 1000 ms interval	Maximum 1 Maximum 10
Block-related messages	Yes
• Simultaneously active ALARM_S/SQ blocks and ALARM_D/DQ blocks	Maximum 1000
ALARM_8 blocks	Yes
• Number of communication jobs for ALARM_8 blocks and blocks for S7 communication (programmable)	Maximum 4000
• Default	600
Process control messages	Yes
Number of archives that can log on simultaneously (SFB 37 AR_SEND)	32
Test and startup functions	
Status/modify variable	Yes, maximum 16 variable tables
• Variable	Inputs/outputs, bit memories, DB, distributed I/O, timers, counters
• Number of variables	Maximum 70
Force	Yes
• Variable	Inputs/outputs, bit memories, distributed I/O
• Number of variables	Maximum 512
Status block	Yes, maximum 2 blocks at the same time
Single-step	Yes
Diagnostic buffer	Yes
• Number of entries	Maximum 3200 (programmable)
• Default	120
Number of breakpoints	4

10.8 Specifications of the CPU 416-3 PN/DP (6ES7416-3ER05-0AB0), CPU 416F-3 PN/DP (6ES7416-3FR05-0AB0)

Cyclic interrupts	
Value range	500 µs to 60000 ms
Communication	
PG/OP communication	Yes
Number of connectable OPs	63 without message processing
Number of connection resources for S7 connections via all interfaces and CPs	64, with one each of those reserved for programming device and OP
Global data communication	Yes
• Number of GD circuits	Maximum 16
• Number of GD packets Sender Receiver	Maximum 16 Maximum 32
• Size of GD packets Consistent of this	Maximum 54 bytes 1 variable
S7 basic communication	Yes
• MPI Mode	Via SFC X_SEND, X_RCV, X_GET and X_PUT
• DP Master Mode	Via SFC I_GET and I_PUT
• User data per job Consistent of this	Maximum 76 bytes 1 variable
S7 communication	Yes
• User data per job Consistent of this	Maximum 64 KB 1 variable (462 bytes)
S5-compatible communication	Via FC AG_SEND and AG_RECV, max. via 10 CP 443-1 or 443-5)
• User data per job Consistent of this	Maximum 8 KB 240 bytes
• Number of simultaneous AG-SEND/AG-RECV jobs per CPU, maximum	64/64
Standard communication (FMS)	ISO on TCP via CP 443-1 and downloadable blocks
Web server	Yes
• Number of http clients	5
• Variable tables	Maximum 50, each with maximum 200 variables
• Variable status	Of max. 50 variables
• Messages	Per language max. 400 message texts with a total size of 512 KB

10.8 Specifications of the CPU 416-3 PN/DP (6ES7416-3ER05-0AB0), CPU 416F-3 PN/DP (6ES7416-3FR05-0AB0)

Open IE communication via TCP/IP	
Number of connections / access points, total	Maximum 62
Possible Port Numbers	1 to 49151
Where parameters are assigned without specification of a port number, the system assigns a port from the dynamic port number range between 49152 and 65534	
Reserved Port Numbers	TCP 20, 21 FTP TCP 25 SMTP TCP 80 HTTP TCP 102 RFC1006 UDP 135 RPC-DCOM UDP 161 SNMP_REQUEST UDP 34964 PN IO UDP 65532 NTP UDP 65533 NTP UDP 65534 NTP UDP 65535 NT
TCP/IP	Yes, via integrated PROFINET interface and loadable FBs
<ul style="list-style-type: none"> Maximum number of connections 	62
<ul style="list-style-type: none"> Data length, max. 	32767 bytes
ISO on TCP	Yes (via integrated PROFINET interface or CP 443-1 EX 40/EX 41/EX 20/GX 20 and loadable blocks)
<ul style="list-style-type: none"> Maximum number of connections 	62
<ul style="list-style-type: none"> Maximum data length via integrated PROFINET interface 	32767 bytes
<ul style="list-style-type: none"> Maximum data length via CP 443-1 	1452 bytes
UDP	Yes, via integrated PROFINET interface and loadable FBs
<ul style="list-style-type: none"> Maximum number of connections 	62
<ul style="list-style-type: none"> Data length, max. 	1472 bytes
PROFINET CBA	
Reference setting for the CPU communication load	20%
Number of remote interconnecting partners	32
Number of master/slave functions	150
Total of all master/slave connections	6000
Data length of all incoming master/slave connections, max.	65000 bytes
Data length of all outgoing master/slave connections, max.	65000 bytes
Number of device-internal and PROFIBUS interconnections	1000
Data length of the device-internal and PROFIBUS interconnections, max.	16000 bytes
Data length per connection, max.	2000 bytes
Remote interconnections with acyclic transmission	

10.8 Specifications of the CPU 416-3 PN/DP (6ES7416-3ER05-0AB0), CPU 416F-3 PN/DP (6ES7416-3FR05-0AB0)

• Scan rate: Scan interval, min.	200 ms
• Number of incoming interconnections	500
• Number of outgoing interconnections	500
• Data length of all incoming interconnections, max.	16000 bytes
• Data length of all outgoing interconnections, max.	16000 bytes
• Data length per connection, (acyclic interconnections), max.	2000 bytes
Remote interconnections with cyclic transmission	
• Transmission frequency: Minimum transmission interval	1 ms
• Number of incoming interconnections	300
• Number of outgoing interconnections	300
• Data length of all incoming interconnections, max.	4800 bytes
• Data length of all outgoing interconnections	4800 bytes
• Data length per connection, (acyclic interconnections), max.	250 bytes
HMI variables via PROFINET (acyclic)	
• Update HMI variables	500 ms
• Number of stations that can be logged on for HMI variables (PN OPC/iMAP)	2 x PN OPC / 1 x iMap
• Number of HMI variables	1500
• Data length of all HMI variables, max.	48000 bytes
PROFIBUS proxy functionality	
• Supported	Yes
• Number of coupled PROFIBUS devices	32
• Data length per connection, max.	240 bytes (slave dependent)
Interfaces	
1st interface	
Type of interface	Integrated
Features	RS 485 / PROFIBUS
Electrically isolated	Yes
Power supply to interface 24 V rated voltage (15 to 30 VDC)	Maximum 150 mA
Number of connection resources	MPI: 44 DP: 32; a diagnostics repeater in the segment reduces the number of connection resources on the segment by the count of 1
Functionality	
MPI	Yes
PROFIBUS DP	DP master/DP slave

10.8 Specifications of the CPU 416-3 PN/DP (6ES7416-3ER05-0AB0), CPU 416F-3 PN/DP (6ES7416-3FR05-0AB0)

1st interface MPI mode	
Services	
PG/OP communication	Yes
Routing	Yes
Global data communication	Yes
S7 basic communication	Yes
S7 communication	Yes
Time synchronization	Yes
Transmission rates	Up to 12 Mbps
1st interface DP master mode	
Services	
PG/OP communication	Yes
Routing	Yes
S7 basic communication	Yes
S7 communication	Yes
Constant cycle	Yes
SYNC/FREEZE	Yes
Activate/deactivate DP slaves	Yes
Time synchronization	Yes
Direct data communication (internetwork traffic)	Yes
Transmission rates	Up to 12 Mbps
Number of DP slaves	Maximum 32
Number of slots per interface	Maximum 544
Address area	Maximum 2 KB inputs / 2 KB outputs
User data per DP slave	Maximum 244 bytes maximum 244 bytes I and maximum 244 bytes O, maximum 244 slots maximum 128 bytes per slot
Note:	
<ul style="list-style-type: none"> • The total sum of the input bytes across all slots may not exceed 244. • The total sum of the output bytes across all slots may not exceed 244. • The address range of the interface (maximum 2 KB inputs / 2 KB outputs) must not be exceeded in total across all 32 slaves. 	
1st interface DP slave mode	
You can only configure the CPU once as a DP slave even if the CPU has several interfaces.	
Service	
Status/modify	Yes
Programming	Yes
Routing	Yes
Time synchronization	Yes
GSD file (http://support.automation.siemens.com/WW/view/en/113652)	
Transmission rate	Up to 12 Mbps
Transfer memory	244 bytes inputs / 244 bytes outputs
Virtual slots	Maximum 32
User data per address area	Maximum 32 bytes
Consistent of this	32 bytes

10.8 Specifications of the CPU 416-3 PN/DP (6ES7416-3ER05-0AB0), CPU 416F-3 PN/DP (6ES7416-3FR05-0AB0)

2nd interface	
Type of interface	Integrated
Features	Ethernet 2-port switch 2 x RJ45
Electrically isolated	Yes
Autosensing (10/100 Mbps)	Yes
Autonegotiation	Yes
Autocrossover	Yes
Functionality	
• PROFINET	Yes
Services	
• PG communication	Yes
• OP communication	Yes
• S7 communication Maximum number of configurable connections Maximum number of instances	Yes 32, with one each of those reserved for programming device and OP 600
• Routing	Yes
• PROFINET IO	Yes
• PROFINET CBA	Yes
Open IE communication	
• Via TCP/IP	Yes
• ISO on TCP	Yes
• UDP	Yes
• Time synchronization	Yes
PROFINET IO	
PNO ID (hexadecimal)	Vendor ID: 0x002A Device ID: 0x0102
Number of PROFINET IO devices that can be connected	256
Address area	Maximum 8 KB inputs/outputs
Number of submodules	Maximum 8192 Mixed modules count twice
Maximum user data length including user data qualifiers	255 bytes per submodule
Maximum user data consistency including user data qualifiers	255 bytes per submodule
Update time	250 μ s, 0.5 ms, 1 ms, 2 ms, 4 ms, 8 ms, 16 ms, 32 ms, 64 ms, 128 ms, 256 ms and 512 ms The minimum value is determined by the set communication portion for PROFINET IO, the number of IO devices and the amount of configured user data.

10.8 Specifications of the CPU 416-3 PN/DP (6ES7416-3ER05-0AB0), CPU 416F-3 PN/DP (6ES7416-3FR05-0AB0)

S7 protocol functions	
• Programming device functions	Yes
• OP functions	Yes
IRT (Isochronous Real Time)	Yes, RT Class 2
• Option "with high flexibility"	Yes
• Send clocks	250 µs, 500 µs, 1 ms,
Prioritized startup Accelerated (ASU) and Fast Startup Mode (FSU)	Yes, total of maximum 32 ASU and FSU IO devices per PN IO system
Note: The Fast Startup function is available only after the relevant IO device was disconnected from the IO controller at least for the duration of six seconds.	
Tool change	Yes, 8 parallel calls of SFC 12 "D_ACT_DP" per segment possible. Maximum 32: changing IO devices during operation (partner ports) supported
Changing an IO device without a Micro Memory Card or PG	Yes
3rd interface	
Type of interface	Plug-in interface module
Usable interface module	IF 964-DP
Features	RS 485 / PROFIBUS
Electrically isolated	Yes
Power supply to interface 24 V rated voltage (15 to 30 VDC)	Maximum 150 mA
Number of connection resources	32, a diagnostics repeater in the segment reduces the number of connection resources on the segment by the count of 1
Functionality	
• PROFIBUS DP	DP master/DP slave
3rd interface DP master mode	
Services	
PG/OP communication	Yes
Routing	Yes
S7 basic communication	Yes
S7 communication	Yes
Constant cycle	Yes
SYNC/FREEZE	Yes
Activate/deactivate DP slaves	Yes
Time synchronization	Yes
Direct data communication (internetwork traffic)	Yes
Transmission rates	Up to 12 Mbps
Number of DP slaves	Maximum 125
Number of slots per interface	Maximum 2173
Address area	Maximum 8 KB inputs / 8 KB outputs

10.8 Specifications of the CPU 416-3 PN/DP (6ES7416-3ER05-0AB0), CPU 416F-3 PN/DP (6ES7416-3FR05-0AB0)

User data per DP slave	Maximum 244 bytes maximum 244 bytes I and maximum 244 bytes O, maximum 244 slots maximum 128 bytes per slot
Note:	
<ul style="list-style-type: none"> • The total sum of the input bytes across all slots may not exceed 244. • The total sum of the output bytes across all slots may not exceed 244. • The address area of the interface (maximum 8 KB inputs / 8 KB outputs) may not be exceeded in sum across all 125 slaves. 	
3rd interface DP slave mode	
Specifications as for 1st interface	
Programming	
Programming language	LAD, FBD, STL, SCL, S7 GRAPH, S7 HiGraph
Instruction set	See <i>Instruction List</i>
Nesting levels	7
System functions (SFC)	See <i>Instruction List</i>
Number of simultaneously active SFCs per segment	
• SFC 11 "DPSYC_FR"	2
• SFC 12 "D_ACT_DP"	8
• SFC 59 "RD_REC"	8
• SFC 58 "WR_REC"	8
• SFC 55 "WR_PARM"	8
• SFC 57 "PARM_MOD"	1
• SFC 56 "WR_DPARM"	2
• SFC 13 "DPNRM_DG"	8
• SFC 51 "RDSYSST"	1...8
• SFC 103 "DP_TOPOL"	1
System function blocks (SFB)	See <i>Instruction List</i>
Number of simultaneously active SFBs	
• SFB 52 "RDREC"	8
• SFB 53 "WRREC"	8
User program protection	Password protection
Access to consistent data in the process image	Yes
CiR synchronization time	
Base load	100 ms
Time per I/O byte	10 µs

10.8 Specifications of the CPU 416-3 PN/DP (6ES7416-3ER05-0AB0), CPU 416F-3 PN/DP (6ES7416-3FR05-0AB0)

Isochronous mode	
User data per isochronous slave	Maximum 244 bytes
Maximum number of bytes and slaves in a process image partition	The following must apply: number of bytes/100 + number of slaves < 40
Constant bus cycle time	Yes
Shortest clock pulse	1 ms 0.5 ms without use of SFC 126, 127
Longest clock pulse	32 ms
See <i>Isochronous Mode</i> manual	
Dimensions	
Mounting dimensions WxHxD (mm)	50x290x219
Slots required	2
Weight	Approx. 0.9 kg
Voltages, currents	
Current consumption from the S7-400 bus (5 VDC)	Typically 1.2 A Maximum 1.4 A
Current consumption from S7-400 bus (24 VDC) The CPU does not consume any current at 24 V, it only makes this voltage available at the MPI/DP interface.	Total current consumption of the components connected to the MPI/DP interfaces, with a maximum of 150 mA per interface
Backup current	Typically 125 µA (up to 40° C) Maximum 550 µA
Maximum backup time	See <i>Module Specifications</i> reference manual, Section 3.3.
Supply of external backup voltage to CPU	5 to 15 VDC
Power loss	Typ. 6.0 W

10.9 Specifications of the CPU 417-4 (6ES7417-4XT05-0AB0)

Data

CPU and firmware version	
MLFB	6ES7417-4XT05-0AB0
• Firmware version	V 5.3
Associated programming package	as of STEP 7 V 5.3 SP2 + hardware update see also Introduction (Page 11)
Memory	
Work memory	
• Integrated	15 MB for code 15 MB for data
Load memory	
• Integrated	1.0 MB RAM
• Expandable FEPR0M	With memory card (FLASH) up to 64 MB
• Expandable RAM	With memory card (RAM) up to 64 MB
Backup with battery	Yes, all data
Typical processing times	
Processing times of	
• Bit operations	18 ns
• Word operations	18 ns
• Fixed-point arithmetic	18 ns
• Floating-point arithmetic	54 ns
Timers/counters and their retentivity	
S7 counters	2048
• Retentivity programmable	From C 0 to C 2047
• Default	From C 0 to C 7
• Counting range	0 to 999
IEC counters	Yes
• Type	SFB
S7 timers	2048
• Retentivity programmable	From T 0 to T 2047
• Default	No retentive timers
• Time range	10 ms to 9990 s
IEC timers	Yes
• Type	SFB
Data areas and their retentivity	
Total retentive data area (including bit memories, timers, counters)	Total work and load memory (with backup battery)

10.9 Specifications of the CPU 417-4 (6ES7417-4XT05-0AB0)

Bit memory	16 KB
• Retentivity programmable	From MB 0 to MB 16383
• Default retentive address areas	From MB 0 to MB 15
Clock flag bits	8 (1 flag byte)
Data blocks	Maximum 16000 (DB 0 reserved) Band of numbers 1 - 16000
• Size	Maximum 64 KB
Local data (programmable)	Maximum 64 KB
• Default	32 KB
Blocks	
OBs	See <i>Instruction List</i>
• Size	Maximum 64 KB
Nesting depth	
• Per priority class	24
• Additionally within an error OB	2
FBs	Maximum 8000, band of numbers 0 - 7999
• Size	Maximum 64 KB
FCs	Maximum 8000, band of numbers 0 - 7999
• Size	Maximum 64 KB
SDBs	Maximum 2048
Address areas (I/O)	
Total I/O address area	16 KB / 16 KB including diagnostics addresses, addresses for I/O interface modules, etc
Distributed of this	
• MPI/DP interface	2 KB / 2 KB
• DP interface	8 KB / 8 KB
Process image	16 KB / 16 KB (programmable)
• Default	1024 bytes / 1024 bytes
• Number of process image partitions	Maximum 15
Consistent data	Maximum 244 bytes
Digital channels	Maximum 131072 / maximum 131072
• Of those are central	Maximum 131072 / maximum 131072
Analog channels	Maximum 8192 / maximum 8192
• Of those are central	Maximum 8192 / maximum 8192
Configuration	
Central racks/expansion units	Maximum 1/21
Multicomputing	Maximum 4 CPUs with UR1 or UR2 maximum 2 CPUs with CR3
Number of plug-in IMs (total)	Maximum 6
• IM 460	Maximum 6
• IM 463-2	Maximum 4

10.9 Specifications of the CPU 417-4 (6ES7417-4XT05-0AB0)

Number of DP masters	
• Integrated	2
• Via IF 964-DP	2
• Via IM 467	Maximum 4
• Via CP 443-5 Extended	Maximum 10
IM 467 cannot be used with the CP 443-5 Extended IM 467 cannot be used with the CP 443-1 EX4x in PN IO mode	
Number of PN IO controllers	
• Via CP 443-1 in PN IO mode	Maximum 4 in central rack, see manual for CP 443-1, no combined operation of CP 443-1 EX40 and CP 443-1 EX41/EX20/GX20
Number of plug-in S5 modules via adapter casing (in the central rack)	Maximum 6
Operable FMs and CPs	
• FM	Limited by the number of slots and the number of connections
• CP 440	Limited by the number of slots
• CP 441	Limited by the number of connections
• PROFIBUS and Ethernet CPs including CP 443-5 Extended and IM 467	Maximum 14 No more than 10 of which may be CPs or IMs as DP master, up to 4 PN controllers
Time	
Clock	Yes
• Buffered	Yes
• Resolution	1 ms
• Accuracy after POWER OFF	Maximum deviation per day 1.7 s
• Accuracy after POWER ON	Maximum deviation per day 8.6 s
Operating hours counter	16
• Number	0 to 15
• Value range	0 to 32767 hours 0 to $2^{31} - 1$ hours when SFC 101 is used
• Granularity	1 hour
• Retentive	Yes
Time synchronization	Yes
• In PLC, on MPI, DP and IF 964 DP	As master or slave
Time difference in the system with synchronization via MPI	Maximum 200 ms

S7 message functions	
Number of stations that can log on for message functions (e.g. WIN CC or SIMATIC OP)	Maximum 16 with ALARM_8 or ALARM_P (WinCC); up to 63 with ALARM_S or ALARM_D (OPs)
Symbol-related messages	Yes
<ul style="list-style-type: none"> Number of messages <ul style="list-style-type: none"> Total 100 ms interval 500 ms interval 1000 ms interval 	Maximum 1024 Maximum 128 Maximum 512 Maximum 1024
<ul style="list-style-type: none"> Number of auxiliary values per message <ul style="list-style-type: none"> With 100 ms interval With 500, 1000 ms interval 	Maximum 1 Maximum 10
Block-related messages	Yes
<ul style="list-style-type: none"> Simultaneously active ALARM_S/SQ blocks and ALARM_D/DQ blocks 	Maximum 1000
ALARM_8 blocks	Yes
<ul style="list-style-type: none"> Number of communication jobs for ALARM_8 blocks and blocks for S7 communication (programmable) 	Maximum 10000
<ul style="list-style-type: none"> Default 	1200
Process control messages	Yes
Number of archives that can log on simultaneously (SFB 37 AR_SEND)	64
Test and startup functions	
Status/modify variable	Yes, maximum 16 variable tables
<ul style="list-style-type: none"> Variable 	Inputs/outputs, bit memories, DB, distributed I/O, timers, counters
<ul style="list-style-type: none"> Number of variables 	Maximum 70
Force	Yes
<ul style="list-style-type: none"> Variable 	Inputs/outputs, bit memories, distributed I/O
<ul style="list-style-type: none"> Number of variables 	Maximum 512
Status block	Yes, maximum 2 blocks at the same time
Single-step	Yes
Number of breakpoints	4
Diagnostic buffer	Yes
<ul style="list-style-type: none"> Number of entries 	Maximum 3200 (programmable)
<ul style="list-style-type: none"> Default 	120
Cyclic interrupts	
Value range	500 µs to 60000 ms

10.9 Specifications of the CPU 417-4 (6ES7417-4XT05-0AB0)

Communication	
PG/OP communication	Yes
Number of connectable OPs	63
Number of connection resources for S7 connections via all interfaces and CPs	64, with one each of those reserved for programming device and OP
Global data communication	Yes
• Number of GD circuits	Maximum 16
• Number of GD packets Sender Receiver	Maximum 16 Maximum 32
• Size of GD packets Consistent of this	Maximum 54 bytes 1 variable
S7 basic communication	Yes
• MPI Mode	Via SFC X_SEND, X_RCV, X_GET and X_PUT
• DP Master Mode	Via SFC I_GET and I_PUT
• User data per job Consistent of this	Maximum 76 bytes 1 variable
S7 communication	Yes
• User data per job Consistent of this	Maximum 64 KB 1 variable (462 bytes)
S5-compatible communication	Via FC AG_SEND and AG_RECV, max. via 10 CP 443-1 or 443-5)
• User data per job Consistent of this	Maximum 8 KB 240 bytes
• Number of simultaneous AS-SEND/AS-RECV jobs per CPU, maximum	64/64
Standard communication (FMS)	Yes (via CP and loadable FB)
Open IE communication	ISO on TCP via CP 443-1 and downloadable FBs
• Maximum data length	1452 bytes
Interfaces	
1st interface	
Type of interface	Integrated
Features	RS 485 / PROFIBUS
Electrically isolated	Yes
Power supply to interface 24 V rated voltage (15 to 30 VDC)	Maximum 150 mA
Number of connection resources	MPI: 44 DP: 32 a diagnostic repeater in the line reduces the number of connection resources on the line by 1
Functionality	
MPI	Yes
PROFIBUS DP	DP master/DP slave

10.9 Specifications of the CPU 417-4 (6ES7417-4XT05-0AB0)

1st interface MPI mode	
Services	
PG/OP communication	Yes
Routing	Yes
Global data communication	Yes
S7 basic communication	Yes
S7 communication	Yes
Time synchronization	Yes
Transmission rates	Up to 12 Mbps
1st interface DP master mode	
Services	
PG/OP communication	Yes
Routing	Yes
S7 basic communication	Yes
S7 communication	Yes
Constant cycle	Yes
SYNC/FREEZE	Yes
Activate/deactivate DP slaves	Yes
Time synchronization	Yes
Direct data communication (internetwork traffic)	Yes
Transmission rates	Up to 12 Mbps
Number of DP slaves	Maximum 32
Address area	Maximum 2 KB inputs / 2 KB outputs
Number of slots per interface	Maximum 544
User data per DP slave	Maximum 244 bytes maximum 244 bytes I and maximum 244 bytes O, maximum 244 slots maximum 128 bytes per slot
Note:	
<ul style="list-style-type: none"> • The total sum of the input bytes across all slots may not exceed 244. • The total sum of the output bytes across all slots may not exceed 244. • The address range of the interface (maximum 2 KB inputs / 2 KB outputs) must not be exceeded in total across all 32 slaves. 	
1st interface DP slave mode	
You can only configure the CPU once as a DP slave even if the CPU has several interfaces.	
Service	
Status/force	Yes
Programming	Yes
Routing	Yes
Time synchronization	Yes
GSD file (http://support.automation.siemens.com/WW/view/en/113652)	
Transmission rate	Up to 12 Mbps
Transfer memory	244 bytes inputs / 244 bytes outputs
Virtual slots	Maximum 32
User data per address area	Maximum 32 bytes
Consistent of this	32 bytes

10.9 Specifications of the CPU 417-4 (6ES7417-4XT05-0AB0)

2nd interface	
Type of interface	Integrated
Features	RS 485 / PROFIBUS
Electrically isolated	Yes
Power supply to interface 24 V rated voltage (15 to 30 VDC)	Maximum 150 mA
Number of connection resources	32 a diagnostic repeater in the line reduces the number of connection resources on the line by 1
Functionality	
PROFIBUS DP	DP master/DP slave
2nd interface DP master mode	
Services	
PG/OP communication	Yes
Routing	Yes
S7 basic communication	Yes
S7 communication	Yes
Constant cycle	Yes
SYNC/FREEZE	Yes
Activate/deactivate DP slaves	Yes
Time synchronization	Yes
Direct data communication (internetwork traffic)	Yes
Transmission rates	Up to 12 Mbps
Number of DP slaves	Maximum 125
Number of slots per interface	Maximum 2173
Address area	Maximum 8 KB inputs / 8 KB outputs
User data per DP slave	Maximum 244 bytes maximum 244 bytes I and maximum 244 bytes O, maximum 244 slots maximum 128 bytes per slot
Note:	
<ul style="list-style-type: none"> • The total sum of the input bytes across all slots may not exceed 244. • The total sum of the output bytes across all slots may not exceed 244. • The address area of the interface (maximum 8 KB inputs / 8 KB outputs) may not be exceeded in sum across all 125 slaves. 	
2nd interface DP slave mode	
Specifications as for 1st interface	
3rd interface	
Type of interface	Plug-in interface module
Usable interface module	IF 964-DP
Technical features as for the 2nd interface	
4th interface	
Type of interface	Plug-in interface module
Usable interface module	IF 964-DP
Technical features as for the 2nd interface	

Programming	
Programming language	LAD, FBD, STL, SCL, S7 GRAPH, S7 HiGraph
Instruction set	See <i>Instruction List</i>
Nesting levels	7
System functions (SFC)	See <i>Instruction List</i>
Number of simultaneously active SFCs per segment	
• SFC 11 "DPSYC_FR"	2
• SFC 12 "D_ACT_DP"	8
• SFC 59 "RD_REC"	8
• SFC 58 "WR_REC"	8
• SFC 55 "WR_PARM"	8
• SFC 57 "PARM_MOD"	1
• SFC 56 "WR_DPARM"	2
• SFC 13 "DPNRM_DG"	8
• SFC 51 "RDSYSST"	1 ... 8
• SFC 103 "DP_TOPOL"	1
System function blocks (SFB)	See <i>Instruction List</i>
Number of simultaneously active SFBs	
• SFB 52 "RDREC"	8
• SFB 53 "WRREC"	8
User program protection	Password protection
Access to consistent data in the process image	Yes
CiR synchronization time	
Base load	60 ms
Time per I/O byte	7 µs
Isochronous mode	
User data per isochronous slave	Maximum 244 bytes
Maximum number of bytes and slaves in a process image partition	The following must apply: number of bytes/100 + number of slaves < 44
Constant bus cycle time	Yes
Shortest clock pulse	1 ms 0.5 ms without use of SFC 126, 127
Longest clock pulse	32 ms
See <i>Isochronous Mode</i> manual	
Dimensions	
Mounting dimensions WxHxD (mm)	50x290x219
Slots required	2
Weight	Approx. 0.92 kg

10.9 Specifications of the CPU 417-4 (6ES7417-4XT05-0AB0)

Voltages, currents	
Current consumption from the S7-400 bus (5 VDC)	Typically 1.5 A Maximum 1.8 A
Current consumption from S7-400 bus (24 VDC) The CPU does not consume any current at 24 V, it only makes this voltage available at the MPI/DP interface.	Total current consumption of the components connected to the MPI/DP interfaces, with a maximum of 150 mA per interface
Backup current	Typically 225 µA (up to 40° C) Maximum 750 µA
Maximum backup time	See <i>Module Specifications</i> reference manual, Section 3.3.
Supply of external backup voltage to CPU	5 to 15 VDC
Power loss	Typ. 7.5 W

10.10 Technical specifications of the memory cards

Data

Name	Order number	Current consumption at 5 V	Backup currents
MC 952 / 64 Kbytes / RAM	6ES7952-0AF00-0AA0	typ. 20 mA max. 50 mA	typ. 0.5 µA max. 20 µA
MC 952 / 256 Kbytes / RAM	6ES7952-1AH00-0AA0	typ. 35 mA max. 80 mA	typ. 1 µA max. 40 µA
MC 952 / 1 MB / RAM	6ES7952-1AK00-0AA0	typ. 40 mA max. 90 mA	typ. 3 µA max. 50 µA
MC 952 / 2 MB / RAM	6ES7952-1AL00-0AA0	typ. 45 mA max. 100 mA	typ. 5 µA max. 60 µA
MC 952 / 4 MB / RAM	6ES7952-1AM00-0AA0	typ. 45 mA max. 100 mA	typ. 5 µA max. 60 µA
MC 952 / 8 MB / RAM	6ES7952-1AP00-0AA0	typ. 45 mA max. 100 mA	typ. 5 µA max. 60 µA
MC 952 / 16 MB / RAM	6ES7952-1AS00-0AA0	typ. 100 mA max. 150 mA	typ. 50 µA max. 125 µA
MC 952 / 64 MB / RAM	6ES7952-1AY00-0AA0	typ. 100 mA max. 150 mA	typ. 100 µA max. 500 µA
MC 952 / 64 KB / 5V FLASH	6ES7952-0KF00-0AA0	typ. 15 mA max. 35 mA	–
MC 952 / 256 KB / 5V FLASH	6ES7952-0KH00-0AA0	typ. 20 mA max. 45 mA	–
MC 952 / 1 Mbytes / 5V Flash	6ES7952-1KK00-0AA0	typ. 40 mA max. 90 mA	–
MC 952 / 2 Mbytes / 5V Flash	6ES7952-1KL00-0AA0	typ. 50 mA max. 100 mA	–
MC 952 / 4 Mbytes / 5V Flash	6ES7952-1KM00-0AA0	typ. 40 mA max. 90 mA	–
MC 952 / 8 Mbytes / 5V Flash	6ES7952-1KP00-0AA0	typ. 50 mA max. 100 mA	–
MC 952 / 16 Mbytes / 5V Flash	6ES7952-1KS00-0AA0	typ. 55 mA max. 110 mA	–
MC 952 / 32 Mbytes / 5V Flash	6ES7952-1KT00-0AA0	typ. 55 mA max. 110 mA	–
MC 952 / 64 Mbytes / 5V Flash	6ES7952-1KY00-0AA0	typ. 55 mA max. 110 mA	–
Dimensions WxHxD (in mm)	7.5 x 57 x 87		
Weight	Max. 35 g		
EMC protection	Provided by construction		

See also

GSD (<http://support.automation.siemens.com/WW/view/en/113652>)

IF 964-DP interface module

11.1 Using the IF 964-DP interface module

Order numbers

You can use the IF 964-DP interface module with order number 6ES7964-2AA04-0AB0 in the CPUs of the S7-400 as of firmware version 4.0.

The interface module identifier is on the front panel and can therefore be identified when it is installed.

Features

The IF 964-DP is used to connect distributed I/Os over "PROFIBUS-DP". The module has a floating RS-485 interface. The transmission rate is 12 Mbps maximum.

The permitted cable length depends on the transmission rate and the number of nodes. On a point-to-point link at a transmission rate of 12 Mbps, a cable length of 100 m is possible and at 9.6 Kbps, a length of 1200 m can be achieved.

Up to 125 slave stations/slaves can be connected to the interface module, depending on the CPU used.

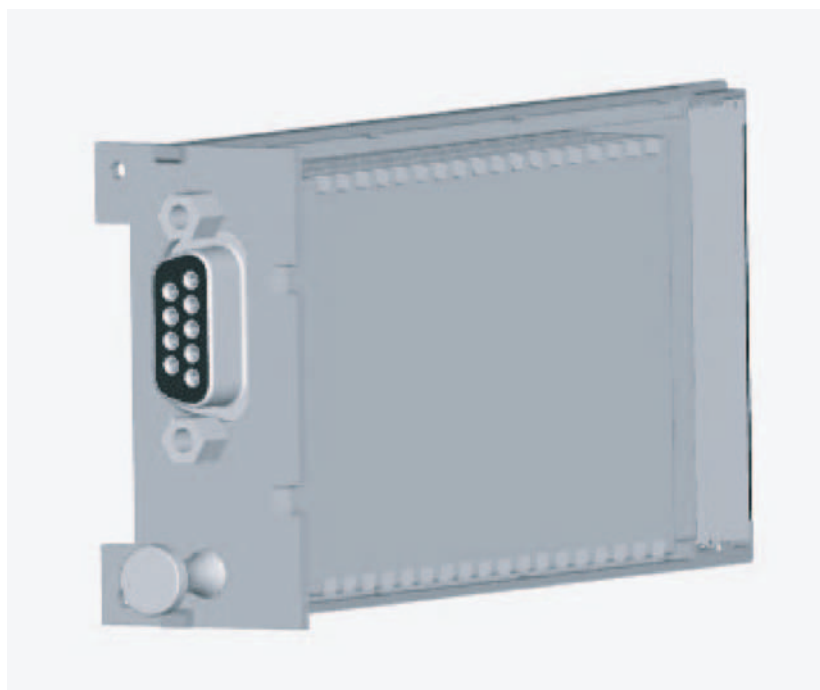

Figure 11-1 IF 964-DP interface module

Further Information

You will find information on "PROFIBUS-DP" in the following brochures and manuals:

- Manuals for the DP masters, for example the *S7-300 programmable controller* or *S7-400 automation system* for the PROFIBUS-DP interface
- Manuals for the DP slaves, for example, *ET 200M distributed I/O station* or *ET 200C distributed I/O station*
- Manuals for STEP 7

11.2 Technical specifications

Technical specifications

The IF 964-DP interface module obtains its power from the CPU. The following technical specifications include the necessary current consumption to allow dimensioning of the power supply unit.

Dimensions and weight	
Dimensions W x H x D (mm)	26 x 54 x 130
Weight	0.065 kg
Performance features	
Transmission rate	9.6 Kbps to 12 Mbps
Length of cable • at 9.6 Kbps • at 12 Mbps	maximum 1200 m maximum 100 m
Number of stations	≤125 (depending on the CPU used)
Physical interface characteristics	RS-485
Isolation	Yes
Voltages, Currents	
Power supply	supplied by the S7-400
Current consumption from the S7-400 bus The CPU does not consume any current at 24 V, it only makes this voltage available at the MPI/DP interface.	Total current consumption of the components connected to the DP interface, however maximum of 150 mA
Possible load of the floating 5 V (P5 _{ext})	Maximum 90 mA
Possible load of the 24 V	Maximum 150 mA
Module identifier	C _H
Power loss	1 W

Index

A

- Additional support, 13
- Address area
 - CPU 41x-2, 136

B

- Backup, 187
- Basic knowledge
 - Required, 11
- Block stack, 186
- Blocks
 - Compatibility, 174
- Bus topology
 - Detection, 141
 - Determining, 151
- BUSF, 141, 151

C

- Calculation
 - Response time, 199
- CBA components, 170
- CiR, 51
 - Hardware requirements, 52
 - Software requirements, 53
- Cold start, 34
 - Operating sequence, 35
- Communication
 - CPU services, 67
 - CPU to CPU, 41
 - Faults, 90
 - Global data communication, 73
 - Open IE communication, 83
 - PG/OP communication, 41
 - S7 basic communication, 70
 - S7 communication, 71
- Communication load, 196
- Communication Load, 91
 - Definition, 90
- Communication performance, 90
- Communication services
 - Overview, 67
 - S7 communication, 71
- Compatibility

- DPV1 and EN 50170, 138
- Configuration frame, 146
- Connection resources, 67
- Connectors
 - DP interface, 43
 - MPI interface, 42
- Consistent data, 179
 - Access to the work memory, 180
 - Communication blocks, 180
 - Communication functions, 180
 - DP standard slave, 181
 - Process image, 182
 - SFC 15 DPWR_DAT, 181
 - SFC 81 UBLKMOV, 179
 - SFC14 DPRD_DAT, 181
- Consistent user data, 139
- Constant bus cycle time, 138
- Control and display elements of CPU 412-1, 15
- Control and display elements of CPU 417-4, 19
- Control and display elements of CPU 41x-2, 16
- Control and display elements of CPU 41x-3, 17
- Control and display elements of CPU 41x-3PN/DP, 18
- Courses, 13
- CPU
 - Error displays and special features, 27
 - Parameter fields, 45
 - Parameters, 45
 - Resetting to the factory settings, 55
- CPU 412-1
 - Control and display elements, 15
- CPU 417-4
 - Control and display elements, 19
- CPU 41x
 - Bus interruption, 144
 - DP master, 137
 - DP master diagnostics with STEP 7, 142
 - Operating mode changes, 144
 - Transfer memory, 147
- CPU 41x-2
 - Bus interruption, 154, 163
 - Control and display elements, 16
 - Diagnostic addresses for PROFIBUS, 144
 - Diagnostics addresses for PROFIBUS, 153
 - DP address areas, 136
 - DP master: diagnostics with LEDs, 141
 - DP slave, 146
 - DP slave diagnostics with STEP 7, 151
 - DP slave: diagnostics with LEDs, 151

- Operating mode changes, 154, 163
- CPU 41x-3
 - Control and display elements, 17
- CPU 41x-3 PN/DP
 - Error displays and special features, 28
- CPU 41x-3PN/DP
 - Control and display elements, 18
- CPU to CPU communication, 41
- Cycle time, 189
 - Calculation example, 205, 206
 - Communication load, 196
 - increasing, 191
 - Maximum cycle time, 194
 - Minimum Cycle Time, 195
 - Parts, 190
- Cycle times, 194

D

- Data consistency, 197
- Device-Related Diagnostics
 - CPU 41x-2 as DP slave, 159
- Diagnostic addresses
 - CPU 41x-2, 144
- Diagnostic interrupt
 - CPU 41x-2 as DP slave, 160
- Diagnostic interrupt response time, 211
- Diagnostics
 - analyzing in the user program, 143
 - Device-related:CPU 41x-2 as DP slave, 159
 - Direct data exchange, 163
 - identifier-related, 158
 - Reading, 142, 152
- Diagnostics addresses
 - CPU 41x-2, 153
- Direct data exchange
 - Diagnostics, 163
- Direct Data Exchange, 162
- Documentation package, 12
- DP cycle times, 200
- DP diagnostics addresses
 - Address area, 136
- DP interface, 43
 - Connectors, 43
- DP master
 - AG-S5-95, 148
 - CPU 41x, 137
 - Diagnostics with LEDs, 141
 - Diagnostics with STEP 7, 142
 - PROFIBUS address, 140
 - S5, 148
- DP master system

- Startup, 140
- DP slave
 - CPU 41x-2, 146
 - Diagnostics with LEDs, 151
 - Diagnostics with STEP 7, 151
- DP slave diagnostics data
 - Reading, 152
 - Structure, 155
- DP standard slave
 - Consistent data, 181
- DPV1, 137
- DPV1 components, 137

E

- EN 50170, 137
- Equidistant, 165
- Equidistant PROFIBUS, 165
- Error displays, 28
 - all CPUs, 27
 - CPU 41x-3 PN/DP, 28
- Error messages, 23
- ETHERNET interface, 44, 65
- External backup voltage
 - Power input, 22

F

- Factory settings, 55
- Faults
 - Communication, 90
- FEPROM card, 38
- Firewall, 96
- Firmware
 - Updating, 57
- FLASH card, 38
 - Use, 38
- Flexible memory capacity, 187
- Freeze, 139

G

- Gateway, 75
- GD communication, 73
- Global data communication, 73

H

- Hardware interrupt
 - CPU 41x-2 as DP slave, 160
- Hardware interrupt processing, 210

Hardware interrupt response time, 209
 of signal modules, 210
 of the CPUs, 209, 210
 Hot restart, 34
 Operating sequence, 35
 Hotline, 13

I

I/O direct accesses, 203
 ID-related diagnostics, 158
 IE communication, 84
 Data blocks, 84
 IF 964-DP
 Features, 301
 Manuals, 302
 Technical specifications, 303
 iMap, 170
 Interface
 MPI/DP, 21
 PROFIBUS DP, 21
 PROFINET, 21
 Interface modules
 Slot, 21
 interfaces
 MPI interface, 61
 MPI interface:capable devices, 62
 MPI Interface:MPI interface as a PROFIBUS DP
 interface, 61
 MPI interface:time synchronization, 61
 Interfaces
 PROFIBUS DP Interface, 63
 PROFINET interface, 44, 65
 Interrupt changes
 during operation, 53
 Interrupts
 CPU 41x-2 as DP slave, 160
 IP address
 Assigning, 44, 65
 Memory reset, 33
 Isochrone, 165
 Isochronous mode, 138
 Isochronous PROFIBUS, 165

L

LED IFM1F, 28
 LED IFM2F, 28
 LED MAINT, 29
 LEDs, 20

M

Manual
 Purpose, 11
 Manual package, 12
 Master PROFIBUS address, 157
 Maximum cycle time, 194
 Memory areas
 Basis for the calculation, 187
 Memory areas, 185
 Memory card
 Capacity, 39
 Design, 36
 Function, 36
 Serial number, 37
 Types, 38
 Memory Card
 Changing, 40
 Memory Cards
 Slot, 21
 Memory reset
 IP address, 33
 MPI parameters, 33
 Operating sequence, 32
 Process, 32
 Upon request, 32
 Memory size, 187
 Minimum cycle time, 195
 Mode selector switch
 Positions, 30
 Mode switch, 20
 Monitoring functions, 23
 MPI interface, 41, 61
 Connectors, 42
 MPI parameters
 Memory reset, 33
 MPI/DP interface, 21
 Multicomputing, 47
 Accessibility of the CPUs., 49
 Address assignment, 49
 Behavior during operation, 49
 Behavior during start up, 49
 Downloading the configuration, 49
 Example, 48
 Interrupt assignment, 49
 Interrupt processing, 50
 Number of I/Os, 50
 Rack, 47
 Slot rules, 49
 Uses, 48
 Multicomputing interrupt, 50

N

- Network functions
 - S7 communication, 71

O

- OB 83, 176
- OB 86, 176
- Operating range, 90
- Operating system
 - Execution time, 193
- Order number
 - 6ES7 412-1XJ05-0AB0, 217
 - 6ES7 412-2XJ05-0AB0, 225
 - 6ES7 414-2XK05-0AB0, 233
 - 6ES7 414-3EM05-0AB0, 250
 - 6ES7 414-3XM05-0AB0, 241
 - 6ES7 416-2FN05-0AB0, 262
 - 6ES7 416-2XN05-0AB0, 262
 - 6ES7 416-3ER05-0AB0, 279
 - 6ES7 416-3XR05-0AB0, 270
 - 6ES7 417-4XT05-0AB0, 291
- Order numbers
 - Memory card, 300
- Organization blocks, 176

P

- Parameter fields, 45
- Parameterization frame, 146
- Parameters, 45
- PG/OP ->CPU Communication, 41
- Power input
 - External backup voltage, 22
- Process image, 189
- Process image update
 - Processing time, 191
 - scan time, 192
- PROFIBUS
 - Equidistant, 165
 - Isochrone, 165
- PROFIBUS address, 150
- PROFIBUS address of the DP master, 140
- PROFIBUS DP
 - Organization blocks, 176
 - System and standard functions, 174
 - System status list, 177
- PROFIBUS DP Interface
 - Connectable devices, 63
 - Time synchronization, 63
- PROFIBUS DP Interface, 63

- PROFIBUS DP Interface, 21
- PROFINET, 44, 65, 169
 - Interface, 44, 65
- PROFINET CBA, 171
- PROFINET interface, 21
 - Properties, 65
- PROFINET IO, 171
 - Advanced functions, 172
 - Organizational blocks, 176
 - System and Standard Functions, 174
 - System status list, 177
- Programming
 - via PROFIBUS, 146

R

- RAM card, 38
 - Use, 38
- Reboot, 34
 - Operating sequence, 35
- Reproducibility, 212
- Reset to factory setting, 55
- Response time, 167, 199
 - Calculation, 199
 - Calculation of the, 202, 203
 - Diagnostic interrupt, 211
 - Longest, 202
 - Parts, 199
 - Process interrupt, 209
 - Reducing, 203
 - Shortest, 201
- RJ45 connector, 44
- Routing, 74

S

- S5 DP Master, 148
- S7 basic communication, 70
- S7 communication, 71
 - Description, 71
- S7 connections
 - End point, 87
 - of CPUs 41x, 68
 - Time sequence for allocation, 89
 - Transition point, 87
- S7 diagnostics, 152
- S7 routing
 - Access to stations on other subnets, 74
 - Application example, 77
 - Gateway, 75
 - Requirements, 74
- S7-400 CPUs

- Memory types, 186
- scan time
 - Operating system, 193
 - Process image update, 192
 - Process Image Updating, 191
- Scope
 - Of the manual, 12
- Security
 - of the Web server, 96
- Security class, 31
 - Setting, 31
- Serial number, 37
- Service data
 - Procedure, 59
 - Use case, 59
- Services
 - S7 communication, 71
- SFB 52 "RDREC", 174
- SFB 54 "RALRM", 174
- SFB 81 "RD_DPAR", 174, 175
- SFB53 "WRREC", 174
- SFBs
 - S7 communication, 72
- SFC 109 PROTECT, 31
- SFC 11 "DPSYC_FR", 175
- SFC 12 "D_ACT_DP", 174
- SFC 49 "LGC_GADR", 175
- SFC 5 "GADR_LGC", 174
- SFC 54 "RD_DPARM", 175
- SFC 58 "WR_REC", 174
- SFC 59 "RD_REC", 174
- SFC 7 "DP_PRAL", 175
- SFC 70 "GEO_LOG", 174
- SFC 71 "LOG_GEO", 175
- SFC 72 "I_GET", 175
- SFC 73 "I_PUT", 175
- SFC 74 "I_ABORT", 175
- SFC 81 UBLKMOV, 179
- SFC103 "DP_TOPOL", 175
- SFC13 "DPNRM_DG", 174
- SFC55 "WR_PARM", 175
- SFC56 "WR_DPARM", 175
- SFC57 "PARM_MOD", 175
- SFCs
 - Global Data Communication, 73
 - S7 basic communication, 70
- SIMATIC iMap, 170
- Simple Network Management Protocol, 82
- Slot
 - Interface modules, 21
 - Memory Cards, 21
- SNMP, 82
- SSL

- W#16#0696, 178
- W#16#0A91, 177
- W#16#0C91, 177
- W#16#0C96, 178
- W#16#0x94, 178
- W#16#4C91, 177
- W#16#xy92, 178
- Startup of the DP master system, 140
- Station status 1 to 3, 156
- STATUS / CONTROL
 - via PROFIBUS, 146
- Status LEDs
 - all CPUs, 26
- Support
 - Additional, 13
- Sync, 139
- System and standard functions, 174
- System and Standard Functions, 175
- System status list
 - compatibility, 177

T

- Technical specifications
 - CPU 412-1, 217
 - CPU 412-2, 225
 - CPU 414-2, 233
 - CPU 414-3, 241
 - CPU 416-2, 262
 - CPU 416-3, 270
 - CPU 416-3 PN/DP, 279
 - CPU 416F-2, 262
 - CPU 417-4, 291
 - IF 964-DP, 303
 - Memory card, 300
- Technical Support, 13
- Time synchronization
 - via MPI, 41
 - via PROFIBUS, 43
 - via PROFIBUS DP, 63
 - via PROFINET, 44
- Time-Sharing Model, 189
- Toggle switch, 31
- Training Centers, 13
- Transfer memory
 - Address areas, 147
 - CPU 41x, 147
 - for data transfer, 147
 - Rules, 148

U

- Updating online
 - the firmware, 57
- Updating the firmware, 57

W

- Warm restart, 34
- Web Access on the CPU, 95
- Web server
 - activate, 95, 97, 98
 - Automatic update, 97, 98
 - Diagnostic buffer, 107
 - Identification, 106
 - Intro, 104
 - Language setting, 100
 - Messages, 114
 - Order number, 106
 - PROFINET, 116
 - Refresh status of printing, 102
 - Screen display refresh status, 102
 - Security, 96
 - Start page, 105
 - Variable status, 131
 - Variable tables, 133
 - Version, 106
- Web server, 94

