

Mounting of terminal covers
Montage des capots
Montaje de los Cubrebornes

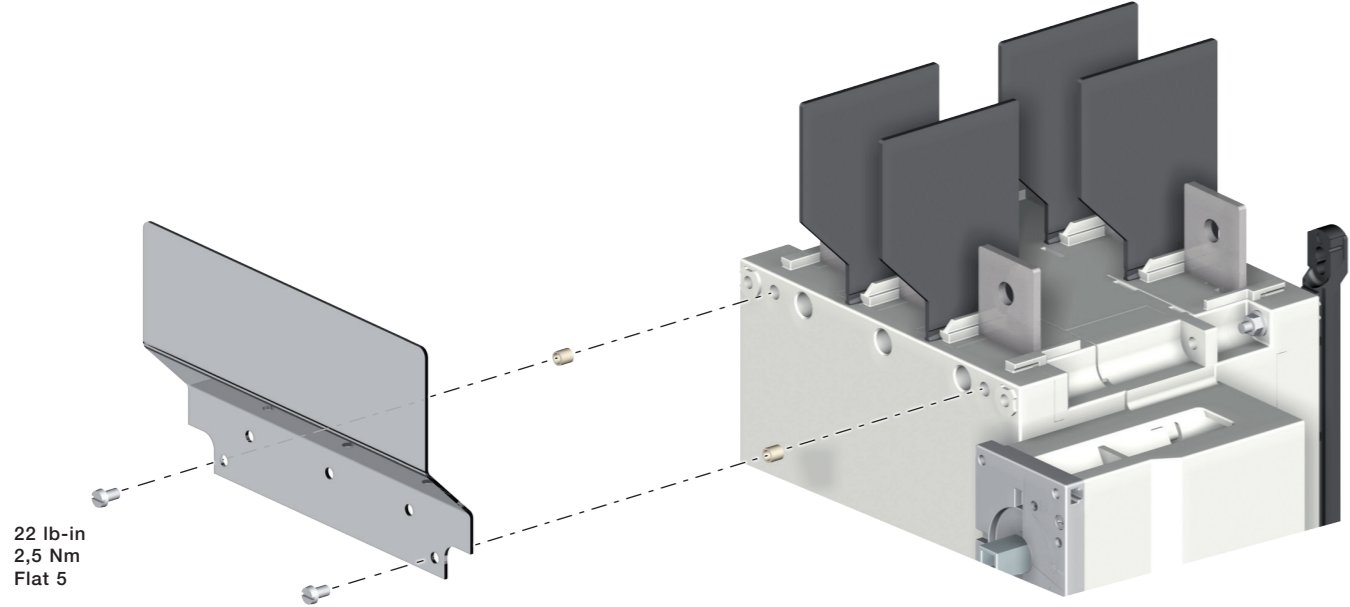

	Ref. TOP or BOTTOM Ref. AMONT ou AVAL Referencia SUPERIOR o INFERIOR
41502026 / 41502042 41503026 / 41503042	41583041
41504026 / 41504042	41584041



Mounting of auxiliary contacts
Montage des contacts auxiliaires
Montaje de los contactos auxiliares



41590021 → 125 - 250 V a.c. 60 Hz
 General Use 10A
 1/2 HP
 I min. 100 mA

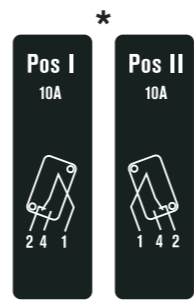

41590022 → 125 V a.c. 60 Hz
 General Use 1A

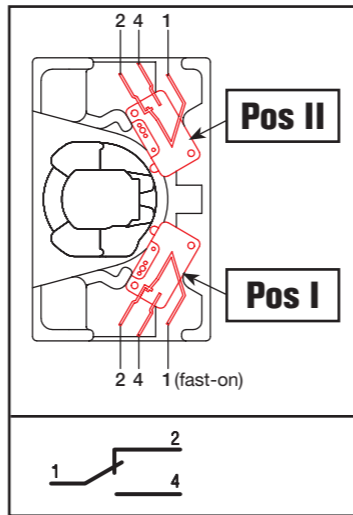
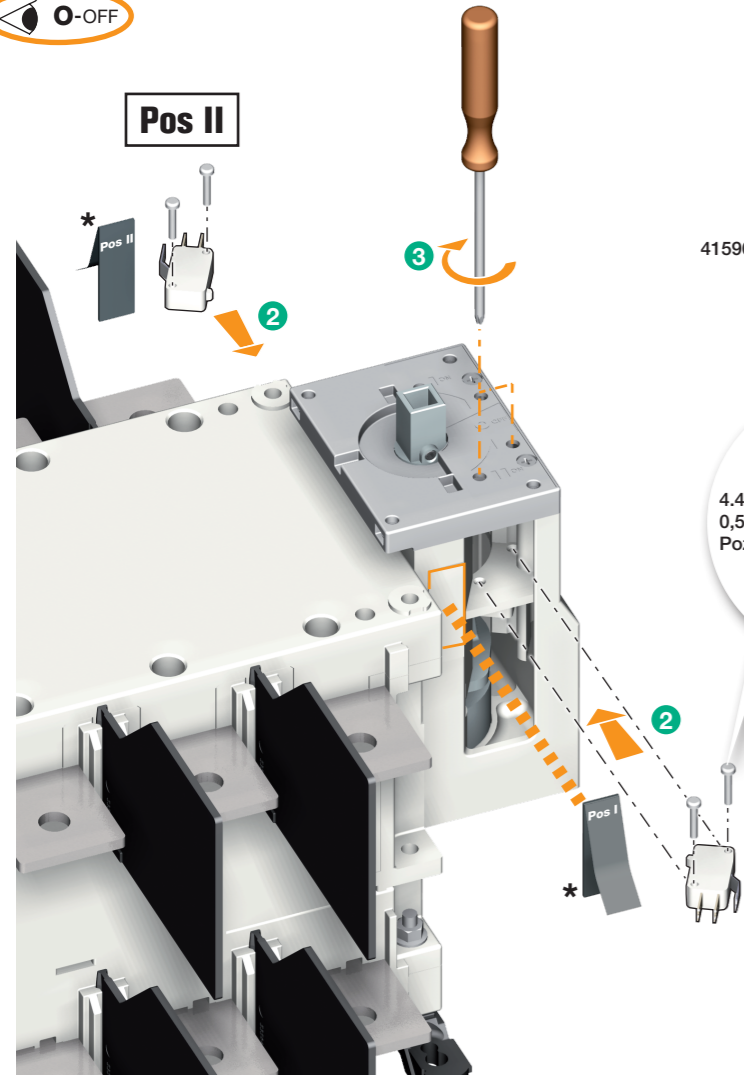
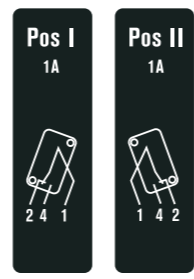

SIRCOVER UL 1008 260A - 400A

MANUAL TRANSFER SWITCH

⚠ DANGER / DANGER / PELIGRO

HAZARDOUS VOLTAGE

- This equipment must be installed and serviced only by qualified electrical personnel.
- Turn off all power supplying this equipment before working on or inside equipment.
- Always use a properly rated voltage sensing device to confirm power is off.
- Replace all devices, doors, and covers before turning on power to this equipment.
- Maintain electrical clearances between cable and live parts.

Failure to follow these instructions will result in death or serious injury.

TENSION DANGEREUSE

- L'installation et l'entretien de cet appareil ne doivent être effectués que par du personnel qualifié.
- Coupez l'alimentation de cet appareil avant d'y travailler.
- Utilisez toujours un dispositif de détection de tension à valeur nominale approprié pour confirmer que toute alimentation est coupée.
- Remplacez tous les dispositifs, les portes et les couvercles avant de mettre cet appareil sous tension.
- Maintenez les distances d'isolement électrique entre le câble et les pièces sous tension.

Si ces précautions ne sont pas respectées, cela entraînera la mort ou des blessures graves

TENSION PELIGROSA

- Solamente el personal de mantenimiento eléctrico especializado deberá instalar y prestar servicios de mantenimiento a este equipo.
- Desenergice el equipo antes de realizar cualquier trabajo en él.
- Siempre utilice un dispositivo detector de tensión adecuado para confirmar la desenergización del equipo.
- Vuelva a colocar todos los dispositivos, las puertas y las cubiertas antes de energizar este equipo.
- Mantenga un espacio adecuado para la instalación eléctrica entre el cable y las piezas energizadas.

El incumplimiento de estas precauciones podrá causar la muerte o lesiones serias.

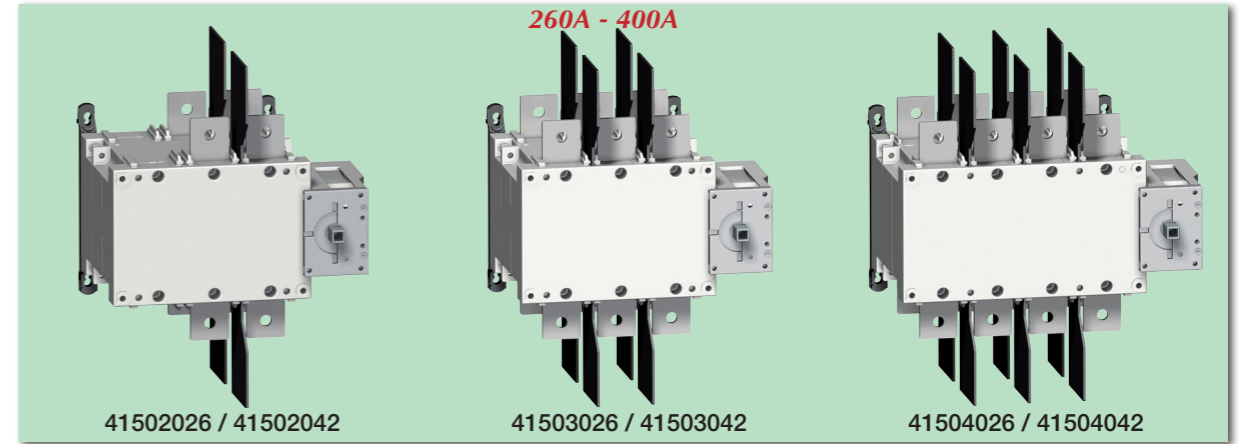

Switch and accessories
L'interrupteur et ses accessoires
El interruptor y sus accesorios

41583041 (2/3P)
 41584041 (4P)

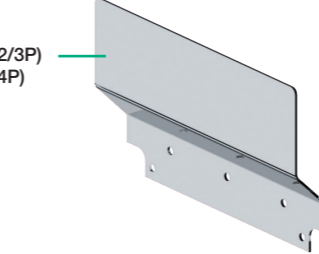

143D3113 / 143D3813
 143E3113 / 143E3813
 143F3113 / 143F3813
 143G3113 / 143G3813

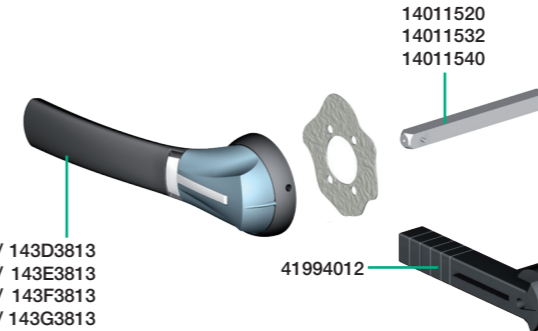

41583041 (2/3P)
 41584041 (4P)

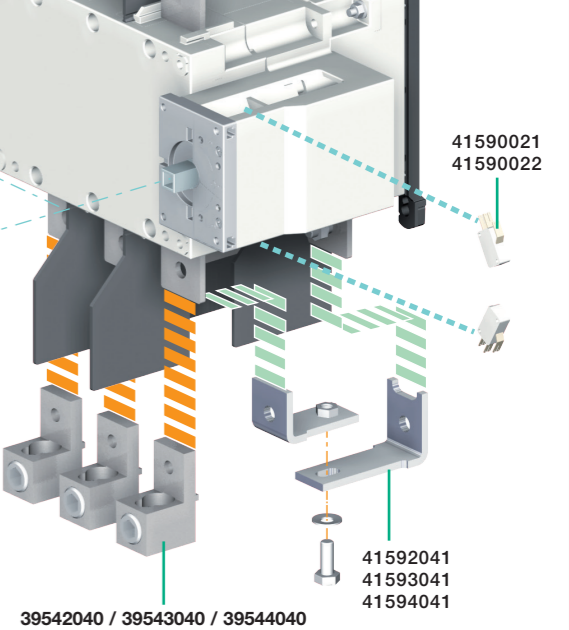
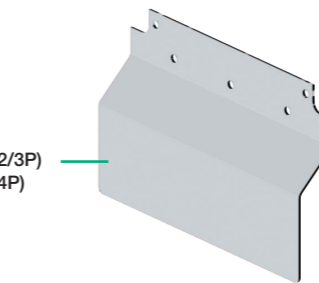

RECTO-VERSO / S blanc offset 80g/m² / QUADRI / F 297x420 / P 1 PLI ROULE - 1 PLI CROISE

- 1 41502026 / 41502042
41503026 / 41503042
- 2 41504026 / 41504042

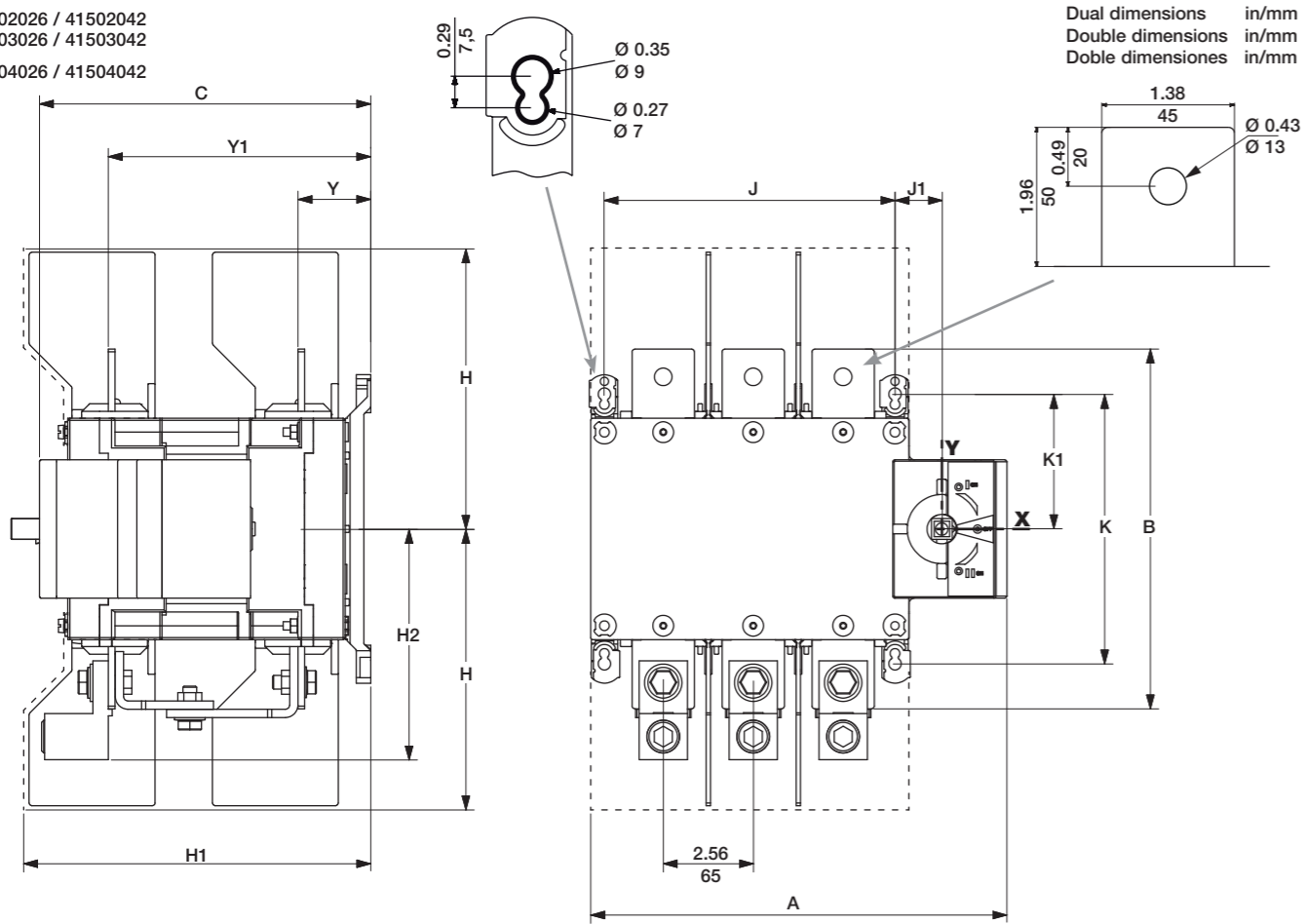

Dual dimensions in/mm
Double dimensions in/mm
Doble dimensiones in/mm

	A		B		C		H		H1		H2		J		J1		K		K1		Y		Y1	
	in	mm	in	mm	in	mm	in	mm	in	mm	in	mm	in	mm	in	mm	in	mm	in	mm	in	mm	in	mm
1 2/3P	11.85	301	10.23	260	9.41	239	8	203	6.51	165,5	6.53	166	8.26	210	1.37	35	7.67	195	3.84	97,5	2.04	52	7.48	190
2 4P	14.21	361	10.23	260	9.41	239	8	203	6.51	165,5	6.53	166	10.63	270	1.37	35	7.67	195	3.84	97,5	2.04	52	7.48	190

Minimum enclosure dimensions
Dimensions minimum des coffrets
Dimensiones minimas de las cajas

- 1 41502026 / 41502042
41503026 / 41503042
- 2 41504026 / 41504042

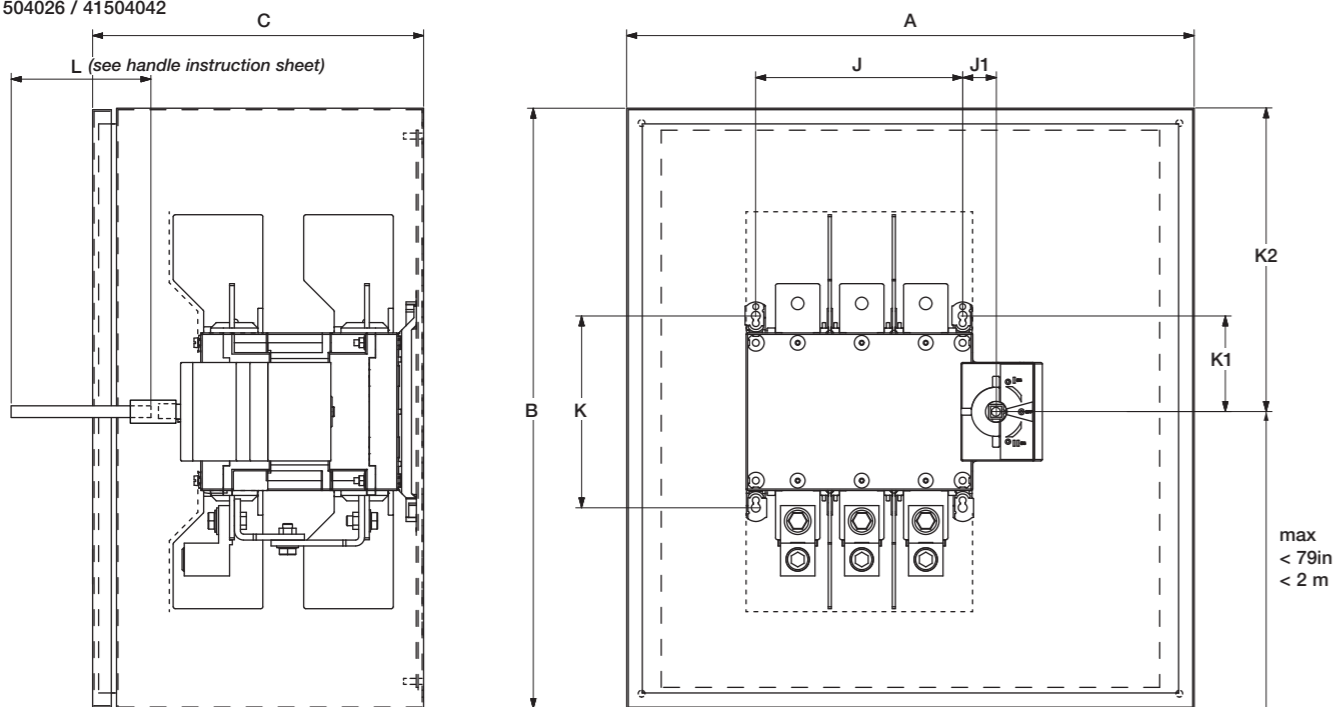

	A		B		C		J		J1		K		K1		K2	
	in	mm	in	mm	in	mm	in	mm	in	mm	in	mm	in	mm	in	mm
1 2/3P	24	610	30	762	12	305	8.26	210	1.37	35	7.67	195	3.84	97,5	15	381
2 4P	24	610	30	762	12	305	10.63	270	1.37	35	7.67	195	3.84	97,5	15	381

Connection
Raccordement
Conexión

- Lugs**
Bornes à cage
Bornes
- USED FOR
UTILISE POUR
UTILIZADO PARA
- 39542040 x3 → 41502026 / 41502042
 - 39543040 x3 → 41503026 / 41503042
 - 39544040 x3 → 41504026 / 41504042

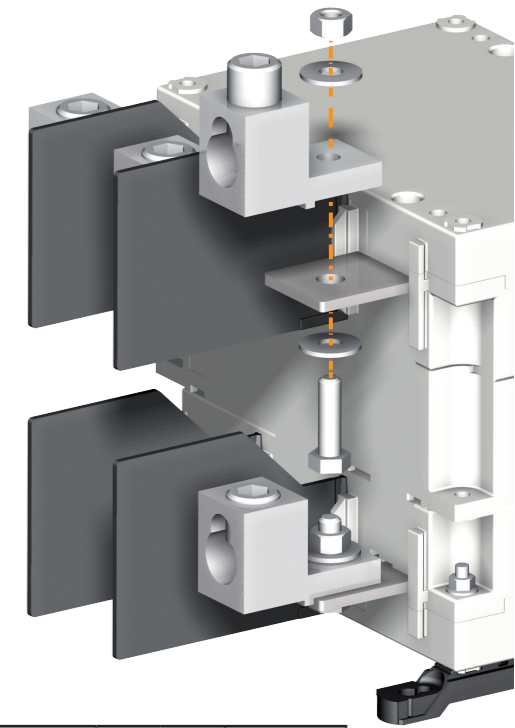

When ordering ensure to order QTY 3 or each lug reference
(2 x for source 1 and source 2 incoming power cables + 1x for outgoing cables)

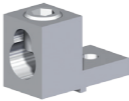
Ref. lugs Ref. bornes à cage Ref. bornes	Designation Désignation Designación	Quantity per reference. Quantité par ref. Cantidad por referencia	Size / Section Sección (AWG)		Openings per lug. Nombre de points de connexion. Numero de puntos de conexión.	Torque Couple Par de apriete		Size
			min.	max.		lb-in	Nm	
39542040 39543040 39544040	 CMC LA630-R	2 3 4	# 4 1/0	600 Kcmil 250 Kcmil	1 2	310 35	17	

- Bridging bars**
Barres de pontage
pletina de puenteado
- USED FOR
UTILISE POUR
UTILIZADO PARA
- 41592041 → 41502026 / 41502042
 - 41593041 → 41503026 / 41503042
 - 41594041 → 41504026 / 41504042

