

# INSTALLATION AND WIRING

---



## CHAPTER

# 2

### CONTENTS OF THIS CHAPTER

<i>Ambient Conditions</i> . . . . .	.2-2
<i>Storage Conditions</i> . . . . .	.2-2
<i>Installation</i> . . . . .	.2-3
<i>Minimum Clearances and Air Flow</i> . . . . .	2-3
<i>GS1 AC Drive Dimensions</i> . . . . .	.2-4
<i>GS1 Circuit Connections</i> . . . . .	.2-5
<i>Danger!</i> . . . . .	.2-5
<i>Wiring Notes: PLEASE READ PRIOR TO INSTALLATION</i> . . . . .	2-5
<i>Motor Operation Precautions</i> . . . . .	2-6
<i>Short Circuit Withstand</i> . . . . .	2-6
<i>Applicable Codes</i> . . . . .	2-6
<i>Circuit Protection Devices</i> . . . . .	.2-6
<i>Maximum Recommended Circuit Protection Devices</i> . . . . .	2-6
<i>Main Circuit Wiring</i> . . . . .	.2-7
<i>Input Power Connections</i> . . . . .	2-7
<i>Output Power Connections</i> . . . . .	2-8
<i>Control Terminal Wiring</i> . . . . .	.2-8
<i>Basic Wiring Diagram</i> . . . . .	.2-9
<i>External Wiring and Accessories</i> . . . . .	.2-10

## Ambient Conditions

Ambient environmental conditions for use:

Ambient Conditions	
<b>Ambient Temperature</b>	-10° to 40°C (14°F to 104°F) w/o derating
<b>Storage Temperature</b>	-20° to 60° C (-4°F to 140°F) during short-term transportation period)
<b>Relative Humidity</b>	0 to 90% RH (non-condensing)
<b>Atmosphere Pressure</b>	86 kPA to 106 kPA
<b>Vibration</b>	9.8 m/s <sup>2</sup> (1G) @ less than 10 Hz; 5.88 m/s <sup>2</sup> (0.6G) @ 10 to 50 Hz
<b>Installation Location</b>	Altitude 1000m or lower above sea level, keep from corrosive gas, liquid and dust
<b>Enclosure Rating</b>	Protected chassis, IP20

## Storage Conditions

GS1 AC drives should be kept in their shipping carton or crate until they are installed. In order to retain their warranty coverage, they should be stored as described below if they are not to be installed and used within three months.

- Store in a clean and dry location free from direct sunlight and corrosive fumes.
- For storage of longer than 3 months, store within an ambient temperature range of -20°C to 30°C (-4°F to 86°F).
- For storage of 3 months or less, store within an ambient temperature range of -20°C to 60°C (-4°F to 140°F).
- Store within a relative humidity range of 0% to 90% and non-condensing environment.
- Store within an air pressure range of 86 kPA to 106 kPA.
- DO NOT store in an area with rapid changes in temperature. (It may cause condensation and frost.)
- DO NOT place directly on the ground.



**NOTE:** If the drive is stored or is otherwise unused for more than a year, the drive's internal DC link capacitors should be recharged before use. Otherwise, the capacitors may be damaged when the drive starts to operate. We recommend recharging the capacitors of any unused drive at least once per year. (Refer to Chapter 6, "Maintenance and Troubleshooting" for information about recharging DC link capacitors.)

## Installation

Install the AC drive in an enclosure that is specifically designed to house electrical and electronic control equipment. Provide proper spacing within the enclosure to allow the dissipation of heat produced by the drive and any other included electrical and electronic equipment. Ventilation or air conditioning may also be required, depending upon the application.

Improper installation of the AC drive will greatly reduce its life. Be sure to observe the following precautions when selecting a mounting location:

- Do not mount the AC drive near heat-radiating elements or in direct sunlight.
- Do not install the AC drive in a place subjected to high temperature, high humidity, excessive vibration, corrosive gases or liquids, or airborne dust or metallic particles.
- Mount the AC drive vertically and do not restrict the air flow to the heat sink fins.



**WARNING:** FAILURE TO OBSERVE THESE PRECAUTIONS MAY DAMAGE THE DRIVE AND VOID THE WARRANTY!



**WARNING:** AC DRIVES GENERATE A LARGE AMOUNT OF HEAT WHICH MAY DAMAGE THE AC DRIVE. AUXILIARY COOLING METHODS ARE TYPICALLY REQUIRED IN ORDER NOT TO EXCEED MAXIMUM AMBIENT TEMPERATURES.

### MINIMUM CLEARANCES AND AIR FLOW

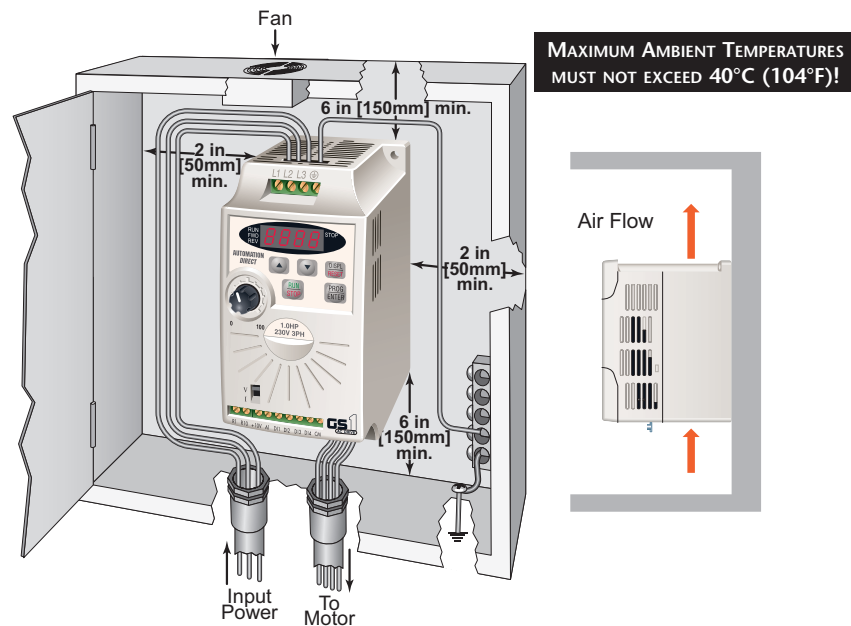

### GS1 AC Drive Dimensions

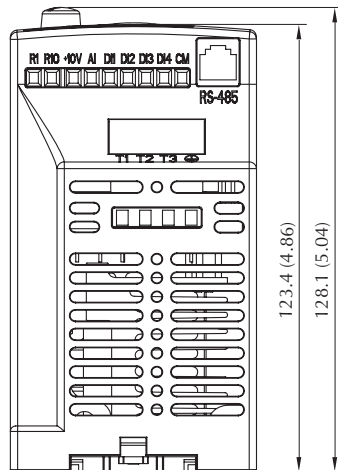
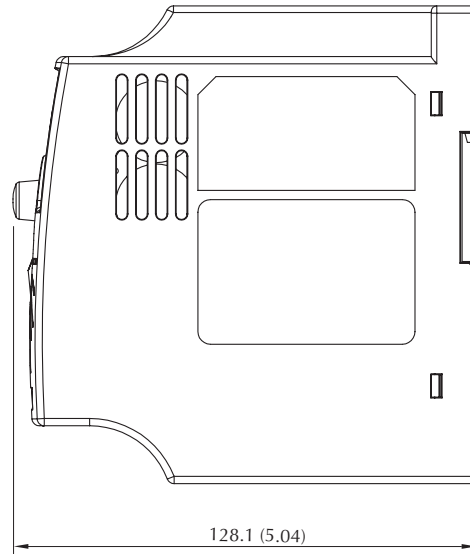
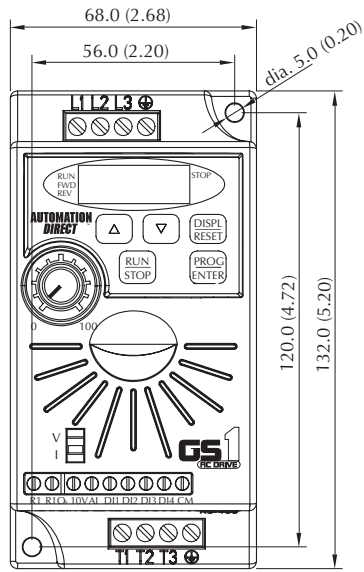

Unit: mm (in)

## GS1 Circuit Connections

### Danger!



**HAZARDOUS VOLTAGE!** BEFORE MAKING ANY CONNECTION TO THE AC DRIVE, DISCONNECT ALL POWER TO THE AC DRIVE, AND WAIT FIVE MINUTES FOR DC BUS CAPACITORS TO DISCHARGE.



**WARNING:** ANY ELECTRICAL OR MECHANICAL MODIFICATION TO THIS EQUIPMENT WITHOUT PRIOR WRITTEN CONSENT OF AUTOMATIONDIRECT.COM INC. WILL VOID ALL WARRANTIES, MAY RESULT IN A SAFETY HAZARD, AND MAY VOID THE UL LISTING.

#### WIRING NOTES: PLEASE READ PRIOR TO INSTALLATION.



**WARNING:** DO NOT CONNECT THE AC INPUT POWER TO THE T1, T2, AND T3 OUTPUT TERMINALS. THIS WILL DAMAGE THE AC DRIVE.



**WARNING:** TIGHTEN ALL SCREWS TO THE PROPER TORQUE RATING. SEE "MAIN CIRCUIT WIRING" LATER IN THIS CHAPTER.

- 1) During installation, follow all local electrical, construction, and safety codes for the country in which the AC drive is to be installed.
- 2) Make sure the appropriate protective devices (circuit breaker or fuses) are connected between the power supply and AC drive.
- 3) Make sure that the leads are connected correctly and the AC drive is properly grounded.
- 4) Use ground leads that comply with AWG/MCM standards, and keep them as short as possible.
- 5) The use of contactors or disconnect switches *for run/stop control* of the AC drive and motor *will reduce the operating life cycle of the AC drive.*  
*Cycling a power circuit switching device while the AC drive is in run mode should be done only in emergency situations.*

The installation of contactors or disconnects to isolate the motor during maintenance, though permissible, is not recommended. Opening contactors or disconnects while the drive is running will reduce the life cycle of the drive and may immediately damage the inverter section of the drive!

- 6) Multiple GS1 units can be installed in one location. All the units should be grounded directly to a common ground terminal. The GS1 ground terminals may also be connected in parallel, as shown in the figure below. Make sure there are no ground loops.

Correct



Incorrect

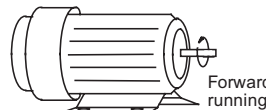

- 7) When the AC drive output terminals T1, T2, and T3 are connected to the motor terminals T1, T2, and T3, respectively, the motor will rotate counterclockwise (as viewed from the shaft end of the motor) when a forward operation command is received. To reverse the direction of motor rotation, switch the connections of any of the two motor leads.
- 8) Make sure that the power source is capable of supplying the correct voltage and required current to the AC drive.
- 9) Do not attach or remove wiring when power is applied to the AC drive.
- 10) Do not monitor the signals on the circuit board while the AC drive is in operation.
- 11) For single-phase, 115V class AC drives, AC power must be connected to terminals L1 and L2. For the single-phase, 230V class AC drives, the AC power can be connected to any two of the three input terminals L1, L2, or L3.



**NOTE:** This AC drive is not intended for use with single-phase motors.

- 12) Route the power and control wires separately, or at 90 degree angle to each other.
- 13) When using a GFCI (Ground Fault Circuit Interrupt), select current sensor with sensitivity of 200mA, and not less than 0.1-second detection to avoid nuisance tripping.

**MOTOR OPERATION PRECAUTIONS**

- 1) When using the AC drive to operate a standard 3-phase induction motor, the energy loss is greater than for an inverter duty motor.
- 2) Avoid running a standard induction motor at low speed, which may cause the motor temperature to exceed the motor rating due to limited airflow produced by the motor’s fan.
- 3) When the standard motor operates at low speed, the output load must be decreased.
- 4) If 100% output torque is desired at low speed, it may be necessary to use a special “inverter-duty” rated motor.

**SHORT CIRCUIT WITHSTAND**

Suitable for use on a circuit capable of delivering not more than 5,000 rms symmetrical amperes.

- For all 115V models, the maximum is 120 Volts.
- For all 230V Models, the maximum is 240 Volts.

**APPLICABLE CODES**

All GS1 Series AC drives are Underwriters Laboratories, Inc. (UL) and Canadian Underwriters Laboratories (cUL) listed, and therefore comply with the requirements of the National Electrical Code (NEC) and the Canadian Electrical Code (CEC).

Installation intended to meet the UL and cUL requirements must follow the instructions provided in “Wiring Notes” as a minimum standard. Follow all local codes that exceed UL and cUL requirements. Refer to the technical data label affixed to the AC drive and the motor nameplate for electrical data.

The “Fuses and Fuse Kits” section in Appendix A lists the recommended fuse part number for each GS1 Series part number. These fuses (or equivalent) must be used on all installations where compliance with U.L. standards is required.

**Circuit Protection Devices**

Short-circuit and ground-fault protection devices are essential to prevent costly damage to your AC Drive. Fuse kits, which include fuses and fuse blocks, are available from AutomationDirect for the GS1 Series AC Drives.

**MAXIMUM RECOMMENDED CIRCUIT PROTECTION DEVICES**

The chart below gives the maximum recommended fuses and circuit breakers for short-circuit and ground-fault protection of GS1 Series AC Drives. Fuses and circuit breakers smaller than those shown are permitted.

Maximum Recommended Circuit Protection Devices					
Drive Part #	V/HP/kW	Input Phases	Input Current	Fuse	Inverse-Time Circuit Breaker
GS1-10P2	115 / 0.25 / 0.2	1	6A	20A type A3T (300V)	20A
GS1-10P5	115 / 0.5 / 0.4	1	9A	30A type A3T (300V)	30A
GS1-20P2	230 / 0.25 / 0.2	1	4.9A	15A type A3T (300V)	15A
		3	1.9A	10A type A3T (300V)	10A
GS1-20P5	230 / 0.5 / 0.4	1	6.5A	25A type A3T (300V)	25A
		3	2.7A	10A type A3T (300V)	10A
GS1-21P0	230 / 1 / 0.7	1	9.7A	45A type A3T (300V)	45A
		3	5.1A	20A type A3T (300V)	20A
GS1-22P0	230 / 2 / 1.5	3	9.0A	25A type A3T (300V)	25A

*Recommended fuses are required for UL applications, and the specific fuses are available as shown in “Appendix A: Accessories”.*

*Recommended maximum fuses and circuit breakers are for protection of the AC drive. They may or may not also provide required motor branch circuit protection, depending upon the electrical code applicable to the installation.*

## Main Circuit Wiring

Main Circuit Terminals	
Terminal	Description
L1, L2, L3	Input Power
T1, T2, T3	AC Drive Output
⊕	Ground

Main Circuit Wiring Specifications			
AC Drive Model	Max. Current (Input/Output)	Wire Gauge	Torque
GS1-10P2	6A / 1.6A	12–16 AWG	5.5 kgf·cm
GS1-10P5	9A / 2.5A		
GS1-20P2 (1-phase)	4.9A / 1.6A		
GS1-20P2 (3-phase)	1.9A / 1.6A	12–14 AWG	5.5 kgf·cm
GS1-20P5 (1-phase)	6.5A / 2.5A		
GS1-20P5 (3-phase)	2.7A / 2.5A		
GS1-21P0 (1-phase)	9.7A / 4.2A		
GS1-21P0 (3-phase)	5.1A / 4.2A		
GS1-22P0	9A / 7.0A		

Wire Type: 75°C, copper only

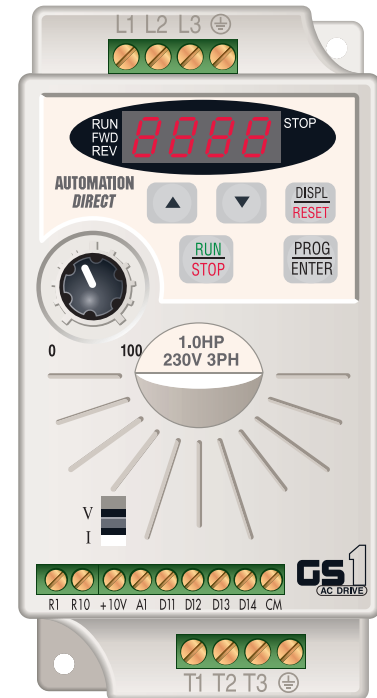

### INPUT POWER CONNECTIONS

#### 1-PHASE INPUT POWER CONNECTIONS\* \*\*

GS1 Top View (input power terminals)

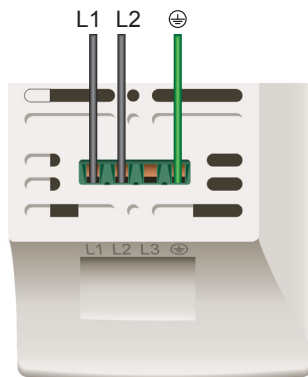

1-Phase Input Power*	
<b>115V Class**</b>	Single-phase: 100–120VAC ± 10%, 50/60Hz, ± 5%
<b>230V Class**</b>	Single-phase: 200–240VAC ± 10%, 50/60Hz ± 5%
* Only models GS1-10P2, GS1-10P5, GS1-20P2, GS1-20P5, and GS1-21P0 are rated for single-phase input power.	
** For 115V class single phase drives, AC power must be connected to terminals L1 and L2. For 230V class single phase drives, AC power can be connected to any two of the three terminals L1, L2 or L3.	

#### 3-PHASE INPUT POWER CONNECTIONS

GS1 Top View (input power terminals)

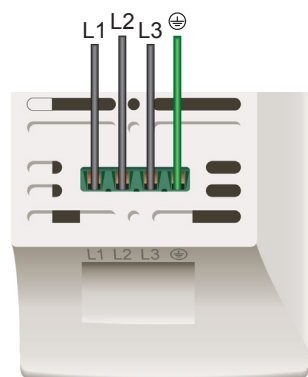

3-Phase Input Power	
<b>230V Class</b>	Three-phase: 200–240VAC ±10%, 50/60Hz ±5%

**OUTPUT POWER CONNECTIONS**

**GS1 Bottom View  
(output power terminals)**

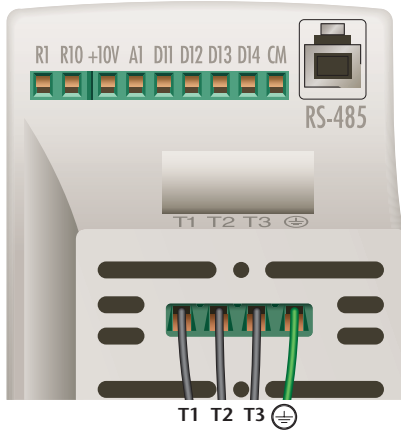

Output Power	
<b>115V Class Max Output Voltage</b>	Three phase 200–240VAC (input voltage x2)
<b>230V Class Max Output Voltage</b>	Three phase 200–240VAC (proportional to input voltage)

**Control Terminal Wiring**

**GS1 Bottom View (control terminals)**

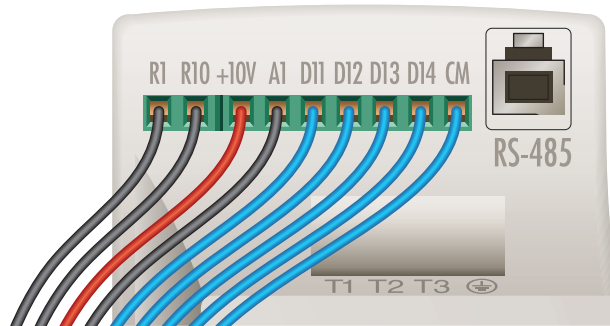

Control Circuit Terminals		
Terminal Symbol	Description	Remarks
<b>R1</b>	Relay Output Common	120VAC/24VDC @5A; 230VAC @2.5A
<b>R10</b>	Relay Output Normally Open	
<b>+10V</b>	Internal Power Supply	+10VDC (10mA maximum load)
<b>AI</b>	Analog Input	0 to +10 V (Max. Output Frequency) Input 0 to 20mA (Max. Output Frequency) Input 4 to 20mA (Max, Output Frequency) Input
<b>DI1</b>	Digital Input 1	Input voltage: Internally supplied (see Warning below) Maximum ON Voltage: 6V Minimum OFF Voltage: 11V Minimum ON Current: 2.5 mA Maximum OFF Current: 1mA (See "Basic Wiring Diagram" on next page.)
<b>DI2</b>	Digital Input 2	
<b>DI3</b>	Digital Input 3	
<b>DI4</b>	Digital Input 4	
<b>CM</b>	Common	
Control Terminal Wire Range: 24–12 AWG		
Control Terminal Tightening Torque: 5kgf·cm [4lbf·in]		



**NOTE:** Use twisted-shielded, twisted-pair or shielded-lead wires for the control signal wiring. Run all signal wiring in a separate steel conduit. The shield wire should only be connected at the AC drive. Do not connect shield wire on both ends.



**WARNING:**  
Do NOT connect external voltage sources to the digital inputs. Permanent damage may result.



## Basic Wiring Diagram



**NOTE:** Users must connect wiring according to the circuit diagram shown below.



**WARNING:** DO NOT PLUG A MODEM OR TELEPHONE INTO THE GS1 RJ-12 SERIAL COMM PORT, OR PERMANENT DAMAGE MAY RESULT. TERMINALS 1 AND 2 MUST NOT BE USED AS A POWER SOURCE FOR YOUR COMMUNICATION CONNECTION.

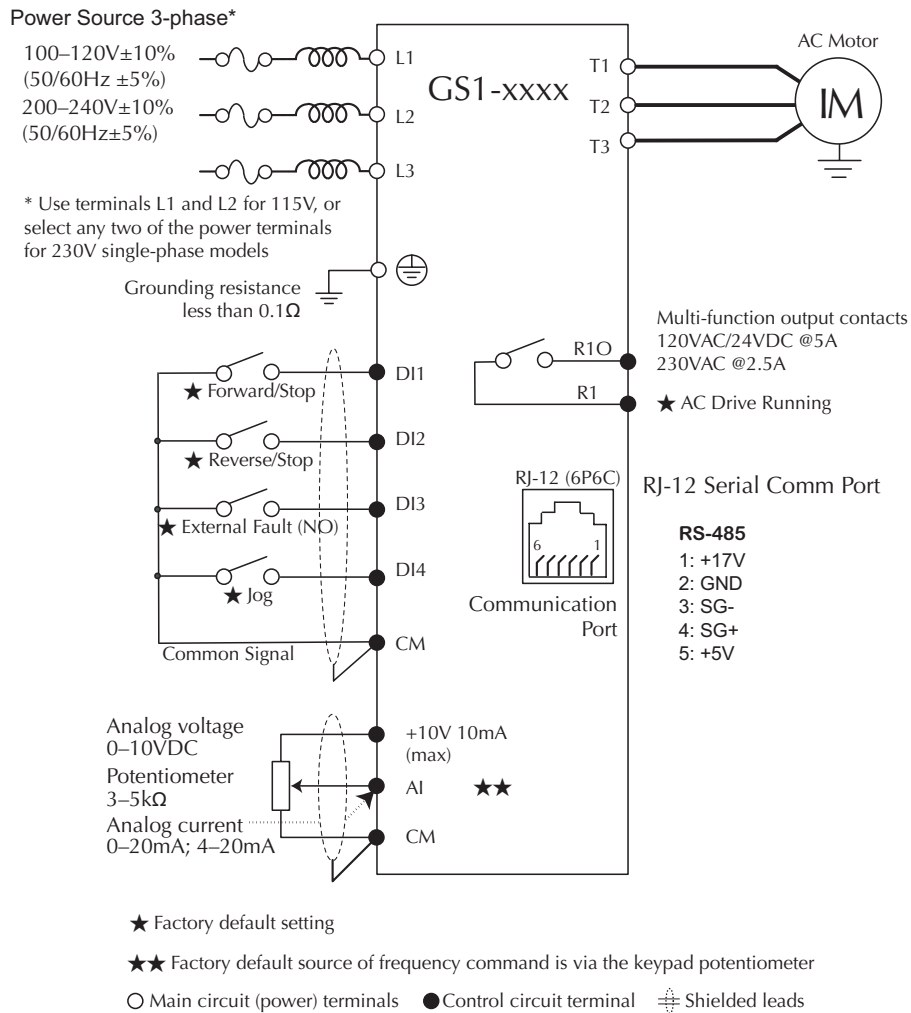

## External Wiring and Accessories



**WARNING:** THE INSTALLATION OF CONTACTORS OR DISCONNECTS TO ISOLATE THE MOTOR DURING MAINTENANCE, THOUGH PERMISSIBLE, IS **NOT** RECOMMENDED. OPENING CONTACTORS OR DISCONNECTS WHILE THE DRIVE IS RUNNING WILL REDUCE THE LIFE CYCLE OF THE DRIVE AND MAY IMMEDIATELY DAMAGE THE INVERTER SECTION OF THE DRIVE!



**WARNING:** WE STRONGLY RECOMMEND THAT YOU DO **NOT** USE A CONTACTOR BETWEEN THE AC DRIVE AND THE MOTOR, UNLESS THERE IS AN INTERLOCK TO OPEN THE CONTACTOR WHEN THE DRIVE IS NOT RUNNING.

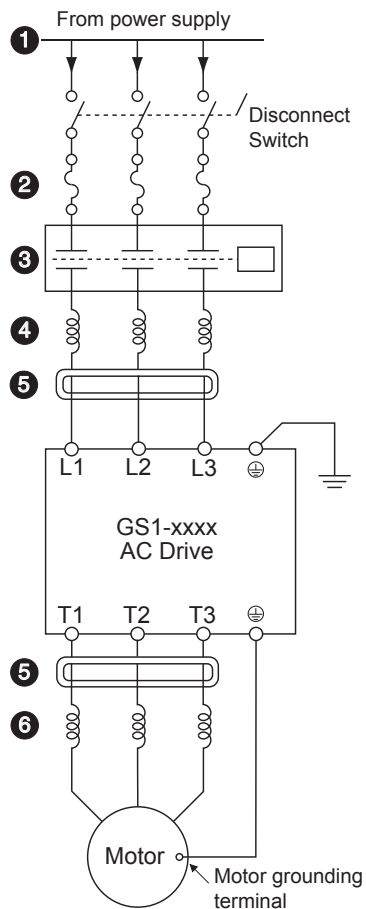

### 1 Power Supply

Please follow the specific power supply requirements shown in Chapter 1.

### 2 Fuses

Input fuses protect the AC drive from excessive input current due to line surges, short circuits, and ground faults. They are recommended for all installations and may be required for UL-listed installations.

### 3 Contactor (Optional)

**Do NOT use a contactor or disconnect switch for run/stop control of the AC drive and motor.** This will reduce the operating life cycle of the AC drive. Cycling a power circuit switching device while the AC drive is in run mode should be done only in emergency situations.

### 4 AC Line Reactor – Input Side (Optional)

Input line reactors protect the AC drive from transient overvoltage conditions typically caused by utility capacitor switching. Input line reactors also reduce harmonics associated with AC drives, and are recommended for all installations.

### 5 RF Filter (Optional)

RF filters reduce the radio frequency interference or noise on the input or output side of the inverter.

### 6 AC Line Reactor – Output Side (Optional)

Output line (load) reactors protect the motor insulation against AC drive short circuits and IGBT reflective wave damage, and also “smooth” the motor current waveform, allowing the motor to run cooler. They are *recommended for operating “non-inverter-duty” motors, and when the length of wiring between the AC drive and motor exceeds 75ft.*



Please refer to Appendix A for specifications on GS1 AC Drive Accessories.