

# INSTALLATION AND WIRING

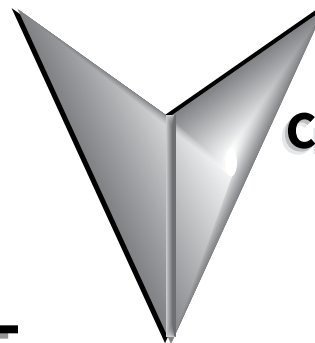

## CHAPTER

# 2

### CONTENTS OF THIS CHAPTER

<i>Ambient Conditions</i> . . . . .	.2-2
<i>Storage Conditions</i> . . . . .	.2-2
<i>Installation</i> . . . . .	.2-3
<i>Minimum Clearances and Air Flow</i> . . . . .	.2-3
<i>Dimensions</i> . . . . .	.2-4
<i>Frame A</i> . . . . .	.2-4
<i>Frame A with Fan</i> . . . . .	.2-5
<i>Frame B</i> . . . . .	.2-6
<i>Frame C</i> . . . . .	.2-7
<i>Frame D</i> . . . . .	.2-8
<i>Frame E</i> . . . . .	.2-9
<i>Frame F</i> . . . . .	.2-10
<i>Circuit Connections</i> . . . . .	.2-11
<i>Danger!</i> . . . . .	.2-11
<i>Wiring Notes: PLEASE READ PRIOR TO INSTALLATION:</i> . . . . .	.2-11
<i>Motor Operation Precautions</i> . . . . .	.2-12
<i>Short Circuit Withstand (SCCR)</i> . . . . .	.2-12
<i>Applicable Codes</i> . . . . .	.2-12
<i>Terminal Wiring Diagrams</i> . . . . .	.2-13
<i>Main Circuit Wiring</i> . . . . .	.2-17
<i>Power Wiring Diagrams</i> . . . . .	.2-18
<i>Drives under 20hp</i> . . . . .	.2-18
<i>Drives 20-30hp (230VAC) &amp; 20-60hp (460VAC)</i> . . . . .	.2-18
<i>Drives 40-50hp (230VAC) &amp; 75-100hp (460VAC)</i> . . . . .	.2-19
<i>Control Terminal Designations</i> . . . . .	.2-20
<i>Control Wiring Diagram – Sinking Inputs</i> . . . . .	.2-21
<i>Control Wiring Diagram – Sourcing Inputs</i> . . . . .	.2-22
<i>External Accessories</i> . . . . .	.2-23

## AMBIENT CONDITIONS

### AMBIENT ENVIRONMENTAL CONDITIONS FOR USE:

Ambient Conditions	
<b>Ambient Temperature</b>	-10°C to 40°C (14°F to 104°F)
<b>Relative Humidity</b>	0 to 90% (non-condensing)
<b>Atmosphere Pressure</b>	86 kPa to 106 kPa
<b>Vibration</b>	9.8 m/s <sup>2</sup> (1G) less than 10 Hz, 5.9 m/s <sup>2</sup> (0.6G) 10 to 60 Hz
<b>Installation Location</b>	Altitude 1000m or lower above sea level, keep from corrosive gas, liquid and dust
<b>Enclosure Rating</b>	IP20: Protection against contact by fingers. Protection against medium-size foreign objects

## STORAGE CONDITIONS

The AC drives should be kept in their shipping cartons or crates until they are installed. In order to retain their warranty coverage, they should be stored as described below if they are not to be installed and used within three months.

- Store in a clean and dry location free from direct sunlight and corrosive fumes.
- For storage of longer than 3 months, store within an ambient temperature range of -20 °C to 30 °C (-4°F to 86°F).
- For storage of 3 months or less, store within an ambient temperature range of -20 °C to 60 °C (-4°F to 140°F).
- Store within a relative humidity range of 0% to 90% and non-condensing environment.
- Store within an air pressure range of 86 kPa to 106 kPa.
- DO NOT store in an area with rapid changes in temperature. (It may cause condensation and frost.)
- DO NOT place directly on the ground.



*If the drive is stored or is otherwise unused for more than a year, the drive's internal DC link capacitors should be recharged before use. Otherwise, the capacitors may be damaged when the drive starts to operate. We recommend recharging the capacitors of any unused drive at least once per year. (Refer to Chapter 6, "Maintenance and Troubleshooting" for information about recharging DC link capacitors.)*

## INSTALLATION

Install the AC drive in an enclosure that is specifically designed to house electrical and electronic control equipment. Provide proper spacing within the enclosure to allow the dissipation of heat produced by the drive and any other included electrical and electronic equipment. Ventilation or air conditioning may also be required, depending upon the application.



**WARNING: FAILURE TO OBSERVE THESE PRECAUTIONS MAY DAMAGE THE DRIVE AND VOID THE WARRANTY!**

Improper installation of the AC drive will greatly reduce its life. Observe the following precautions when installing the drive:

- Do not mount the AC drive near heat-radiating elements or in direct sunlight.
- Do not install the AC drive in a place subjected to high temperature, high humidity, excessive vibration, corrosive gases or liquids, or airborne dust or metallic particles.
- Mount the AC drive securely on a flat, rigid, non-flammable surface.
- Mount the AC drive vertically and do not restrict the air flow to the heat sink fins.



**WARNING: AC DRIVES GENERATE A LARGE AMOUNT OF HEAT WHICH MAY DAMAGE THEM. AUXILIARY COOLING METHODS ARE TYPICALLY REQUIRED IN ORDER NOT TO EXCEED MAXIMUM AMBIENT TEMPERATURES.**

### MINIMUM CLEARANCES AND AIR FLOW

#### DIAGRAM DIRECTIONAL ARROWS

- Air Inflow: Blue Arrow → →
- Air Outflow: Red Arrow → →
- Distance: Black Arrows ↔ ↔

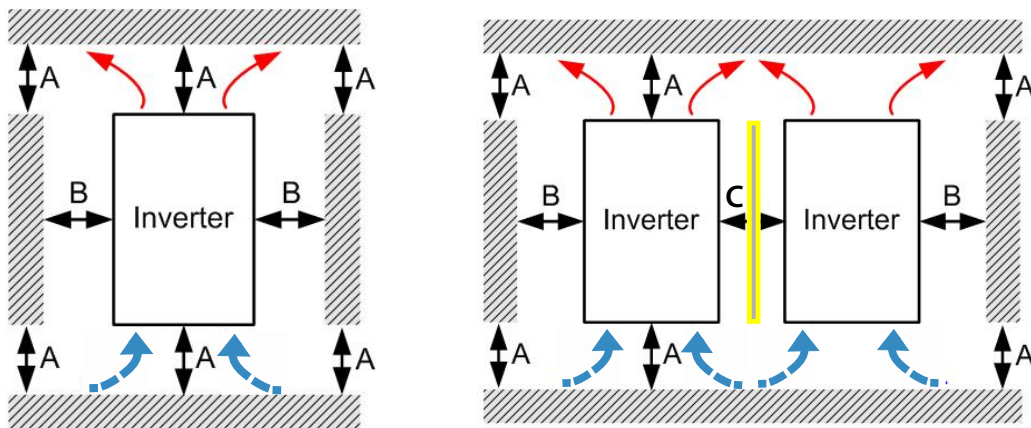

**WARNING: MAXIMUM AMBIENT TEMPERATURES MUST NOT EXCEED 40°C (104°F)!**

Minimum Clearances				
Installation Method	HP	A [mm]	B [mm]	C [mm]
Single drive installation	1-5	150	50	-
	7.5-20	175	75	-
	25-75	200	75	-
	100	150	75	-
Side-by-side horizontal installation	1-5	150	50	50
	7.5-20	175	75	75
	25-75	200	75	75
	100	150	75	100*

\* Add divider plate of equal height and depth of drives between each drive, as highlighted above at C. This is to prevent air from blowing directly from one drive into the other.

**DIMENSIONS**

UNITS = MM [IN]

**FRAME A**

Part Numbers: *GS3-21P0, GS3-22P0, GS3-41P0, GS3-42P0*

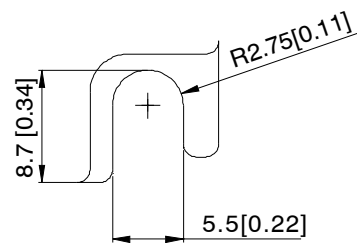
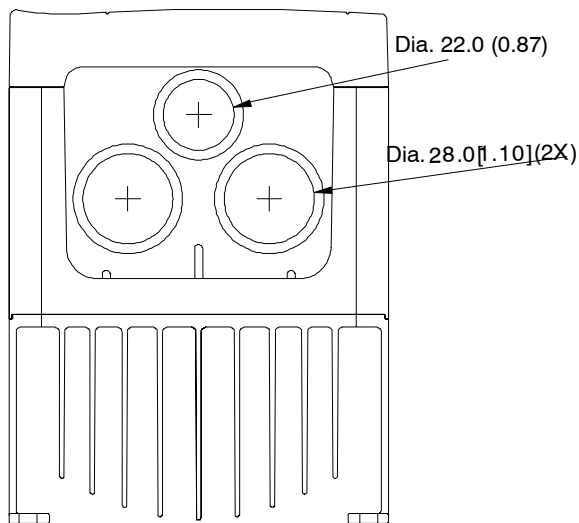
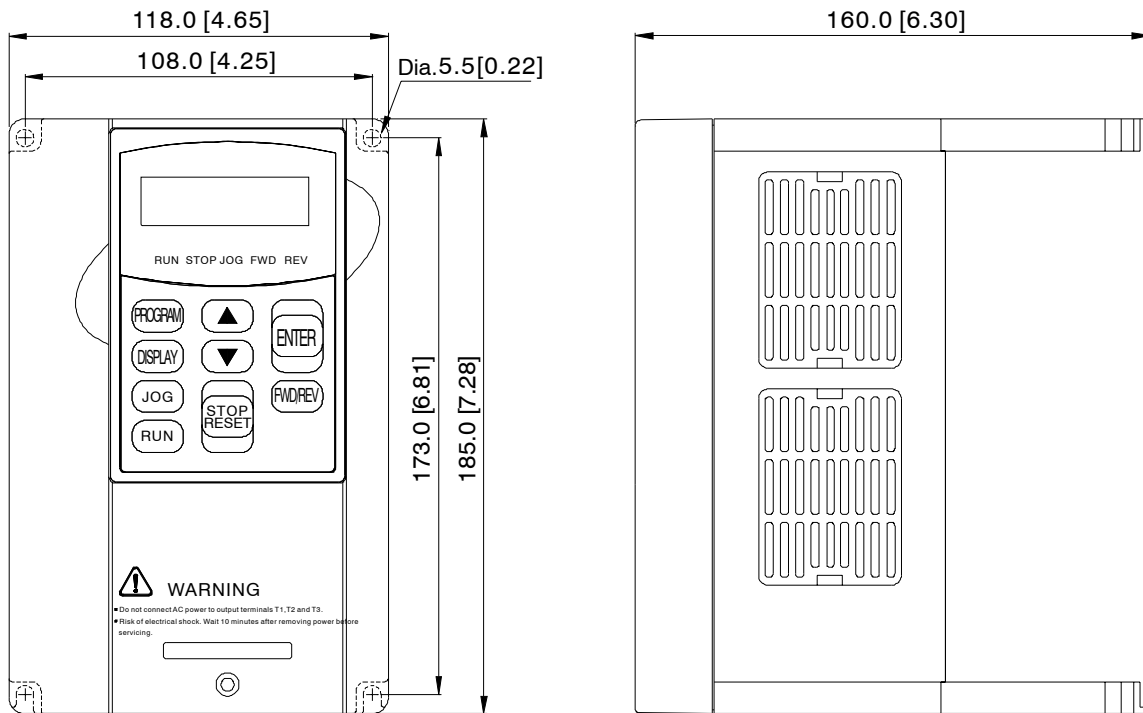

**DIMENSIONS (CONTINUED)**

**UNITS = MM [IN]**

**FRAME A WITH FAN**

**Part Numbers: GS3-43P0**

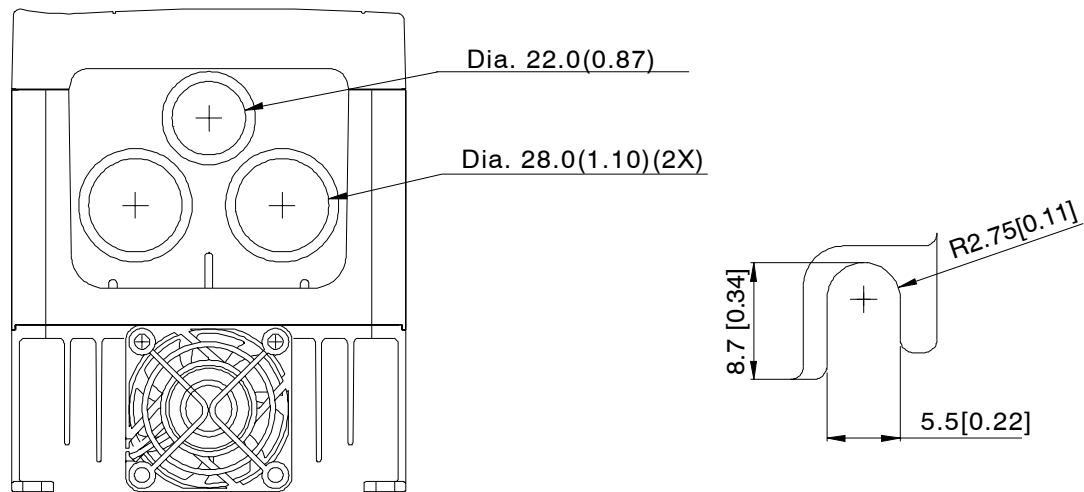
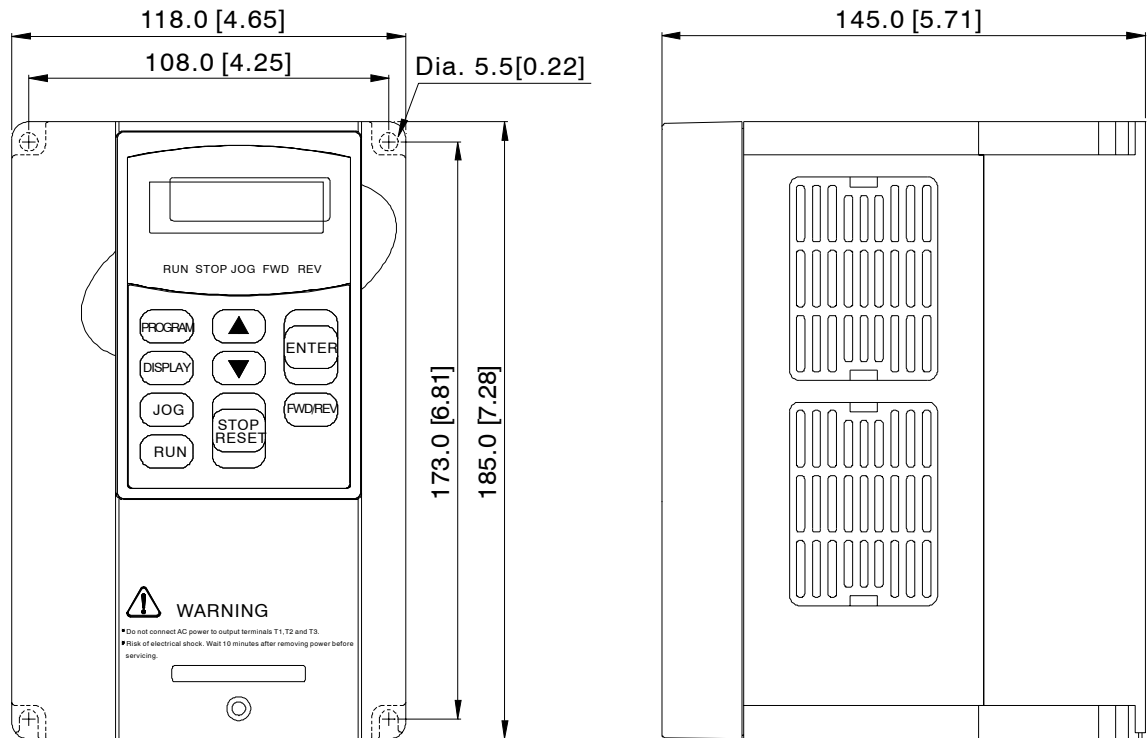

**DIMENSIONS (CONTINUED)**

**UNITS = MM [IN]**

**FRAME B**

**Part Numbers: GS3-23P0, GS3-25P0, GS3-45P0**

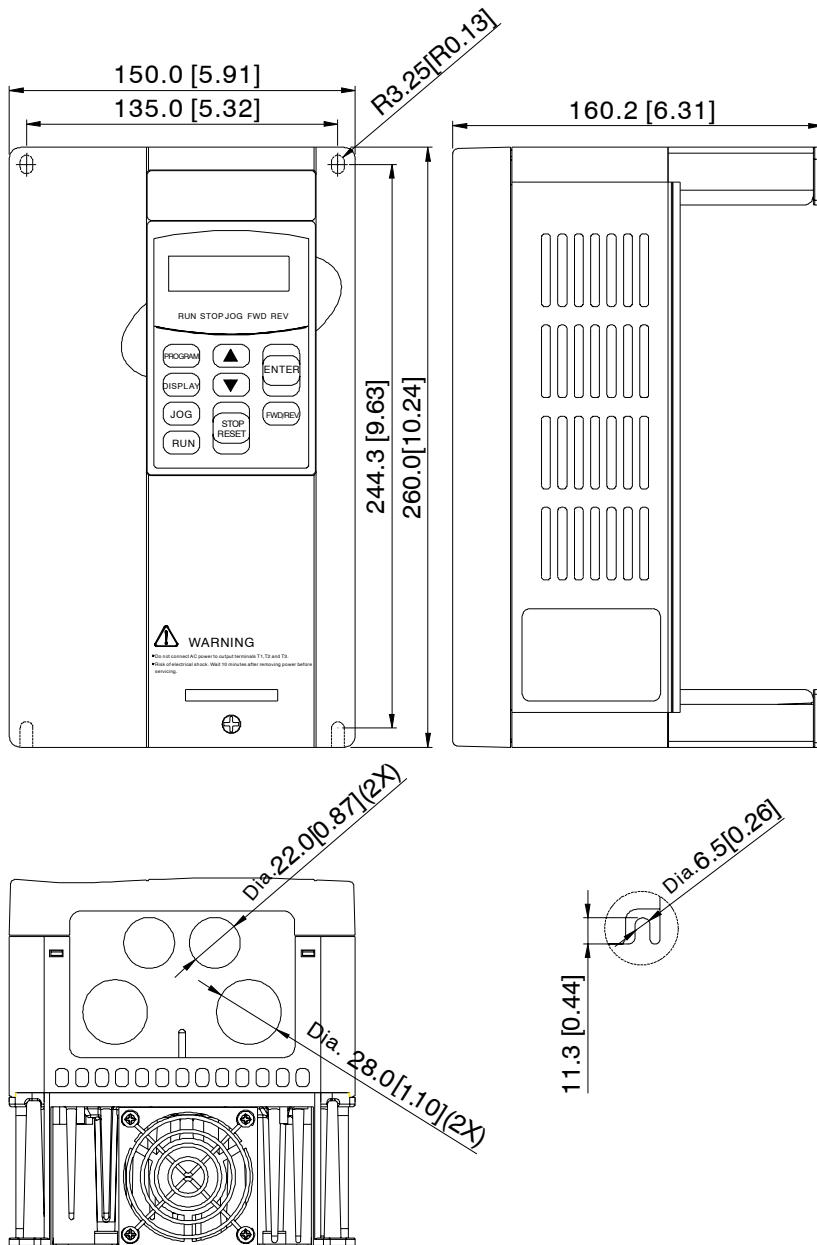

**DIMENSIONS (CONTINUED)**

**UNITS = MM [IN]**

**FRAME C**

**Part Numbers: GS3-27P5, GS3-2010, GS3-2015, GS3-47P5, GS3-4010, GS3-4015**

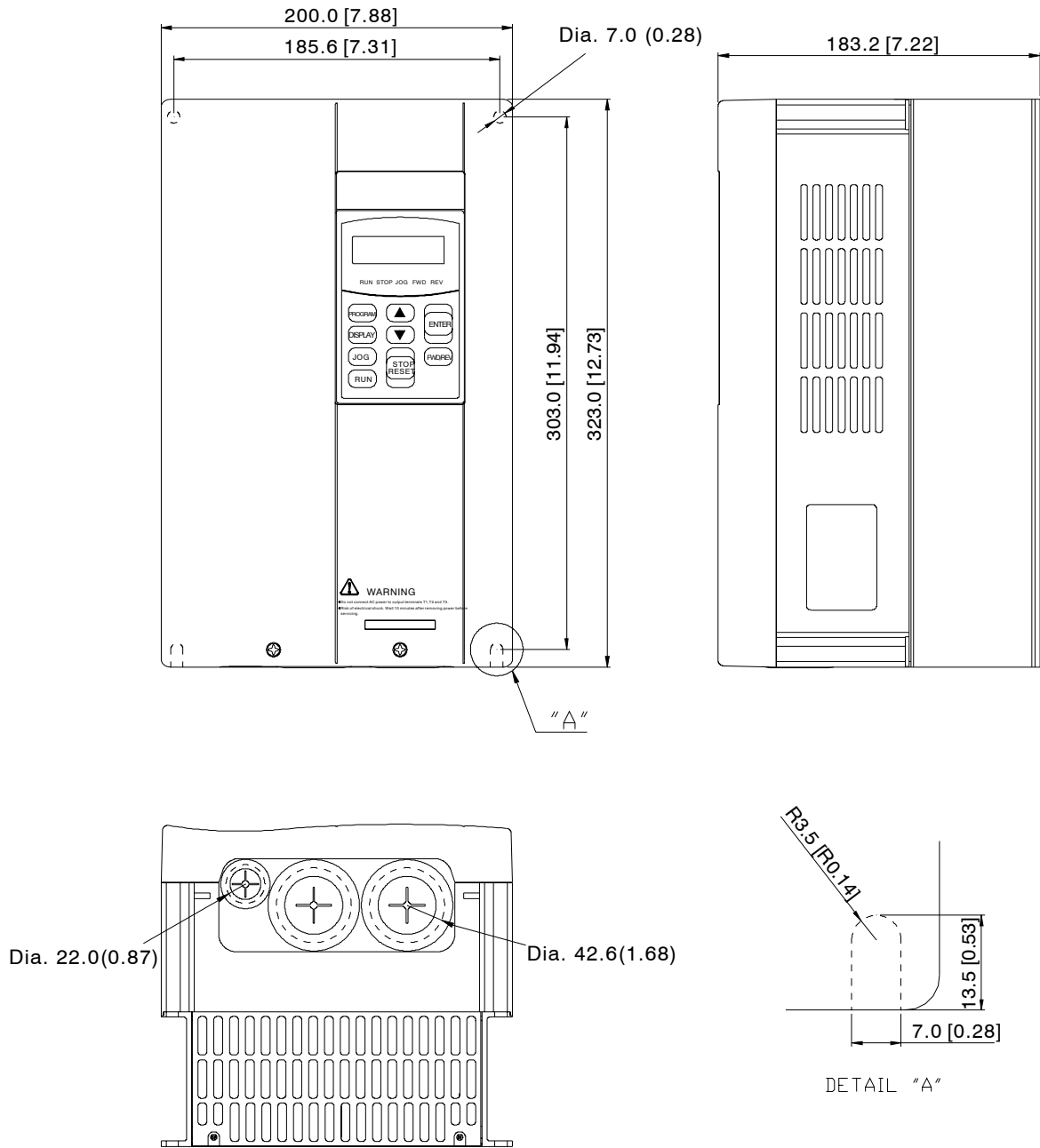

**DIMENSIONS (CONTINUED)**

**UNITS = MM [IN]**

**FRAME D**

**Part Numbers: GS3-2020, GS3-2025, GS3-2030, GS3-4020, GS3-4025, GS3-4030**

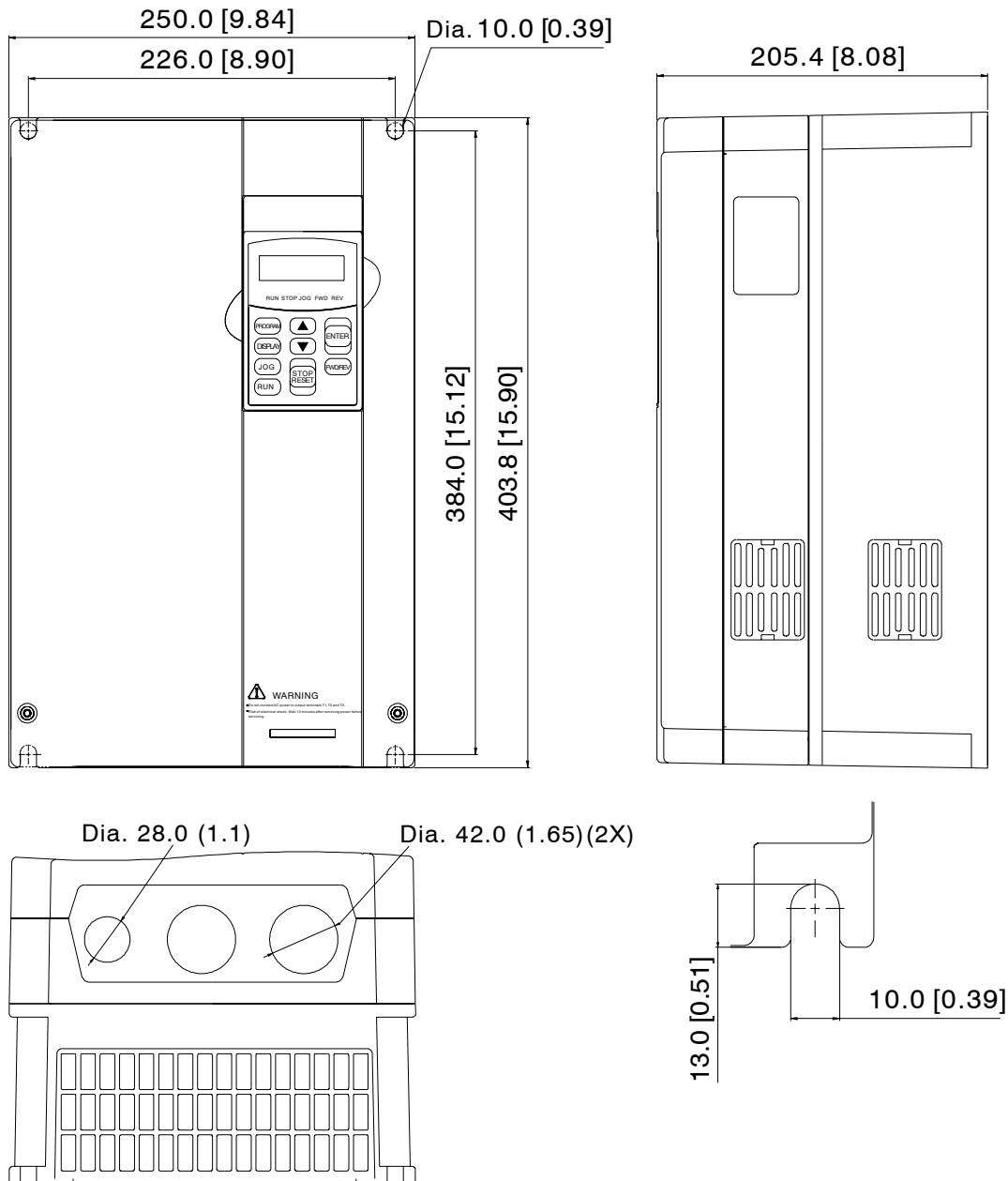



**DIMENSIONS (CONTINUED)**

**UNITS = MM [IN]**

**FRAME E**

*Part Numbers: GS3-2040, GS3-2050, GS3-4040, GS3-4050, GS3-4060*

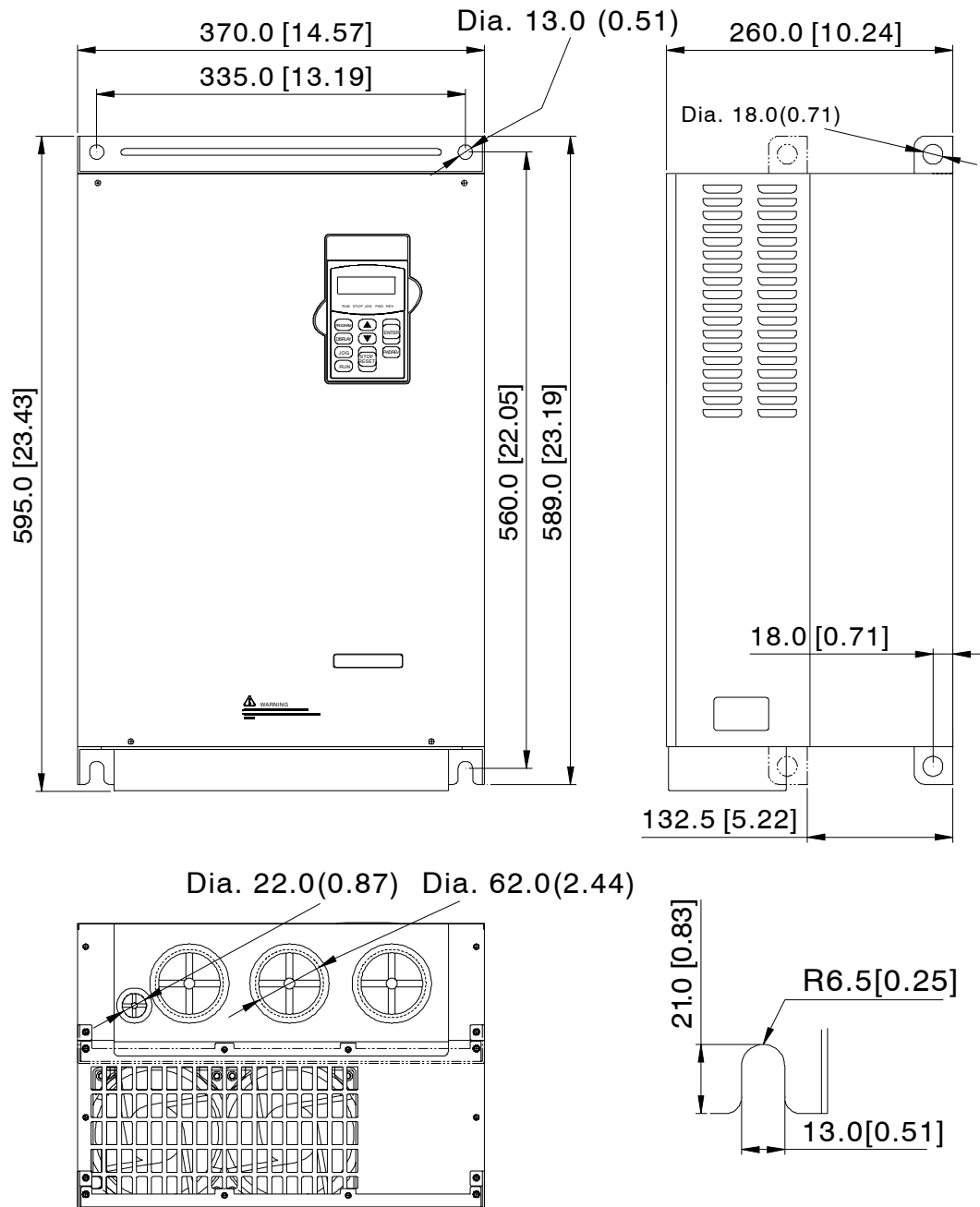

**DIMENSIONS (CONTINUED)**

**UNITS = MM [IN]**

**FRAME F**

*Part Numbers: GS3-4075, GS3-4100*

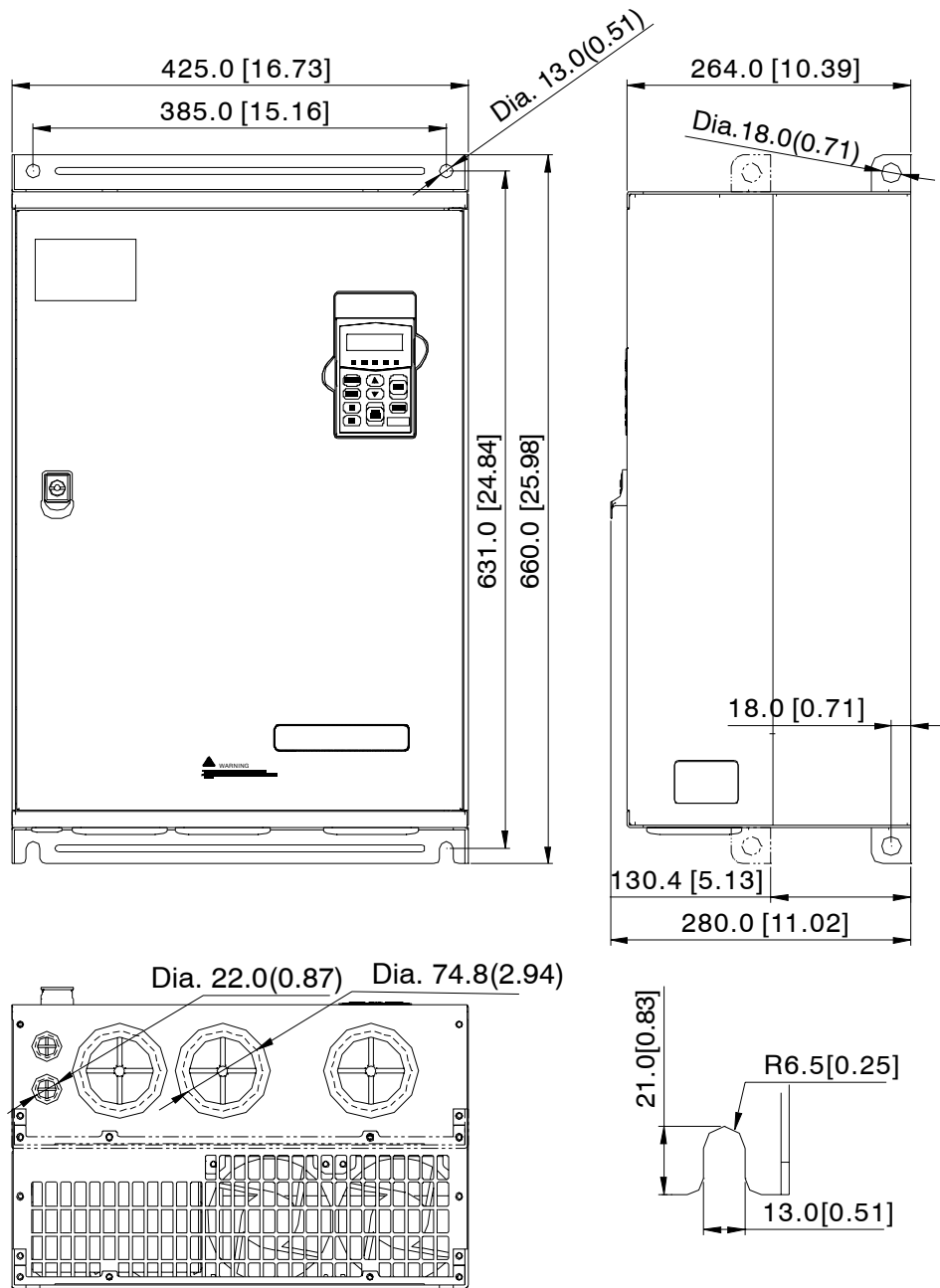

## CIRCUIT CONNECTIONS

## DANGER!



**HAZARDOUS VOLTAGE!** BEFORE MAKING ANY CONNECTION TO THE AC DRIVE, DISCONNECT ALL POWER TO THE AC DRIVE, AND WAIT FIVE MINUTES FOR DC BUS CAPACITORS TO DISCHARGE.



**WARNING:** ANY ELECTRICAL OR MECHANICAL MODIFICATION TO THIS EQUIPMENT WITHOUT PRIOR WRITTEN CONSENT OF AUTOMATIONDIRECT.COM, INC. WILL VOID ALL WARRANTIES, MAY RESULT IN A SAFETY HAZARD, AND MAY VOID THE UL LISTING.



**WARNING:** DO NOT CONNECT THE AC INPUT POWER TO THE T1, T2, AND T3 OUTPUT TERMINALS. DOING THIS WILL DAMAGE THE AC DRIVE.



**WARNING:** TIGHTEN ALL SCREWS TO THE PROPER TORQUE RATING. SEE "MAIN CIRCUIT WIRING" LATER IN THIS CHAPTER.

**WIRING NOTES: PLEASE READ PRIOR TO INSTALLATION:**

- 1) During installation, follow all local electrical, construction, and safety codes for the country in which the AC drive is to be installed.
- 2) Make sure the appropriate protective devices (circuit breaker or fuses) are connected between the power supply and AC drive.
- 3) Make sure that the leads are connected correctly and the AC drive is properly grounded. (Ground resistance should not exceed 0.1Ω.)
- 4) Use ground leads that comply with AWG/MCM standards and keep them as short as possible.
- 5) Do not use a power circuit contactor or disconnect switch for run/stop control of the AC drive and motor. This will reduce the operating life cycle of the AC drive. Cycling a power circuit switching device while the AC drive is in run mode should be done only in emergency situations.
- 6) Multiple DURAPULSE GS3 units can be installed in one location. All of the units should be grounded directly to a common ground terminal. The DURAPULSE GS3 ground terminals may also be connected in parallel, as shown in the figure below. Make sure there are no ground loops.

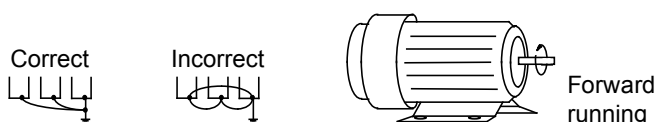

- 7) When the AC drive output terminals T1, T2, and T3 are connected to the motor terminals T1, T2, and T3, respectively, the motor will rotate counterclockwise (as viewed from the shaft end of the motor) when a forward operation command is received. To reverse the direction of motor rotation, switch the connections of any of the two motor leads.
- 8) Make sure that the power source is capable of supplying the correct voltage and required current to the AC drive.
- 9) Do not attach or remove wiring when power is applied to the AC drive.
- 10) Do not inspect components unless inside "POWER" lamp is turned off.
- 11) Do not monitor the signals on the circuit board while the AC drive is in operation.
- 12) GS3 series DURAPULSE drives **cannot be used with single-phase motors.**
- 13) Route the power and control wires separately, or at 90 degree angle to each other.
- 14) If a filter is required for reducing EMI (Electro Magnetic Interference), install it as close as possible to the AC drive. EMI can also be reduced by lowering the Carrier Frequency.
- 15) If the AC drive is installed in a place where a load reactor is needed, install the filter close to the T1, T2, and T3 side of AC drive. Do not use a Capacitor, L-C Filter (Inductance-Capacitance), or R-C Filter (Resistance-Capacitance), unless approved by AutomationDirect.
- 16) When using a GFCI (Ground Fault Circuit Interrupt), select current sensor with sensitivity of 200mA, and not less than 0.1-second detection to avoid nuisance tripping.

**MOTOR OPERATION PRECAUTIONS**

- 1) When using the AC drive to operate a standard 3-phase induction motor, notice that the energy loss is greater than for an inverter duty motor.
- 2) Avoid running a standard induction motor at low speed, which may cause the motor temperature to exceed the motor rating due to limited airflow produced by the motor's fan.
- 3) When the standard motor operates at low speed, the output load must be decreased.
- 4) If **100% output torque** is desired at **low speed**, it may be necessary to use a special **“inverter-duty” rated motor**.

**SHORT CIRCUIT WITHSTAND (SCCR)**

Models through 50 hp are suitable for use on a circuit capable of delivering not more than 5,000 rms symmetrical amperes; 10,000A for models 60 hp through 100 hp. The maximum voltage is 240V for all 230V models, and 480V for all 460V models.

**APPLICABLE CODES**

All *DURAPULSE* GS3 AC drives are Underwriters Laboratories, Inc. (UL) and Canadian Underwriters Laboratories (cUL) listed, and therefore comply with the requirements of the National Electrical Code (NEC) and the Canadian Electrical Code (CEC).

Installation intended to meet the UL and cUL requirements must follow the instructions provided in “Wiring Notes” as a minimum standard. Follow all local codes that exceed UL and cUL requirements. Refer to the technical data label affixed to the AC drive and the motor nameplate for electrical data. The “Circuit Protection Devices” section in Appendix A, lists the recommended fuse part number for each *DURAPULSE* GS3 part number. These fuses (or equivalent) must be used on all installations where compliance with U.L. standards is required.

**TERMINAL WIRING DIAGRAMS**

*GS3-21P0, GS3-22P0, GS3-41P0, GS3-42P0, GS3-43P0*

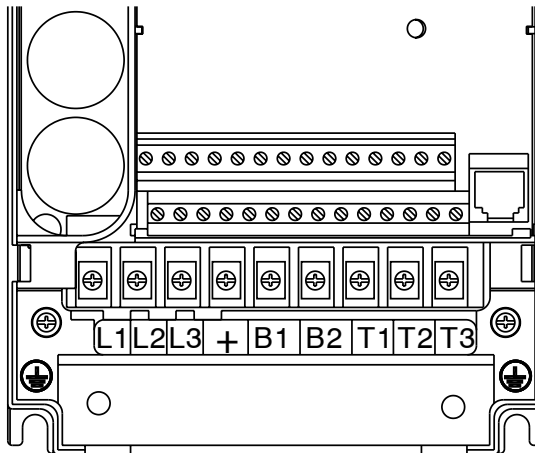

*GS3-23P0, GS3-25P0, GS3-45P0*

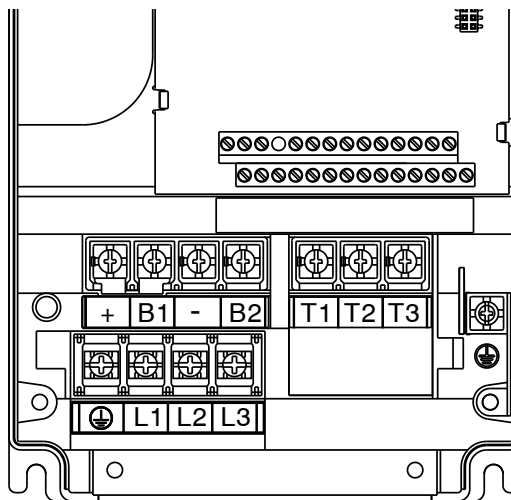

*GS3-27P5, GS3-47P5, GS3-2010, GS3-4010, GS3-2015, GS3-4015*

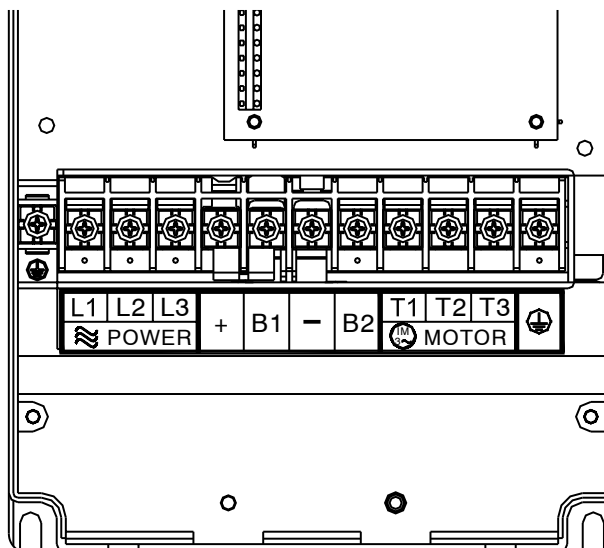

**TERMINAL WIRING DIAGRAMS (CONTINUED)**

GS3-2020, GS3-4020, GS3-2025, GS3-4025, GS3-2030, GS3-4030

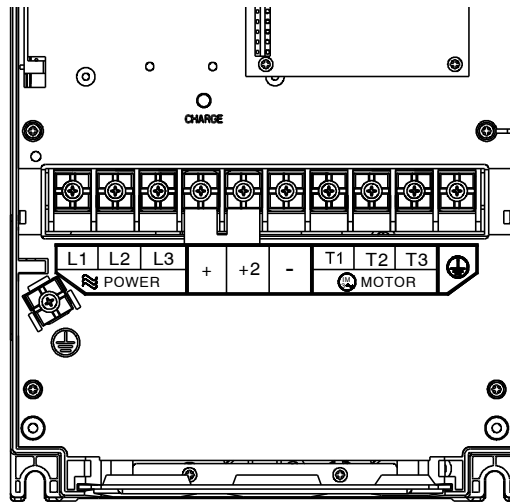

GS3-2040, GS3-2050

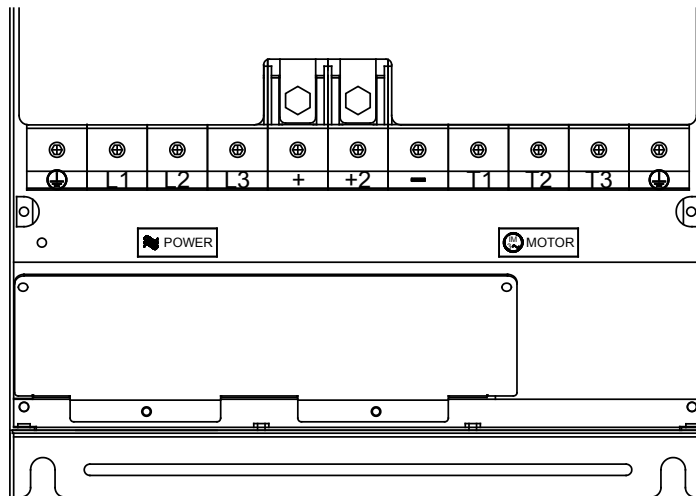

GS3-4040, GS3-4050, GS3-4060

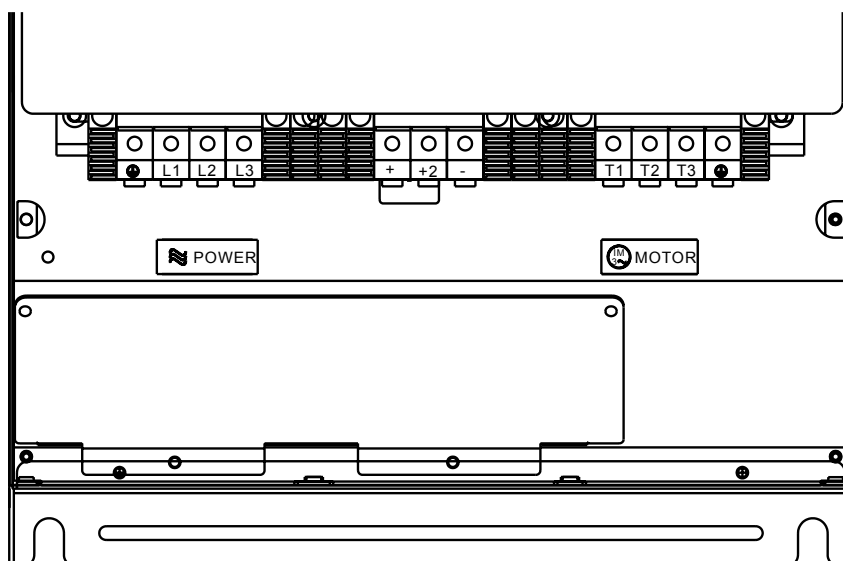

**TERMINAL WIRING DIAGRAMS (CONTINUED)**

**GS3-4075, GS3-4100**

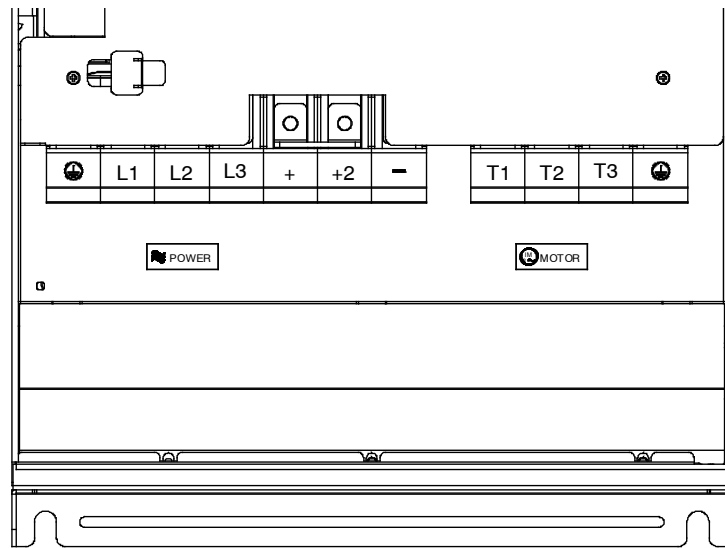

## MAIN CIRCUIT WIRING

Main Circuit Terminals	
<b>Terminal</b>	Description
<b>L1, L2, L3</b>	Input Power
<b>T1, T2, T3</b>	AC Drive Output
<b>B1, B2</b>	Braking Resistor Connection (Under 20HP)
<b>+2, - (negative)</b>	External Dynamic Brake Unit (20HP & Over)
	Ground

Main Circuit Wiring Specifications				
AC Drive Model	Input Current (A)	Output Current (A)	Wire Range (AWG)	Terminal Tightening Torque (kgf-cm)
GS3-21P0	5.7	5	10-18	18
GS3-22P0	7.6	7		
GS3-23P0	15.5	10		
GS3-25P0	20.6	17		
GS3-27P5	26	25	8-12	30
GS3-2010	34	33		
GS3-2015	50	49	2-8	40
GS3-2020	60	65		
GS3-2025	75	75		
GS3-2030	90	90	2/0-3/0	200
GS3-2040	110	120		
GS3-2050	142	145	10-18	18
GS3-41P0	3.2	2.7		
GS3-42P0	4.3	4.2		
GS3-43P0	5.9	5.5		
GS3-45P0	11.2	8.5	8-12	30
GS3-47P5	14	13		
GS3-4010	19	18	2-8	40
GS3-4015	25	24		
GS3-4020	32	32		
GS3-4025	39	38	2-4	57
GS3-4030	49	45		
GS3-4040	60	60	2/0-3/0	200
GS3-4050	63	73		
GS3-4060	90	91		
GS3-4075	130	110	2/0-3/0	200
GS3-4100	160	150		



**POWER WIRING DIAGRAMS**

**DRIVES UNDER 20HP**



Users must connect wiring according to the circuit diagram shown below.

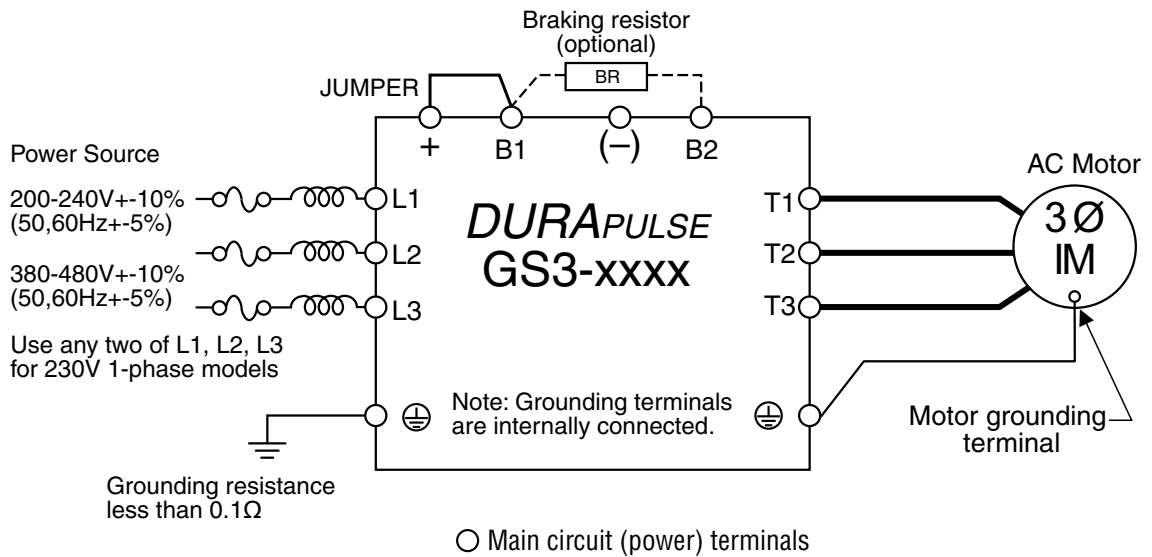

**DRIVES 20–30HP (230VAC) & 20–60HP (460VAC)**



Users must connect wiring according to the circuit diagram shown below.

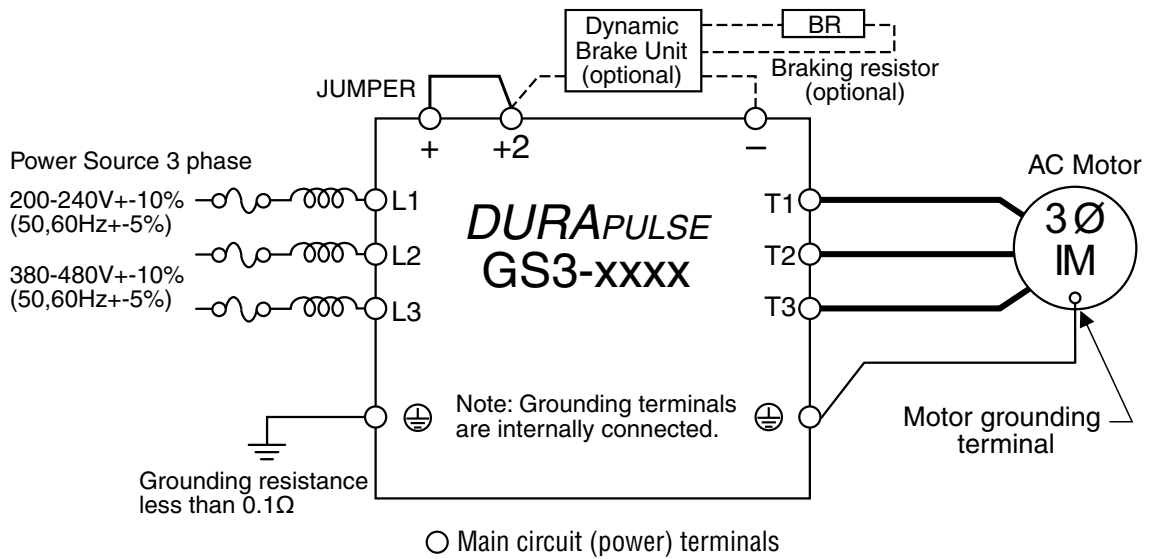

**POWER WIRING DIAGRAMS (CONTINUED)**

**DRIVES 40–50HP (230VAC) & 75–100HP (460VAC)**



Users must connect wiring according to the circuit diagram shown below.

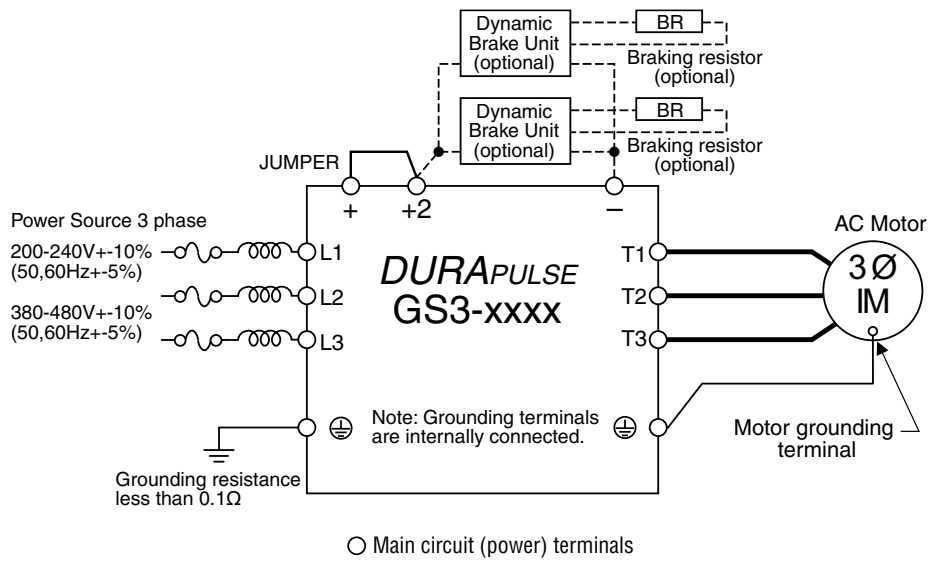

**CONTROL TERMINAL DESIGNATIONS**

Control Circuit Terminals		
Terminal Symbol	Description	Remarks
<b>+24V</b>	DC Voltage Source	(+24V, 20mA), used only for AC drive digital inputs wired for source mode operation
<b>DI1</b>	Digital Input 1	Input Voltage: Internally Supplied (see Warning below) Sink Mode: Low active, $V_{inL}$ Min = 0V, $V_{inL}$ Max = 15V; $I_{in}$ Min = 2.1mA, $I_{in}$ Max = 7.0mA Source Mode: High active, $V_{inH}$ Min = 8.5V, $V_{inH}$ Max = 24V; $I_{in}$ Min = 2.1mA, $I_{in}$ Max = 7.0mA Input response: 12–15 ms Also see "Basic Wiring Diagram" on the next pages.
<b>DI2</b>	Digital Input 2	
<b>DI3</b>	Digital Input 3	
<b>DI4</b>	Digital Input 4	
<b>DI5</b>	Digital Input 5	
<b>DI6</b>	Digital Input 6	
<b>DI7</b>	Digital Input 7	
<b>DI8</b>	Digital Input 8	
<b>DI9</b>	Digital Input 9	
<b>DI10</b>	Digital Input 10	
<b>DI11</b>	Digital Input 11	
<b>DCM</b>	Digital Common	
<b>+10V</b>	Internal Power Supply	+10VDC (10mA maximum load)
<b>AI1</b>	Analog Input	0 to +10 V input only
<b>AI2</b>	Analog Input	0 to 20 mA / 4 to 20 mA input
<b>AI3</b>	Analog Input	-10 to +10 V input only
<b>ACM</b>	Analog Common	
<b>R1O</b>	Relay Output 1 Normally Open	Resistive Load: 240VAC – 5A (N.O) / 3A (N.C.);    24VDC – 5A (N.O.) / 3A (N.C.) Inductive Load: 240VAC – 1.5A (N.O) / 0.5A (N.C);    24VDC – 1.5A (N.O) / 0.5A (N.C)
<b>R1C</b>	Relay Output 1 Normally Closed	
<b>R1</b>	Relay Output 1 Common	
<b>DO1</b>	Photocoupled digital output	12–48 VDC, 50 mA
<b>DO2</b>	Photocoupled digital output	
<b>DO3</b>	Photocoupled digital output	
<b>DOC</b>	Digital Output Common	
<b>FO</b>	Digital Frequency Output	Maximum 50mA @ 48VDC, Scalable squarewave, 50% duty cycle output
<b>AO</b>	Analog Output	0 to +10V, 2mA Output
Control Terminal Wire Range: 24–12 AWG		
Control Terminal Tightening Torque: 5kgf·cm [4lbf·in]		



**WARNING:** *DO NOT CONNECT EXTERNAL VOLTAGE SOURCES TO THE DIGITAL INPUTS. PERMANENT DAMAGE MAY RESULT.*



*Use twisted-shielded, twisted-pair or shielded-lead wires for the control signal wiring. It is recommended to run all signal wiring in a separate steel conduit. The shield wire should only be connected at the AC drive. Do NOT connect shield wire on both ends.*

## CONTROL WIRING DIAGRAM – SINKING INPUTS



Users must connect wiring according to the circuit diagram shown below.



**WARNING:** DO NOT PLUG A MODEM OR TELEPHONE INTO THE DURAPULSE GS3 RJ-12 SERIAL COMM PORT, OR PERMANENT DAMAGE MAY RESULT.

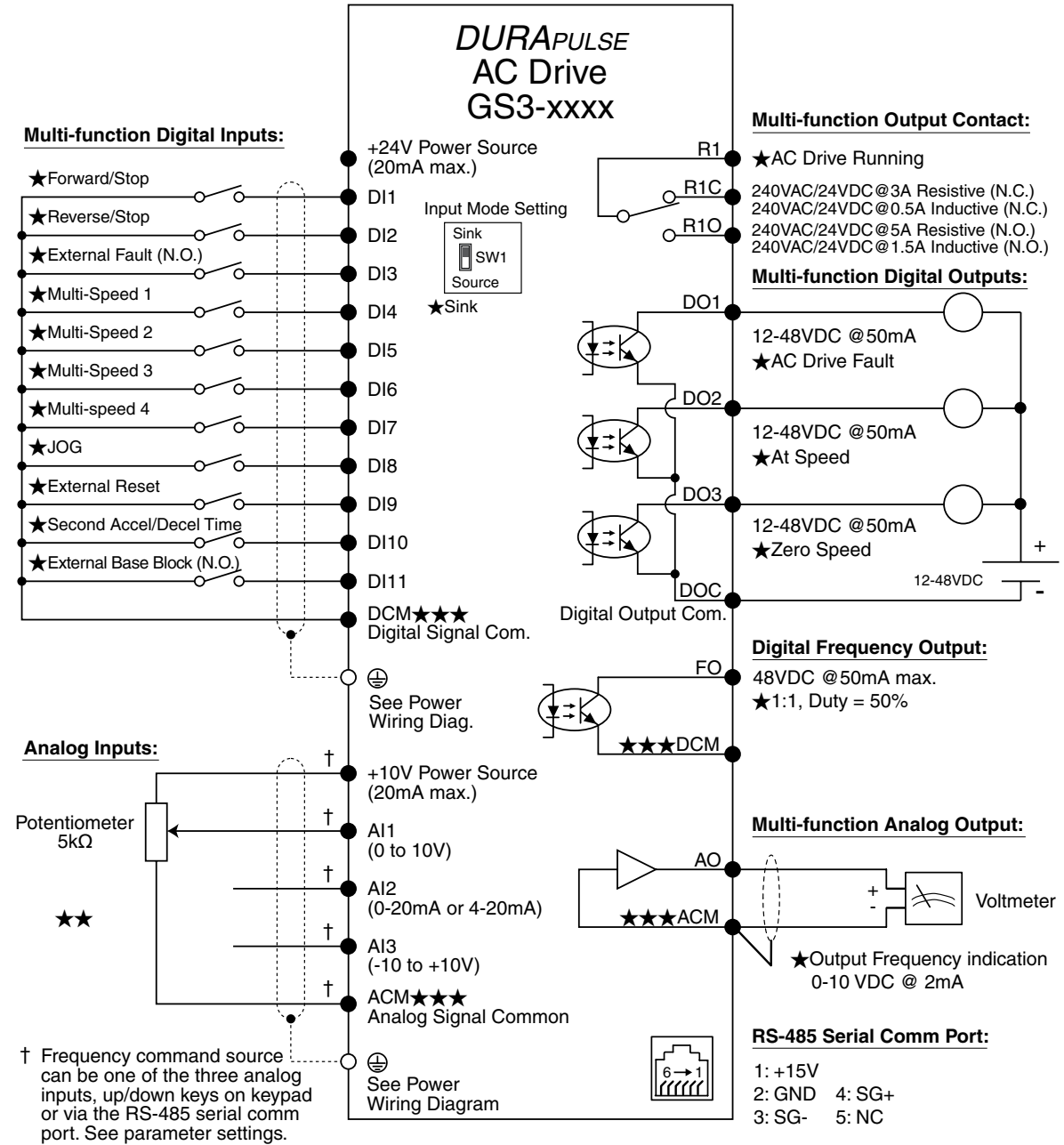

- ★ Factory default setting
- ★★ Factory default source of frequency command is via the keypad up/down keys
- ★★★ ACM and DCM are isolated from each other
- Main circuit (power) terminals ● Control circuit terminal Ⓢ Shielded leads

## CONTROL WIRING DIAGRAM – SOURCING INPUTS



Users must connect wiring according to the circuit diagram shown below.



**WARNING: DO NOT PLUG A MODEM OR TELEPHONE INTO THE DURAPULSE GS3 RJ-12 SERIAL COMM PORT, OR PERMANENT DAMAGE MAY RESULT.**

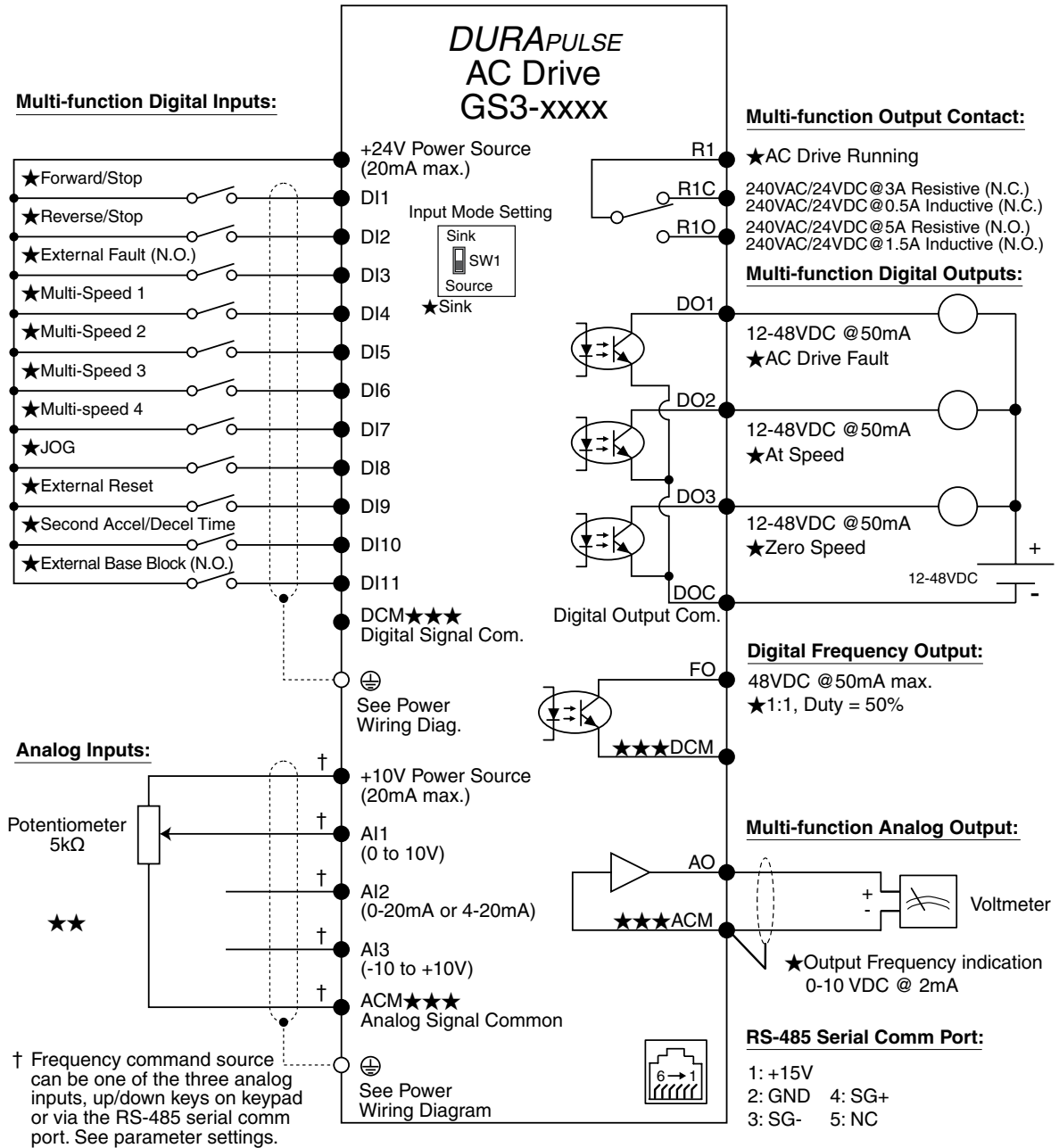

- ★ Factory default setting
- ★★ Factory default source of frequency command is via the keypad up/down keys
- ★★★ ACM and DCM are isolated from each other
- Main circuit (power) terminals ● Control circuit terminal Ⓢ Shielded leads

**EXTERNAL ACCESSORIES**

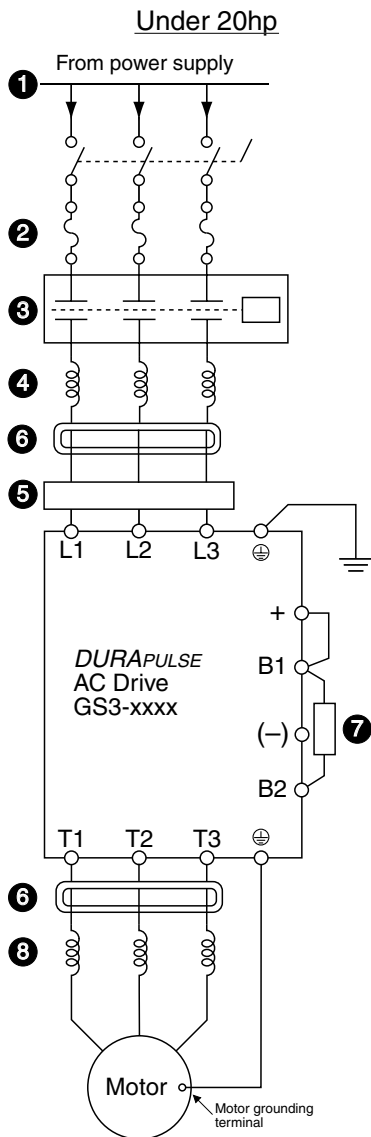

- 1 **Power Supply**  
Please follow the specific power supply requirements shown in Chapter 1.
- 2 **Fuses**  
Input fuses protect the AC drive from excessive input current due to line surges, short circuits, and ground faults. They are recommended for all installations and may be required for UL-listed installations.
- 3 **Contactor (Optional)**  
**Do NOT use a power circuit contactor or disconnect switch for run/stop control of the AC drive and motor.** This will reduce the operating life cycle of the AC drive. Cycling a power circuit switching device while the AC drive is in run mode should be done only in emergency situations.
- 4 **AC Line Reactor (Optional)**  
Input line reactors protect the AC drive from transient overvoltage conditions typically caused by utility capacitor switching. Input line reactors also reduce harmonics associated with AC drives, and are recommended for all installations.
- 5 **EMI filter (Optional)**  
Input EMI filters reduce electromagnetic interference or noise on the input side of the AC drive. They are required for CE compliance and recommended for installations prone to or sensitive to electromagnetic interference.
- 6 **RF filter (Optional)**  
RF filters reduce the radio frequency interference or noise on the input or output side of the inverter.
- 7 **Braking Resistor (Optional)**  
Dynamic braking allows the AC drive to produce additional braking (stopping) torque. AC drives can typically produce between 15% & 20% braking torque without the addition of any external components. Optional braking may be required for applications that have high inertia loads or require rapid deceleration.
- 8 **AC Line Reactor/Output Filter (Optional)**  
Output line (load) reactors protect the motor insulation against AC drive short circuits and IGBT reflective wave damage, and also “smooth” the motor current waveform, allowing the motor to run cooler. They are recommended for operating “non-inverter-duty” motors, and when the length of wiring between the AC drive and motor is less than 100 feet. Use Output filters if wiring exceeds 100 feet up to 1000 feet (max).



Please refer to Appendix A for specifications on DURApulse GS3 AC Drive Accessories.

**EXTERNAL ACCESSORIES (CONTINUED)**

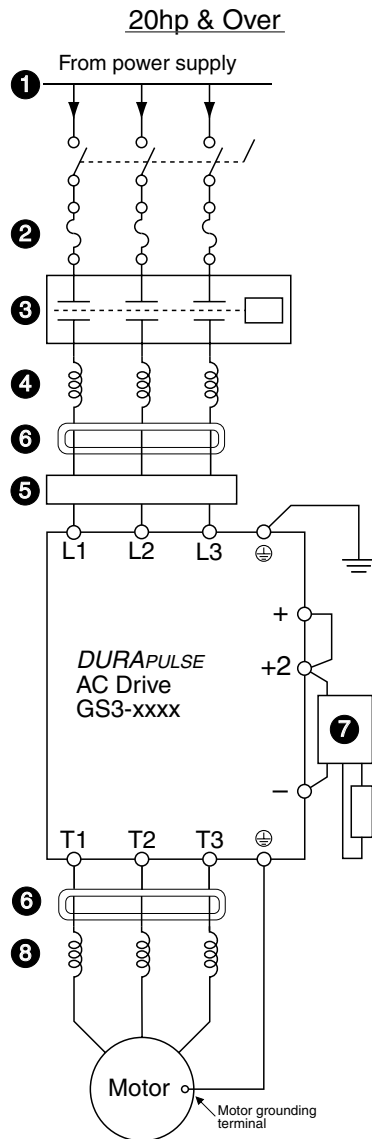

- 1 Power Supply**  
Please follow the specific power supply requirements shown in Chapter 1.
- 2 Fuses**  
Input fuses protect the AC drive from excessive input current due to line surges, short circuits, and ground faults. They are recommended for all installations and may be required for UL-listed installations.
- 3 Contactor (Optional)**  
**Do NOT use a power circuit contactor or disconnect switch for run/stop control of the AC drive and motor.** This will reduce the operating life cycle of the AC drive. Cycling a power circuit switching device while the AC drive is in run mode should be done only in emergency situations.
- 4 AC Line Reactor (Optional)**  
Input line reactors protect the AC drive from transient overvoltage conditions typically caused by utility capacitor switching. Input line reactors also reduce harmonics associated with AC drives, and are recommended for all installations.
- 5 EMI filter (Optional)**  
Input EMI filters reduce electromagnetic interference or noise on the input side of the AC drive. They are required for CE compliance and recommended for installations prone to or sensitive to electromagnetic interference.
- 6 RF filter (Optional)**  
RF filters reduce the radio frequency interference or noise on the input or output side of the inverter.
- 7 Braking Unit and Braking Resistor (Optional)**  
Dynamic braking allows the AC drive to produce additional braking (stopping) torque. AC drives can typically produce between 15% & 20% braking torque without the addition of any external components. Optional braking may be required for applications that have high inertia loads or require rapid deceleration.
- 8 AC Line Reactor/Output Filter (Optional)**  
Output line (load) reactors protect the motor insulation against AC drive short circuits and IGBT reflective wave damage, and also “smooth” the motor current waveform, allowing the motor to run cooler. They are recommended for operating “non-inverter-duty” motors, and when the length of wiring between the AC drive and motor is less than 100 feet. Use Output filters if wiring exceeds 100 feet up to 1000 feet (max).



Please refer to Appendix A for specifications on DURApulse GS3 AC Drive Accessories.

**BLANK  
PAGE**