

# Programming Examples

---

## In This Chapter. . . .

- DL05/105/DL205/D3-350/DL405 Application Examples
  - D3-340 Application Example
  - Allen-Bradley™ Application Examples
  - Troubleshooting
-

## Examples Using *Direct*LOGIC PLCs

### Register Usage

The OP-WINEDIT configuration software allows you to configure a panel to use a block of registers at a starting value that you define. For a DL05, DL105, DL205, D3-350 or DL405 CPU the recommended memory to use is the control relay registers starting at V40600. For the 305 family (except the D3-350), the recommended memory is the registers beginning at R16. Any block of registers within the data word range can be used.

The following table lists the control relay register addresses for CPUs.

Control Relay Registers for <i>Direct</i> LOGIC™ PLCs		
Family	CPU	Control Relay Registers
<i>Direct</i> LOGIC™ DL05	D0-05	V40600-V40637
<i>Direct</i> LOGIC™ DL105	F1-130	V40600-V40617
<i>Direct</i> LOGIC™ DL205	D2-230	V40600-V40617
	D2-240	V40600-V40617
	D2-250	V40600-V40677
<i>Direct</i> LOGIC™ DL305	D3-330/D3-330P	R16-R37
	D3-340	R016-R037 and R100-R106
	D3-350	V40600-V40677
<i>Direct</i> LOGIC™ DL405	D4-430	V40600-V40635
	D4-440	V40600-V40677
	D4-450	V40600-V40777

## Examples Using DL05, DL105, DL205, D3-350 and DL405

The following example programs use a PLC base address of V40600. The table below shows the control relay correlation for an OP-406 panel configured for a PLC base address of V40600.

Device	Lamp/LED On/Off	Lamp/LED Flash	Button Status	Force
B1	C0	C20	C40	C60
B2	C1	C21	C41	C61
B3	C2	C22	C42	C62
B4	C3	C23	C43	C63
L1	C10	C30		
L2	C11	C31		
L3	C12	C32		
L4	C13	C33		
L5	C14	C34		
L6	C15	C35		C75 (F3)
				C76 (F2)
				C77 (F1)

**Turning on a Lamp** Turning on a lamp requires activating the associated control relay coil. In the figure below, lamp 4 will be turned on as long as input X1 is active (energizing C13).

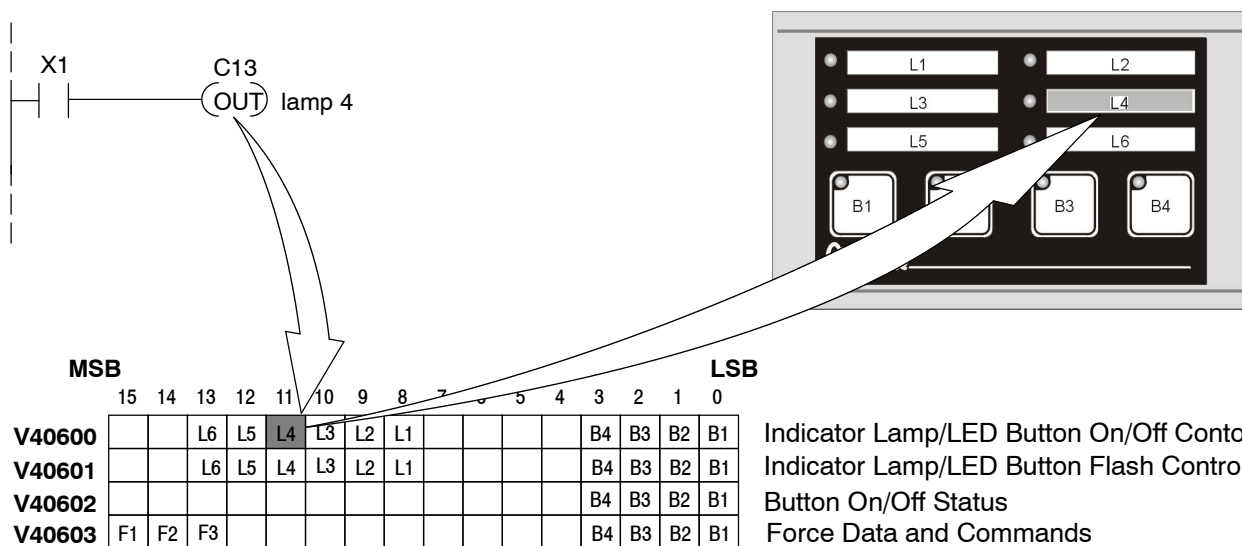

**Flashing a Lamp**

To cause a lamp to flash, you must turn the lamp on and set the associated flash bit. The example below shows a PLC program used to flash lamp 2 as long as X5 is energized.

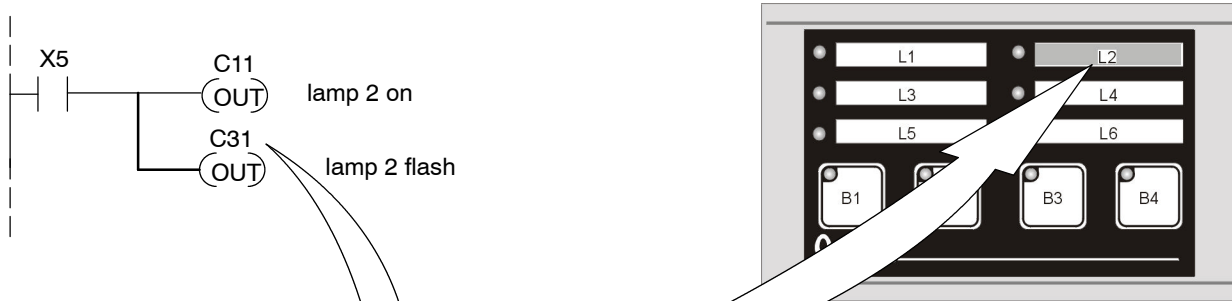

	MSB															LSB					
	15	14	13	12	11	10	9	8	7	6	5	4	3	2	1	0	B4	B3	B2	B1	
V40600				L6	L5	L4	L3	L2	L1								B4	B3	B2	B1	Indicator Lamp/LED Button On/Off Control
V40601				L6	L5	L4	L3	L2	L1								B4	B3	B2	B1	Indicator Lamp/LED Button Flash Control
V40602																	B4	B3	B2	B1	Button On/Off Status
V40603	F1	F2	F3														B4	B3	B2	B1	Force Data and Commands

**Using a Button**

The following example illustrates the use of an OP-406 button in a program. When button 3 is activated, C42 will become active and energize output Y0.



	MSB															LSB					
	15	14	13	12	11	10	9	8	7	6	5	4	3	2	1	0	B4	B3	B2	B1	
V40600				L6	L5	L4	L3	L2	L1								B4	B3	B2	B1	Indicator Lamp/LED Button On/Off Control
V40601				L6	L5	L4	L3	L2	L1								B4	B3	B2	B1	Indicator Lamp/LED Button Flash Control
V40602																	B4	B3	B2	B1	Button On/Off Status
V40603	F1	F2	F3														B4	B3	B2	B1	Force Data and Commands

**Lighting an Inset LED**

In LED Separation mode, the LEDs in the corner of each momentary pushbutton may be directly controlled by the PLC program. The example on the right shows a segment of a program that lights button 2's inset LED when input X7 is energized. *In order for this example to work, the panel must be configured for LED separation and button 2 must be a momentary pushbutton.*

	15	14	13	12	11	10	9	8	7	6	5	4	3	2	1	0	
V40600			L6	L5	L4	L3	L2	L1					B4	B3	B2	B1	Indicator Lamp/LED Button On/Off Control
V40601			L6	L5	L4	L3	L2	L1					B4	B3	B2	B1	Indicator Lamp/LED Button Flash Control
V40602													B4	B3	B2	B1	Button On/Off Status
V40603	F1	F2	F3										B4	B3	B2	B1	Force Data and Commands

**Flashing an Inset LED**

To flash an inset LED, you must turn it on and set the associated flash bit. The example below shows a program used to set the LED inset of button 1 to flash whenever X2 is energized. The table below it shows LED operation with button 1 set as alternate action.

	15	14	13	12	11	10	9	8	7	6	5	4	3	2	1	0		
V40600			L6	L5	L4	L3	L2	L1						B4	B3	B2	B1	Indicator Lamp/LED Button On/Off Control
V40601			L6	L5	L4	L3	L2	L1						B4	B3	B2	B1	Indicator Lamp/LED Button Flash Control
V40602														B4	B3	B2	B1	Button On/Off Status
V40603	F1	F2	F3											B4	B3	B2	B1	Force Data and Commands

Button State	X2 Status	LED Operation
Inactive	de-energized	Off
Inactive	energized	Off
Active	de-energized	On solid
Active	energized	Flashing

## Forcing Button Status

The OP-406 allows you to force the state of a button from the PLC.



**NOTE:** The Force Option must be selected (in OP-WINEDIT) in order to force setpoints and ONLY applies to Alternate Action Buttons.

### Force Button Status

This function is used to set the state (on or off) of every alternate action pushbutton. To use the “Force Button Status” function, set the F1 bit and all buttons that you want to be on, leaving all other bits off. The example below shows buttons 1 and 4 being forced on and buttons 2 and 3 being forced off when C377 is active

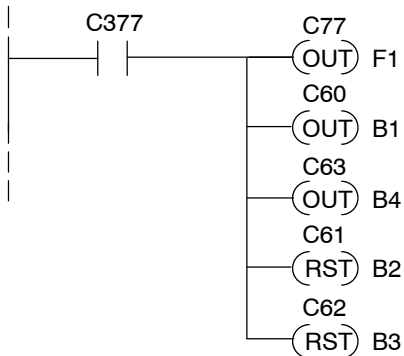

Set the F1 bit and the bits for Buttons 1 and 4. Clear Buttons 2 and 3.

**Force Button(s) On** This function is used to turn individual buttons on without affecting the state of any other buttons. To use the “Force Buttons On” function, set the F2 and all buttons that you want to turn on. Any buttons associated with bits that are not set will be unaffected. The following example shows buttons 2 and 3 being forced on when C377 is active.

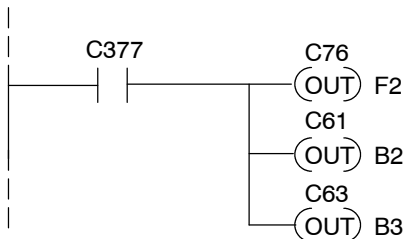

Set the F2 bit and the bits for Buttons 2 and 3. Buttons 1 and 4 are unaffected.

**Force Button(s) Off** This function is used to turn individual buttons off without affecting the state of any other buttons. To use the “Force Buttons Off” function, set the F3 and all buttons that you want to turn on. Any buttons associated with bits that are not set will be unaffected. The following example shows buttons 2 and 4 being cleared when C377 is active.

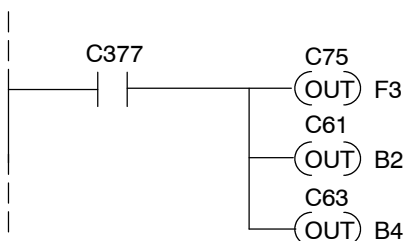

Set the F3 bit and the bits for Buttons 2 and 4. Buttons 1 and 3 are unaffected.

# Example Using D3-340

**Register Usage**

The following example assumes that the OP-406 is configured for a base address of R20.

*DirectSOFT*

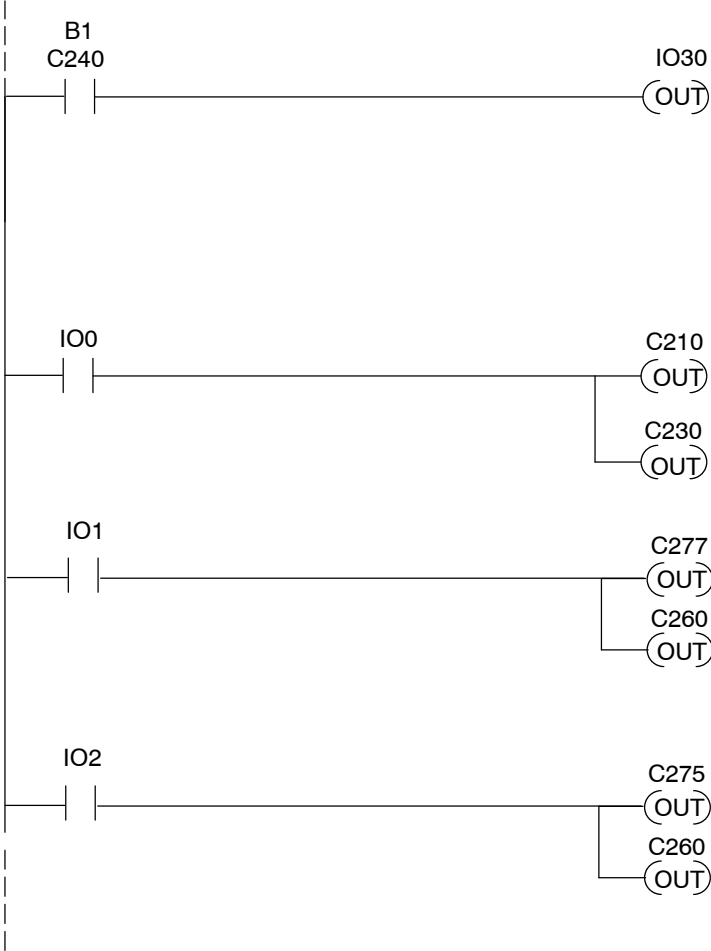

The base address starts at R20 (C200), so B1-B4 is assigned to C240-C243.

L1-L6 are assigned to C210-C215. IO0 turns Lamp 1 on. Turning C230 on makes L1 flash.

This rung uses the Force Function to force Button 1 ON. IO30 energizes when Button 1 is forced ON (see rung 1). R26 is the Force Register.

This rung clears Forced Button 1.

# Examples Using Allen-Bradley™ SLC 5/03, 5/04 and Micrologix PLCs

## Interfacing to A-B Memory

OptiMate panels interface to Allen-Bradley SLC 5/03, SLC 5/04 and Micrologix PLCs via integer file type N. The 5/03 and 5/04 have file type N7 as standard. Other "N" type files can be created. The Micrologix has a fixed file type N7. Please see A-B documentation for information on setting up and using "N" type files.



**NOTE:** When using an OP-406 with an Allen-Bradley PLC, always be sure that at least 4 words of memory are allocated to allow proper communications.

## Turning on a Lamp

Turning on a lamp requires activating the associated control relay coil. In the figure below, lamp 4 will be turned on as long as input I:0.0/4 is active (energizing N7:0/11).

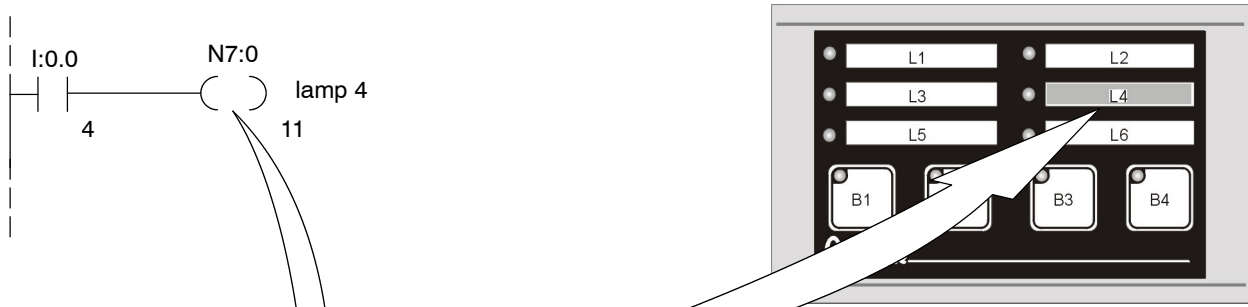

	MSB										LSB						
	15	14	13	12	11	10	9	8	7	6	5	4	3	2	1	0	
N7:0			L6	L5	L4	L3	L2	L1					B4	B3	B2	B1	Indicator Lamp/LED Button On/Off Control
N7:1			L6	L5	L4	L3	L2	L1					B4	B3	B2	B1	Indicator Lamp/LED Button Flash Control
N7:2													B4	B3	B2	B1	Button On/Off Status
N7:3	F1	F2	F3										B4	B3	B2	B1	Force Data and Commands



**Flashing a Lamp**

To cause a lamp to flash, you must turn the lamp on and set the associated flash bit. The example below shows a PLC program used to flash lamp 2 as long as I:0.0/5 is energized.

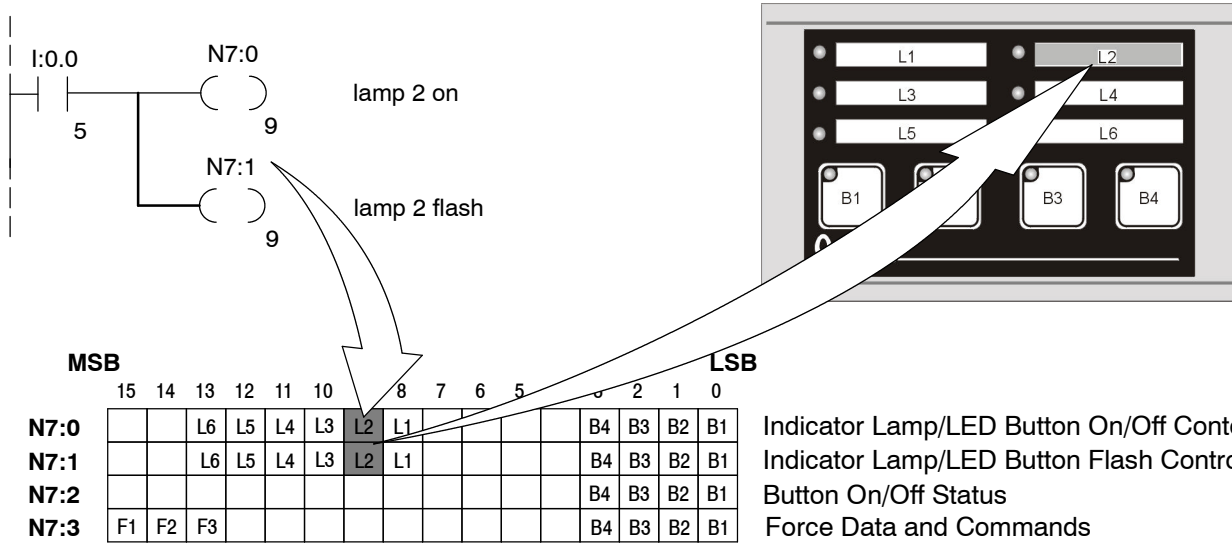

**Using a Button**

The following example illustrates the use of an OP-406 button in a program. When button 3 is activated, N7:2/2 will become active and energize output O:0.1/5.

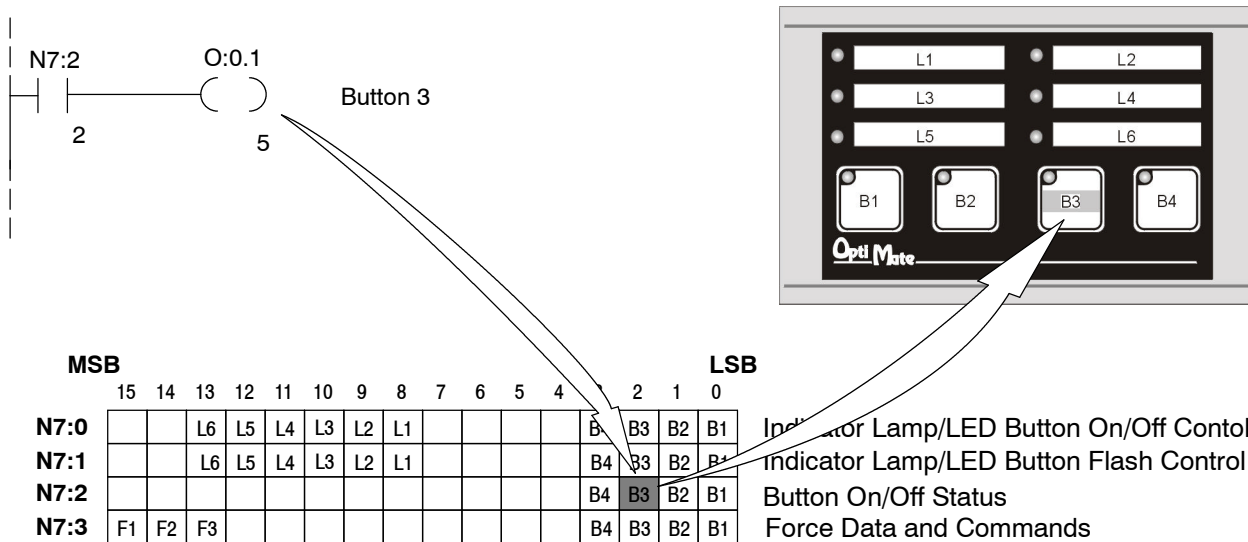

### Lighting an Inset LED

In LED Separation mode, the LEDs in the corner of each momentary pushbutton may be directly controlled by the PLC program. The example on the right shows a segment of a program that lights button 4's inset LED when input I:0.2/12 is energized. *In order for this example to work, the panel must be configured for LED separation and button 2 must be a momentary pushbutton.* You can flash the LED by turning on the appropriate flash bit. In the following example, when N7:0/3 is on, turn on N7:1/3 to flash.

	15	14	13	12	11	10	9	8	7	6	5	4	3	2	1	0	
N7:0			L6	L5	L4	L3	L2	L1					B4	B3	B2	B1	Indicator Lamp/LED Button On/Off Control
N7:1			L6	L5	L4	L3	L2	L1					B4	B3	B2	B1	Indicator Lamp/LED Button Flash Control
N7:2													B4	B3	B2	B1	Button On/Off Status
N7:3	F1	F2	F3										B4	B3	B2	B1	Force Data and Commands

### Flashing an Inset LED

To flash an inset LED, you must turn it on and set the associated flash bit. The example below shows a program used to set the LED inset of button 1 to flash whenever I:0.3/4 is energized. The table below it shows LED operation with button 1 set as alternate action.

	15	14	13	12	11	10	9	8	7	6	5	4	3	2	1	0	
N7:0			L6	L5	L4	L3	L2	L1					B4	B3	B2	B1	Indicator Lamp/LED Button On/Off Control
N7:1			L6	L5	L4	L3	L2	L1					B4	B3	B2	B1	Indicator Lamp/LED Button Flash Control
N7:2													B4	B3	B2	B1	Button On/Off Status
N7:3	F1	F2	F3										B4	B3	B2	B1	Force Data and Commands

Button State	X2 Status	LED Operation
Inactive	de-energized	Off
Inactive	energized	Off
Active	de-energized	On solid
Active	energized	Flashing

**NOTE:** When using an OP-406 with an Allen-Bradley PLC, always be sure that at least 4 words of memory are allocated to allow proper communications.



# Forcing Button Status



**NOTE:** The Force Option must be selected (in OP-WINEDIT) in order to force setpoints and ONLY applies to Alternate Action Buttons.

## Force Button Status

This function is used to set the state (on or off) of every alternate action pushbutton. To use the "Force Button Status" function, set the F1 bit and all buttons that you want to be on, leaving all other bits off. The example below shows buttons 1 and 3 being forced on and all other buttons forced off when B3:4/2 is active

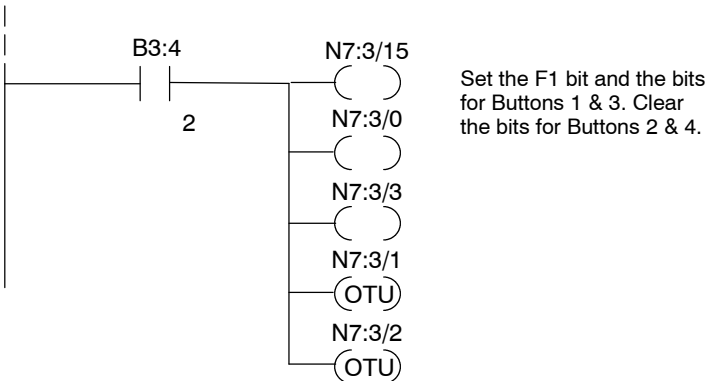

## Force Button(s) On

This function is used to turn individual buttons on without affecting the state of any other buttons. To use the "Force Buttons On" function, set the F2 and all buttons that you want to turn on. Any buttons associated with bits that are not set will be unaffected. The following example shows buttons 2 and 4 being forced on when B3:4/2 is active.

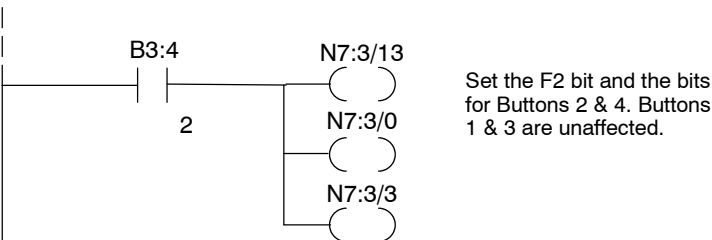

## Force Button(s) Off

This function is used to turn individual buttons off without affecting the state of any other buttons. To use the "Force Buttons Off" function, set the F3 and all buttons that you want to turn on. Any buttons associated with bits that are not set will be unaffected. The following example shows buttons 1 and 4 being cleared when B3:4/2 is active.

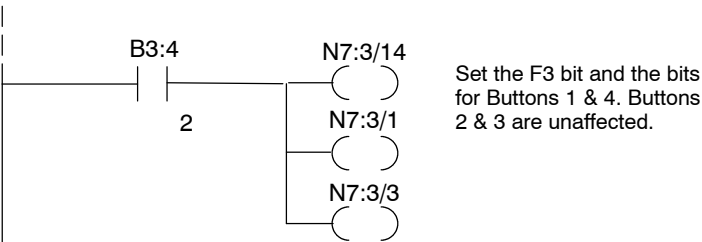

## Troubleshooting the OP-406 Panel

- Troubleshooting** In this section, we explain how to isolate potential problems which may occur while using the OP-406. Because these panels have only a power supply connection and a communications connection, (no DIP switches or controls to set, and cannot be used in multiple panel arrangements), troubleshooting is very straightforward.
- Power Supply Problems** If the panel LED display, the Button indicators, and the RX and TX LEDs on the back of the panel do not illuminate, the panel is most likely not receiving input power. Carefully check your connections to make sure they are tight. If this does not help, see Chapter 2 and review the input power requirements.
- Remember, all PLC's require that you use the OP-PS400 5V plug-in power supply (or equivalent) for configuration. Some PLC's also require that you use this power supply for operation. Make sure that the 120 VAC receptacle you plug the power supply into has power. Also, if you are using another 5V power supply, make sure that it has a center negative connector.
- If using a PLC that supplies 5V for operation through the communications cable, check to make sure sure that pin 5 on the lead going into the panel has a 5V signal.
- Configuration Problems** Make sure that you are using the proper configuration cable (OP-CCBL) and that it is securely connected. Check your configuration program and make sure the proper communications port is selected, such as COM1 or COM2. Review your configuration settings to make sure they are correct. Remember, the OP-WINEDIT Help screens provide a lot of valuable information.
- Communication Problems** Observe the RX and TX LEDs on the rear panel. They should be steady flashing or glow (depending on the baud rate). If not, make sure that you are using the proper communications cable and that it is securely connected. Review your configuration settings and make sure that the communications information for your PLC, address number, baud rate, protocol type, etc. is correct. Check the user manual for your PLC for the proper settings.
- Getting Help** See "Technical Support" in Chapter 1 for additional information.