

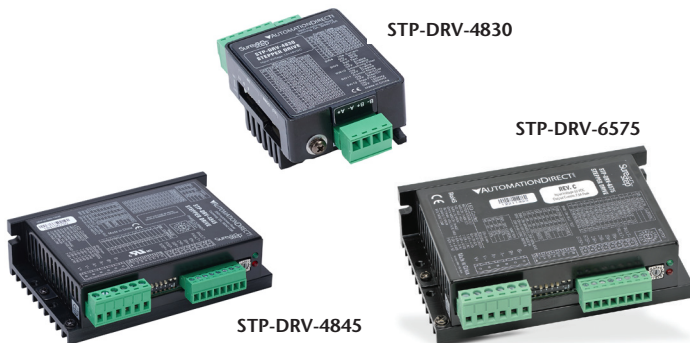

# 2

## In This Chapter...

Features . . . . .	2-2
Specifications . . . . .	2-3
Typical Wiring Diagram . . . . .	2-5
Wiring Connections and Configuration Switches . . . . .	2-5
STP-DRV-4830 . . . . .	2-5
STP-DRV-4845 and STP-DRV-6575 . . . . .	2-6
Connecting the Motor . . . . .	2-7
Connecting the Power Supply . . . . .	2-8
SureStep™ Drive Digital Inputs and Outputs . . . . .	2-9
Connecting the Input Signals: STEP and DIR . . . . .	2-9
Connecting the Input Signals – EN Input . . . . .	2-10
Connecting the Fault Output . . . . .	2-11
Drive Configuration . . . . .	2-12
Drive Configurations Settings . . . . .	2-12
DIP Switch Settings . . . . .	2-13
Alarm Codes . . . . .	2-16
Mounting the Drive . . . . .	2-19
Drive Heating . . . . .	2-19
Dimensions and Mounting Slot Locations . . . . .	2-19
STP-DRV-4830 . . . . .	2-19
STP-DRV-4845 and STP-DRV-6575 . . . . .	2-20



## Features

- Low cost, digital step motor driver in compact package
- Operates from Step & Direction signals, or Step CW & Step CCW. CW and CCW rotation are viewed from the end opposite the drive end of the motor (looking out of the shaft)
- Enable input & Fault output (STP-DRV-4830 does not have a fault output)
- Optically isolated I/O
- Digital filters prevent position error from electrical noise on command signals; selectable: 150 kHz or 2MHz (-4845 and -6575 models), 150kHz or 500kHz (-4830 model)
- Rotary switch for selecting several SureStep motors or phase current settings
- Electronic damping and anti-resonance (-4845 and -6575 only)
- Automatic idle current reduction to reduce heat when motor is not moving; switch selectable: 50% or 90% of running current
- Switch-selectable step resolution: 200 (full-step); 400 (half-step); up to 20,000 (for -4845 and -6575) or up to 25600 (for the -4830) steps per revolution
- Switch selectable step input signal smoothing (microstep emulation) provides smoother, more reliable motion in full and half-step modes for the -4845 and -6575, and all step resolutions for the -4830
- Automatic self test (switch selectable)
- Drives operate from 12 or 24 to 48 or 72 VDC power supplies
- Running current ranges from 0.35 to 7.5A depending on drive

## Specifications

SureStep™ Microstepping Drive Specifications				
Part Number	STP-DRV-4830		STP-DRV-4845	STP-DRV-6575
Input Power	12–48 VDC (53VDC max) (external power supply required; fuse at 3A fast-acting)		24–48 VDC (60VDC max) (external power supply required; fuse at 4A fast-acting)	24–75 VDC (85VDC max) (external power supply required; fuse at 7A fast-acting)
Output Current	0.35–3.0 A/phase (peak of sine)		0.8–4.5 A/phase (peak of sine)	1.0–7.5 A/phase (peak of sine)
Current Controller	Dual H-bridge digital MOSFET, 4-quadrant PWM at 16kHz		Dual H-bridge digital MOSFET, 4-quadrant PWM at 20kHz	
Input Signals	Step Function	Step or Step CW pulse		
	Step Electrical Specs	5 –24 VDC nominal (range: 4–30 VDC); (5mA @ 4V; 15 mA @ 30V); Optically isolated, differential.		
		Maximum pulse frequency = 150 kHz or 500 kHz (user selectable). Minimum pulse width: 3 usec at 150 kHz setting SW12, 1 usec at 500 kHz setting SW12	Maximum pulse frequency = 150 kHz or 2MHz (user selectable). Minimum pulse width: 3 usec at 150 kHz setting jumper 4 1 usec at 2 MHz setting jumper 4	
	DIR Function	Direction or Step CCW pulse		
	DIR Electrical Specs	5 –24 VDC nominal (range: 4–30 VDC); (5mA @ 4V; 15 mA @ 30V); Optically isolated, differential.		
		Max pulse frequency: 500 kHz Minimum pulse width: 3 usec at 150 kHz setting SW12, 1 usec at 500 kHz setting SW12	Maximum pulse frequency = 150 kHz or 2MHz (user selectable). Minimum pulse width: 3 usec at 150 kHz setting jumper 4 1 usec at 2 MHz setting jumper 4	
	EN Function	Disable motor when closed		
EN Electrical Specs	5 –24 VDC nominal (range: 4–30 VDC); (5mA @ 4V; 15 mA @ 30V); Optically isolated, differential. Max pulse frequency: 10 kHz Minimum pulse width: 500 usec			
Output Signal	Fault	n/a	30 VDC / 80mA max, optically isolated photodarlington, sinking or sourcing. Function = closes on drive fault.	
Rotary Switch Selectable Function		n/a	Select motor based on part number, or by motor current.	

## Specifications, continued

SureStep™ Microstepping Drive Specifications				
Part Number	STP-DRV-4830	STP-DRV-4845	STP-DRV-6575	
Jumper and DIP Switch Selectable Functions	Step Pulse Type	Step and Direction: Step signal = step/pulse; Direction signal = direction. Step CW & CCW: Step signal = CW step; Direction signal = CCW step (Internal jumper for -4845 and -6575; DIP switch for -4830)		
	Step Pulse Noise Filter	150kHz or 500kHz (switch to 500kHz if pulsing faster than 150kHz (DIP switch))	150 kHz or 2MHz (switch to 2MHz if pulsing faster than 150kHz)(internal jumper)	
	Current Reduction (DIP switch)	n/a	Reduce power consumption and heat generation by limiting motor running current to 100%, 90%, or 80%, (70% possible for STP-DRV-4845 only and 120% possible for the -6575 only) of maximum. Current should be increased to the maximum current reduction setting if microstepping. (Torque is reduced/increased by the same %.)	
	Idle Current Reduction (DIP switch)	Reduce power consumption and heat generation by limiting motor idle current to 90% or 50% of running current. (Holding torque is reduced by the same %.)		
	Load Inertia (DIP switch)	n/a	Anti-resonance and damping feature improves motor performance. Set motor and load inertia range to 0–4x or 5–10x.	
	Step Resolution (DIP switch)	200, 400, 800, 1000, 1600, 2000, 3200, 4000, 5000, 6000, 6400, 8000, 10000, 12800, 20000, 25600.	200, 200 smooth, 400, 400 smooth, 2000, 5000, 12800, 20000	
	Self Test (DIP switch)	Automatically rotate the motor back and forth two turns in each direction in order to confirm that the motor is operational.		
	Smoothing Filter (DIP switch)	Softens the effect of immediate changes in velocity and direction, making the motion of the motor less jerky. Can cause a small delay in following the control signal.		n/a
Drive Cooling Method	Natural convection (mount drive to metal surface)			
Mounting	Use (2) #6 screws to mount to metal surface			
Removable Connectors	DEGSON 15EDGK-5.08-02P-14-00AH 2-pin power connector DEGSON 15EDGK-3.1.04P-14-00A(H) 4-pin motor connector DEGSON 15EDGK-3.5-06P-14-00A(H) 6-pin I/O connector Part number STP-CON-5 contains replacements		Motor & Power Supply: Screw terminal blocks Phoenix Contact 1757051 (30–12AWG) Signals: Screw terminal blocks Phoenix Contact 1803633 (30–14 AWG) AutomationDirect part number STP-CON-1 contains these replacement connectors.	
Weight	3.0 oz [85.9g]		10.8 oz [306g]	
Operating Temperature	0 to 85 °C [32 to 185 °F] – (Interior of electronics section)			
Ambient Temperature	0 to 40 °C [32 to 104 °F]			
Humidity	Maximum 90% non-condensing			
Agency Approvals	CE		CE c_UR <sub>US</sub>	

## Typical Wiring Diagram

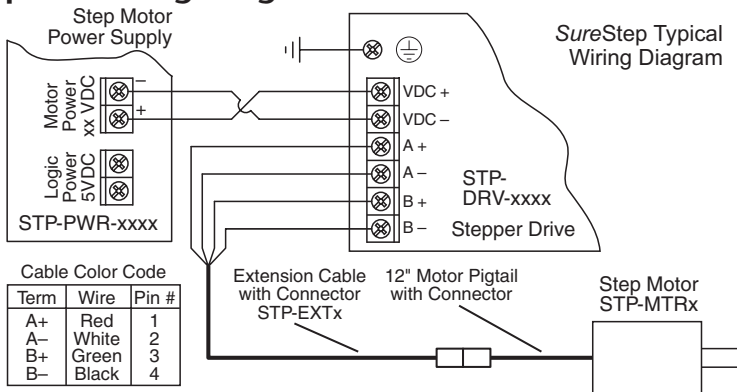

## Wiring Connections and Configuration Switches

### STP-DRV-4830

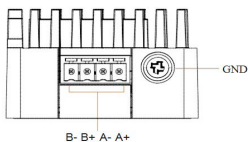
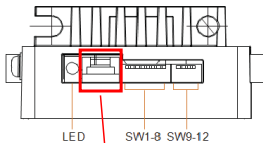
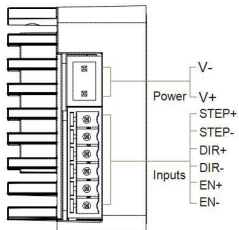

Terminal block part #s (shown) are Phoenix Contact ([www.phoenixcontact.com](http://www.phoenixcontact.com)) All three terminal blocks are included in STP-CON-5 for replacement connectors

External wiring is connected using three separate pluggable screw terminal connectors. The power connections are on the 2-position connector, the motor connection is on the 4-position connector, and the digital inputs are on the 6-position connector.

## STP-DRV-4845 and STP-DRV-6575

### Terminals, Switches, Indicators

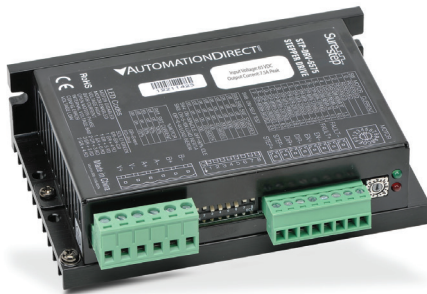
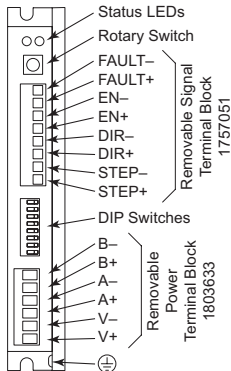

Terminal block part #s (shown) are  
 Phoenix Contact ([www.phoenixcontact.com](http://www.phoenixcontact.com))  
 Both terminal blocks are included in STP-CON-1  
 for replacement connectors

External wiring is connected using two separate pluggable screw terminal connectors. The power connections share a six-position connector, and the digital inputs and output share an eight-position connector.

## Connecting the Motor



**Warning:** When connecting a step motor to a SureStep™ microstepping drive, be sure that the motor power supply is switched off. When using a motor not supplied by AutomationDirect, secure any unused motor leads so that they can't short out to anything. Never disconnect the motor while the drive is powered up. Never connect motor leads to ground or to a power supply. (See the Typical Wiring Diagram shown in this chapter for the step motor lead color code of AutomationDirect supplied motors.)



*CW and CCW are viewed from the end opposite the drive end of the motor (looking out of the shaft).*

### Four Lead Motors

Four lead motors can only be connected one way, as shown below.

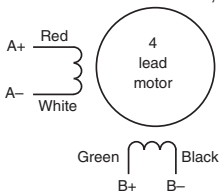

#### 4 Leads



*All AutomationDirect SureStep™ motors are four lead bipolar step motors except STP-MTRAC-x motors.*

### Six Lead Motors

Six lead motors can be connected in series or center tap. Motors produce more torque at low speeds in series configuration, but cannot run as fast as in the center tap configuration. In series operation, the motor should be operated at 30% less than rated current to prevent overheating.

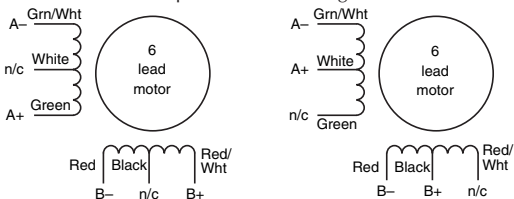

#### 6 Leads Series Connected

#### 6 Leads Center Tap Connected



*Step motor wire lead colors vary from one manufacturer to another.*

### Eight Lead Motors

Eight lead motors can also be connected in two ways: series or parallel. Series operation gives you more torque at low speeds, but less torque at high speeds. When using series connection, the motor should be operated at 30% less than the rated current to prevent over heating. Parallel operation allows greater torque at high speeds. When using parallel connection, the current can be increased by 40% above rated current. Care should be taken in either case to assure that the motor does not overheat.

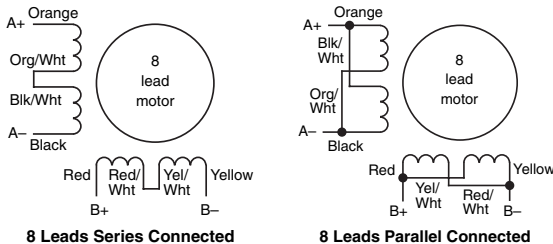

8 Leads Series Connected

8 Leads Parallel Connected



Step motor wire lead colors vary from one manufacturer to another. The example above only pertains to STP-MTRAC-34075(x) and 34115(x) SureStep Motors. For NEMA 42 wire colors, see “Connecting a STP-MTRAC(H)-42 Motor” in Chapter 7.

## Connecting the Power Supply

An STP-PWR-xxxx power supply from AutomationDirect is the best choice to power the step motor drive. If you need information about choosing a different power supply, refer to the section entitled “Choosing a Power Supply” in Chapter 7 of this manual.

If your power supply does not have a fuse on the output or some kind of short circuit current limiting feature, you need a fuse between the drive and the power supply. Install the fuse on the + power supply lead.

- Connect the green ground screw to earth ground
- Use 18 or 20 AWG wire.

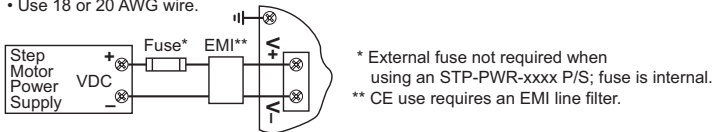

Further information about EMI line filters, braking accessories, and regeneration clamping can be found in Appendix A: “SureStep Accessories” and the STP-DRVA-RC-050A or STP-DRVA-RC-050 REGENERATION CLAMP datasheet.



**Do NOT use STP-PWR-70xx power supplies with an STP-DRV-6575 drive, because those power supplies can exceed the voltage limit of this drive if supplied with a higher than normal 120VAC supply. STP-DRV-6575 overvoltage fault is 85V.**



## Connecting the I/O

### SureStep™ Drive Digital Inputs and Outputs

The SureStep STP-DRV-4830, -4845, and -6575 drives include two high-speed 5–24 VDC digital inputs (STEP & DIR), one standard-speed 5–24 VDC digital input (EN), and one 30 VDC digital output (Fault). The -4830 does not have an output.

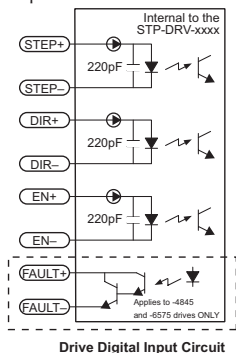

The digital inputs are optically isolated to reduce electrical noise problems. There is no electrical connection between the control and power circuits within the drive, and input signal communication between the two circuits is achieved by infrared light. Externally, the drive's motor power and control circuits should be supplied from separate sources, such as from a step motor power supply with separate power and logic outputs.

For bidirectional rotation, supply a source of step pulses to the drive at the STEP+ and STEP– terminals, and a directional signal at the DIR+ and DIR– terminals.

The ENABLE input allows the logic to turn off the current to the step motor by providing a signal to the EN+ and EN– terminals. The EN+ and EN– terminal can be left unconnected if the enable function is not required.

All logic inputs can be controlled by a DC output signal that is either sinking (NPN), sourcing (PNP), or differential.

### Connecting the Input Signals: STEP and DIR

#### Connecting Inputs to an Indexer with Sinking Outputs

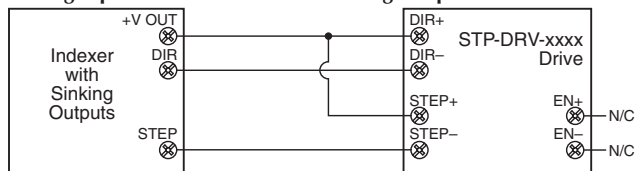

#### Connecting Inputs to an Indexer with Sourcing Outputs

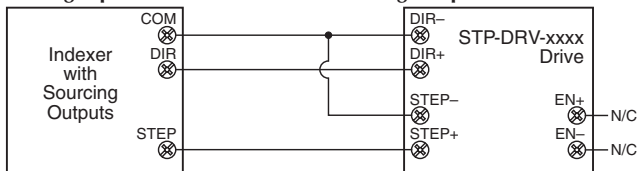

## Connecting the Input Signals – STEP and DIR (continued)

### Connecting Inputs to an Indexer with Differential Line Driver Outputs

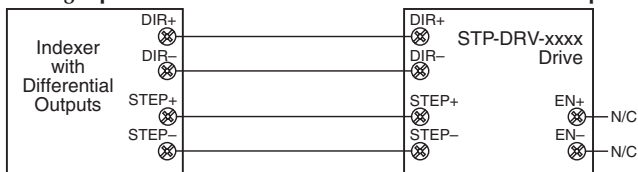

## Connecting the Input Signals – EN Input

The ENABLE input allows the user to turn off the current to the motor by providing a 5–24 VDC positive voltage between EN+ and EN-. The logic circuitry continues to operate, so the drive “remembers” the step position even when the amplifiers are disabled. However, the motor may move slightly when the current is removed depending on the exact motor and load characteristics.



**Warning:** 24VDC is the maximum voltage that can be applied directly to the standard speed EN input. If using a higher voltage power source, install resistors to reduce the voltage at the input. Do NOT apply an AC voltage to an input terminal.

### Connecting ENABLE Input to Relay or Switch

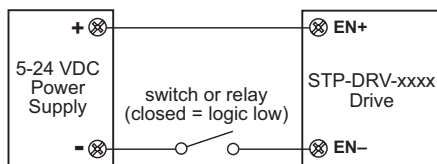

### Connecting ENABLE Input to NPN Proximity Sensor

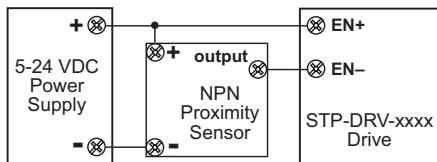

### Connecting ENABLE Input to PNP Proximity Sensor

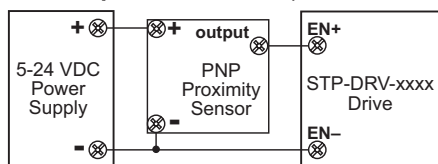

*Leave the ENABLE input unconnected if you do not need to disable the amplifiers.*

### Connecting the Fault Output

The SureStep STP-DRV-4845 and -6575 drives have one digital output that has separate positive (+) and negative (-) terminals, and can be used to sink or source current. There is no digital output on the STP-DRV-4830.

#### Connecting FAULT Output to Inductive Relay

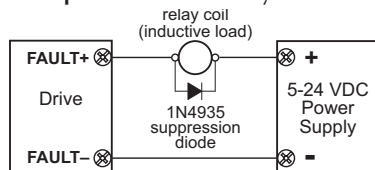

#### Connecting FAULT Output as Sinking Output

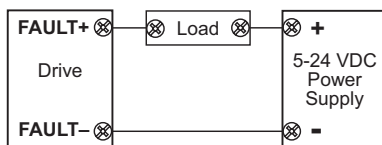

#### Connecting FAULT Output as Sourcing Output

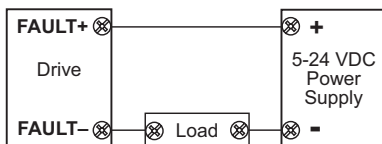

*Do not connect more than 30 VDC. Current must not exceed 80 mA.*

## Drive Configuration

You need to configure your drive for your particular application before using the drive for the first time. The SureStep STP-DRV-4830, -4845, and -6575 microstepping drives offer several features and configuration settings, including:

### Drive Configurations Settings

Drive Configuration Settings				
Feature	Description	Configuration Method		
		STP-DRV-4830	STP-DRV-4845	STP-DRV-6575
<b>Motor Phase Current</b>	Select motor based on part number, or set by motor current.	Set current via DIP switch 1,2,3	Set current via rotary switch	Select motor via rotary switch
<b>Mode of Operation (Step Pulse Type)</b>	Step and Direction (default): Step signal = step/pulse; Direction signal = direction. Step CW & CCW: Step signal = CW step; Direction signal = CCW step.	DIP switch 11	Jumper S3 (see details later in this section)	
<b>Step Pulse Noise Filter</b>	Select 150 kHz or 2MHz for -4845 and -6575 or Select 150 kHz or 500 kHz for -4830	DIP switch 12	Jumper S4 (see details later in this section)	
<b>Current Reduction</b>	Reduce power consumption and heat generation by limiting motor running current to 100%, 90%, or 80% of maximum. Current should be increased to 120% if microstepping. (Torque is reduced/increased by the same %.)	N/A	DIP switch 1,2	
<b>Idle Current Reduction</b>	Reduce power consumption and heat generation by limiting motor idle current to 90% or 50% of running current. (Holding torque is reduced by the same %.)	DIP switch 4		
<b>Load Inertia</b>	Anti-resonance and damping feature improve motor performance. Set motor and load inertia range to 0–4x or 5–10x.	N/A	DIP switch 3	
<b>Step Resolution</b>	For smoother motion and more precise speed, set the pulse per revolution value as needed.	DIP switch 5,6,7,8	DIP switch 5,6,7	
<b>Self Test</b>	Automatically rotates the motor back and forth 1/2 a revolution in each direction in order to confirm that the motor is operational.	DIP switch 9	DIP switch 8	
<b>Step Smoothing Filter</b>	Softens the effect of immediate changes in velocity and direction, making the motion of the motor less jerky. Can cause a small delay in following the control signal.	DIP switch 10	N/A (step smoothing is available using the “200 smooth” or “400 smooth” setting for DIP switch 5,6,7)	

## DIP Switch Settings

### STP-DRV-4830

(Factory default = switches 1-4 ON, switches 5-12 OFF)

#### Current Setting

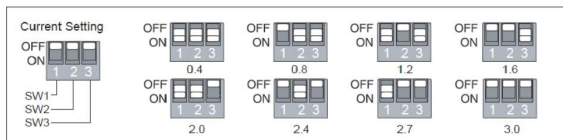

#### Step Resolution (steps/rev)

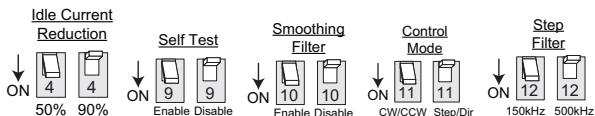
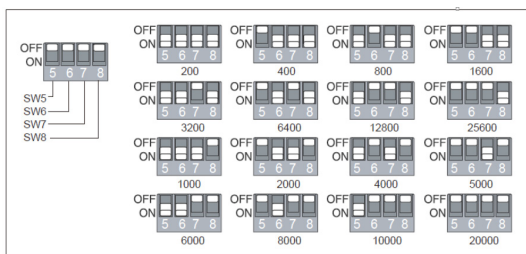

### STP-DRV-4845 and STP-DRV-6575

(Factory default = all switches OFF)

#### Step Resolution (steps/rev)

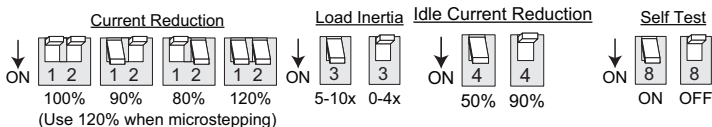
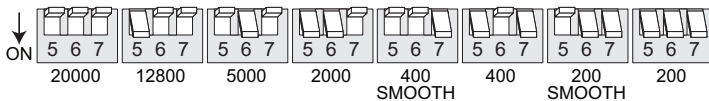

### Jumper Settings for STP-DRV-4845 and STP-DRV-6575

Jumpers S3 and S4 are located on the internal circuit board, and they can be accessed by removing the drive's front cover.

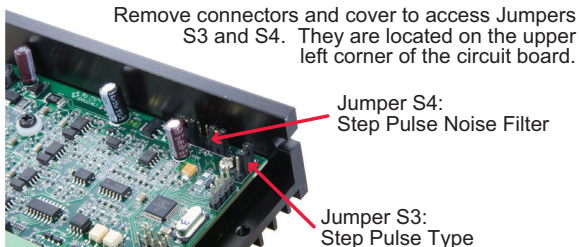

#### Jumper S3 – Step Pulse Type

- Jumper in “1-2” position – Step & Direction (factory default)
- Jumper in “1-3” position – Step CW / Step CCW

#### Jumper S4 – Step Pulse Noise Filter

- Jumper in “1-2” position – 2MHz (factory default)
- Jumper in “1-3” position – 150 kHz

### Rotary Switch Settings – Motor/Current Settings



















<i>STP-DRV-4845 Motor Selection Table</i>					
<i>(A/Phase)(Peak of Sine A)</i>					
<i>Rotary Switch Position</i>	<i>SW1 &amp; SW2 @100%</i>	<i>SW1 &amp; SW2 @90%</i>	<i>SW1 &amp; SW2 @80%</i>	<i>SW1 &amp; SW2 @70%</i>	
<b>0</b>	1.1	1.0	0.9	0.8	
<b>1</b>	1.3	1.2	1.0	0.9	
<b>2</b>	1.5	1.4	1.2	1.1	
<b>3</b>	1.7	1.5	1.4	1.2	
<b>4</b>	2.0	1.8	1.6	1.4	
<b>5</b>	2.2	2.0	1.8	1.5	
<b>6</b>	2.4	2.2	1.9	1.7	
<b>7</b>	2.6	2.3	2.1	1.8	
<b>8</b>	2.8	2.5	2.2	2.0	
<b>9</b>	3.1	2.8	2.5	2.2	
<b>A</b>	3.4	3.1	2.7	2.4	
<b>B</b>	3.6	3.2	2.9	2.5	
<b>C</b>	3.8	3.4	3.0	2.7	
<b>D</b>	4.0	3.6	3.2	2.8	
<b>E</b>	4.3	3.9	3.4	3.0	
<b>F</b>	4.5	4.1	3.6	3.2	

STP-DRV-6575 Motor Selection Table										
Motor STP-MTR -xxx(X)	Motor Data					Drive Configuration Data			Rotary Switch Position	
	Motor Current (A <sub>rms</sub> /phase)	Holding Torque (oz-in)	Rotor Inertia (oz-in <sup>2</sup> )	Inductance (mH)	Resistance (Ω)	Torque (mN-m)	Inertia (g-cm <sup>2</sup> )	Drive Current (peak sine A)		
n/a	reserved								0-2	
n/a	1.3	custom NEMA 17								3
n/a	4.0	custom NEMA 23								4
n/a	4.0	custom NEMA 34								5
-17040	1.7	61	0.28	3.03	1.60	434	51	2.04	6	
-17048	2.0	83	0.37	2.65	1.40	586	82	2.40	7	
-17060	2.0	125	0.56	3.30	2.00	883	37	2.40	8	
-23055	2.8	166	1.46	2.36	0.08	1172	271	3.36	9	
-23079	2.8	276	2.60	3.82	1.10	1949	475	3.36	A	
-34066	2.8	434	7.66	7.70	1.11	3065	1402	3.36	B	
H-23079	5.6	287	2.60	1.18	0.40	2025	371	6.72	C	
H-34066	6.3	428	7.66	1.52	0.25	3021	1402	7.56	D	
H-34097	6.3	803	14.80	2.07	0.03	5668	2708	7.56	E	
H-34127	6.3	1292	21.90	4.14	0.49	9123	4008	7.56	F	



## Alarm Codes

In the event of a drive fault or alarm, the green LED will flash one or two times, followed by a series of red flashes. The pattern repeats until the alarm is cleared.

STP-DRV-xxxx Alarm Codes		
Alarm Code	LED Sequence	Alarm Description
SG	 Solid green	No alarm, motor disabled
FG	 Fast green	Factory use
01	 Flashing green	No alarm, motor enabled
10	 Flashing red	Configuration or memory error <sup>1</sup>
11	 1 red, 1 green	Motor stall (optional encoder only) <sup>4</sup>
12	 1 red, 2 green	Move attempted while drive disabled
21	 2 red, 1 green	CCW limit
22	 2 red, 2 green	CW limit
31	 3 red, 1 green	Drive overheating
32	 3 red, 2 green	Internal voltage out of range <sup>2</sup>
33	 3 red, 3 green	Factory use
41	 4 red, 1 green	Power supply overvoltage <sup>2</sup>
42	 4 red, 2 green	Power supply undervoltage
43	 4 red, 3 green	Flash memory backup error
51	 5 red, 1 green	Over current / short circuit <sup>2, 3</sup>
61	 6 red, 1 green	Open motor winding <sup>2</sup>
62	 6 red, 2 green	Bad encoder signal (optional encoder only) <sup>4</sup>
71	 7 red, 1 green	Serial communication error <sup>5</sup>
72	 7 red, 2 green	Flash memory error

1 - Does not disable the motor.  
The alarm will clear about 30 seconds after the fault is corrected.

2 - Disables the motor. Cannot be cleared until power is cycled.

3 - The over-current/short-circuit alarm typically indicates that an electrical fault exists somewhere in the system external to the drive. This alarm does not serve as motor overload protection.

4 - This alarm only occurs on STP-MTRD advanced integrated motor/drives

5 - This alarm only occurs on drives with serial communication.



## Alarm Code Definitions

Alarm Code	Error	Description	Corrective Action
SG	No alarm, motor disabled	No faults active, Circuit is closed between EN+ and EN-.	N/A
01	No alarm, motor enabled	No faults active, Circuit is open between EN+ and EN-.	N/A
10	Configuration or memory error	Memory error detected when trying to load config from flash on powerup.	Restart device. No fix if restart doesn't work. Return to manufacturer for correction.
11	Motor stall (optional encoder only)	Motor torque demand exceeded capability and the motor skipped steps. This is configured in SureMotion Pro.	Increase torque utilization if it's not already maxed out, otherwise decrease the torque demand by modifying the move profile, or put in a larger motor.
12	Move attempted while drive disabled	Drive is disabled and move attempted.	Reset alarm, enable motor, and move again.
21	CCW limit	CCW limit is reached. The digital input that has been assigned CCW limit has been activated.	Unblock the CCW sensor (open the circuit) or redefine the input with SureMotion Pro.
22	CW limit	CW limit is reached. The digital input that has been assigned CW limit has been activated.	Unblock the CCW sensor (open the circuit) or redefine the input with SureMotion Pro.
31	Drive overheating	The drive's internal temperature is too high.	If the drive is operating within its standard range (input voltage and output current are OK), more heat must be removed from the drive during operation. For Advanced drives (see "Mounting the Drive" on page 4-14), ensure the drive is mounted to a metal surface that can dissipate the drive's heat. For Integrated motor/drives, see "Mounting" on page 5-13. For both types of drives: If the mounting surface cannot pull enough heat away from the drive, forced airflow (from a fan) may be required to cool the drive.
32	Internal voltage out of range	Gate voltage, 5V rail, or 3V rail are out of spec.	Ensure adequate supply voltage (in very rare cases, low input voltages combined with fast accelerations can draw down the gate voltage) and try again. If persistent, RMA is required.

Alarm Code	Error	Description	Corrective Action
41	Power supply overvoltage	The DC voltage feeding the drive is above the allowable level.	Decrease the input voltage. Linear power supplies do not output a fixed voltage: the lighter the output current, the higher the output voltage will float. If a linear supply's voltage floats above the drive's max voltage, you can install a small power resistor across the linear power supply's output to provide some load that will help pull down the floating voltage. Consider using a switching power supply such as the Rhino PSB power supply series. Overvoltage can also be fed back into a system by regeneration (when an overhauling load pushes energy back into the motor). In an application with regen problems, install an STP-DRVA-RC-050 regen clamp to help dissipate the extra energy. (The regen clamp will not help with the floating linear power supply that floats too high, but it will help with excess voltage generated from an overhauling load.)
42	Power supply undervoltage	The DC voltage feeding the drive is below the allowable level.	Correct the power supply. If this error occurs during operation, the power supply is most likely undersized. A sudden high current demand can cause an undersized power supply to dip in output voltage.
43	Flash memory backup error	Memory error detected when trying to load config from flash on powerup.	Restart device. No fix if restart doesn't work. Return to manufacturer for correction.
51	Over current / short circuit	Motor leads shorted - only checked on powerup.	Check and fix motor wiring.
61	Open motor winding	Motor leads not connected - only checked on powerup.	Check and fix motor wiring.
62	Bad encoder signal (optional encoder only)	Noisy or otherwise incorrectly formatted encoder signal (lack of A or B, lack of differential signal).	Check encoder wiring, always use differential encoders (or use checkbox in SureMotion Pro to disable this error when using single ended).
71	Serial communication error	Catch-all error for something wrong with serial communications. See CE command in HCR for details.	If drive can communicate, CE can give a precise diagnosis. If not, refer to the Serial Communications part of the HCR for troubleshooting.
72	Flash memory error	Memory error detected when trying to load config from flash on powerup.	Restart device. No fix if restart doesn't work. Return to manufacturer for correction.

## Mounting the Drive

You can mount your drive on the wide or the narrow side of the chassis using (2) #6 screws. Since the drive amplifiers generate heat, the drive should be securely fastened to a smooth, flat metal surface that will help conduct heat away from the chassis. If this is not possible, then forced airflow from a fan may be required to prevent the drive from overheating.

- Never use your drive in a space where there is no air flow or where the ambient temperature exceeds 50 °C (122 °F).
- When mounting multiple STP-DRV-xxxx drives near each other, maintain at least one half inch of space between drives.
- Never put the drive where it can get wet.
- Never allow metal or other conductive particles near the drive.

### Drive Heating

For information on drive heating, please see Chapter 8: SureStep System Power Supplies.

## Dimensions and Mounting Slot Locations

### STP-DRV-4830

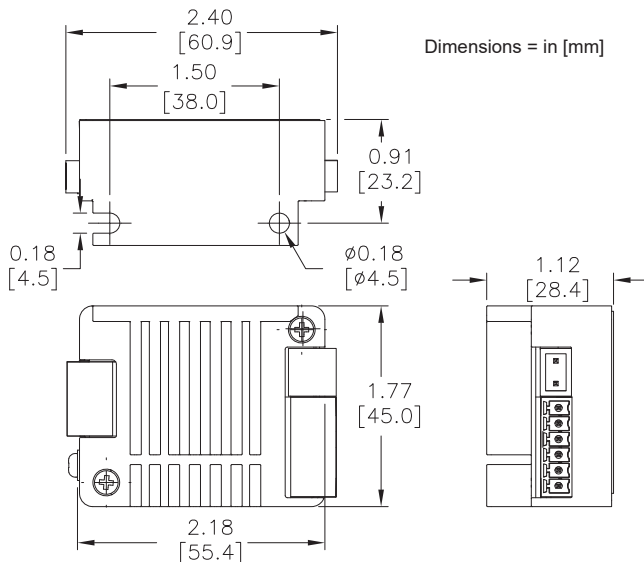

### STP-DRV-4845 and STP-DRV-6575

Dimensions = in [mm]

