



In This Chapter...

Features	5-2
Specifications	5-3
Mounting the Drive	5-4
Dimensions	5-4
Wiring Connections and Configuration Switches	5-5
STP-DRVAC-24025	5-5
Connecting the Power Supply	5-6
Connecting the Motor	5-7
Selecting the Motor.	5-8
Torque-Speed Curves	5-8
Connecting the I/O	5-9
Step/Direction Mode and CW/CCW Mode Jumper	5-9
Connecting the Input Signals - Step and Direction	5-9
The Enable Input.	5-10
Connecting the Fault Output Setting	5-11
Drive Configuration	5-12
Microstepping.	5-13
Setting Running Current	5-13
Idle Current Reduction	5-14
Step Noise Filter	5-14
Load Inertia.	5-14
Smoothing Filter	5-14
Self Test.	5-15
Alarm Codes.	5-16

Features

The STP-DRVAC-24025 AC input drive is based on advanced digital current control technology and provides high torque, low noise, and low vibration. Many of the operational parameters are switch selectable.

- Advanced digital current control provides excellent high speed torque
- Auto-setup probes the motor when power is applied and configures and fine tunes motor current control and anti-resonance gain settings
- Uses universal AC input 90 to 240 VAC, AC input voltage must be selected by switch
- Speed range - up to 50 rps
- Microstep resolution - switch selectable, 16 settings from 200 to 25600 steps/rev
- Running current - peak setting, switch selectable, 8 settings from 0.6 to 2.5 A
- Idle current -automatic reduction of running current 1 second after the motor stops, switch selectable, 2 settings, 50/90% of running current
- Anti resonance - raises the system-damping ratio to eliminate midrange instability and allow stable operation throughout the speed range of the motor, switch selectable, 2 settings, low to high inertia loads
- Control modes - step/direction pulse input (default) or CW/CCW pulse input, internal jumper switch selectable
- Input signal filter - filters out unwanted noise that can cause extra steps, switch selectable, 150kHz or 2MHz
- Step smoothing filter (microstep emulation) - performs high resolution stepping by synthesizing coarse steps into fine micro-steps, switch selectable, ON or OFF
- Self test - performs a 2 rev 0.5 rps, forward and reverse move test, switch selectable, ON or OFF
- Motor selection - a 16-bit rotary switch is used to select the desired motor database which is pre-loaded at the factory



Specifications

Sure Step™ Microstepping Drive Specifications		
Part Number	STP-DRVAC-24025	
Input Power	90–240 VAC	
Output Current	0.6–2.5 A	
Current Controller	MOSFET, dual H-bridge and 4-quadrant PWM at 20kHz	
Input Signals	Step	5 –24 VDC nominal (range: 4–28 VDC); optically isolated, differential. Maximum pulse frequency = 150kHz or 2MHz (user selectable). Minimum pulse width: 3 usec at 150 kHz setting SW9 1 usec at 2 MHz setting SW9 Function = Step or Step CW pulse.
	Direction	5 –24 VDC nominal (range: 4–28 VDC); optically isolated, differential. Maximum pulse frequency = 150kHz or 2MHz (user selectable). Minimum pulse width: 3 usec at 150 kHz setting SW9 1 usec at 2 MHz setting SW9 Function = Direction or Step CCW pulse.
	Enable	5 –24 VDC nominal (range: 4–30 VDC); (5mA @ 4V; 15 mA @ 30V); Optically isolated, differential. Max pulse frequency: 10kHz Minimum pulse width: 500usec Function = disable motor when closed.
Output Signal	Fault	30VDC max / 100mA max, optically isolated photodarlington, sinking or sourcing. Function = closes on drive fault.
Internal Jumper Selectable Function	Step Pulse Type	Step and Direction: Step signal = step/pulse; Direction signal = direction. Step CW & CCW: Step signal = CW step; Direction signal = CCW step.
DIP Switch Selectable Functions	Step Resolution	Selectable from 200 steps/rev up to 25600 steps/rev using SW1-4.
	Running Current	The output current drive to the motor is set by the SW5, SW6, and SW7 switches and can be changed from 0.6 A to 2.5 A per phase.
	Idle Current Reduction	Reduce power consumption and heat generation by limiting motor idle current to 90% or 50% of running current. (Holding torque is reduced by the same %.)
	Step Noise Filter	Select 150kHz or 2MHz using SW9.
	Load Inertia Smoothing Filter	Set the load inertia to 0-4x or 5-10x using SW10 (also referred to as anti-resonance) Softens the effect of immediate changes in velocity and direction, making the motion of the motor less jerky. Can cause a small delay in following the control signal.
	Selt Test	Automatically rotate the motor back and forth two turns in each direction in order to confirm that the motor is operational.
Drive Cooling Method	Natural cooling or fan-forced cooling	
Mounting	Use (2) M4 screws to mount to metal surface	
Removable Connectors*	DEGSON: 2EDGK-7.62-02P-14-00A(H), 2 pin power connector 2EDGK-5.08-04P-14-00A(H), 4 pin motor connector 15EDGK-3.81-08P-14-00A(H), 8 pin I/O connector	
Weight	0.88 kg [1lb 15oz]	
Operating Temperature	0–85 °C [32–185 °F] (interior of electronics section)	
Ambient Temperature	0–40 °C [32–104 °F]	
Humidity	Maximum 90% non-condensing	
Agency Approvals	CE, cUR _{us}	

*Replacement connectors are available in connector kit STP-CON-6

Mounting the Drive

The STP-DRVAC-24025 drive can be mounted only on the narrow side of the chassis using (2) M4 screws in the holes at the back of the drive. Use forced air cooling such as a fan to operate the drive continuously at maximum power.

WARNING:

- Never mount the drive in a space where there is no air flow, or where other devices can heat the surrounding air to 40°C [104°F].
- Never put the drive where it can get wet, or where metal or other electrically-conductive particles can get on the circuitry.
- Always provide air flow around the drive. Minimum allowable spacing between multiple drives is 0.5 inches [13 mm].

Dimensions

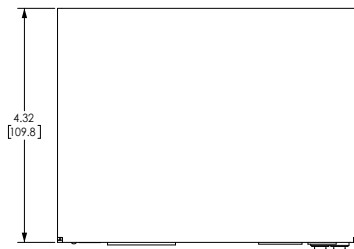
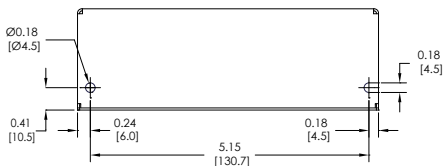

Dimensions = in [mm]

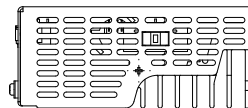
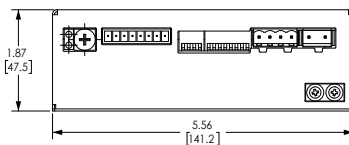

Wiring Connections and Configuration Switches

STP-DRVAC-24025

The following items are required to set up the STP-DRVAC-24025 drive:

- AC input of 90 to 240 VAC
- Pulse and direction signal
- A compatible step motor (STP-MTRAC-23 and -34 series recommended; the STP-MTRAC(H)-42x series will not work with this drive. The motors can accept the high voltage, but the drive does not supply enough current for the NEMA 42 motors)
- AC input voltage must be selected by switch

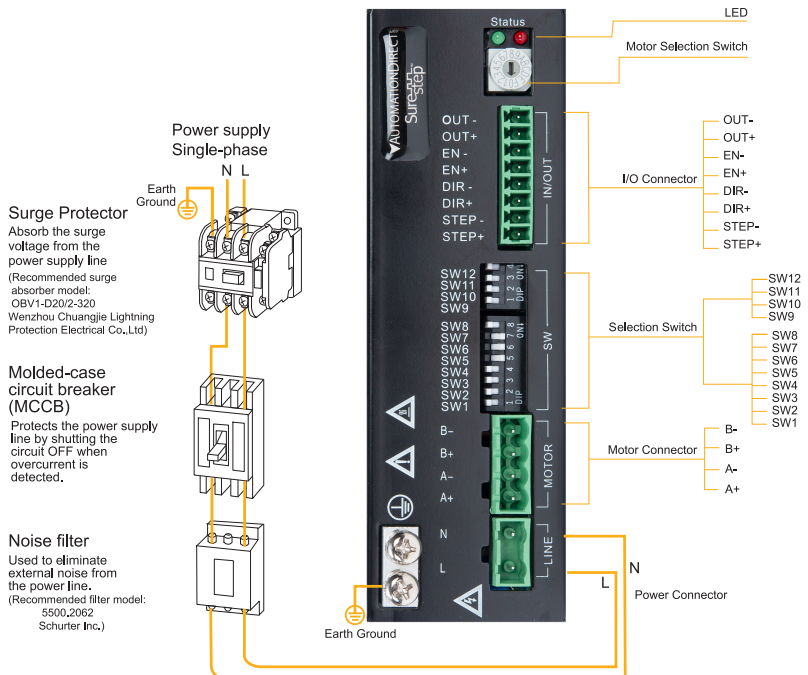

Connecting the Power Supply

DO NOT apply power until all connections to the drive have been made. Use a 4A fuse on the line connection for drive protection.

1. Select power input voltage. AC input voltage must be selected by switch. Check input voltage to avoid damage before powering on.



2. Wire the drive to the AC power source. Use 16 AWG wire for Line (L) and Neutral (N). Use 14 AWG for Earth Ground (G).

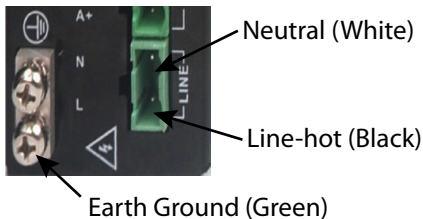

The STP-DRVAC-24025 contains a non-replaceable internal 5A fast acting fuse.



Warning: When connecting a step motor to the SureStep™ STP-DRVAC-24025 microstepping drive, be sure that the motor power supply is switched off. When using a motor not supplied by AutomationDirect, secure any unused motor leads so that they cannot short out to anything. Never disconnect the motor while the drive is powered up. Never connect motor leads to ground or to a power supply.

Connecting the Motor



Warning: When connecting a step motor to the SureStep™ STP-DRVAC-24025 microstepping drive, be sure that the motor power supply is switched off. When using a motor not supplied by *AutomationDirect*, secure any unused motor leads so that they cannot short out to anything. Never disconnect the motor while the drive is powered up. Never connect motor leads to ground or to a power supply.

Connect the drive to the motor. If using a non AutomationDirect motor, consult the motor specs for wiring information. It is very important to only use high bus voltage stepper motors with the STP-DRVAC-24025 as it outputs up to 340 volts to the motor. It is highly recommended that you use an AutomationDirect recommended motor that is equipped with a shielded cable. The NEMA23 and NEMA34 STP-MTRAC-x motors are specifically made to be used with the STP-DRVAC-24025 drive.

Always connect the motor's cable drain wire to the two screws next to the A+ terminal. The connecting of this drain wire not only grounds the motor frame but also connects the cable shield to minimize electrical interference.

The recommended AutomationDirect step motors for the STP-DRVAC-24025 include shielded cables and should always be wired in the series configuration as shown below. The STP-DRVAC-24025 has an internal voltage doubler when connected to 115VAC so the series configuration is required in order to limit the current output of the drive. If you are using a different manufacturer's drive that does not have a voltage doubler when connected to 110VAC then you should wire the STP-MTRAC-x motors in parallel to achieve the same phase current.

STP-MTRAC-23044(x), 23055(x),
23078(x), 34156(x)

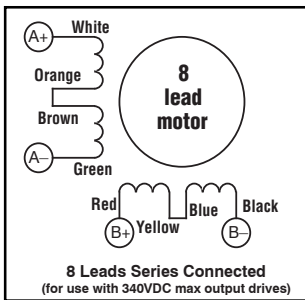

STP-MTRAC-34075(x), 34115(x)

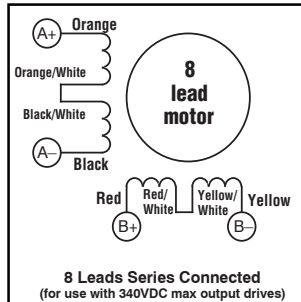

WARNING:
Always wire STP-MTRAC motors in series when using the STP-DRVAC-24025.

Selecting the Motor

Each position of the 16-bit rotary switch selects a different motor, automatically setting the configuration parameters in the drive. The STP-DRVAC-24025 drive comes programmed with up to 6 SureStep motors as factory defaults. The remaining options are either reserved for future or factory use.



Warning: Do NOT use standard low-voltage stepper motors with the AC-input drive. Only use stepper motors rated for AC-input systems (such as the STP-MTRAC motors). The high bus voltage on the STP-DRVAC drive will overheat and damage standard stepper motors that are wound for lower-voltage DC systems.

If the motor selection is changed, the drive power supply will need to be cycled.



NOTE: Motor current is limited by the lower value between rotary switch setting and the Running Current dip switches. The default setting for the running current is 0.6 A for motor protection. Be sure to adjust this setting when selecting a motor.

For a custom motor, please select the closest comparable motor via the rotary switch, then use the DIP switches to configure motor current, anti-resonance, and other settings.

STP-DRVAC-24025 Motor Selection			
Rotary Switch Position	Motor	Rated Current (A/phase RMS)	Wiring
0-6	Reserved		
7	STP-MTRAC-23044(D)	0.71	Series
8	STP-MTRAC-23055(D)	0.71	Series
9	STP-MTRAC-23078(D)	0.71	Series
A	STP-MTRAC-34075(D)	2.15	Series
B	STP-MTRAC-34115(D)	2.05	Series
C	STP-MTRAC-34156(D)	2.55	Series
D-F	Reserved		

Connecting the I/O

The SureStep STP-DRVAC-24025 drive includes two high-speed 5–24 VDC digital inputs (STEP & DIR, or CW/CCW) accepting single-ended or differential signals, up to 2MHz depending on DIP SW9 selection, one 5–24 VDC digital input (EN), and one digital output (Fault).

The digital inputs are optically isolated to reduce electrical noise problems. There is no electrical connection between the control and power circuits within the drive, and input signal communication between the two circuits is achieved by infrared light.

For bidirectional rotation, supply a source of step pulses to the drive at the STEP+ and STEP– terminals, and a directional signal at the DIR+ and DIR– terminals.

The ENABLE input allows the logic to turn off the current to the step motor by providing a signal to the EN+ and EN– terminals.

All logic inputs can be controlled by a DC output signal that is either sinking (NPN), sourcing (PNP), or differential.

On the next couple of pages are examples for connecting various forms of outputs from both indexers and PLCs.

Step/Direction Mode and CW/CCW Mode Jumper

To adjust the STP-DRVAC-24025 drive to accept STEP CW and STEP CCW signals, remove the drive cover and move jumper J10 from the 1-2 position to the 2-3 position. Jumper J10 is located at the top of the main circuit board, just behind the white 4-pin connector. The CW signal should be connected to the STEP input and the CCW signal should be connected to the DIR input.

Connecting the Input Signals - Step and Direction

Connecting Drive to Indexer with Sourcing Outputs

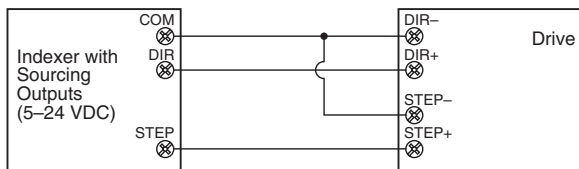

Connecting Drive to Indexer with Sinking Outputs

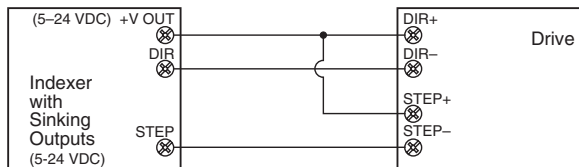

Connecting Drive to Indexer with Differential Outputs

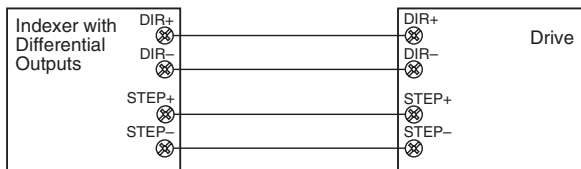

The Enable Input

The **ENABLE** input allows the user to turn off the current to the motor by providing a positive voltage between EN+ and EN-. The logic circuitry continues to operate, so the drive “remembers” the step position even when the amplifiers are disabled. However, the motor may move slightly when the current is removed depending on the exact motor and load characteristics.

Connecting Drive EN to Switch or Relay

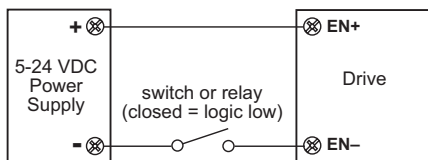

Connecting Drive EN to NPN

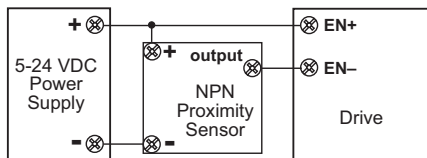

Connecting the Fault Output Setting

The SureStep STP-DRVAC-24025 has one digital output that has separate positive (+) and negative (-) terminals, and can be used to sink or source current. Do not connect more than 30VDC. Current must not exceed 80mA.

Connecting Drive's Fault Output to Inductive Relay

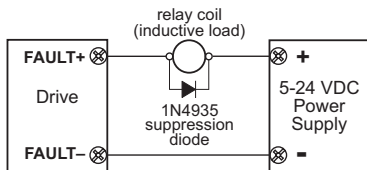

Connecting Fault Output as Sinking Output

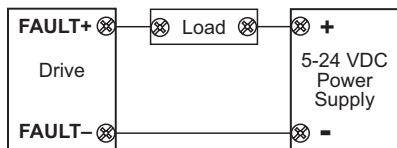

Connecting Fault Output as Sourcing Output

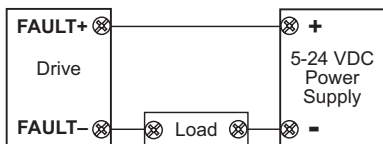

Drive Configuration

You need to configure your drive for your particular application before using the drive for the first time. The SureStep STP-DRVAC-24025 microstepping drive offers several features and configuration settings, including:

<i>Drive Configuration Settings</i>		
<i>Feature</i>	<i>Description</i>	<i>Configuration Method</i>
Motor Phase Current	Select motor based on part number. Automatically sets drive to run the selected motor as optimally as possible.	Choose motor via rotary switch
Mode of Operation (Step Pulse Type)	Step and Direction (default): Step signal = step/pulse; Direction signal = direction. Step CW & CCW: Step signal = CW step; Direction signal = CCW step.	Jumper J10
Step Pulse Noise Filter	Select 150 kHz or 2MHz	DIP switch SW9
Running Current	The output current is set by the SW5, SW6 and SW7 switches. NOTE: Drive's running current will be limited by the lower value between motor selection rotary switch or the dip current switch	DIP switch SW5, SW6, SW7
Idle Current Reduction	Reduce power consumption and heat generation by limiting motor idle current to 90% or 50% of running current. (Holding torque is reduced by the same %.)	DIP switch SW8
Load Inertia	Anti-resonance and damping feature improve motor performance. Set motor and load inertia range to 0–4x or 5–10x.	DIP switch SW10
Step Resolution	For smoother motion and more precise speed, set the pulse per revolution value as needed.	DIP switch SW1, SW2, SW3, SW4
Self Test	Automatically rotates the motor back and forth 1/2 a revolution in each direction in order to confirm that the motor is operational.	DIP switch SW12
Step Smoothing Filter	Softens the effect of immediate changes in velocity and direction, making the motion of the motor less jerky. Can cause a small delay in following the control signal.	DIP switch SW11

Microstepping

The microstep resolution is set by the SW1, SW2, SW3, and SW4 switches. There are 16 settings.

Please refer to the table below and set the switches for the resolution you want.

STP-DRVAC-24025 Microstep Table				
MicroStep	Switch 1	Switch 2	Switch 3	Switch 4
200	ON	ON	ON	ON
400	OFF	ON	ON	ON
800	ON	OFF	ON	ON
1600	OFF	OFF	ON	ON
3200	ON	ON	OFF	ON
6400	OFF	ON	OFF	ON
12800	ON	OFF	OFF	ON
25600	OFF	OFF	OFF	ON
1000	ON	ON	ON	OFF
2000	OFF	ON	ON	OFF
4000	ON	OFF	ON	OFF
5000	OFF	OFF	ON	OFF
6000	ON	ON	OFF	OFF
8000	OFF	ON	OFF	OFF
10000	ON	OFF	OFF	OFF
20000	OFF	OFF	OFF	OFF

Setting Running Current

Before you turn on the power supply the first time, you need to set the drive for the proper motor running current. The rated current is usually printed on the motor label. The SureStep drive current is easy to set using the table below:

STP-DRVAC-24025 Running Current Table			
Peak A	Switch 5	Switch 6	Switch 7
0.6	ON	ON	ON
0.8	OFF	ON	ON
1.0	ON	OFF	ON
1.2	OFF	OFF	ON
1.6	ON	ON	OFF
1.8	OFF	ON	OFF
2.0	ON	OFF	OFF
2.5	OFF	OFF	OFF

Idle Current Reduction

Your drive is equipped with a feature that automatically reduces the motor current by 50% anytime the motor is not moving. This reduces drive heating by about 50% and lowers motor heating by 75%. This feature can be disabled if desired so that full current is maintained at all times. This is useful when a high holding torque is required. To minimize motor and drive heating we highly recommend that you enable the idle current reduction feature unless your application strictly forbids it.

Idle current reduction is enabled by flipping switch SW8 toward the ON position, as shown in the sketch at right. Flipping the switch to the OFF position disables the reduction feature.

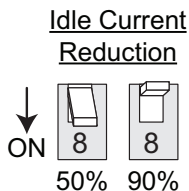

Step Noise Filter

Filters out unwanted noise that can cause extra steps. Set the switch SW9 to the ON position to set filter frequency to 150kHz. Set the switch to the OFF position to set the filter frequency to 2MHz.

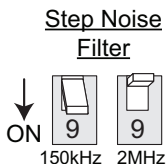

Load Inertia

Step motor systems have a tendency to resonate at certain speeds. The load inertia setting applies damping to the control algorithm. This greatly improves midrange stability, allows higher speeds and greater torque utilization, and improves settling times.

Load inertia is set to the 0-4x setting by flipping switch SW10 to the ON position, or 5-10x inertia by flipping the switch to the OFF position.

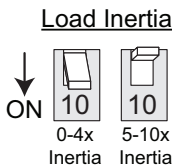

Smoothing Filter

The Step Smoothing Filter setting is effective only in the Step (Pulse) & Direction mode. It includes command signal smoothing and microstep emulation to soften the effect of immediate changes in velocity and direction, therefore making the motion of the motor less jerky. An added advantage is that it can reduce the wear on mechanical components.

The smoothing filter is enabled when switch SW11 is in the ON position, and disabled when the switch is in the OFF position.

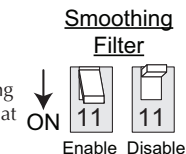

NOTE: The power must be cycled each time the position of switch 9 or switch 11 is changed.

Self Test





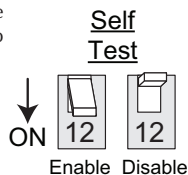















The SureStep drive includes a self test feature. This is used for trouble shooting. If you are unsure about the motor or signal connections to the drive, or if the SureStep drive isn't responding to your step pulses, you can turn on the self test.

To activate the self test, flip switch SW12 to the ON position. The drive will slowly rotate the motor, 1/2 revolution forward, then 1/2 rev backward. The pattern repeats until you flip the switch to the OFF position. The SureStep drive always uses half step mode during the self test. The self test ignores the STEP and DIRECTION inputs while operating. The ENABLE input continues to function normally.



Alarm Codes

In the event of a drive fault or alarm, the green LED will flash one or two times, followed by a series of red flashes. The pattern repeats until the alarm is cleared.

STP-DRVAC-xxxx Alarm Codes		
Alarm Code	LED Sequence	Alarm Description
SG	 Solid green	No alarm, motor disabled
FG	 Fast green	Factory use
01	 Flashing green	No alarm, motor enabled
10	 Flashing red	Configuration or memory error ¹
11	 1 red, 1 green	Motor stall (optional encoder only) ⁴
12	 1 red, 2 green	Move attempted while drive disabled
21	 2 red, 1 green	CCW limit
22	 2 red, 2 green	CW limit
31	 3 red, 1 green	Drive overheating
32	 3 red, 2 green	Internal voltage out of range ²
33	 3 red, 3 green	Factory use
41	 4 red, 1 green	Power supply overvoltage ²
42	 4 red, 2 green	Power supply undervoltage
43	 4 red, 3 green	Flash memory backup error
51	 5 red, 1 green	Over current / short circuit ^{2, 3}
52	 5 red, 2 green	Excess regeneration
61	 6 red, 1 green	Open motor winding ²
62	 6 red, 2 green	Bad encoder signal (optional encoder only) ⁴
71	 7 red, 1 green	Serial communication error ⁵
72	 7 red, 2 green	Flash memory error

1 - Does not disable the motor.
The alarm will clear about 30 seconds after the fault is corrected.

2 - Disables the motor. Cannot be cleared until power is cycled.

3 - The over-current/short-circuit alarm typically indicates that an electrical fault exists somewhere in the system external to the drive. This alarm does not serve as motor overload protection.

4 - This alarm only occurs on STP-MTRD advanced integrated motor/drives

5 - This alarm only occurs on drives with serial communication.

Alarm Code Definitions

Alarm Code	Error	Description	Corrective Action
SG	No alarm, motor disabled	No faults active, Circuit is closed between EN+ and EN-.	N/A
01	No alarm, motor enabled	No faults active, Circuit is open between EN+ and EN-.	N/A
10	Configuration or memory error	Memory error detected when trying to load config from flash on powerup.	Restart device. No fix if restart doesn't work. Return to manufacturer for correction.
11	Motor stall (optional encoder only)	Motor torque demand exceeded capability and the motor skipped steps. This is configured in SureMotion Pro.	Increase torque utilization if it's not already maxed out, otherwise decrease the torque demand by modifying the move profile, or put in a larger motor.
12	Move attempted while drive disabled	Drive is disabled and move attempted.	Reset alarm, enable motor, and move again.
21	CCW limit	CCW limit is reached. The digital input that has been assigned CCW limit has been activated.	Unblock the CCW sensor (open the circuit) or redefine the input with SureMotion Pro.
22	CW limit	CW limit is reached. The digital input that has been assigned CW limit has been activated.	Unblock the CCW sensor (open the circuit) or redefine the input with SureMotion Pro.
31	Drive overheating	The drive's internal temperature is too high.	If the drive is operating within its standard range (input voltage and output current are OK), more heat must be removed from the drive during operation. For Advanced drives (see "Mounting the Drive" on page 4-14), ensure the drive is mounted to a metal surface that can dissipate the drive's heat. For Integrated motor/drives, see "Mounting" on page 5-13. For both types of drives: If the mounting surface cannot pull enough heat away from the drive, forced airflow (from a fan) may be required to cool the drive.
32	Internal voltage out of range	Gate voltage, 5V rail, or 3V rail are out of spec.	Ensure adequate supply voltage (in very rare cases, low input voltages combined with fast accelerations can draw down the gate voltage) and try again. If persistent, RMA is required.

Alarm Code	Error	Description	Corrective Action
41	Power supply overvoltage	The AC voltage feeding the drive is above the allowable level.	Limit the input voltage to the drive to 145VAC if the voltage switch is set for 115V. If the voltage switch is set for 230V, limit the input voltage to 295VAC.
42	Power supply undervoltage	The AC voltage feeding the drive is below the allowable level.	Ensure the input voltage to the drive is at least 75VAC if the voltage switch is set for 115V. If the voltage switch is set for 230V, ensure the input voltage is at least 135VAC.
43	Flash memory backup error	Memory error detected when trying to load config from flash on powerup.	Restart device. No fix if restart doesn't work. Return to manufacturer for correction.
51	Over current / short circuit	Motor leads shorted - only checked on powerup.	Check and fix motor wiring.
52	Excess regen	Too much regenerative energy is being fed from the motor back into the drive.	Excess Regen typically occurs when a motor is being pushed by load (overhauling load) or the motor is trying to decelerate the load too quickly. Reduce the backdriving force, lengthen the deceleration ramp, or increase the size of the motor.
61	Open motor winding	Motor leads not connected - only checked on powerup.	Check and fix motor wiring.
62	Bad encoder signal (optional encoder only)	Noisy or otherwise incorrectly formatted encoder signal (lack of A or B, lack of differential signal).	Check encoder wiring, always use differential encoders (or use checkbox in SureMotion Pro to disable this error when using single ended).
71	Serial communication error	Catch-all error for something wrong with serial communications. See CE command in HCR for details.	If drive can communicate, CE can give a precise diagnosis. If not, refer to the Serial Communications part of the HCR for troubleshooting.
72	Flash memory error	Memory error detected when trying to load config from flash on powerup.	Restart device. No fix if restart doesn't work. Return to manufacturer for correction.