



In This Chapter...

Features	7-2
Design and Installation Tips	7-3
Specifications	7-4
Power Supply and Step Motor Drive.	7-7
Mounting the Motor	7-7
Connecting the Motor	7-7
Extension Cable Wiring Diagrams	7-8
Connecting a STP-MTRAC Motor	7-8
Motor Dimensions and Cabling	7-10
Typical Dimension & Cable Diagrams	7-10
Typical Dimension & Cable Diagram for STP-MTRH	7-13
Typical Dimension & Cable Diagram for STP-MTRAC	7-16
Torque vs. Speed Charts.	7-18

Features

- Step motors available in NEMA 14, NEMA 17, NEMA 23, NEMA 34, and NEMA 42 frame sizes.
- Square frame style produces high torque and achieves best torque to volume ratio.
- Holding torque ranges from 8 to 4532 oz-in.
- Available in single-shaft, dual-shaft (encoder ready), encoder mounted, IP65 (wash-down), and high bus voltage configurations.
- 12-inch long connectorized cables attached to motors, with extension cables available in 6, 10, and 20 foot lengths. NEMA 23 and NEMA 34 high-bus voltage models (MTRAC-23 and MTRAC-34) have 10' long non-connectorized 8-lead cables.
- All NEMA 14, NEMA 17, NEMA 23, NEMA 34, and NEMA 42 dual-shaft motors come with pretapped holes ready for a modular encoder to be mounted.
- All “E” models include a premounted line driver encoder AMT112Q-V (replaces STP-MTRA-ENC9). The AMT112Q-V is a configurable encoder that comes preconfigured with 400ppr when shipped attached to a motor. Other ppr and output types are available for purchase. See Appendix A for more information on encoder options and configuration utility.
- All “W” model motors and extension cables include an IP65 connector attached to the cable.

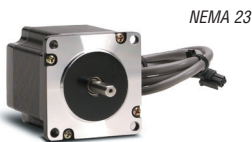

Note: Small holes are often drilled into the end of the rotor shaft. This is for manufacturing tooling purposes. These holes do not have a dimensional tolerance and cannot be guaranteed to be present on subsequent orders.



Dual-shaft Versions Available



Encoder Versions Available

IP65 Versions Available



Design and Installation Tips

Allow sufficient time to accelerate the load and size the step motor with a 100% torque safety factor (i.e. design the system using a maximum of 50% of the motor's torque). DO NOT disassemble step motors, as motor performance will be reduced and the warranty will be voided. DO NOT connect or disconnect the step motor during operation.

The motor can be mounted in any orientation (horizontal or vertical). Mount it to a surface with good thermal conductivity, such as steel or aluminum, to allow heat dissipation. Use a flexible coupling with “clamp-on” connections to both the motor shaft and the load shaft to prevent thrust and radial loading on bearings from minor misalignment.

In general, the higher the current into a step motor the higher the torque, especially at lower speeds. The higher the voltage to the step motor, the higher the torque at higher speeds. Losses come in to play here, too. The higher you run the current on the motors, the higher your losses are going to be, and the hotter your motors are going to get. For this reason, AutomationDirect specs current for motors at the RMS value. This is the value on the motor's label and specification table. This guarantees a very long life for the motor. Multiplying the motor's RMS phase current by 1.2 gives a good balance of torque vs loss. This value should then be used to set the drive's peak phase current. Note that the whole speed torque curve won't be shifted up, only the low speed flat part before the torque starts dropping. The curve can drop for many reasons, but typically it's due to not having enough voltage to push the desired current into the windings, so increasing the voltage is what gives you a boost there, not making more current available.

For STP-MTRAC(H)-x motors or other high bus voltage motors ensure the drain wire or ground wire from the motor is properly grounded to the motor and drive's grounding lug. Also ensure the drive's grounding point is properly grounded to the panel ground.

Specifications

SureStep™ Series Specifications – Connectorized Bipolar Stepping Motors							
Bipolar Stepping Motors	Low Torque Motors		High Torque Motors				
	STP-MTRL-14026x	STP-MTRL-14034x	STP-MTR-17040x	STP-MTR-17048x	STP-MTR-17060x	STP-MTR-23055x	
NEMA Frame Size	14	14	17	17	17	23	
Optional Encoder	Y	Y	Y	Y	Y	Y	
* Max Holding Torque	(lb-in)	0.5	1.25	3.81	5.19	7.19	10.37
	(oz-in)	8	20	61	83	115	166
	(N-m)	0.06	0.14	0.43	0.59	0.81	1.17
Rotor Inertia	(oz-in ²)	0.06	0.08	0.28	0.37	0.56	1.46
	(kg-cm ²)	0.0003	0.00035	0.05	0.07	0.10	0.27
Rated RMS Current (A/phase)	0.35	0.8	1.7	2.0	2.0	2.8	
Resistance (Ω/phase)	8.5	7.66	1.6	1.4	2.0	0.75	
Inductance (mH/phase)	5.77	6.92	3.0	2.7	3.3	2.4	
Insulation Class	130°C [266°F] Class B; 300V rms						
Basic Step Angle	1.8°						
Shaft Runout	0.002 in [0.051 mm]						
Max Shaft Radial Play @ 1lb load	0.001 in [0.025 mm]						
Perpendicularity	0.003 in [0.076 mm]						
Concentricity	0.003 in [0.076 mm]						
*Max Radial Load (lb [kg])	6.0 [2.7]					15.0 [6.8]	
*Max Axial (Thrust) Load (lb [kg])	6.0 [2.7]					13.0 [5.9]	
Storage Temperature	-20°C to 100°C [-4°F to 212°F]						
Operating Temperature	-20°C to 50°C [-4°F to 122°F] (motor case temperature should be kept below 80°C [176°F])						
Operating Humidity	55% to 85% non-condensing						
Product Material	steel motor case; stainless steel (SUS 303) shaft(s)						
Environmental Rating	IP40		IP40 IP65 (W motors only)				
Weight (lb [kg]) (E models)	0.25 [0.11] (0.3 [0.11])	0.35 [0.15] (0.4 [0.2])	0.6 [0.3] (0.7 [0.3])	0.7 [0.3] (0.8 [0.4])	0.9 [0.4] (0.9 [0.4])	1.5 [0.7] (1.5 [0.7])	
Agency Approval	CE						
Accessory Extension Cable	STP-EXTL-006, 010, 020		STP-EXT-006, 010, 020 STP-EXTW-006, 010, 020 (W motors only)				
* For dual-shaft motors (STP-MTR-xxxxxD): The sum of the front and rear Torque Loads, Radial Loads, and Thrust Loads must not exceed the applicable Torque, Radial, and Thrust load ratings of the motor.							

Specifications (continued)

Table continued from previous page							
SureStep™ Series Specifications – Connectorized Bipolar Stepping Motors							
Bipolar Stepping Motors	High Torque Motors		Higher Torque Motors				
	STP-MTR-23079x	STP-MTR-34066x	STP-MTRH-23079x	STP-MTRH-34066x	STP-MTRH-34097x	STP-MTRH-34127x	
NEMA Frame Size	23	34	23	34	34	34	
Optional Encoder	Yes						
Max Torque	(lb-in)	17.25	27.12	17.87	27.12	50.00	80.50
Holding Torque	(oz-in)	276	434	286	434	800	1288
	(N-m)	1.95	3.06	2.02	3.06	5.65	9.10
Rotor Inertia	(oz-in ²)	2.60	7.66	2.60	7.66	14.80	21.90
	(kg-cm ²)	0.48	1.40	0.48	1.40	2.71	4.01
Rated RMS Current (A/phase)		2.8	2.8	5.6	6.3	6.3	6.3
Resistance (Ω/phase)		1.1	1.11	0.4	0.25	0.3	0.49
Inductance (mH/phase)		3.8	6.6	1.2	1.5	2.1	4.1
Insulation Class	130°C [266°F] Class B; 300V rms						
Basic Step Angle	1.8°						
Shaft Runout	0.002 in [0.051 mm]						
Max Shaft Radial Play @ 1lb load	0.001 in [0.025 mm]						
Perpendicularity	0.003 in [0.076 mm]						
Concentricity	0.003 in [0.076 mm]						
Maximum Radial Load (lb [kg])	15.0 [6.8]	39.0 [17.7]	15.0 [6.8]	39.0 [17.7]			
Max Axial (Thrust) Load (lb [kg])	13.0 [5.9]	25.0 [11.3]	13.0 [5.9]	25.0 [11.3]			
Storage Temp.	-20°C to 100°C [-4°F to 212°F]						
Operating Temperature	-20°C to 50°C [-4°F to 122°F] (motor case temperature should be kept below 80°C [176°F])						
Operating Humidity	55% to 85% non-condensing						
Product Material	steel motor case; stainless steel (SUS 303) shaft(s)						
Environmental Rating	IP40						
	IP65 (W motors only)						
Weight (lb [kg]) (E models)	2.2 [1.0] (2.4 [1.1])	3.9 [1.7]	2.4 [1.1] (2.4 [1.1])	3.9 [1.7]	5.9 [2.7]	8.4 [3.8]	
Agency Approval	CE						
Accessory Extension Cable	STP-EXT-006, 010, 020 STP-EXTW-006, 010, 020 (W motors only)		STP-EXTH-006, 010, 020 STP-EXTWH-006, 010, 020 (W motors only)				

Specifications (continued)

Table continued from previous page

SureStep™ Series Specifications – Non-connectorized Bipolar Stepping Motors							
Bipolar Stepping Motors		High Bus Voltage Motors					
		STP-MTRAC-23044(x)	STP-MTRAC-23055(x)	STP-MTRAC-23078(x)	STP-MTRAC-34075(x)	STP-MTRAC-34115(x)	STP-MTRAC-34156(x)
NEMA Frame Size		23	23	23	34	34	34
Optional Encoder ¹		Y	Y	Y	Y	Y	Y
Max Holding Torque	(lb-in)	4.69	9.31	14.19	51.31	69.38	115.06
	(oz-in)	75	149	227	821	1110	1841
	(N-m)	0.53	1.05	1.6	5.8	7.84	13
Rotor Inertia	(oz-in ²)	0.66	1.64	2.62	7.38	14.74	24.06
	(g-cm ²)	120	300	480	1350	2700	4400
Rated RMS Current (A/phase)	Series	0.71	0.71	0.71	2.15	2.05	2.55
	Parallel	1.41	1.41	1.41	4.3	4.1	5.1
Resistance (Ω/phase)	Series	12.4	14.4	18	4	4.8	4.8
	Parallel	3.1	3.6	4.5	1.0	1.2	1.375
Inductance (mH/phase)	Series	30.4	51.2	60.8	32	43.2	44.8
	Parallel	7.6	12.8	15.2	8.0	10.8	11.2
Insulation Class		B					
Steps per Revolution		200					
Basic Step Angle		1.8°					
Shaft Runout		0.05 mm					
Max Shaft Radial Play @ 1lb load		0.02 in			0.025 in		0.02 in
Max End Play @ 2.2-lb Axial Load		0.08 in			0.075 in		0.08 in
Connectors		8 leads, 24AWG			8 leads, 22AWG		
Temperature Rise		80°C max					
Storage Temp.		-40°C to 70°C [-40°F to 158°F]					
Operating Temperature		-20°C to 50°C [-4°F to 122°F]					
Operating Humidity		5% to 95% non-condensing					
Product Material		Steel motor case, stainless steel shaft(s)					
Environmental Rating		IP40					
Weight (lb [kg])		1.03 [0.47]	1.54 [0.7]	2.2 [1.0]	4.2 [1.9]	8.4 [3.8]	11.464 [5.2]
Agency Approval		None			cUR _{us}		

1 - Only Dual-shaft motors (suffix = "D") are encoder ready.

Specifications (continued)

SureStep™ Series Specifications – Connectorized Stepping Motors							
Stepping Motors	Higher Bus Voltage Motors						
	STP-MTRAC-42100x	STP-MTRAC-42151x	STP-MTRAC-42202x	STP-MTRAC-42100x	STP-MTRAC-42151x	STP-MTRAC-42202x	
NEMA Frame Size	42	42	42	42	42	42	
Optional Encoder ¹	Y	Y	Y	Y	Y	Y	
Max Holding Torque (N-m)	<i>Unipolar Series</i>	9.7	19.0	26.0	9.7	17.5	26.0
	<i>Bipolar Series</i>	12.2	22.0	31.0	12.3	22.0	32.0
	<i>Bipolar Parallel</i>	12.2	22.0	31.0	12.3	22.0	32.0
Rotor Inertia (g-cm ²)	5500	10900	16200	5500	10900	16200	
Rated RMS Current (A/phase)	<i>Unipolar Series</i>	6	9.4	9	8.5	11.3	11.5
	<i>Bipolar Series</i>	4.2	6	6	6	8	8
	<i>Bipolar Parallel</i>	8.4	12	12	12	16	16
Resistance (Ω/phase)	<i>Unipolar Series</i>	0.6	0.34	0.46	0.32	0.215	0.29
	<i>Bipolar Series</i>	1.19	0.68	0.91	0.64	0.43	0.58
	<i>Bipolar Parallel</i>	0.3	0.17	0.23	0.159	0.108	0.144
Inductance (mH/phase)	<i>Unipolar Series</i>	5	3.6	5.5	2.5	1.9	3.2
	<i>Bipolar Series</i>	19.8	14.5	22	10.1	7.6	13
	<i>Bipolar Parallel</i>	5	3.6	5.5	2.5	1.9	3.2
Insulation Class	B						
Steps per Revolution	200						
Basic Step Angle	1.8°						
Shaft Runout	0.05 mm						
Max Shaft Radial Play @ 1lb load	1.1 in						
Connectors	8 leads, 18AWG						
Temperature Rise	80°C max						
Storage Temp.	-30°C to 70°C [-22°F to 158°F]						
Operating Temperature	-20°C to 40°C [-4°F to 104°F]						
Operating Humidity	5% to 95% non-condensing						
Product Material	Steel motor case, stainless steel shaft(s)						
Environmental Rating	IP40						
Weight (lb [kg])	10.6 [4.8]	17.6 [8]	25.6 [11.6]	10.6 [4.8]	17.6 [8]	25.6 [11.6]	
Agency Approval	cUR _{US}						

¹ - Only Dual Shaft motors (suffix = "D") are Encoder Ready. NEMA 42 motors require an STP-MTRA-42ENC adapter plate for encoder mounting (holes pre-drilled and tapped for CUI Devices AMT31/AMT33 or US Digital E6).

Power Supply and Step Motor Drive

An STP-PWR-xxxx linear power supply from AutomationDirect is the best choice to power AutomationDirect and other DC-input stepper drives. These power supplies were designed to work with the AutomationDirect SureStep™ STP-DRV-xxxx series bipolar DC microstepping motor drives. PSBxx switching power supplies are also available from AutomationDirect.



SureStep STP-MTRAC series motors (NEMA23 and NEMA34 only) and STP-DRVAC drives are designed for high bus voltages (120VAC, 240VAC drive input). Higher DC power supply voltages and AC-input stepper drives generate very high bus voltages and will result in excessive losses (heat) in the motors unless they are designed for it (see STP-MTRAC motors and STP-DRVAC drives). Do not use low-voltage motors in a high bus voltage system.

Always check the motor specs and speed-torque curves to determine allowable drive input voltage. To minimize heat loss in the motor, always choose the lowest input voltage that satisfies the application's speed-torque requirements.

Mounting the Motor

We recommend mounting the motor to a metallic surface to help dissipate heat generated by the motor.

Connecting the Motor



W : When connecting a step motor to a drive or indexer, be sure that the motor power supply is switched off. Never disconnect the motor while the drive is powered up. Never connect the motor leads to ground or directly to the power supply.

All SureStep STP-MTR series motors have connectorized cables which connect directly to available SureStep extension cables. Due to the different current ranges of the three motor torque classes, three different ampacity rated cables are available in three different lengths. The MTRL motors use EXTL cables, the MTR motors use EXT cables, and the MTRH motors use EXTH cables. The extension cables have the same wire color coding as the motor pigtail cables, as shown in the extension cable wiring diagram and in the motor dimension and cabling diagram. The NEMA 23 and NEMA 34 high bus voltage MTRAC motors have 8-lead, 10-foot cables (no in-line connectors or extension cables). NEMA 42 STP-MTRAC(H)-42x motors have a connectorized cable that will mate with the STP-EXT42(H) extension cables.

Extension Cable Wiring Diagrams

STP-EXTx-xxx Cables

EXT & EXTH CABLES

PIN#	COLOR	PHASE
1	RED	A+
2	WHITE	A-
3	GREEN	B+
4	BLACK	B-

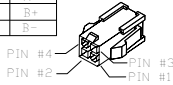

EXTL CABLES

PIN#	COLOR	PHASE
1	RED	A+
2	WHITE	A-
3	GREEN	B+
4	BLACK	B-



CONNECTORS:

EXT: Molex #43020-0401

EXTH: Molex #39-01-2041

EXTL: TE #103653-3

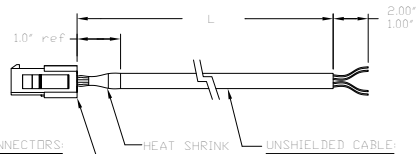
24AWG = EXTL cables
20AWG = EXT cables
18AWG = EXTH cables

STP-EXTxW-xxx Cables

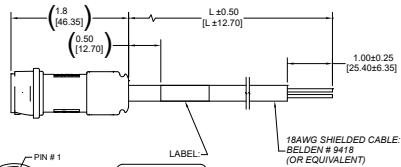
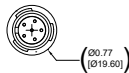

PIN OUT CONNECTION		
PIN #	COLOR	PHASE
1	RED	A+
2	WHITE	A-
3	GREEN	B+
4	BLACK	B-
5	GROUND	GROUND
6	N/A	N/A

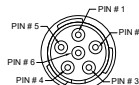
VIEW FROM PIN CONNECTION
Connector: Bulgin # PXP4011/06P/055STP-EXTW-0XX
or
STP-EXTHW-0XX

STP-EXT42(H)-xxx Cables

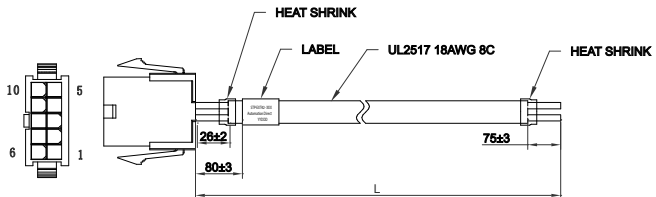

Pin	Wire Description
1	A - White
2	Ā - Orange
3	C - Green
4	C̄ - Brown
5	B - Red
6	B̄ - Yellow
7	D - Black
8	D̄ - Blue
9	GND - Drain wire

For stepper drive connections (A+, A-, B+, B-), see wiring diagrams on page 7-11.

Connecting a STP-MTRAC-23x or STP-MTRAC-34x Motor

The NEMA 23 and NEMA 34 STP-MTRAC series high bus voltage motors have eight leads and should be wired using the diagrams below:

STP-MTRAC-230xx(x), 34156(x)

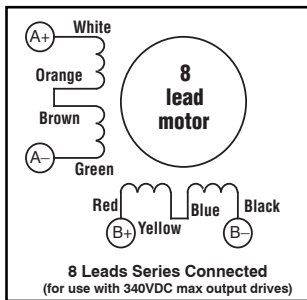

Use the series winding diagram with STP-DRVAC-24025 drives (115 or 230 VAC)

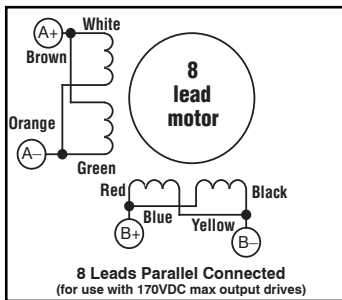

Warning!! Do NOT use this parallel winding diagram with STP-DRVAC-24025 drives

STP-MTRAC-34075(x), 34115(x)

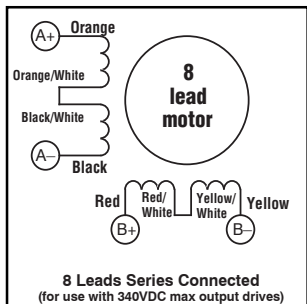

Use the series winding diagram with STP-DRVAC-24025 drives (115 or 230 VAC)

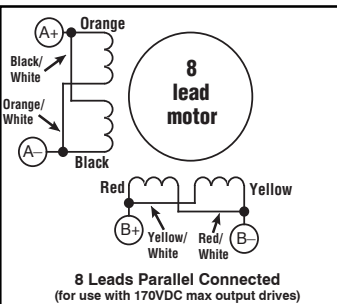

Warning!! Do NOT use this parallel winding diagram with STP-DRVAC-24025 drives

Connecting a STP-MTRAC(H)-42 Motor

The STP-MTRAC(H)-42 series higher bus voltage motors have eight leads and should be wired using the diagrams below:

Uni-polar

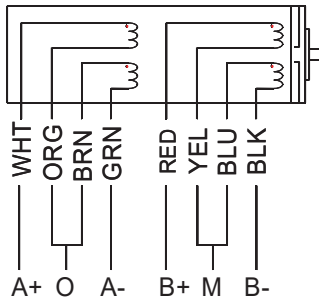

Bi-polar series

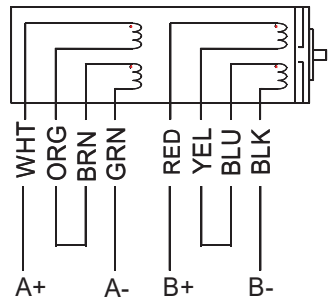

Bi-polar parallel

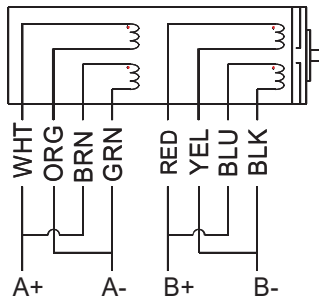

NOTE: Bipolar Series will be the most common application. The larger Bipolar Parallel motors require 12A and 16A current from a stepper drive.

Motor Dimensions and Cabling

Typical Dimension & Cable Diagrams

STP-MTR-xxxxx

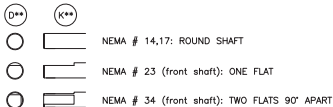
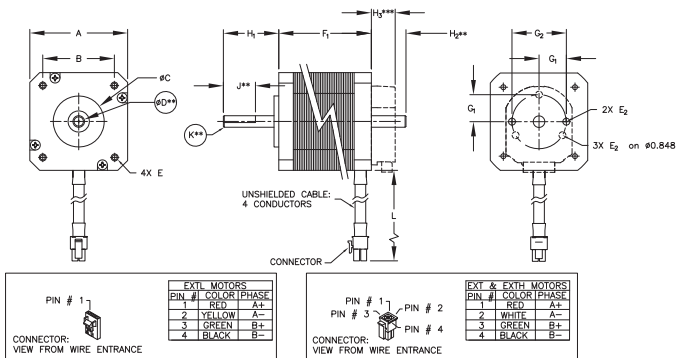

NOTE: MTRH and MTRAC information is on later pages

STP-MTR-xxxxxW

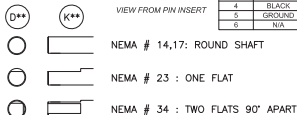
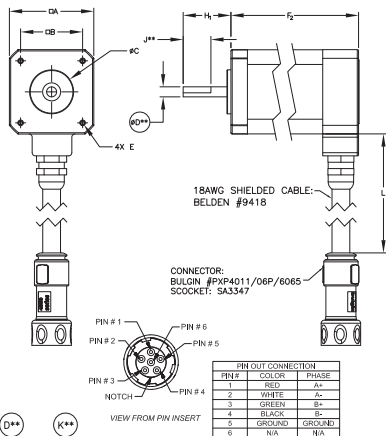

STP-MTR-34xxx

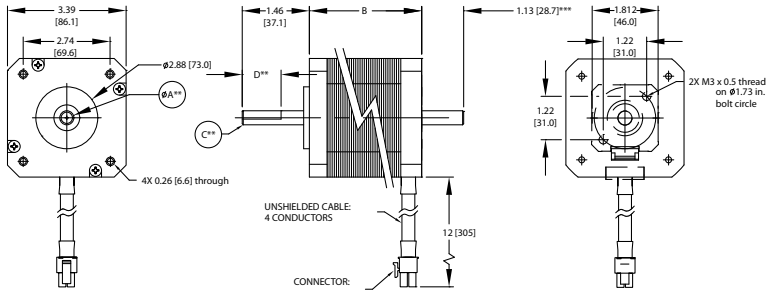

PIN # 1



CONNECTOR:
VIEW FROM WIRE ENTRANCE

EXTL MOTORS		
PIN #	COLOR	PHASE
1	RED	A+
2	YELLOW	A-
3	GREEN	B+
4	BLACK	B-

PIN # 1



CONNECTOR:
VIEW FROM WIRE ENTRANCE

EXT & EXTH MOTORS		
PIN #	COLOR	PHASE
1	RED	A+
2	WHITE	A-
3	GREEN	B+
4	BLACK	B-



NEMA # 34 (front shaft): TWO FLATS 90° APART

- ** Dimension A is the same for both front and rear shafts of dual-shaft motors.
- ** Dimensions C & D do NOT apply to rear shafts of dual-shaft motors (all rear shafts are round style).
- *** Dimension applies only to dual-shaft (D) motors.

SureStep™ Series Dimensions & Cabling – STP-MTR-x*** Step Motors								
Dimensions (in [mm])*	Low Torque Motors		High Torque Motors STP-MTR-x					
	STP-MTRL -14026x	STP-MTRL -14034x	STP-MTR -17040x	STP-MTR -17048x	STP-MTR -17060x	STP-MTR -23055x	STP-MTR -23079x	STP-MTR -34066x
A	1.39 [35.3]		1.67 [42.3]			2.25 [57.2]		3.39 [86.1]
B	1.02 [25.9]		1.22 [31.0]			1.86 [47.2]		2.74 [69.6]
C	Ø 0.87 [22.1]					Ø 1.50 [38.1]		Ø 2.88 [73.0]
D**	Ø 0.20 [5.0]					Ø 0.25 [6.4]		Ø 0.50 [12.7]
E	4-40 thread 0.15 [3.8] min depth		M3 x 0.5 thread 0.15 [3.8] min depth			Ø 0.20 [5.1] through		Ø 0.26 [6.6] through
E2	M2.5 X 0.45 thread				M2 x 0.4 thread	4-40		M2.5 x 0.45 thread
E3	n/a							M3 x 0.5 thread on a 1.73 in. bolt circle
F1**	1.02 [25.9]	1.34 [34.0]	1.58 [40.1]	1.89 [48.0]	2.34 [59.5]	2.22 [56.4]	3.10 [78.7]	2.64 [67.1]
F2**	n/a		1.90 [48.3]	2.24 [56.9]	2.67 [67.8]	2.33 [59.1]	3.19 [81.0]	2.64 [67.1]
G1	0.375 [9.5]				0.411 [10.4]	0.906 [23]		n/a
G2	0.75 [19.1]				n/a	1.812 [46]		
G3	n/a							1.22 [31]
H1	0.60 [15.2]		0.94 [24.0]			0.81 [20.6]		1.46 [37.1]
H2**	0.51 [13.0]		0.51 [13]			0.51 [13]		1.13 [28.7]
H3**	0.40 [10.1]							n/a
J**	n/a					0.59 [15.0]		0.98 [25.0]
K**	n/a					0.23 [5.8]		0.45 [11.4]
L	12 [305]							
Conductor	(4) #26 AWG		(4) #20 AWG					
Connector	TE # 103653-3		Molex # 43025-0400 PXP4010/06S/6065 (for W motors)					
Pin	TE # 1-104505-3 (LOOSE)		Molex # 43030-0007 Socket: SA3347 (for W motors)					

* mm dimensions are for reference purposes only.

** Dimension D (shaft diameter) is the same for both front and rear shafts of dual-shaft and encoder motors. Dimension H₂ applies only to dual-shaft (D) and encoder (E) motors. Dimensions J & K do NOT apply to rear shafts of dual-shaft or encoder motors (all rear shafts are round style). Dimension H₃ applies only to "E" models with the encoder pre-mounted. Dimension F₂ applies to "W" models only.

*** Higher Torque STP-MTRH and high bus voltage STP-MTRAC motors are shown in a separate table.

Typical Dimension & Cable Diagram for STP-MTRH

STP-MTRH-23079x

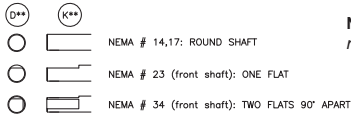
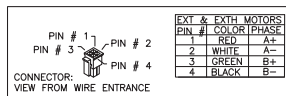
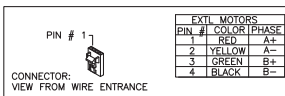
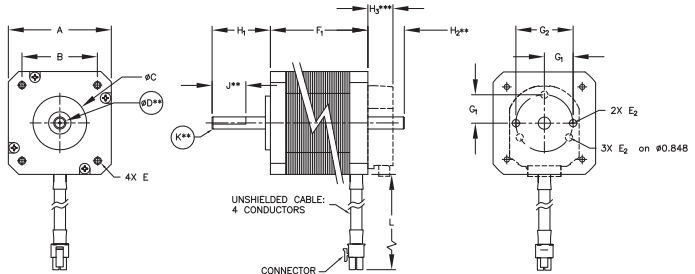

NOTE: NEMA 34 motor on the next page.

STP-MTRH-xxxxxW

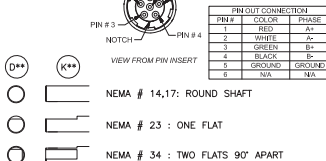
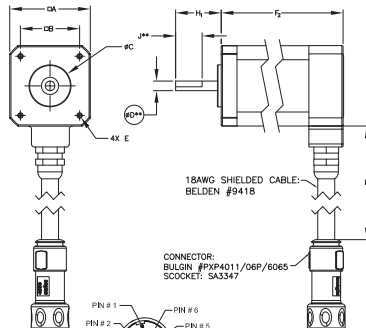

NOTE: STP-MTRAC information is on later pages

STP-MTRH-34xxx

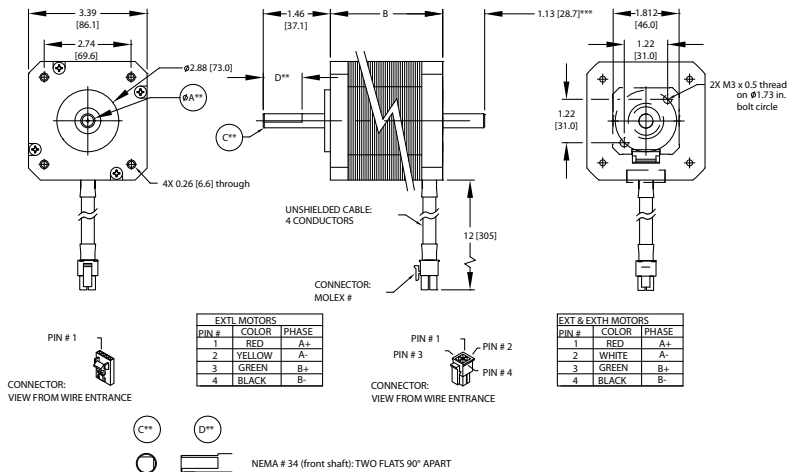

- ** Dimension A is the same for both front and rear shafts of dual-shaft motors.
- ** Dimensions C & D do NOT apply to rear shafts of dual-shaft motors (all rear shafts are round style).
- *** Dimension applies only to dual-shaft (D) motors.

SureStep™ Series Dimensions & Cabling – STP-MTRH-x*** Step Motors

Dimensions (in [mm])*	Higher Torque Motors STP-MTRH-x			
	STP-MTRH- 23079x	STP-MTRH- 34066x	STP-MTRH- 34097x	STP-MTRH- 34127x
A	2.25 [57.2]	3.39 [86.1]		
B	1.86 [47.2]	2.74 [69.6]		
C	Ø 1.50 [38.1]	Ø 2.88 [73.0]		
D**	Ø 0.25 [6.4]	Ø 0.50 [12.7]		
E	Ø 0.20 [5.1] through	Ø 0.26 [6.6] through		
E²	4-40	M2.5 x 0.45 thread		
E³	n/a	M3 x 0.5 thread on a 1.73 in. bolt circle		
F₁**	3.10 [78.7]	2.64 [67.1]	3.82 [97.1]	5.00 [127.0]
F₂**	3.19 [81.0]	2.74 [67.1]	3.82 [97.1]	5.00 [127.0]
G¹	0.906 [23]	n/a		
G²	1.812 [46]			
G³	n/a	1.22 [31]		
H₁	0.81 [20.6]	1.46 [37.1]		
H₂**	0.51 [13]	1.13 [28.7]		
H₃**	0.40 [10.2]	n/a		
J**	0.59 [15.0]	0.98 [25.0]		
K**	0.23 [5.8]	0.45 [11.4]		
L	12 [305]			
Conductor	(4) #18 AWG (5) #18 AWG (for W motors)			
Connector	Molex # 39-01-3042 PXP4010/06S/6065 (for W motors)			
Pin	Molex # 39-00-0039 Socket: SA3347 (for W motors)			

* mm dimensions are for reference purposes only.

** Dimension D (shaft diameter) is the same for both front and rear shafts of dual-shaft and encoder motors. Dimension H₂ applies only to dual-shaft (D) and encoder (E) motors. Dimensions J & K do NOT apply to rear shafts of dual-shaft and encoder motors (all rear shafts are round style). Dimension H₃ applies only to "E" models with the encoder pre-mounted. Dimension F₂ applies to "W" models only.

*** High bus voltage STP-MTRAC motors are shown in a separate table.

Typical Dimension & Cable Diagram for STP-MTRAC

STP-MTRAC-23xxx

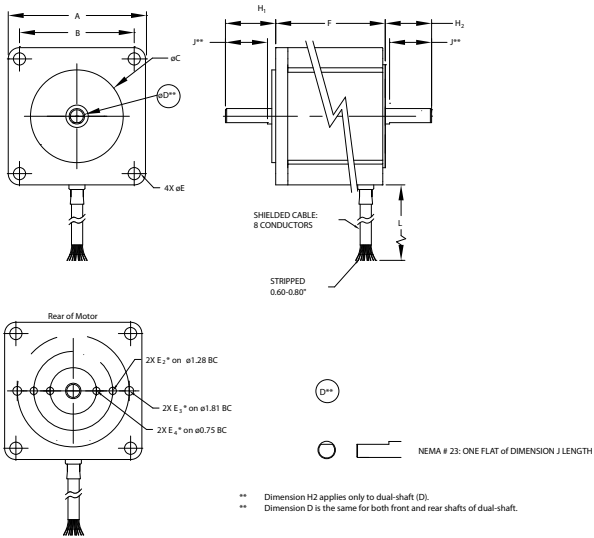

STP-MTRAC-34xxx

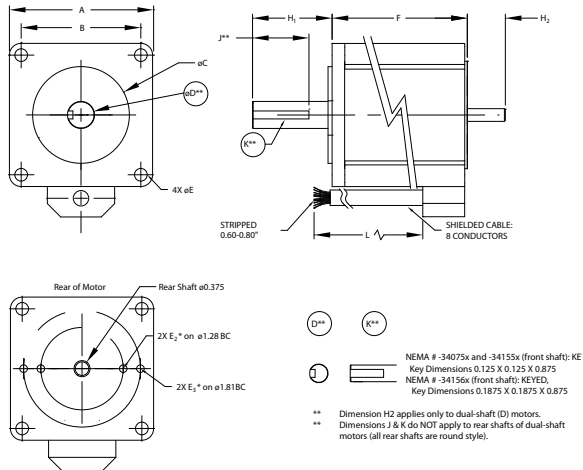

SureStep™ Series Dimensions & Cabling – STP-MTRAC-x Step Motors						
Dimensions (in [mm])*	High Bus Voltage Motors					
	STP-MTRAC -23044x	STP-MTRAC -23055x	STP-MTRAC -23078x	STP-MTRAC -34075x	STP-MTRAC -34115x	STP-MTRAC -34156x
A	2.25 [57.15]	2.25 [57.15]	2.25 [57.15]	3.39 [86.1]	3.39 [86.1]	3.39 [86.1]
B	1.86 [47.24]	1.86 [47.24]	1.86 [47.24]	2.74 [69.6]	2.74 [69.6]	2.74 [69.6]
C	1.50 [38.1]	1.50 [38.1]	1.50 [38.1]	2.87 [72.9]	2.87 [72.9]	2.87 [72.9]
D**	0.25 [6.35]	0.25 [6.35]	0.25 [6.35]	0.5 [12.7]	0.5 [12.7]	0.625 [15.9]
E	0.2 [5.08]	0.2 [5.08]	0.2 [5.08]	0.22 [5.59]	0.26 [6.6]	0.22 [5.59]
E₂***	2-56 thru	2-56 thru	2-56 thru	2-56 UNC Tap 0.2 Deep	2-56 UNC Tap 0.2 Deep	2-56 UNC Tap 0.2 Deep
E₃***	4-40 UNC x 0.2 Deep	4-40 UNC x 0.2 Deep	4-40 UNC x 0.2 Deep	4-40 UNC Tap 0.2 Deep	4-40 UNC Tap 0.2 Deep	4-40 UNC Tap 0.2 Deep
E₄***	2-56 UNC Tap 0.2 Deep	2-56 UNC Tap 0.2 Deep	2-56 UNC Tap 0.2 Deep	–	–	–
F	1.71 [43.43]	2.16 [54.86]	3.05 [77.47]	2.95 [74.93]	4.52 [114.81]	6.14 [155.96]
H₁	0.81 [20.57]	0.81 [20.57]	0.81 [20.57]	1.25 [31.75]	1.25 [31.75]	1.25 [31.75]
H₂***	0.63 [16.0]	0.63 [16.0]	0.63 [16.0]	1.12 [28.45]	1.12 [28.45]	1.12 [28.45]
J	0.60 [15.24]	0.60 [15.24]	0.60 [15.24]	0.87 [22.1]	0.87 [22.1]	0.87 [22.1]
L	120 [3048]	120 [3048]	120 [3048]	120 [3048]	120 [3048]	120 [3048]
* mm dimensions are for reference purposes only.						
** Dimension D (shaft diameter) is the same for both front and rear shafts of NEMA 23 dual-shaft motors. See diagrams for NEMA 34.						
*** Dimension applies only to dual-shaft (D) motors.						

Typical Dimension & Cable Diagram for STP-MTRAC(H)-42x

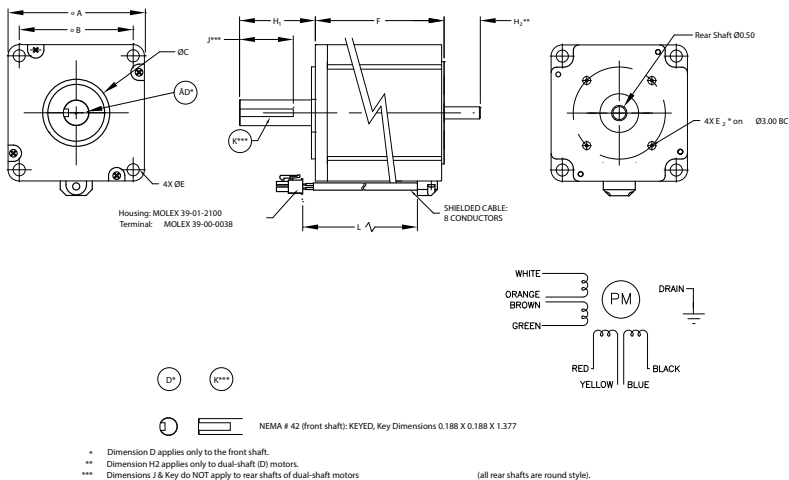

SureStep™ Series Dimensions & Cabling – STP-MTRAC(H)-42x Step Motors						
Dimensions (in [mm])*	Higher Bus Voltage Motors					
	STP-MTRAC(H)-42100	STP-MTRAC(H)-42151	STP-MTRAC(H)-42202	STP-MTRAC(H)-42100D	STP-MTRAC(H)-42151D	STP-MTRAC(H)-42202D
A	4.33 [110]	4.33 [110]	4.33 [110]	4.33 [110]	4.33 [110]	4.33 [110]
B	3.50 [88.9]	3.50 [88.9]	3.50 [88.9]	3.50 [88.9]	3.50 [88.9]	3.50 [88.9]
C	2.19 [55.6]	2.19 [55.6]	2.19 [55.6]	2.19 [55.6]	2.19 [55.6]	2.19 [55.6]
D**	0.75 [19.05]	0.75 [19.05]	0.75 [19.05]	0.75 [19.05]	0.75 [19.05]	0.75 [19.05]
E	0.327 [8.31]	0.327 [8.31]	0.327 [8.31]	0.327 [8.31]	0.327 [8.31]	0.327 [8.31]
E₂	n/a	n/a	n/a	4-40 UNC Tap 0.2 Deep	4-40 UNC Tap 0.2 Deep	4-40 UNC Tap 0.2 Deep
F	3.88	5.94	7.91	3.88***	5.94***	7.91***
H₁	2.19 [55.6]	2.19 [55.6]	2.19 [55.6]	2.19 [55.6]	2.19 [55.6]	2.19 [55.6]
H₂	n/a	n/a	n/a	1.12 [28.4]	1.12 [28.4]	1.12 [28.4]
J**	1.37 [34.8]	1.37 [34.8]	1.37 [34.8]	1.37 [34.8]	1.37 [34.8]	1.37 [34.8]
L	12 [305]					

* mm dimensions are for reference purposes only.
** Dimension D (shaft diameter), J, and Key do not apply to rear shafts of dual-shaft motors.
*** For encoder mounting the required STP-MTRA-42ENC will add 0.13 inches [3.2 mm] to the length of the motor.

Torque vs. Speed Charts

STP-MTR-14xxx(D) NEMA 14 Step Motors

STP-MTR-14026(x) Torque vs Speed (1.8° step motor; 1/2 stepping, RMS phase current)

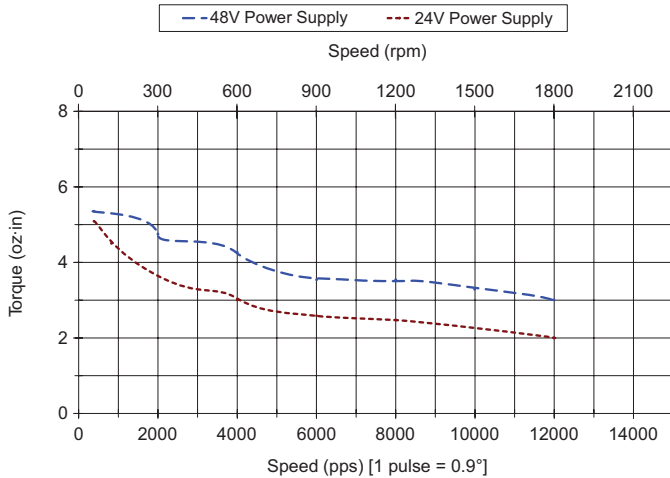

STP-MTR-14034(x) Torque vs Speed (1.8° step motor; 1/2 stepping, RMS phase current)

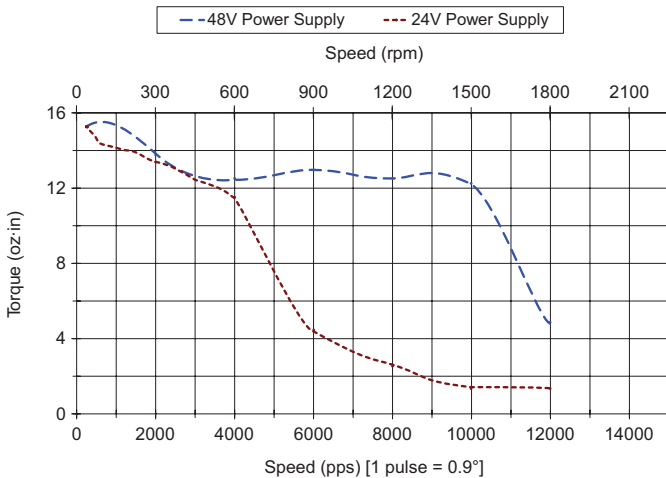

STP-MTR-17xxx(D) NEMA 17 Step Motors

Note: "W" series motors have 5% less running torque than other models.

STP-MTR-17040x Torque vs Speed (1.8° step motor; 1/2 stepping, RMS phase current)

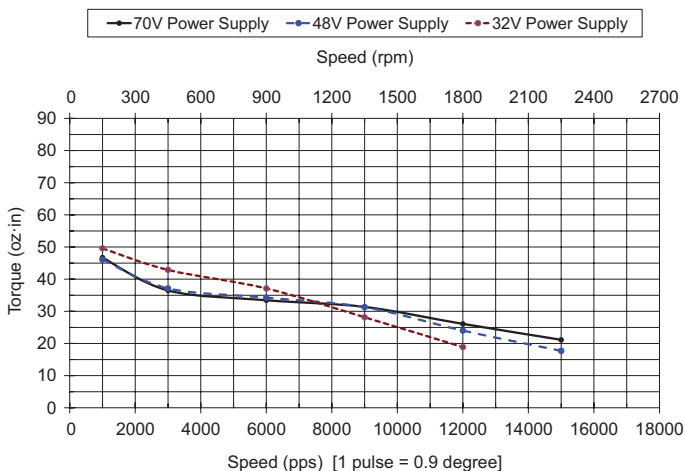

STP-MTR-17048x Torque vs Speed (1.8° step motor; 1/2 stepping, RMS phase current)

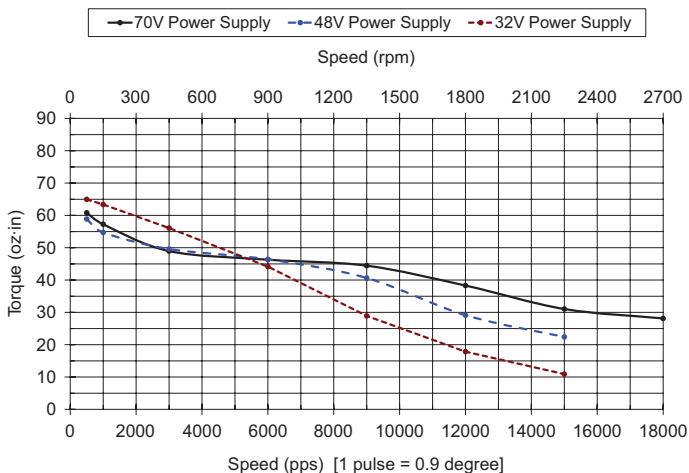

Torque vs. Speed Charts (continued)

Note: "W" series motors have 5% less running torque than other models.

STP-MTR-17xxx(D) NEMA 17 Step Motors (continued)

STP-MTR-17060x Torque vs Speed (1.8° step motor; 1/2 stepping, RMS phase current)

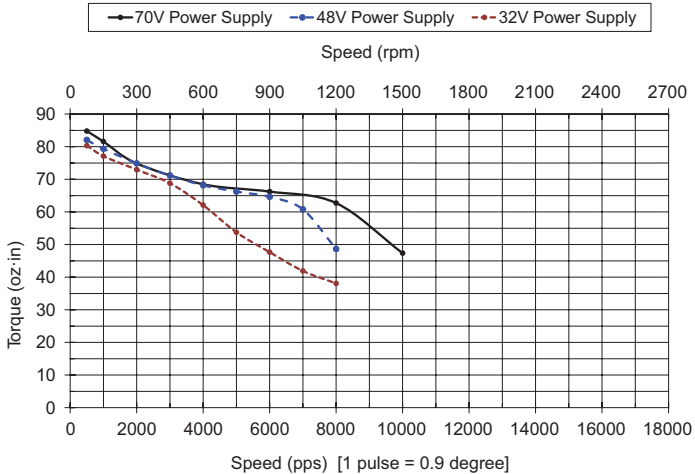

STP-MTR(H)-23xxx(D) NEMA 23 Step Motors

STP-MTR-23055x Torque vs Speed (1.8° step motor; 1/2 stepping, RMS phase current)

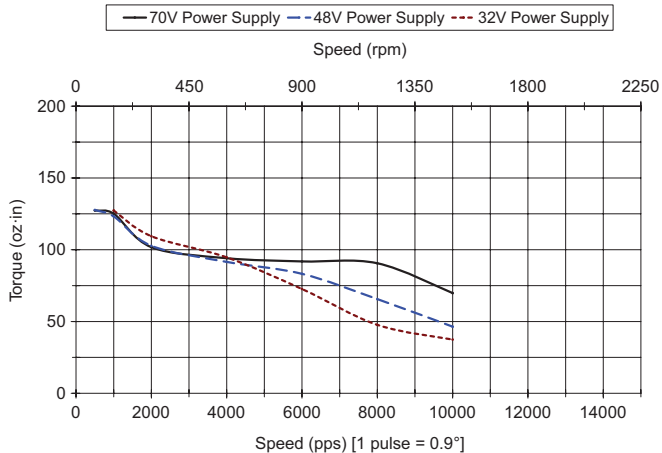

Torque vs. Speed Charts (continued)

Note: "W" series motors have 5% less running torque than other models.

STP-MTR(H)-23xxx(D) NEMA 23 Step Motors (continued)

STP-MTR-23079x Torque vs Speed (1.8° step motor; 1/2 stepping, RMS phase current)

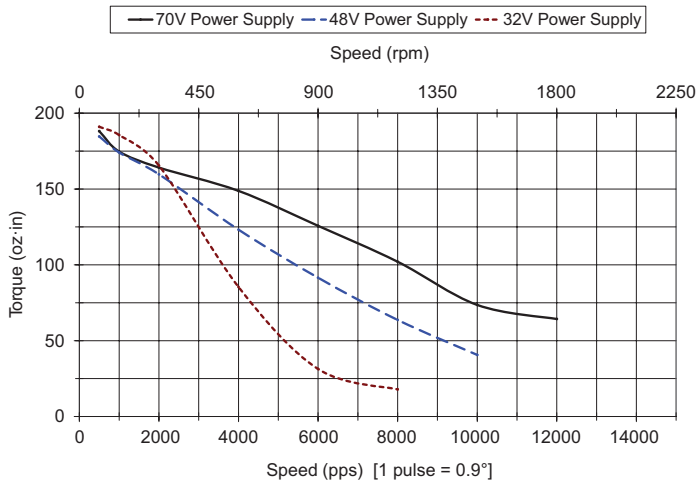

STP-MTRH-23079x Torque vs Speed (1.8° step motor; 1/2 stepping, RMS phase current)

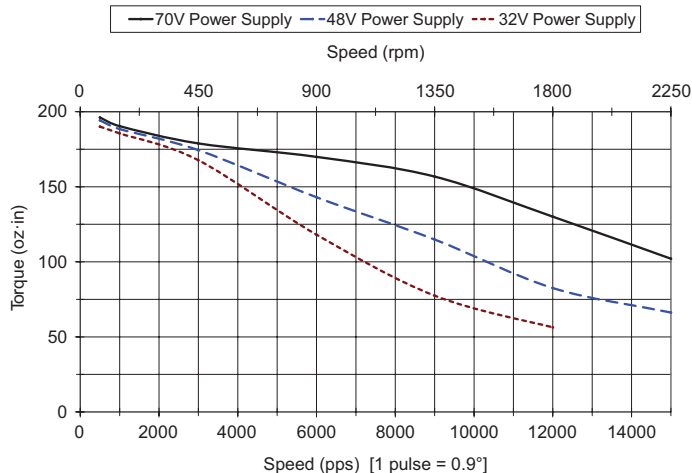

Torque vs. Speed Charts (continued)

Note: "W" series motors have 5% less running torque than other models.

STP-MTR(H)-34xx(D) NEMA 34 Step Motors

STP-MTR-34066x Torque vs Speed (1.8° step motor; 1/2 stepping, RMS phase current)

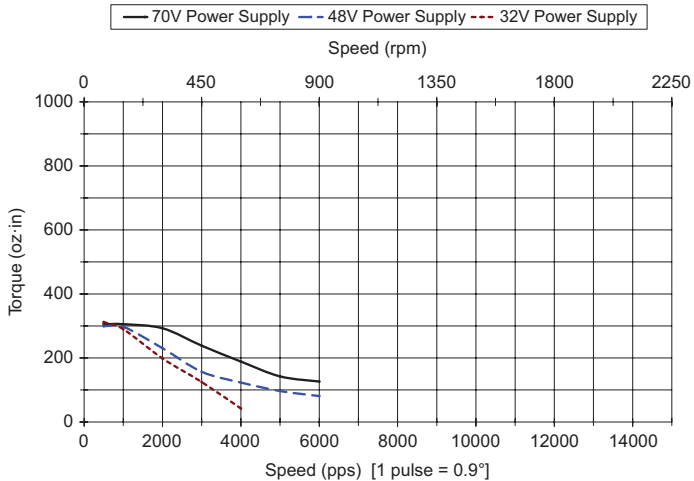

STP-MTRH-34066x Torque vs Speed (1.8° motor; 1/2 stepping, RMS phase current)

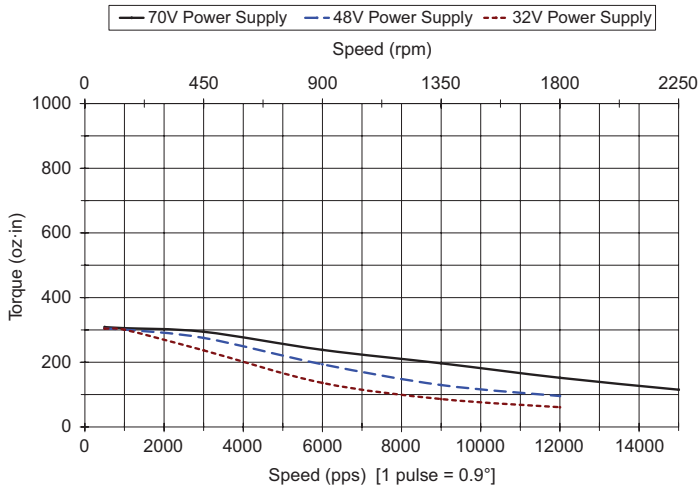

Torque vs. Speed Charts (continued)

Note: "W" series motors have 5% less running torque than other models.

STP-MTR(H)-34xxx(D) NEMA 34 Step Motors (continued)

STP-MTRH-34097x Torque vs Speed (1.8° step motor; 1/2 stepping, RMS phase current)

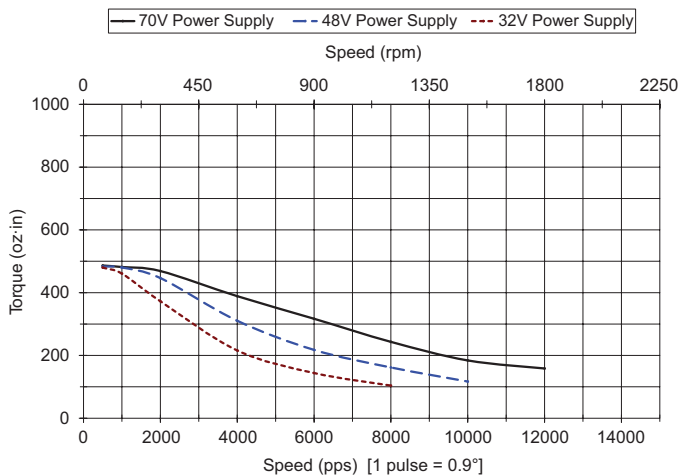

STP-MTRH-34127x Torque vs Speed (1.8° step motor; 1/2 stepping, RMS phase current)

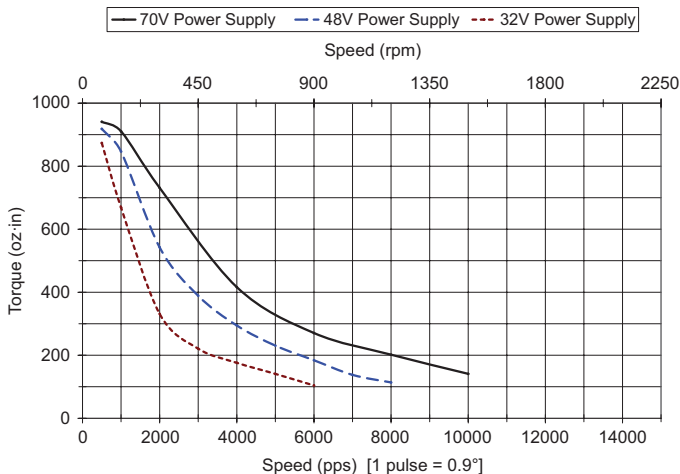

Torque vs. Speed Charts (continued)

STP-MTRAC-23xxxx Torque vs Speed @ 340VDC bus
(1.8° step motor; 1/2 stepping)

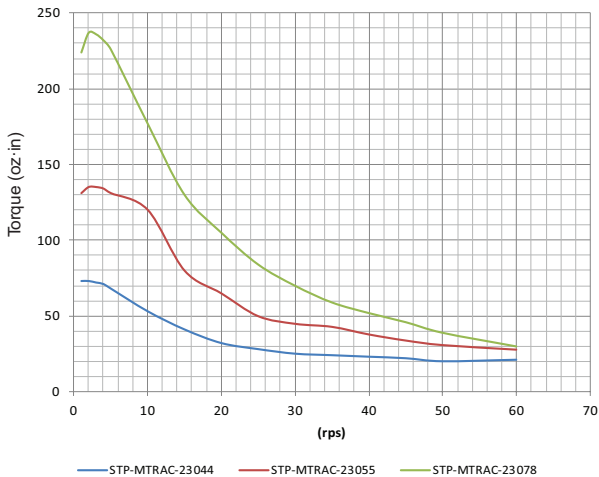

STP-MTRAC-34xxxx Torque vs Speed @ 340VDC bus
(1.8° step motor; 1/2 stepping)

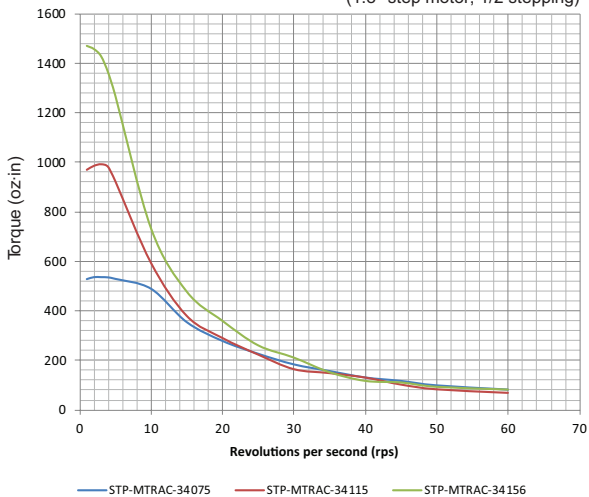

For NEMA 42 charts:
 "S" = Bipolar Series
 "P" = Bipolar Parallel

Torque vs. Speed Charts (continued)

STP-MTRAC-42100x 24/48 VDC

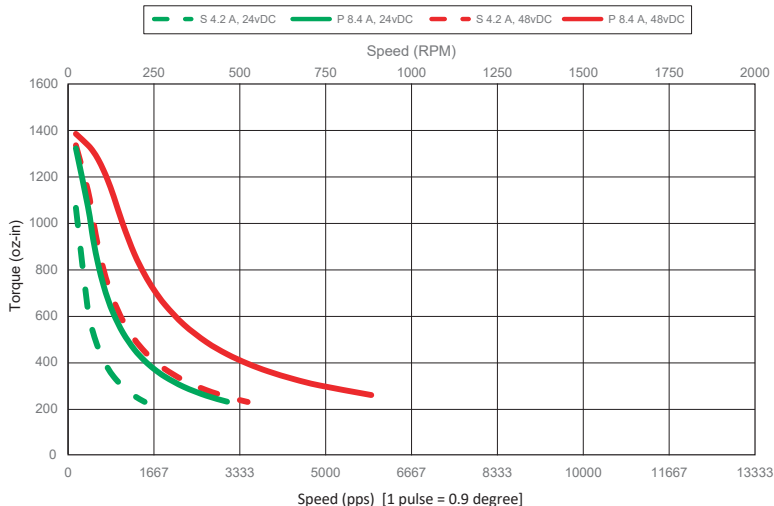

STP-MTRAC-42100x 72/160VDC

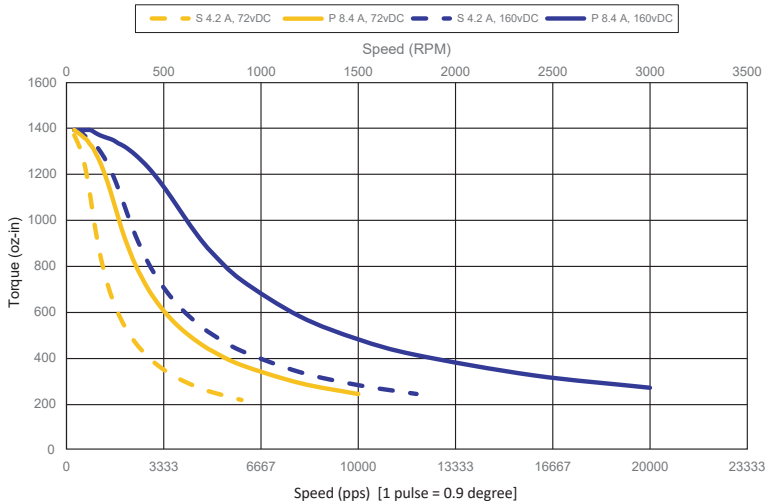

Torque vs. Speed Charts (continued)

For NEMA 42 charts:
 "S" = Bipolar Series
 "P" = Bipolar Parallel

STP-MTRAC-42151x 24/48 VDC

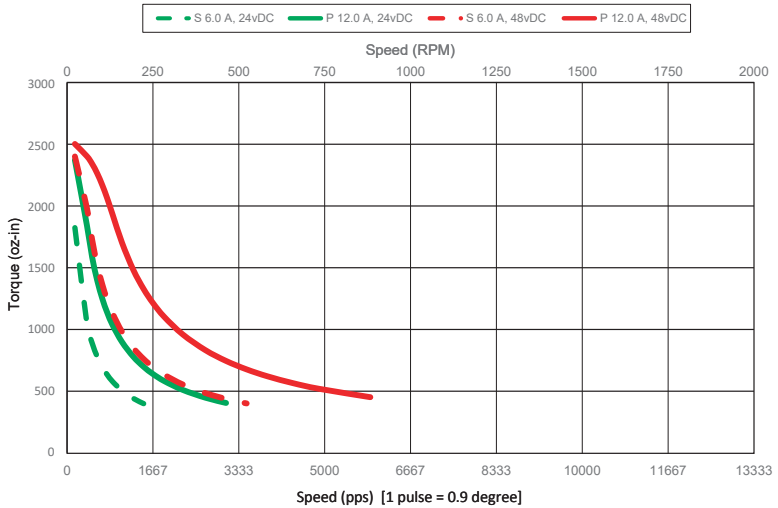

STP-MTRAC-42151x 72/160VDC

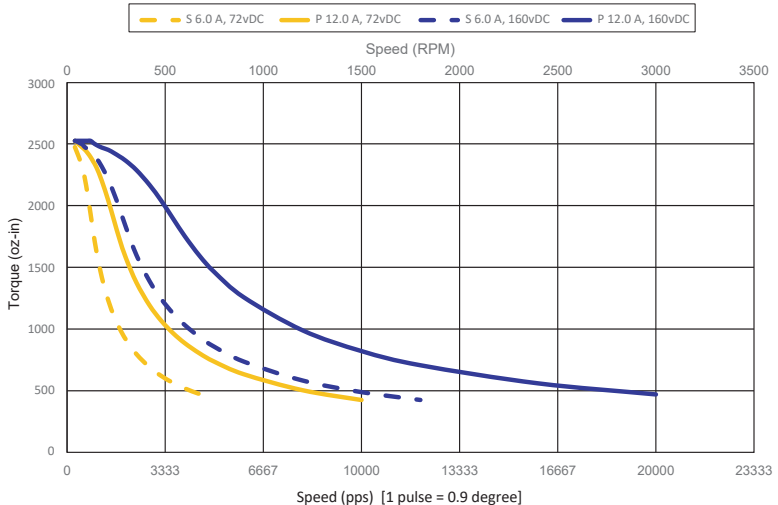

For NEMA 42 charts:
 "S" = Bipolar Series
 "P" = Bipolar Parallel

Torque vs. Speed Charts (continued)

STP-MTRAC-42202x 24/48 VDC

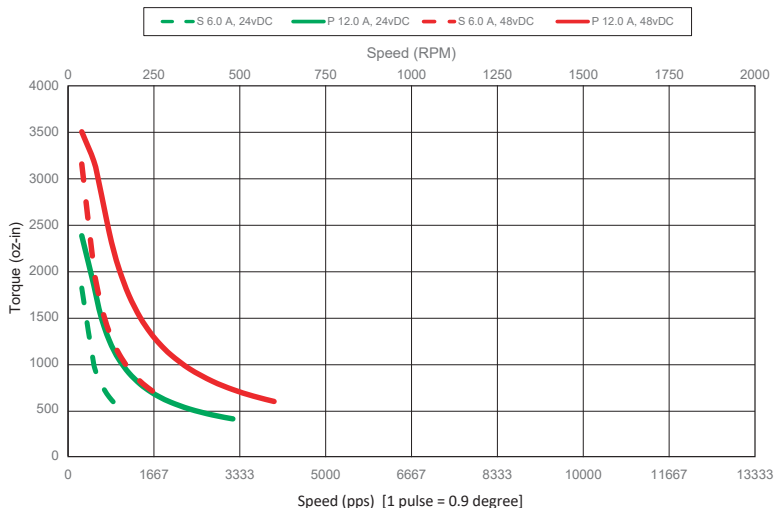

STP-MTRAC-42202x 72/160VDC

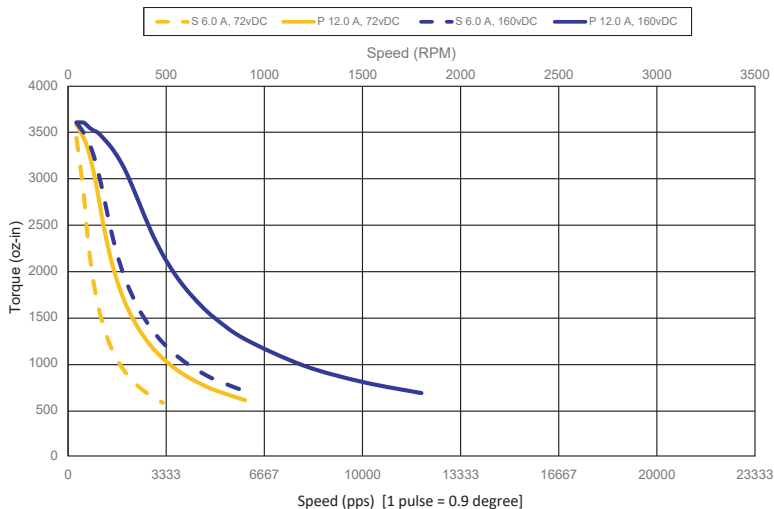

Torque vs. Speed Charts (continued)

For NEMA 42 charts:
 "S" = Bipolar Series
 "P" = Bipolar Parallel

STP-MTRACH-42100x 24/48 VDC

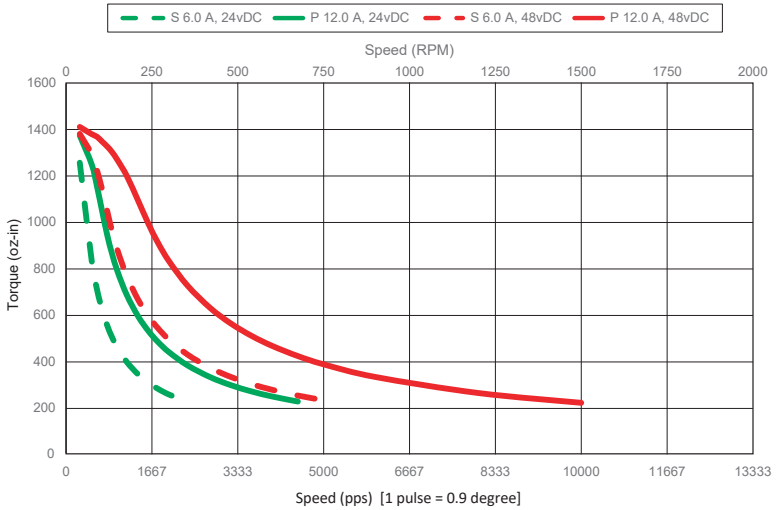

STP-MTRACH-42100x 72/160VDC

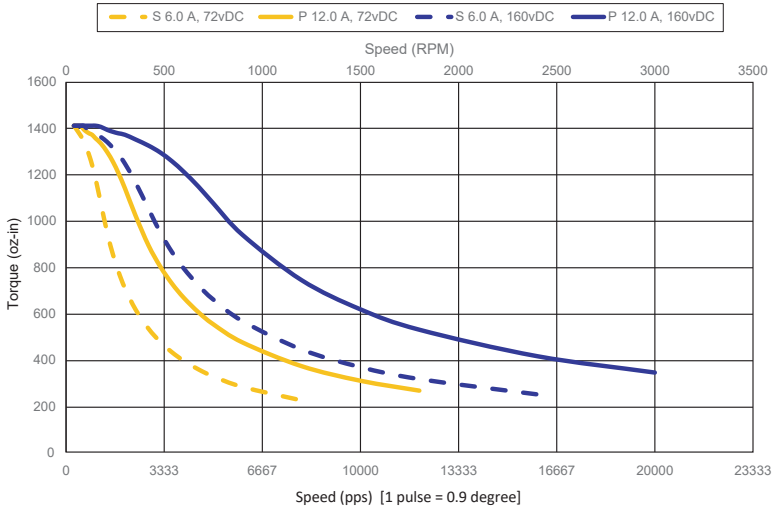

For NEMA 42 charts:
 "S" = Bipolar Series
 "P" = Bipolar Parallel

Torque vs. Speed Charts (continued)

STP-MTRACH-42151x 24/48 VDC

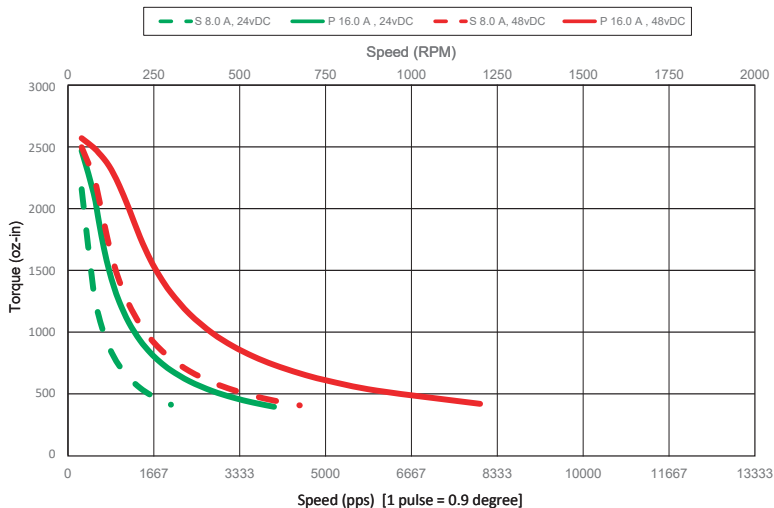

STP-MTRACH-42151x 72/160VDC

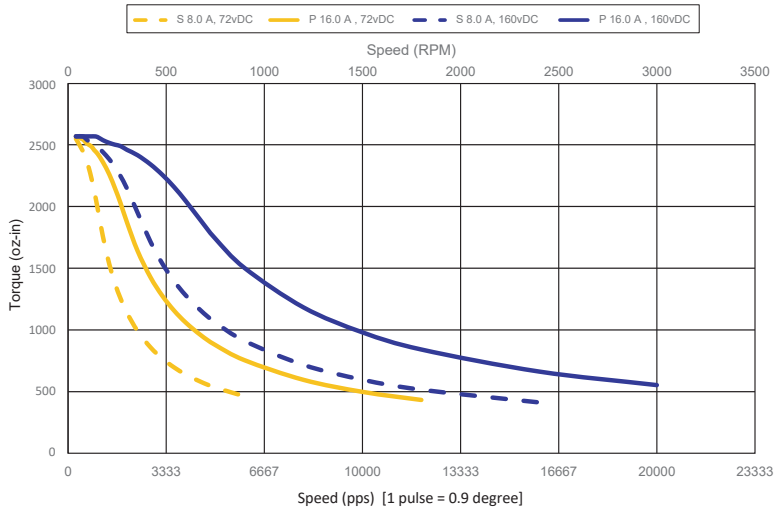

Torque vs. Speed Charts (continued)

For NEMA 42 charts:
 "S" = Bipolar Series
 "P" = Bipolar Parallel

STP-MTRACH-42202x 24/48 VDC

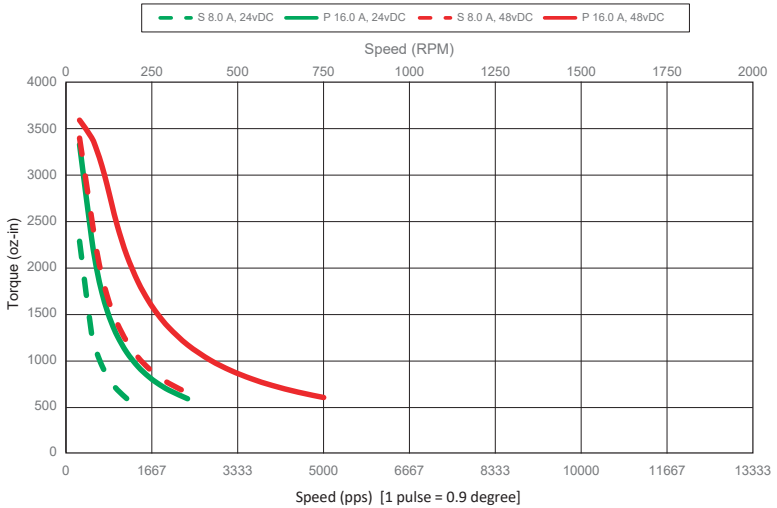

STP-MTRACH-42202x 72/160VDC

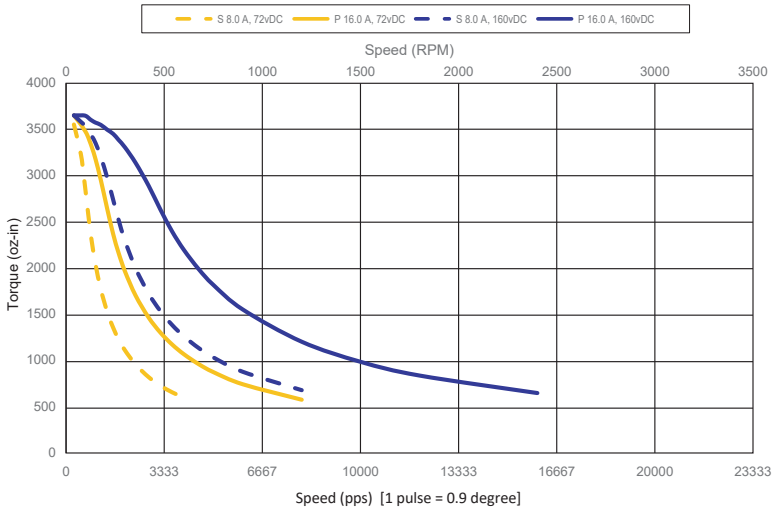

BLANK
PAGE