



8

In This Chapter...

Features	8-2
Design and Installation Tips	8-3
Model Number Explanation	8-3
Specifications	8-4
Power Supply and Step Motor Drive.	8-8
Mounting the Motor	8-8
Journal Mounting	8-8
Connecting the Motor	8-10
Extension Cable Wiring Diagrams	8-10
Motor Dimensions and Cabling	8-12
Thrust vs. Speed Charts	8-16

Features

- Stepper Linear Actuators available in NEMA 17 and NEMA 23 motor frame sizes.
- Square frame style produces high torque and achieves best torque to volume ratio.
- Linear forces up to 193lbs
- Linear speeds up to 19 in/sec
- Available in single-shaft and dual-shaft configurations.
- Lead Screws are cold-finished stainless steel (SUS303Cu).
- Nuts are PTFE-infused polymer (TECFORM AD AF) and require no lubrication.
- Dual shaft models are encoder ready (pretapped holes ready for modular encoder mounting).
- Dual shaft models have machined journals and grooves for bearing and retaining ring mounting.
- Three lead screw lengths of 6, 9, and 12 inches
- Nine different lead pitches from 1.25 mm/rev to 1 inch/rev
- Optional 6, 10, or 20 foot extension cable with locking connector available.
- Replacement triangular nuts and round nuts available.

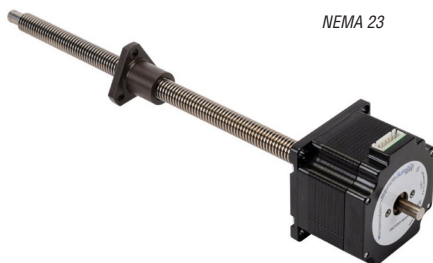
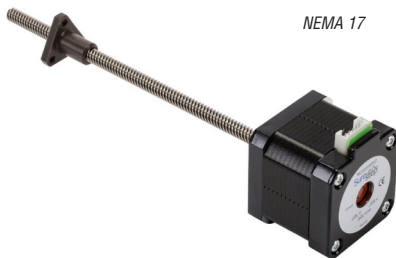

Design and Installation Tips

Allow sufficient time to accelerate the load and size the step motor with a 100% torque safety factor (i.e.: design the system using a maximum of 50% of the motor's torque). DO NOT disassemble lead screw step motors, as motor performance will be reduced and the warranty will be voided. DO NOT connect or disconnect the step motor during operation.

The motor can be mounted in any orientation (horizontal or vertical). There can be slight backlash when mounting in a horizontal application. Most vertical applications will not be subjected to any noticeable backlash. In horizontal applications do not apply any appreciable overhung load to the screw. If the load causes more than 0.0025" of deflection per inch of lead screw, support the end of the screw with a sleeve, bushing or bearing. In vertical applications securing the end of the screw may not be needed. Mount it to a surface with good thermal conductivity, such as steel or aluminum, to allow heat dissipation.

In general, the higher the current into a step motor the higher the torque, especially at lower speeds. The higher the voltage to the step motor, the higher the torque at higher speeds. Losses come in to play here, too. The higher you run the current on the motors, the higher your losses are going to be, and the hotter your motors are going to get. For this reason, Automation Direct specs current for motors at the RMS value. This is the value on the motor's label and specification table. This guarantees a very long life for the motor. Multiplying the motor's RMS phase current by 1.2 gives a good balance of rotary torque (linear thrust of the actuator) vs loss. This value should then be used to set the drive's peak phase current. Note that the whole speed thrust curve won't be shifted up, only the low speed flat part before the torque starts dropping. The curve can drop for many reasons, but typically it's due to not having enough voltage to push the desired current into the windings, so increasing the voltage is what gives you a boost there, not making more current available.

Model Number Explanation

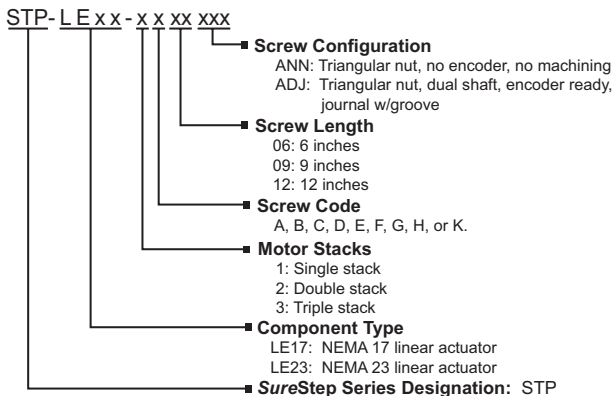

Specifications

The tables below reference the specifications for all the SureStep Linear Actuators sold by AutomationDirect. Click the location link to go directly to the spec table.

Model Number	Lead (per rev)	Nominal Thrust (@150RPM)	Motor Weight (lbs)	Specifications Location
STP-LE17-2A06ANN	0.25"	45lbs	0.7	Table 1, STP-LE17-2Axxxx
STP-LE17-2A09ANN			0.8	
STP-LE17-2A12ANN			0.9	
STP-LE17-2A06ADJ			0.7	
STP-LE17-2A09ADJ			0.8	
STP-LE17-2A12ADJ			0.9	
STP-LE17-3A06ANN	0.25"	69lbs	0.9	Table 1, STP-LE17-3Axxxx
STP-LE17-3A09ANN			1.1	
STP-LE17-3A12ANN			1.3	
STP-LE17-3A06ADJ			0.9	
STP-LE17-3A09ADJ			1.1	
STP-LE17-3A12ADJ			1.3	
STP-LE17-3B06ANN	0.5"	38lbs	0.9	Table 1, STP-LE17-3Bxxxx
STP-LE17-3B09ANN			1.1	
STP-LE17-3B12ANN			1.3	
STP-LE17-3B06ADJ			0.9	
STP-LE17-3B09ADJ			1.1	
STP-LE17-3B12ADJ			1.3	
STP-LE17-2C06ANN	3mm	73lbs	0.7	Table 1, STP-LE17-2Cxxxx
STP-LE17-2C09ANN			0.8	
STP-LE17-2C12ANN			0.9	
STP-LE17-2C06ADJ			0.7	
STP-LE17-2C09ADJ			0.8	
STP-LE17-2C12ADJ			0.9	
STP-LE17-2D06ANN	1.25 mm	87lbs	0.8	Table 1, STP-LE17-2Dxxxx
STP-LE17-2D09ANN			0.9	
STP-LE17-2D12ANN			1.0	
STP-LE17-2D06ADJ			0.8	
STP-LE17-2D09ADJ			0.9	
STP-LE17-2D12ADJ			1.0	

Model Number	Lead (per rev)	Nominal Thrust (@150RPM)	Motor Weight (lbs)	Specifications Location
STP-LE17-3E06ANN	8mm	55lbs	1.0	Table 1, STP-LE17-3Exxyy
STP-LE17-3E09ANN			1.2	
STP-LE17-3E12ANN			1.4	
STP-LE17-3E06ADJ			1.0	
STP-LE17-3E09ADJ			1.2	
STP-LE17-3E12ADJ			1.4	
STP-LE23-1F06ANN	10.5 mm	63lbs	1.4	Table 2, STP-LE23-1Fxyyy
STP-LE23-1F09ANN			1.6	
STP-LE23-1F12ANN			1.8	
STP-LE23-1F06ADJ			1.4	
STP-LE23-1F09ADJ			1.6	
STP-LE23-1F12ADJ			1.8	
STP-LE23-1G06ANN	2mm	137lbs	1.4	Table 2, STP-LE23-1Gxyyy
STP-LE23-1G09ANN			1.7	
STP-LE23-1G12ANN			2.0	
STP-LE23-1G06ADJ			1.4	
STP-LE23-1G09ADJ			1.7	
STP-LE23-1G12ADJ			2.0	
STP-LE23-1H06ANN	6mm	87lbs	1.4	Table 2, STP-LE23-1Hxyyy
STP-LE23-1H09ANN			1.7	
STP-LE23-1H12ANN			2.0	
STP-LE23-1H06ADJ			1.4	
STP-LE23-1H09ADJ			1.7	
STP-LE23-1H12ADJ			2.0	
STP-LE23-3H06ANN	6mm	193lbs	2.7	Table 2, STP-LE23-3Hxyyy
STP-LE23-3H09ANN			3.0	
STP-LE23-3H12ANN			3.3	
STP-LE23-3H06ADJ			2.7	
STP-LE23-3H09ADJ			3.0	
STP-LE23-3H12ADJ			3.3	
STP-LE23-3K06ANN	1"	62lbs	2.7	Table 2, STP-LE23-3Kxyyy
STP-LE23-3K09ANN			3.0	
STP-LE23-3K12ANN			3.3	
STP-LE23-3K06ADJ			2.7	
STP-LE23-3K09ADJ			3.0	
STP-LE23-3K12ADJ			3.3	

Table 1: NEMA 17 Linear Actuator Specifications

SureStep™ Series Specifications – Linear Actuator Stepping Motors						
Linear Actuator Motors	STP-LE17-2Axyyy	STP-LE17-2Cxyyy	STP-LE17-2Dxyyy	STP-LE17-3Axyyy	STP-LE17-3Bxyyy	STP-LE17-3Exyyy
NEMA	17					
Phases	2					
Rated Current	2A					
Phase Resistance	1.04 Ω ± 10% (@20°C)			1.25 Ω ± 15% (@20°C)		
Phase Inductance	2.5 mH ± 20% (1kHz 1V rms)			2.8 mH ± 20% (1kHz 1V rms)		
Rotor Inertia	57 g·cm ²			82 g·cm ²		
Rotational Shaft Holding Torque	0.46 N·m (65.14 oz-in)			0.63 N·m (89.21 oz-in)		
No. of Motor Stacks	2			3		
Motor Length	39.8 mm			48.3 mm		
Screw Material	SUS303Cu (cold-finished stainless steel)					
Nut Material	TECAFORM AD AF (PTFE-infused polymer)					
Lead	0.25"/rev	3mm/rev	1.25 mm/ rev	0.25"/rev	0.5"/rev	8mm/rev
Linear Travel/Step (1.8°)	0.00125 in/step	0.015 mm/ step	0.00625 mm/step	0.00125 in/step	0.0025 in/ step	0.04 mm/step
Linear Speed ¹ (@150rpm)	0.6250 in/sec	7.5 mm/sec	3.125 mm/sec	0.625 in/sec	1.25 in/sec	20 mm/sec
Thrust (@150rpm)	45lbs	73lbs	87lbs	69lbs	38lbs	55lbs
Load Limit (lbs) ²	75	75	80	75	75	80
Radial Deflection (Max) ³	6" lead screw: 0.015" 9" lead screw: 0.0225" 12" lead screw: 0.03"					
Ambient Operating Temperature	-20-50°C					
Insulation Class	B (130°C)					
Screw Diameter	0.25"	6.5 mm	8mm	0.25"	0.25"	8mm
Agency Approvals	CE					
1 To determine your linear speed as it relates to RPM use the following formula: Linear Speed = RPM x (Lead/60 sec)						
2 The load limit indicates max load before the nut lifespan is negatively impacted, not what the linear actuator can move.						
3 Calculated deflection is the deflection value measured at the end of the lead screw.						
Note: For dual-shaft motors (STP-LExx-xxxxADJ series) the sum of the front and rear torque loads, radial loads, and thrust loads must not exceed the applicable torque, radial and thrust load ratings of the motor.						

Table 2: NEMA 23 Linear Actuator Specifications

SureStep™ Series Specifications – Connectorized Bipolar Stepping Motors					
Linear Actuator Motors	STP-LE23-1Fxyyy	STP-LE23-1Hxyyy	STP-LE23-1Gxyyy	STP-LE23-3Kxyyy	STP-LE23-3Hxyyy
NEMA	23				
Phases	2				
Rated Current	2.1 A			3A	
Phase Resistance	1.6 Ω ± 10% (@20°C)			1.1 Ω ± 10% (@20°C)	
Phase Inductance	3.9 mH ± 20% (1kHz 1V rms)			5.0 mH ± 20% (1kHz 1V rms)	
Rotor Inertia	180 g·cm ²			460 g·cm ²	
Rotational Shaft Holding Torque	0.9 N·m (127.45 oz-in)			2.3 N·m (325.70 oz-in)	
No. of Motor Stacks	1			3	
Motor Length	45mm			79mm	
Screw Material	SUS303Cu (cold-finished stainless steel)				
Nut Material	TECAFORM AD AF (PTFE-infused polymer)				
Lead	10.5 mm/rev	6mm/rev	2mm/rev	1"/rev	6mm/rev
Linear Travel/Step (1.8°)	0.0525 mm/step	0.03 mm/step	0.01 mm/step	0.005 in/step	0.03 mm/step
Linear Speed ¹ (@150rpm) ²	26.25 mm/sec	15 mm/sec	5 mm/sec	2.5 in/sec	15 mm/sec
Thrust (@150rpm) ²	63lbs	87lbs	137lbs	62lbs	193lbs
Load Limit (lbs) ³	100	175	175	175	175
Radial Deflection (Max) ⁴	6" lead screw: 0.015" 9" lead screw: 0.0225" 12" lead screw: 0.03"				
Ambient Operating Temperature	-20-50°C				
Insulation Class	B (130°C)				
Screw Diameter	10mm	12mm	12mm	0.5"	12mm
Agency Approvals	CE				
<p>¹ To determine your linear speed as it relates to RPM use the following formula: <i>Linear Speed = RPM x (Lead/60 sec)</i></p> <p>² For STP-LE23-3KxxAyy and STP-LE23-3HxxAyy series motors, nominal speed and thrust values are provided for operation at 120rpm rather than 150rpm.</p> <p>³ The load limit indicates max load before the nut lifespan is negatively impacted, not what the linear actuator can move.</p> <p>⁴ Calculated deflection is the deflection value measured at the end of the lead screw.</p> <p>Note: For dual-shaft motors (STP-LExx-xxxxADJ series) the sum of the front and rear torque loads, radial loads, and thrust loads must not exceed the applicable torque, radial and thrust load ratings of the motor.</p>					

Power Supply and Step Motor Drive

An STP-PWR-xxxx linear power supply from AutomationDirect is the best choice to power AutomationDirect and other DC-input stepper drives. These power supplies were designed to work with the AutomationDirect SureStep™ STP-DRV-xxxx series bipolar DC microstepping motor drives. PSBxx switching power supplies are also available from AutomationDirect.

Always check the motor specs and speed-torque curves to determine allowable drive input voltage. To minimize heat loss in the motor, always choose the lowest input voltage that satisfies the application's speed-torque requirements.

Mounting the Motor

We recommend mounting the motor to a metallic surface to help dissipate heat generated by the motor.

Journal Mounting

Below is a list of mounting components that are compatible with the NEMA17 and NEMA23 journal machined end (ADJ) motors. These are not sold by Automaton Direct but McMasterCarr part numbers have been given as an example. This list is not a suggested solution for your application as it may not be suitable. These are for securing the end of the lead screw so it does not move in the radial plane and to provide radial support of the lead screw and load. The bearings in the motor are designed to handle the axial loads not the bearing securing the journal end. The axial load forces should not exceed the force determined by the Speed Force curve for each model.



NOTE: Some of the smaller NEMA 17 lead screws have journals and rear shafts with threads still visible in the machined area. This occurs on screw codes A, B, and C. This is done to maintain minimum shaft diameter. Bearings, bushings, and motor-mounted encoders will still work correctly on the grooved journals. The journal ends do still have a groove for a retaining clip, but may be hard to see.



Journal end with visible threads



Standard journal end

NEMA Rating	Part Number	Description	Quantity
17	98541A113	Retainer for 5mm shaft	1
	6153K69	5mm ID bearing	1
	92161A025	5mm ID wave washer	2
	98089A331	5mm ID x 0.5 mm thick shim	1
23	90967A120	Retainer for 8mm shaft	1
	6661K820	8mm ID bearing	1
	90134A030	5/16" ID wave washer	1
	98089A136	8mm ID x 0.5 mm thick shim	1

STP-LE17-xxxxADJ Journal Mounting

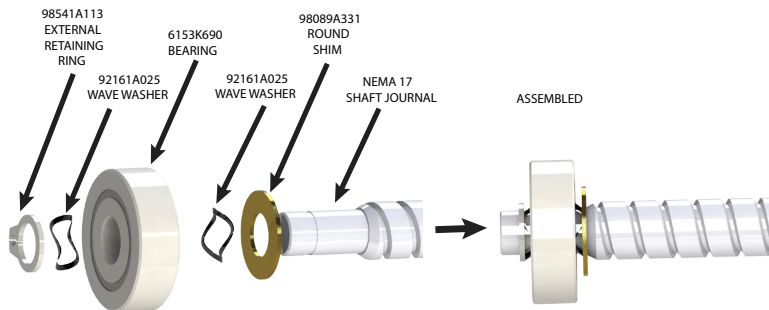

STP-LE23-xxxxADJ Journal Mounting

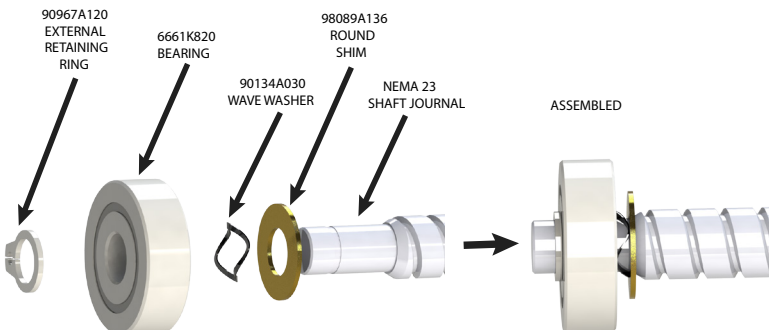

Connecting the Motor



W : When connecting a step motor to a drive or indexer, be sure that the motor power supply is switched off. Never disconnect the motor while the drive is powered up. Never connect the motor leads to ground or directly to the power supply.

All SureStep step STP-MTR series motors have connectorized cables which connect directly to available SureStep extension cables. STP-LA-EXT17-x cables fit the NEMA17 lead screw motors and the STP-LA-EXT23-x cables fit the NEMA 23 lead screw motors.

Extension Cable Wiring Diagrams

STP-LA-EXT17-0xx Dimensions (mm [in])

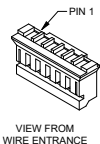
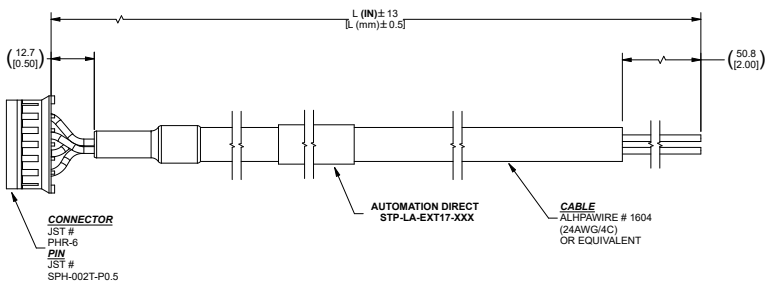

PINOUT CHART		
PIN #	COLOR	WIRE
1	RED	A+
2	N/A	
3	YELLOW	A-
4	GREEN	B+
5	N/A	
6	BLACK	B-

CABLE PART #	CABLES	
	LENGTH L (IN)	LENGTH L (mm)
STP-LA-EXT17-006	72	1828
STP-LA-EXT17-010	120	3048
STP-LA-EXT17-020	240	6096

STP-LA-EXT23-0xx Dimensions (mm [in])

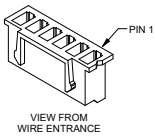
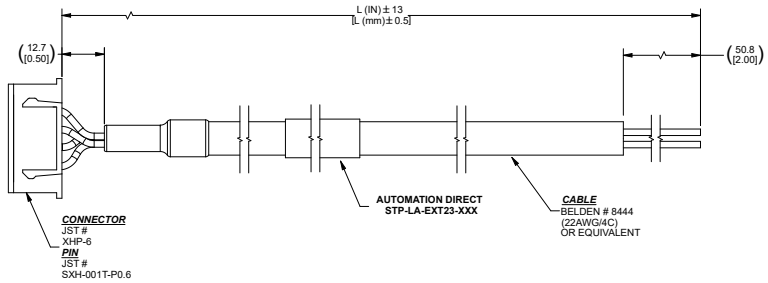

PINOUT CHART		
PIN #	COLOR	WIRE
1	RED	A+
2	N/A	
3	WHITE	A-
4	GREEN	B+
5	N/A	
6	BLACK	B-

CABLES		
CABLE PART #	LENGTH L (IN)	LENGTH L (mm)
STP-LA-EXT23-006	72	1828
STP-LA-EXT23-010	120	3048
STP-LA-EXT23-020	240	6096

Motor Dimensions and Cabling

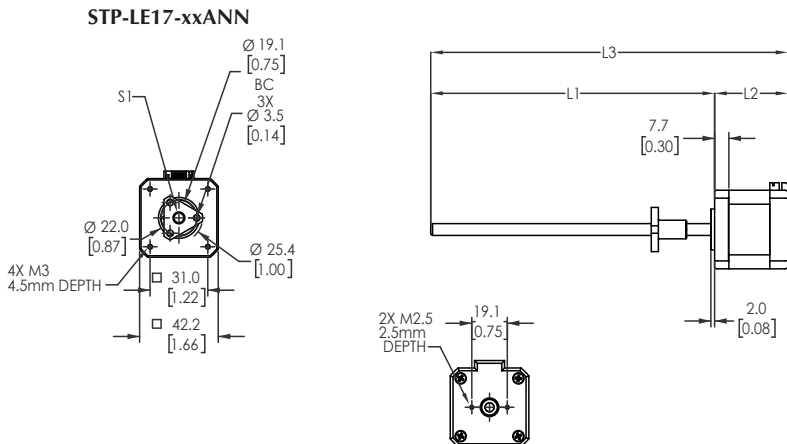

STP-LE17-xxANN Dimensions (mm [in])

Part #	L1	L2	L3	S1
STP-LE17-2A06ANN	152.4 [6.00]	39.3 [1.55]	191.7 [7.55]	6.4 [0.25] 0.25" Lead
STP-LE17-2A09ANN	228.6 [9.00]	39.3 [1.55]	267.9 [10.55]	6.4 [0.25] 0.25" Lead
STP-LE17-2A12ANN	304.8 [12.00]	39.3 [1.55]	344.1 [13.55]	6.4 [0.25] 0.25" Lead
STP-LE17-2C06ANN	152.4 [6.00]	39.3 [1.55]	191.7 [7.55]	6.5 [0.47] 3.0 mm Lead
STP-LE17-2C09ANN	228.6 [9.00]	39.3 [1.55]	267.9 [10.55]	6.5 [0.47] 3.0 mm Lead
STP-LE17-2C12ANN	304.8 [12.00]	39.3 [1.55]	344.1 [13.55]	6.5 [0.47] 3.0 mm Lead
STP-LE17-2D06ANN	152.4 [6.00]	39.3 [1.55]	191.7 [7.55]	8.0 [0.31] 1.25 mm Lead
STP-LE17-2D09ANN	228.6 [9.00]	39.3 [1.55]	267.9 [10.55]	8.0 [0.31] 1.25 mm Lead
STP-LE17-2D12ANN	304.8 [12.00]	39.3 [1.55]	344.1 [13.55]	8.0 [0.31] 1.25 mm Lead
STP-LE17-3A06ANN	152.4 [6.00]	47.8 [1.88]	200.2 [7.88]	6.4 [0.25] 0.25" Lead
STP-LE17-3A09ANN	228.6 [9.00]	47.8 [1.88]	276.4 [10.88]	6.4 [0.25] 0.25" Lead
STP-LE17-3A12ANN	304.8 [12.00]	47.8 [1.88]	352.6 [13.88]	6.4 [0.25] 0.25" Lead
STP-LE17-3B06ANN	152.4 [6.00]	47.8 [1.88]	200.2 [7.88]	6.4 [0.25] 0.5" Lead
STP-LE17-3B09ANN	228.6 [9.00]	47.8 [1.88]	276.4 [10.88]	6.4 [0.25] 0.5" Lead
STP-LE17-3B12ANN	304.8 [12.00]	47.8 [1.88]	352.6 [13.88]	6.4 [0.25] 0.5" Lead
STP-LE17-3E06ANN	152.4 [6.00]	47.8 [1.88]	200.2 [7.88]	8.0 [0.31] 8.0 mm Lead
STP-LE17-3E09ANN	228.6 [9.00]	47.8 [1.88]	276.4 [10.88]	8.0 [0.31] 8.0 mm Lead
STP-LE17-3E12ANN	304.8 [12.00]	47.8 [1.88]	352.6 [13.88]	8.0 [0.31] 8.0 mm Lead

STP-LE17-xxADJ

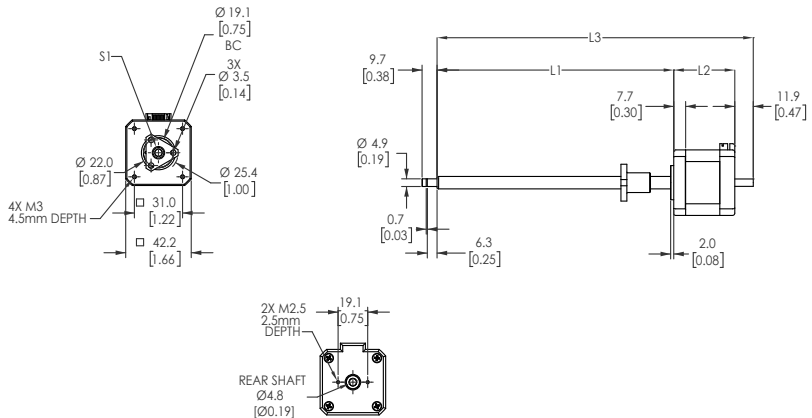

STP-LE17-xxADJ Dimensions (mm [in])

Part #	L1	L2	L3	NA	NB	S1
STP-LE17-2A06ADJ	152.4 [6.00]	39.3 [1.55]	203.6 [8.02]	19.0 [0.75]	10.0 [0.39]	6.4 [0.25] 0.25" Lead
STP-LE17-2A09ADJ	228.6 [9.00]	39.3 [1.55]	279.8 [11.02]	19.0 [0.75]	10.0 [0.39]	6.4 [0.25] 0.25" Lead
STP-LE17-2A12ADJ	304.8 [12.00]	39.3 [1.55]	356.0 [14.02]	19.0 [0.75]	10.0 [0.39]	6.4 [0.25] 0.25" Lead
STP-LE17-2C06ADJ	152.4 [6.00]	39.3 [1.55]	203.6 [8.02]	19.0 [0.75]	10.0 [0.39]	6.5 [0.47] 3.0 mm Lead
STP-LE17-2C09ADJ	228.6 [9.00]	39.3 [1.55]	279.8 [11.02]	19.0 [0.75]	10.0 [0.39]	6.5 [0.47] 3.0 mm Lead
STP-LE17-2C12ADJ	304.8 [12.00]	39.3 [1.55]	356.0 [14.02]	19.0 [0.75]	10.0 [0.39]	6.5 [0.47] 3.0 mm Lead
STP-LE17-2D06ADJ	152.4 [6.00]	39.3 [1.55]	203.6 [8.02]	19.0 [0.75]	12.7 [0.50]	8.0 [0.31] 1.25 mm Lead
STP-LE17-2D09ADJ	228.6 [9.00]	39.3 [1.55]	279.8 [11.02]	19.0 [0.75]	12.7 [0.50]	8.0 [0.31] 1.25 mm Lead
STP-LE17-2D12ADJ	304.8 [12.00]	39.3 [1.55]	356.0 [14.02]	19.0 [0.75]	12.7 [0.50]	8.0 [0.31] 1.25 mm Lead
STP-LE17-3A06ADJ	152.4 [6.00]	47.8 [1.88]	212.1 [8.35]	19.0 [0.75]	10.0 [0.39]	6.4 [0.25] 0.25" Lead
STP-LE17-3A09ADJ	228.6 [9.00]	47.8 [1.88]	288.3 [11.35]	19.0 [0.75]	10.0 [0.39]	6.4 [0.25] 0.25" Lead
STP-LE17-3A12ADJ	304.8 [12.00]	47.8 [1.88]	364.5 [15.35]	19.0 [0.75]	10.0 [0.39]	6.4 [0.25] 0.25" Lead
STP-LE17-3B06ADJ	152.4 [6.00]	47.8 [1.88]	212.1 [8.35]	19.0 [0.75]	10.0 [0.39]	6.4 [0.25] 0.5" Lead
STP-LE17-3B09ADJ	228.6 [9.00]	47.8 [1.88]	288.3 [11.35]	19.0 [0.75]	10.0 [0.39]	6.4 [0.25] 0.5" Lead
STP-LE17-3B12ADJ	304.8 [12.00]	47.8 [1.88]	364.5 [15.35]	19.0 [0.75]	10.0 [0.39]	6.4 [0.25] 0.5" Lead
STP-LE17-3E06ADJ	152.4 [6.00]	47.8 [1.88]	212.1 [8.35]	19.0 [0.75]	12.7 [0.50]	8.0 [0.31] 8.0 mm Lead
STP-LE17-3E09ADJ	228.6 [9.00]	47.8 [1.88]	288.3 [11.35]	19.0 [0.75]	12.7 [0.50]	8.0 [0.31] 8.0 mm Lead
STP-LE17-3E12ADJ	304.8 [12.00]	47.8 [1.88]	364.5 [15.35]	19.0 [0.75]	12.7 [0.50]	8.0 [0.31] 8.0 mm Lead

STP-LE23-xxANN

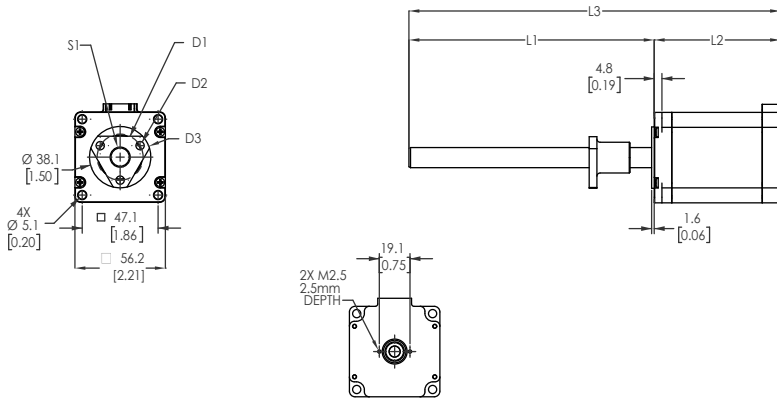

STP-LE23-xxANN Dimensions (mm [in])

Part #	L1	L2	L3	D1	D2	D3	S1
STP-LE23-1F06ANN	152.4 [6.00]	44.5 [1.75]	196.9 [7.75]	Ø22.2 [0.87] BC	3x Ø3.56 [0.14]	Ø29.5 [1.16]	10.0 [0.39] 10.5 mm Lead
STP-LE23-1F09ANN	228.6 [9.00]	44.5 [1.75]	273.1 [10.75]	Ø22.2 [0.87] BC	3x Ø3.56 [0.14]	Ø29.5 [1.16]	10.0 [0.39] 10.5 mm Lead
STP-LE23-1F12ANN	304.8 [12.00]	44.5 [1.75]	349.3 [13.75]	Ø22.2 [0.87] BC	3x Ø3.56 [0.14]	Ø29.5 [1.16]	10.0 [0.39] 10.5 mm Lead
STP-LE23-1G06ANN	152.4 [6.00]	44.5 [1.75]	196.9 [7.75]	Ø28.58 [1.13] BC	3x Ø5.2 [0.20]	Ø38.1 [1.50]	12.0 [0.47] 2.0 mm Lead
STP-LE23-1G09ANN	228.6 [9.00]	44.5 [1.75]	273.1 [10.75]	Ø28.58 [1.13] BC	3x Ø5.2 [0.20]	Ø38.1 [1.50]	12.0 [0.47] 2.0 mm Lead
STP-LE23-1G12ANN	304.8 [12.00]	44.5 [1.75]	349.3 [13.75]	Ø28.58 [1.13] BC	3x Ø5.2 [0.20]	Ø38.1 [1.50]	12.0 [0.47] 2.0 mm Lead
STP-LE23-1H06ANN	152.4 [6.00]	44.5 [1.75]	196.9 [7.75]	Ø28.58 [1.13] BC	3x Ø5.2 [0.20]	Ø38.1 [1.50]	12.0 [0.47] 6.0 mm Lead
STP-LE23-1H09ANN	228.6 [9.00]	44.5 [1.75]	273.1 [10.75]	Ø28.58 [1.13] BC	3x Ø5.2 [0.20]	Ø38.1 [1.50]	12.0 [0.47] 6.0 mm Lead
STP-LE23-1H12ANN	304.8 [12.00]	44.5 [1.75]	349.3 [13.75]	Ø28.58 [1.13] BC	3x Ø5.2 [0.20]	Ø38.1 [1.50]	12.0 [0.47] 6.0 mm Lead
STP-LE23-3H06ANN	152.4 [6.00]	78.5 [3.09]	230.9 [9.09]	Ø28.58 [1.13] BC	3x Ø5.2 [0.20]	Ø38.1 [1.50]	12.0 [0.47] 6.0 mm Lead
STP-LE23-3H09ANN	228.6 [9.00]	78.5 [3.09]	307.1 [12.09]	Ø28.58 [1.13] BC	3x Ø5.2 [0.20]	Ø38.1 [1.50]	12.0 [0.47] 6.0 mm Lead
STP-LE23-3H12ANN	304.8 [12.00]	78.5 [3.09]	383.3 [15.09]	Ø28.58 [1.13] BC	3x Ø5.2 [0.20]	Ø38.1 [1.50]	12.0 [0.47] 6.0 mm Lead
STP-LE23-3K06ANN	152.4 [6.00]	78.5 [3.09]	230.9 [9.09]	Ø28.58 [1.13] BC	3x Ø5.2 [0.20]	Ø38.1 [1.50]	12.5 [0.50] 1in Lead
STP-LE23-3K09ANN	228.6 [9.00]	78.5 [3.09]	307.1 [12.09]	Ø28.58 [1.13] BC	3x Ø5.2 [0.20]	Ø38.1 [1.50]	12.5 [0.50] 1in Lead
STP-LE23-3K12ANN	304.8 [12.00]	78.5 [3.09]	383.3 [15.09]	Ø28.58 [1.13] BC	3x Ø5.2 [0.20]	Ø38.1 [1.50]	12.5 [0.50] 1in Lead

STP-LE23-xxADJ

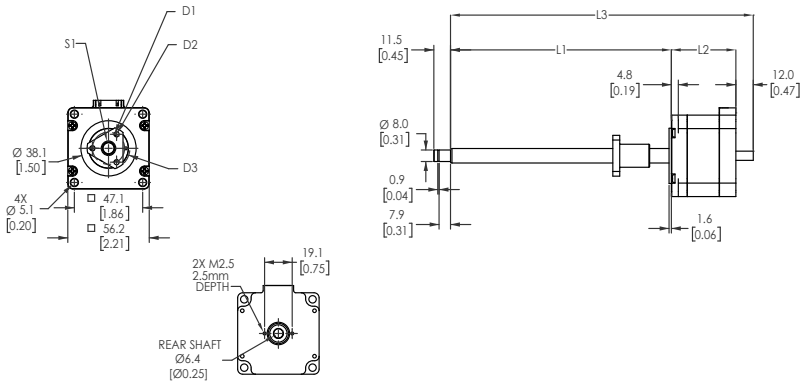

STP-LE23-xxADJ Dimensions (mm [in])

Part #	L1	L2	L3	D1	D2	D3	S1
STP-LE23-1F06ADJ	152.4 [6.00]	44.5 [1.75]	208.9 [8.22]	Ø22.2 [0.87] BC	3x Ø3.56 [0.14]	Ø29.5 [1.16]	10.0 [0.39] 10.5 mm Lead
STP-LE23-1F09ADJ	228.6 [9.00]	44.5 [1.75]	285.1 [11.22]	Ø22.2 [0.87] BC	3x Ø3.56 [0.14]	Ø29.5 [1.16]	10.0 [0.39] 10.5 mm Lead
STP-LE23-1F12ADJ	304.8 [12.00]	44.5 [1.75]	361.3 [14.22]	Ø22.2 [0.87] BC	3x Ø3.56 [0.14]	Ø29.5 [1.16]	10.0 [0.39] 10.5 mm Lead
STP-LE23-1G06ADJ	152.4 [6.00]	44.5 [1.75]	208.9 [8.22]	Ø28.58 [1.13] BC	3x Ø5.2 [0.20]	Ø38.1 [1.50]	12.0 [0.47] 2.0 mm Lead
STP-LE23-1G09ADJ	228.6 [9.00]	44.5 [1.75]	285.1 [11.22]	Ø28.58 [1.13] BC	3x Ø5.2 [0.20]	Ø38.1 [1.50]	12.0 [0.47] 2.0 mm Lead
STP-LE23-1G12ADJ	304.8 [12.00]	44.5 [1.75]	361.3 [14.22]	Ø28.58 [1.13] BC	3x Ø5.2 [0.20]	Ø38.1 [1.50]	12.0 [0.47] 2.0 mm Lead
STP-LE23-1H06ADJ	152.4 [6.00]	44.5 [1.75]	208.9 [8.22]	Ø28.58 [1.13] BC	3x Ø5.2 [0.20]	Ø38.1 [1.50]	12.0 [0.47] 6.0 mm Lead
STP-LE23-1H09ADJ	228.6 [9.00]	44.5 [1.75]	285.1 [11.22]	Ø28.58 [1.13] BC	3x Ø5.2 [0.20]	Ø38.1 [1.50]	12.0 [0.47] 6.0 mm Lead
STP-LE23-1H12ADJ	304.8 [12.00]	44.5 [1.75]	361.3 [14.22]	Ø28.58 [1.13] BC	3x Ø5.2 [0.20]	Ø38.1 [1.50]	12.0 [0.47] 6.0 mm Lead
STP-LE23-3H06ADJ	152.4 [6.00]	78.5 [3.09]	242.9 [9.06]	Ø28.58 [1.13] BC	3x Ø5.2 [0.20]	Ø38.1 [1.50]	12.0 [0.47] 6.0 mm Lead
STP-LE23-3H09ADJ	228.6 [9.00]	78.5 [3.09]	319.1 [12.56]	Ø28.58 [1.13] BC	3x Ø5.2 [0.20]	Ø38.1 [1.50]	12.0 [0.47] 6.0 mm Lead
STP-LE23-3H12ADJ	304.8 [12.00]	78.5 [3.09]	395.3 [15.56]	Ø28.58 [1.13] BC	3x Ø5.2 [0.20]	Ø38.1 [1.50]	12.0 [0.47] 6.0 mm Lead
STP-LE23-3K06ADJ	152.4 [6.00]	78.5 [3.09]	242.9 [9.06]	Ø28.58 [1.13] BC	3x Ø5.2 [0.20]	Ø38.1 [1.50]	12.5 [0.50] 1in Lead
STP-LE23-3K09ADJ	228.6 [9.00]	78.5 [3.09]	319.1 [12.56]	Ø28.58 [1.13] BC	3x Ø5.2 [0.20]	Ø38.1 [1.50]	12.5 [0.50] 1in Lead
STP-LE23-3K12ADJ	304.8 [12.00]	78.5 [3.09]	395.3 [15.56]	Ø28.58 [1.13] BC	3x Ø5.2 [0.20]	Ø38.1 [1.50]	12.5 [0.50] 1in Lead

Thrust vs. Speed Charts

The dashed horizontal lines indicate the maximum thrust allowed by the nut. Note that some motors and leads can result in thrust above the nut's limit. Ensure that the system does not apply too much force to the nut (example: limit the motor current, or monitor position feedback to determine a stall). Allow sufficient time to accelerate the load and size the step motor with a 100% thrust safety factor (i.e.: design the system using a maximum of 50% of the motor's thrust).

STP-LE17-2xxxx (Double-stack motors)

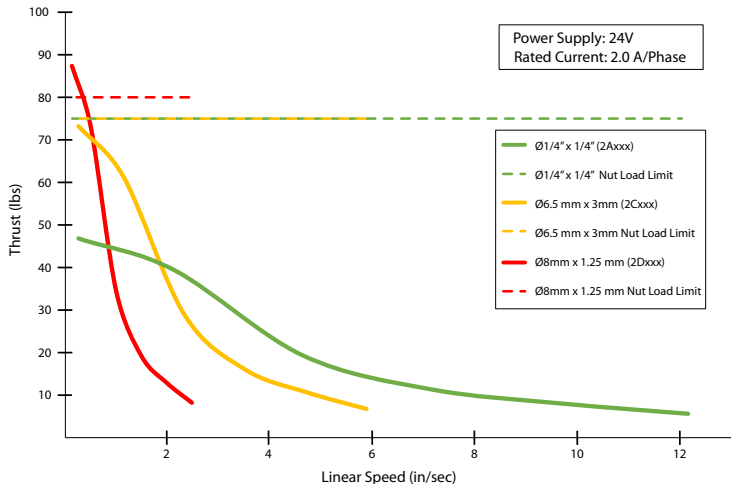

STP-LE17-3xxxx (Triple-stack motors)

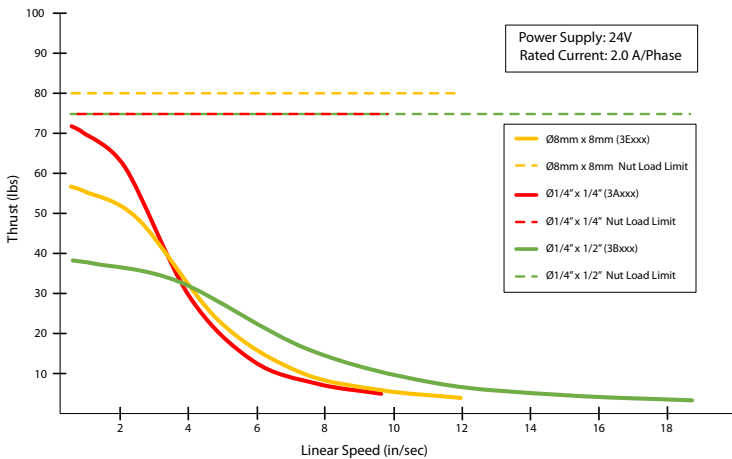

STP-LE23-1xxxx (Single-stack motors)

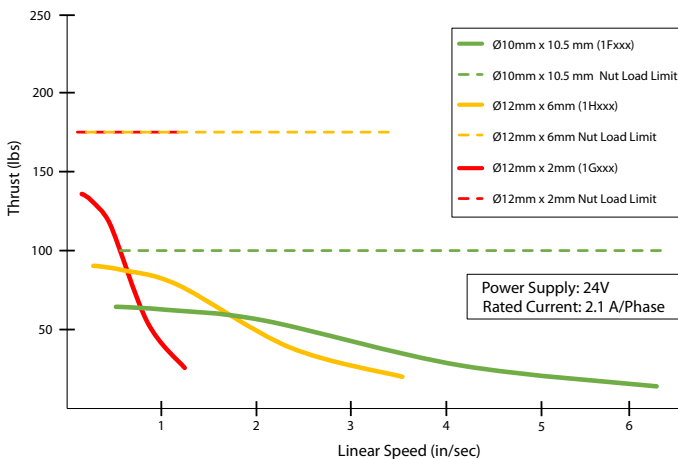

STP-LE23-3xxxx (Triple-stack motors)

