

# SureStep™ STEPPING SYSTEMS

## Stepping System Power Supplies STP-PWR-3204, 4805, 4810, 7005



### Features

- Models available with 32V@4A, 48V@5A, 48V@10A, & 70V@5A DC unregulated step motor power
- 5VDC ±5% at 500 mA regulated logic power (electronic overload)
- Screw terminal AC input and DC output connectors
- 120 or 240 VAC, 50/60 Hz power input, switch selectable
- Power ON LEDs
- Integrated input and output fusing
- Matched to SureStep drives for maximum voltage

### WARNING

To minimize the risk of potential safety problems, you should follow all applicable local and national codes that regulate the installation and operation of your equipment. These codes vary from area to area. It is your responsibility to determine which codes should be followed, and to verify that the equipment, installation, and operation are in compliance with the latest revision of these codes.

*Equipment damage or serious injury to personnel can result from the failure to follow all applicable codes and standards. We do not guarantee the products described in this publication are suitable for your particular application, nor do we assume any responsibility for your product design, installation, or operation.*

If you have any questions concerning the installation or operation of this equipment, or if you need additional information, please call our technical support group at 770-844-4200.

This publication is based on information that was available at the time it was printed. At [AutomationDirect.com](http://AutomationDirect.com)® we constantly strive to improve our products and services, so we reserve the right to make changes to the products and/or publications at any time without notice and without obligation. This publication may also discuss features that may not be available in certain revisions of the product.

SureStep™ Power Supply Specifications				
Part Number	STP-PWR-3204	STP-PWR-4805	STP-PWR-4810	STP-PWR-7005
<b>Input Power fuse protected (1)</b>	1-phase, 120/240 VAC, 50/60 Hz, 150 VA Fuse(1): 3A	1-phase, 120/240 VAC, 50/60 Hz, 350 VA Fuse(1): 5A	1-phase, 120/240 VAC, 50/60 Hz, 650 VA Fuse(1): 8A	1-phase, 120/240 VAC, 50/60 Hz, 500 VA Fuse(1): 7A
<b>Input Voltage</b>	120/240 VAC ±10% (switch selectable; voltage range switch is set to 240 VAC from factory)			
<b>Inrush Current</b>	120 VAC < 12A 240 VAC < 14A	120 VAC < 20A 240 VAC < 24A	120 VAC < 40A 240 VAC < 50A	
<b>Motor Supply Output (linear unregulated, fuse protected (1), power on LED indicator)</b>	32 VDC @ 4A (full load) 35 VDC @ 1A load 41 VDC @ no load Fuse(1): 6A	46.5 VDC @ 5A (full load) 52 VDC @ 1A load 57.5 VDC @ no load Fuse(1): 8A	46.5 VDC @ 10A (full load) 50 VDC @ 1A load 57.5 VDC @ no load Fuse(1): 15A	70 VDC @ 5A (full load) 79 VDC @ 1A load 86.5 VDC @ no load Fuse(1): 8A
<b>SureStep Drive Compatibility (2)</b>	STP-DRV-4035 (STP-DRV-4850) (STP-DRV-80100)	STP-DRV-4850 (STP-DRV-80100)		STP-DRV-80100
<b>Logic Supply Output</b>	5VDC ±5% @ 500 mA (regulated, electronically overload protected, power on LED indicator)			
<b>Watt Loss</b>	13W	25W	51W	42W
<b>Storage Temperature</b>	-55 to 85 °C -67 to 185 °F			
<b>Operating Temperature</b>	0 to 50 °C (32 to 122 °F) full rated; 70 °C (158 °F) maximum Derate current 1.1% per degree above 50 °C			
<b>Humidity</b>	95% (non-condensing) relative humidity maximum			
<b>Cooling Method</b>	Natural convection (mount power supply to metal surface if possible)			
<b>Dimensions (in [mm])</b>	4.00 x 7.00 x 3.25 [101.6 x 177.8 x 82.6]	5.00 x 8.10 x 3.88 [127.0 x 205.7 x 98.6]	5.62 x 9.00 x 4.62 [142.7 x 228.6 x 117.3]	
<b>Mounting</b>	Mount on either wide or narrow side with machine screws per dimension diagrams			
<b>Weight (lb [kg])</b>	6.5 [2.9]	11 [4.9]	18 [8.3]	16 [7.2]
<b>Connections</b>	Screw Terminals, tightening torque of 4.5 in-lbs			
<b>Agency Approvals</b>	UL (file # E181899), CSA, CE			
<b>1) Fuses to be replaced by qualified service personnel only.</b> Use (1-1/4 x 1/4 in) ceramic fast-acting fuses (Edison type ABC from AutomationDirect, or equivalent).				
<b>2) Caution: Do not use a power supply that exceeds the drive input voltage range.</b> Using a lower voltage power supply with a higher voltage drive is acceptable, but will not provide full system performance.				

SureStep Power Supply / Drive Compatibility				
Drive(1)(2)	Recommended Power Supply(1)(2)			
Model #	STP-PWR-3204	STP-PWR-4805	STP-PWR-4810	STP-PWR-7005
STP-DRV-4035	YES	-	-	-
STP-DRV-4830	YES	YES	YES	-
STP-DRV-4845	YES	YES	YES	-
STP-DRV-4850	YES	YES	YES	-
STP-DRV-6575	YES	YES	YES	-
STP-DRV-80100	YES	YES	YES	YES
<b>1) Do NOT use a power supply that exceeds the drive's input voltage range. If using a non-STP linear power supply, ensure that the unloaded voltage does not float above the drive's maximum input range.</b>				
<b>2) For best performance, use the lowest voltage power supply that supplies the required speed and torque.</b>				

### Power Supply Terminal & Component Layout

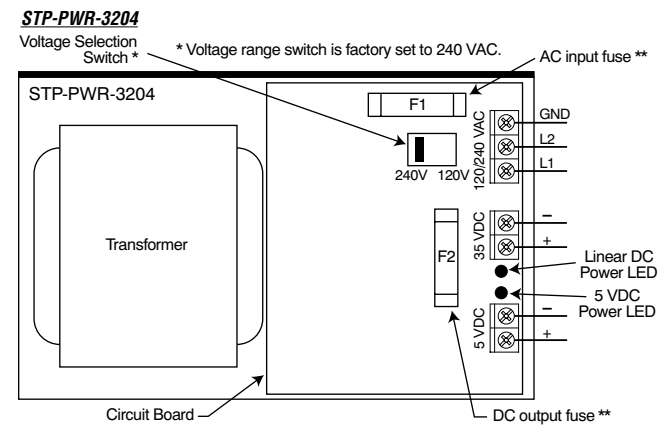

\*\* Fuses are listed in power supply specifications table.  
\*\* Fuses to be replaced by qualified service personnel only.

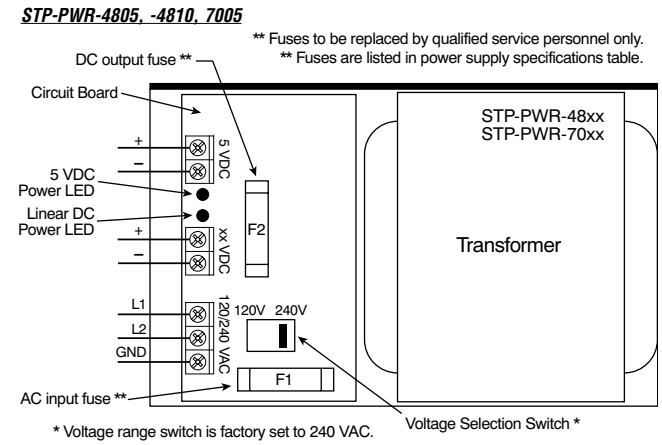

\*\* Fuses to be replaced by qualified service personnel only.  
\*\* Fuses are listed in power supply specifications table.

### Mounting the Power Supply

STP-PWR-xxxx power supplies can be mounted on either the bottom (wide) side, or the back (narrow) side of the chassis. Either orientation contains mounting holes for machine screws. Use #10 screws for STP-PWR-3204 and -4805, or 1/4" screws for STP-PWR-4810 and -7005.

### WARNING

Never use the power supply in a space where there is no air flow, or where the surrounding air temperature is greater than 70 °C. Since power supplies generate heat, they should be securely fastened to a smooth, flat metal surface that will dissipate heat.

# SureStep™ STEPPING SYSTEMS

Stepping System Power Supplies  
STP-PWR-3204, -4805, -4810, -7005

## Dimensions

### STP-PWR-3204

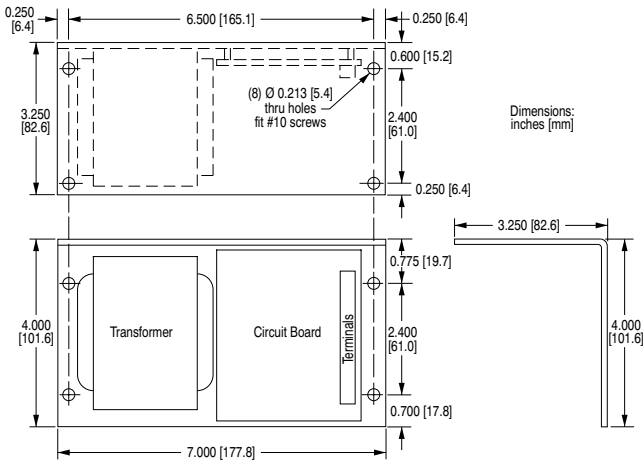

## Dimensions

### STP-PWR-4805, -4810, -7005

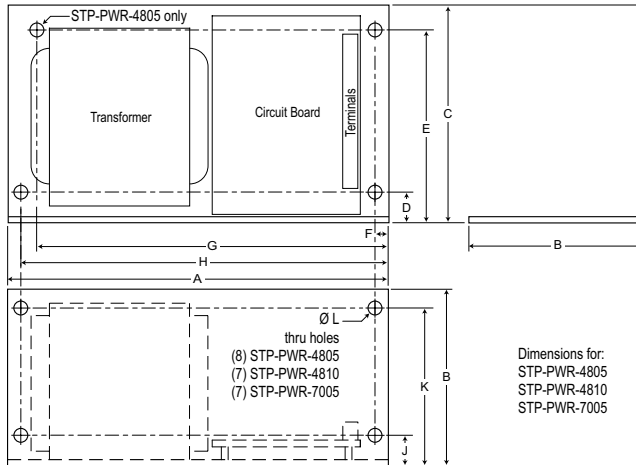

SureStep™ Series Dimensions – 48V & 70V Power Supplies			
Dimensions* (in [mm])*	Power Supply Part Number		
	STP-PWR-4805	STP-PWR-4810	STP-PWR-7005
<b>A</b>	8.10 [205.7]		9.00 [228.6]
<b>B</b>	3.88 [98.6]		4.62 [117.3]
<b>C</b>	5.00 [127.0]		5.62 [142.7]
<b>D</b>	0.87 [22.1]		1.56 [39.6]
<b>E</b>	4.67 [118.6]		4.06 [103.1]
<b>F</b>	0.25 [6.4]		0.35 [8.9]
<b>G</b>	7.15 [181.6]		n/a
<b>H</b>	7.75 [196.9]		8.59 [218.2]
<b>J</b>	0.50 [12.7]		0.50 [12.7]
<b>K</b>	3.53 [89.7]		4.27 [108.5]
<b>L</b>	0.200 [5.1]		9/32 [7.1]
<b>Mtg Screw</b>	#10		1/4

\* mm dimensions are for reference purposes only.