

Key transfer plan

SAFEMASTER STS

Safety Switch and Key Interlock System

Company: Automation Direct

Location: USA

Customer no: 9154127

Order number:

Confirmation no:

Project no: S101326

Proposal: 1

Version: 2

Project: 2 doors with switch

Date: 21.02.2013

Part list:

Qty.	item	order number
2	B-module	0061873
5	M-module	0060987
4	bayonet ring	0060988
2	coded key	0060985
2	10-module	0061870
2	01-module	0061871
1	SX-module	0060797

description:
STS-SX02M

01-Module
Label
A
Code

01-Module
Label
A
Code

SX-2GATE-SET

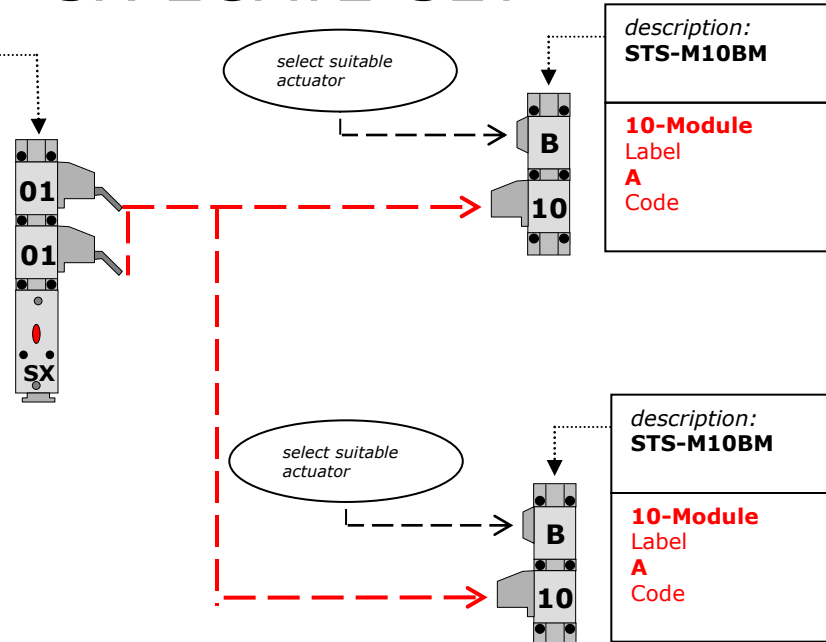

Caution

This key transfer plan is copyright protected and was made as a proposal based upon data made available to us. Before commissioning the user has to verify if this proposal meets the requirements and if all accesses are properly safeguarded. For further informations see design guide Safemaster STS.