

Communications Port Adapter with Surge Protection and Comm Status Indication Installation Instructions

ZL-CMA15L

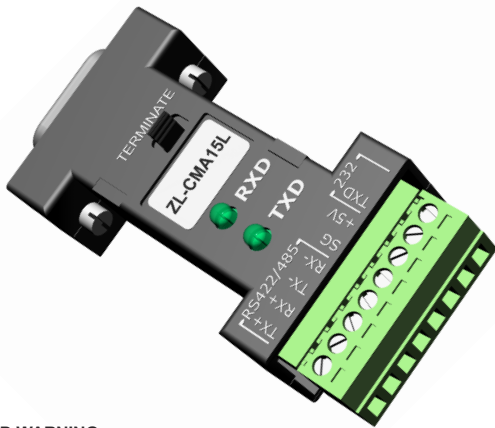

HAZARD WARNING

- A. THIS EQUIPMENT IS SUITABLE FOR USE IN CLASS I, DIVISION 2/ZONE 2, GROUPS A, B, C AND D OR NON-HAZARDOUS LOCATIONS ONLY.
- B. **WARNING – EXPLOSION HAZARD** – SUBSTITUTION OF COMPONENTS MAY IMPAIR SUITABILITY FOR CLASS I, DIVISION 2/ZONE 2.
- C. **WARNING – EXPLOSION HAZARD** – DO NOT CONNECT OR DISCONNECT CONNECTORS OR OPERATE SWITCHES WHILE CIRCUIT IS LIVE UNLESS THE AREA IS KNOWN TO BE NON-HAZARDOUS.

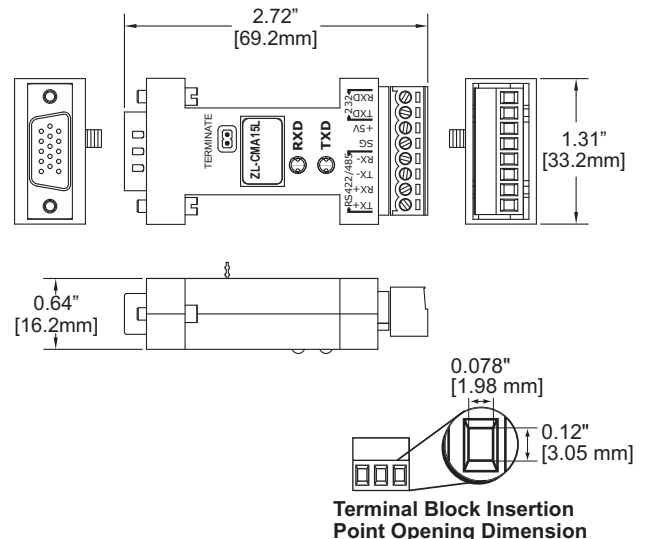
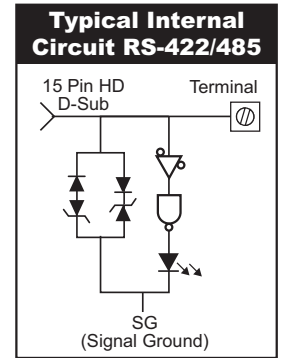
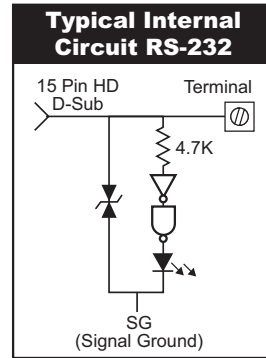
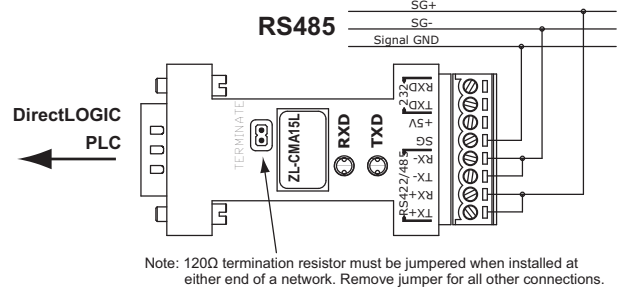
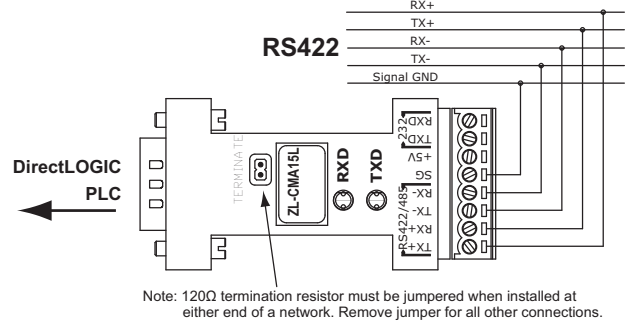
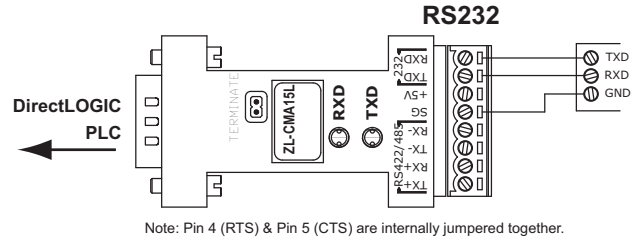
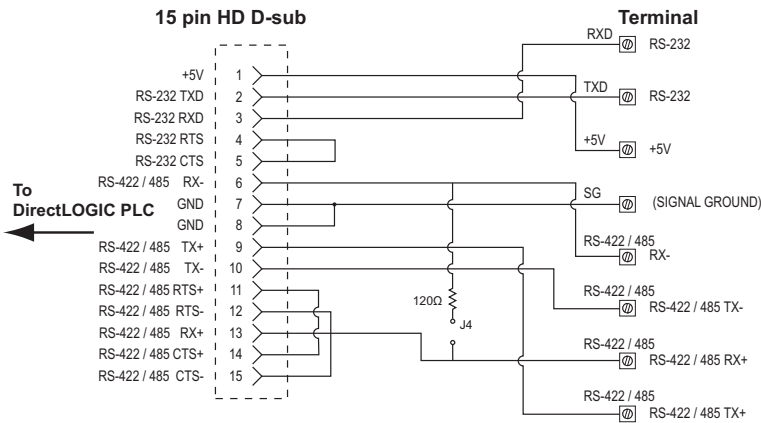

Specifications									
Description	DL06, D2-250-1 and D2-260 PLC Port 2 adapter: HD 15-pin D-sub to terminal block								
Approvals*	File # E200031 Approved for use in Class 1 Division 2, Groups A, B, C, D Hazardous Locations, CE, EN 61131-2:2007								
Communications Interface	RS232, RS422, RS485								
Indication Transmit Data	Green LED								
Indication Receive Data	Green LED								
RS232 Surge Protection	2 Circuits clamped by zener transient voltage suppressors								
RS422/485 Surge Protection	4 Circuits clamped by low capacitance zener diodes								
RS422/485 Network Termination Resistor	Jumper Selectable 120Ω								
Voltage Rating*	30VDC								
Maximum Current per Circuit	1A								
Supported Signal Lines	<table border="0"> <tr> <td>RS-422/485 TXD+</td> <td>RS-422/485 TXD-</td> </tr> <tr> <td>RS-422/485 RXD+</td> <td>RS-422/485 RXD-</td> </tr> <tr> <td>RS-232 TXD</td> <td>RS-232 RXD</td> </tr> <tr> <td>+5VDC PWR</td> <td>Ground</td> </tr> </table>	RS-422/485 TXD+	RS-422/485 TXD-	RS-422/485 RXD+	RS-422/485 RXD-	RS-232 TXD	RS-232 RXD	+5VDC PWR	Ground
RS-422/485 TXD+	RS-422/485 TXD-								
RS-422/485 RXD+	RS-422/485 RXD-								
RS-232 TXD	RS-232 RXD								
+5VDC PWR	Ground								
Terminal Block Contacts	Copper alloy, tin-lead plating								
Wire Range (Rated Cross Section)*	16-28AWG Solid or Stranded Conductor (1.5mm ²)								
Wire Strip Length	0.24-0.27" (6-7mm)								
Screw Torque	1.7 in-lbs (0.2 Nm)								
Surrounding Temperature Range	32 to 140°F (0 to 60°C)								
Dimensions (WxHxD)	1.31" x 0.64" x 2.72" (33.2 x 16.2 x 69.2 mm)								

*Use Class 2 Power Supply. Use conductors rated 60°/75°C.

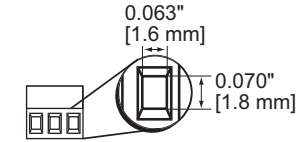

**Terminal Block Insertion
Point Opening Dimension**

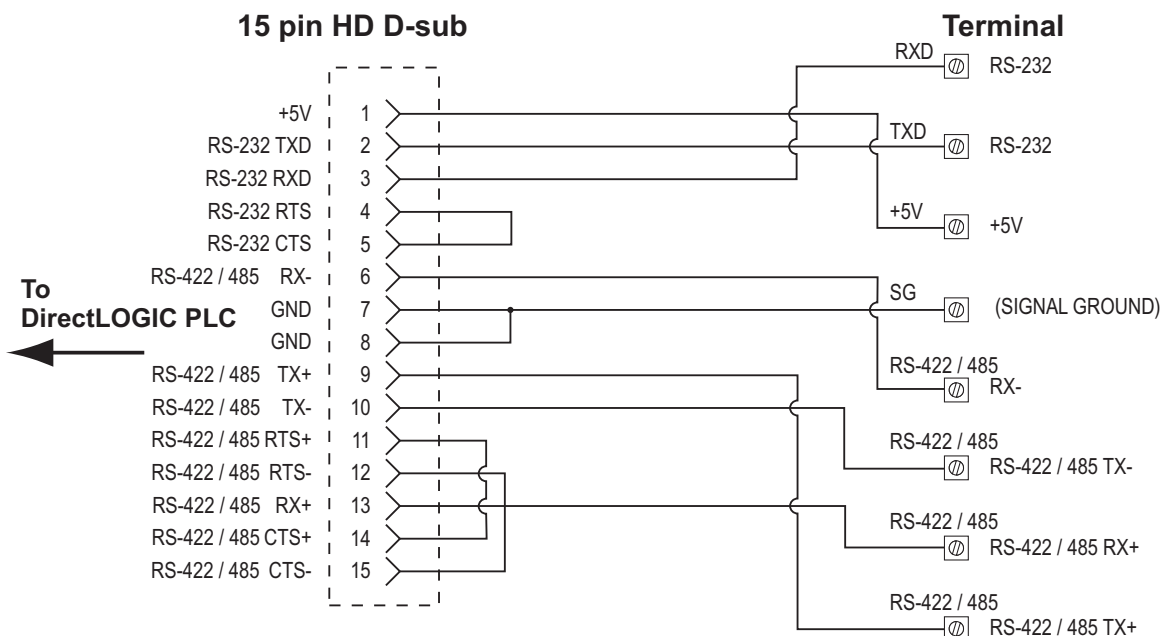
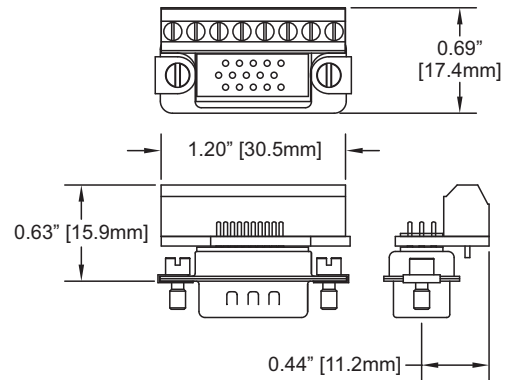

WARNING: To minimize the risk of potential safety problems, you should follow all applicable local and national codes that regulate the installation and operation of your equipment. These codes vary from area to area and it is your responsibility to determine which codes should be followed, and to verify that the equipment, installation, and operation are in compliance with the latest revision of these codes.

Equipment damage or serious injury to personnel can result from the failure to follow all applicable codes and standards. We do not guarantee the products described in this publication are suitable for your particular application, nor do we assume any responsibility for your product design, installation, or operation.

If you have any questions concerning the installation or operation of this equipment, or if you need additional information, please call Technical Support at 770-844-4200.

This publication is based on information that was available at the time it was printed. At AutomationDirect.com we constantly strive to improve our products and services, so we reserve the right to make changes to the products and/or publications at any time without notice and without any obligation. This publication may also discuss features that may not be available in certain revisions of the product.

Specifications

Description	DL06, D2-250-1 and D2-260 PLC Port 2 adapter: HD 15-pin D-sub to terminal block	
Approvals*	File # E200031 Approved for use in Class 1 Division 2, Groups A, B, C, D Hazardous Locations, CE, EN 61131-2:2007	
Communications Interface	RS232, RS422, RS485	
Voltage Rating	30VDC	
Max. Current per Circuit	1A	
Supported Signal Lines	RS-422/485 TXD+ RS-422/485 RXD+ RS-232 TXD +5VDC PWR	RS-422/485 TXD- RS-422/485 RXD- RS-232 RXD Ground
Wire Range (Rated Cross Section)*	16-30AWG Solid or Stranded Conductor (1.5mm ²)	
Wire Strip Length	0.24-0.27" (6-7mm)	
Screw Torque	1.7 in-lbs (0.2 Nm)	
Surrounding Temperature Range	32 to 140°F (0 to 60°C)	
Dimensions (WxHxD)	1.20" x 0.69" x 0.63" (30.5mm x 17.4mm x 15.9mm)	

*Use Class 2 Power Supply. Use conductors rated 60°/75°C.

HAZARD WARNING

A. THIS EQUIPMENT IS SUITABLE FOR USE IN CLASS I, DIVISION 2/ZONE 2, GROUPS A, B, C AND D OR NON-HAZARDOUS LOCATIONS ONLY.

B. **WARNING – EXPLOSION HAZARD** – SUBSTITUTION OF COMPONENTS MAY IMPAIR SUITABILITY FOR CLASS I, DIVISION 2/ZONE 2.

C. **WARNING – EXPLOSION HAZARD** – DO NOT CONNECT OR DISCONNECT CONNECTORS OR OPERATE SWITCHES WHILE CIRCUIT IS LIVE UNLESS THE AREA IS KNOWN TO BE NON-HAZARDOUS.