

EIFys SM322

Photodetector Datasheet



1. Product Description and Key Features

EIFys SM series photodiode products consist of EIFys patented Black Silicon Induced Junction Technology. Product patent information can be found at <https://www.elfys.fi/index.php/technology/patent/>. EIFys SM series photodiode products provide superior performance of photosensitivity in visible and near infrared spectrum. The product is especially suitable for health monitoring applications in wearable devices. The high sensitivity of the product offers more output photocurrent and improves the energy efficiency of PPG (photoplethysmography) module. Together with its compact packaging and high fill factor of photosensitive area, it facilitates innovative wearable products design.

Key feature: Enhanced photosensitivity to Green, Red and NIR wavelength
 Key applications: HRM, SpO2 for wearables

Part number	Photosensitive area (mm ²)	Packaging	Outline dimensions (mm)	Reverse Voltage (V) Max.	Operation temperature °C
SM322	3.22	PCB, moulded optical epoxy	3.2 x 2.0 x 0.6	6	-40...+85

2. Values of Electrical and Optical Performance

Part number	Spectral response range	Peak response wavelength, λ_p	Photosensitivity				Dark current @ $V_R=10mV$, Max.	Capacitance @ $V_R=0V$, $f=100kHz$, Typ.	Noise equivalent power NEP @ λ_p Typ.
			λ_p Typ.	540nm Typ.	630nm Typ.	940nm Typ.			
	nm	nm	A/W	A/W	A/W	A/W	pA	pF	W/√Hz
SM322	400-1100	970	0.71	0.40	0.47	0.70	40	60	9×10^{-15}

Note: All data are specified at typical ambient temperature (25°C) and under normal working conditions.



3. Spectral Response (Typical)

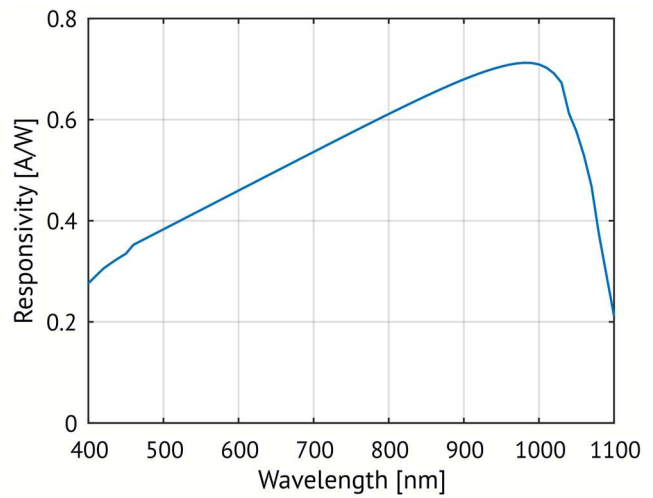
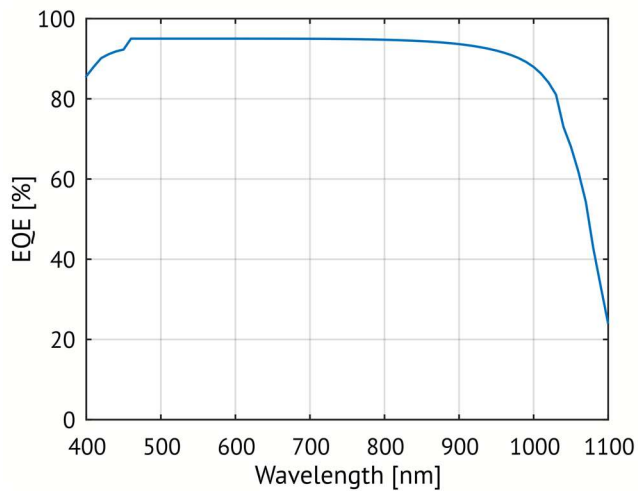

4. Dark current and capacitance vs Reverse bias (Typical)

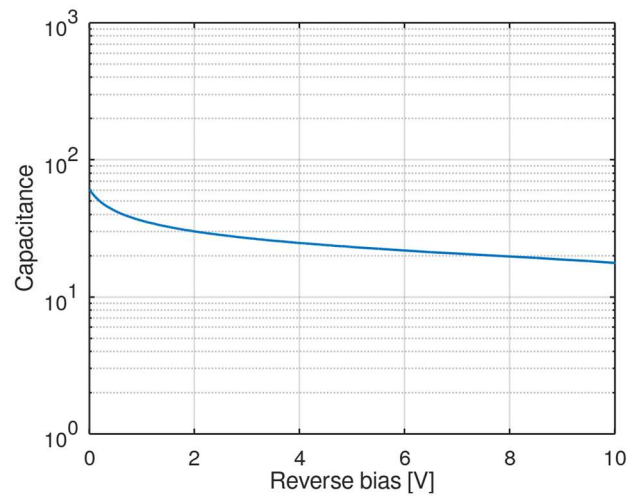
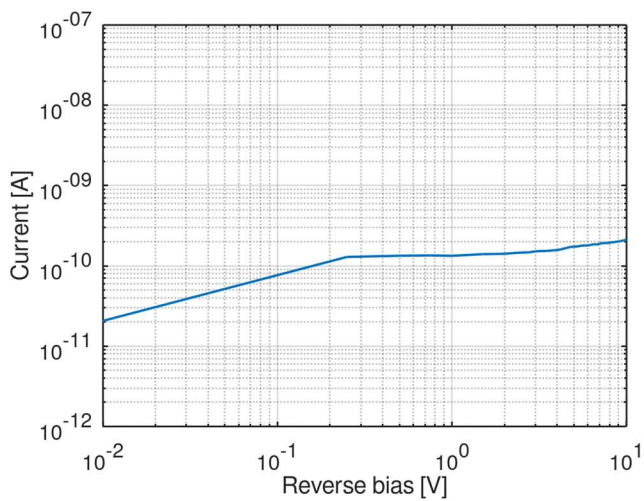

5. Packaging and Dimensions

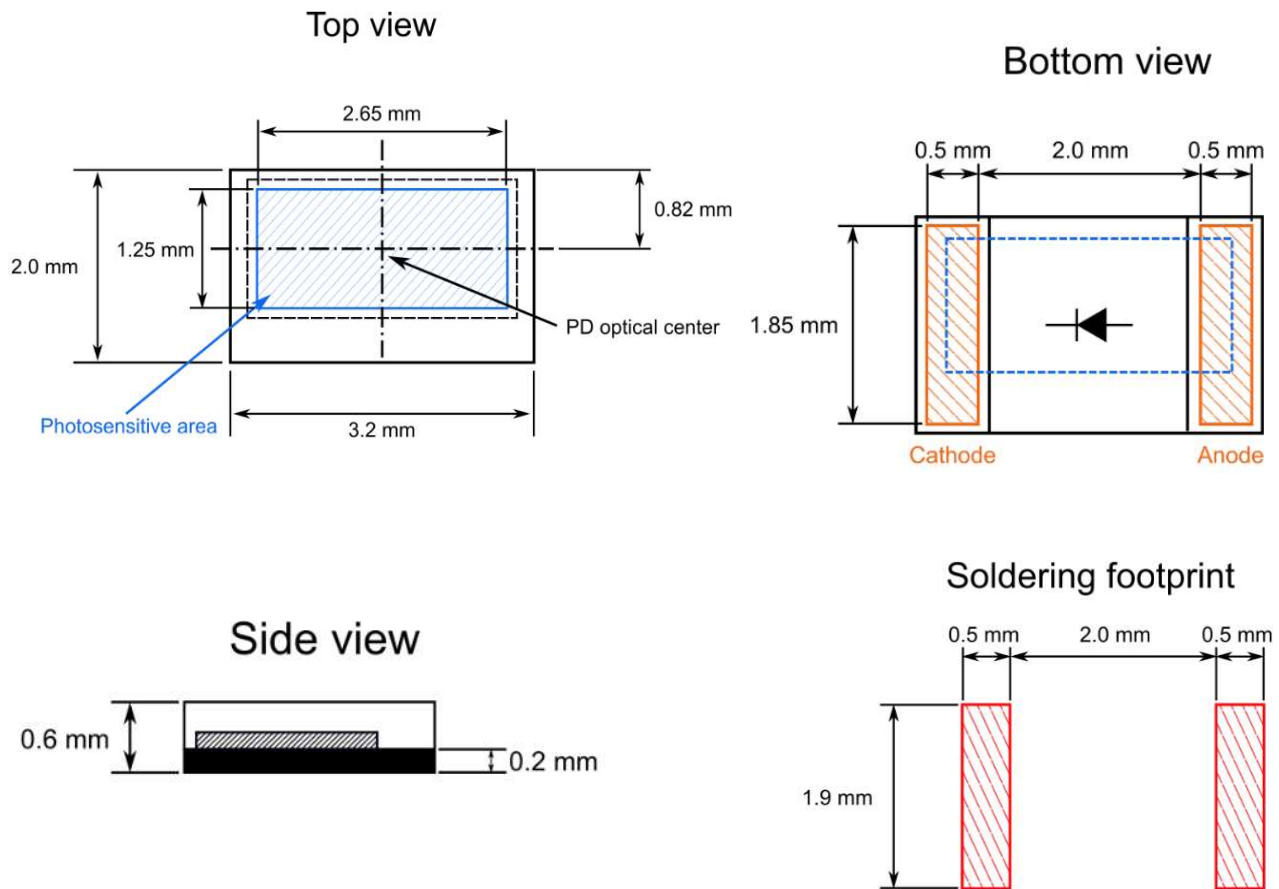

Assembly conditions:

Soldering temperature (maximum): + 255°C (according to suitable reflow solder profile)

ELFYS, Inc. reserves the right to change product specification without prior notice.