

Quality management of 3D cultural heritage replicas with CIDOC-CRM

Nicola Amico¹, Paola Ronzino¹, Achille Felicetti¹, Franco Niccolucci²

¹PIN, VAST-LAB, Prato, Italy

{nicola.amico, paola.ronzino, achille.felicetti}@pin.unifi.it

²PIN, VAST-LAB, Prato, Italy

franco.niccolucci@unifi.it

Abstract. The paper proposes to use CIDOC-CRM and its extension CRMdig to document the planning and execution of 3D models of cultural objects in order to manage the quality of the replicas. Full documentation of every process is key to guarantee the quality of the outcomes according to the industrial approach to quality known as Quality Management, for example as described to ISO9001:2008.

Keywords. CIDOC-CRM extension, Quality Management, 3D replicas, cultural heritage

1 Introduction

The use of visual aids to model cultural heritage, besides textual description, has always accompanied the design, planning, creation and documentation of monuments and artifacts. Recently, 3D models are increasingly used thanks to the visualization capabilities of computers and the availability of high-performance graphic cards. A further push to the adoption of 3D models comes from the diffusion of technologies like 3D scanning and photogrammetry that make 3D modeling a widely available methodology. Nowadays it is being adopted for mass acquisition of artifacts and monuments and 3D datasets are stored in an increasing number in openly accessible digital libraries. For example, there are projects aiming at populating Europeana, the European digital library, with 3D models of European art, archaeology and architecture masterpieces or creating tools for the creation of collections of digital replicas of cultural objects [1, 2]. However, issues have been raised about the quality of the 3D models and their suitability to become a substitute of the original, leading to the statement of widely accepted general principles [3]. An engineering approach to quality is based on the quest for details and accuracy and measures quality in microns (model resolution) and number of polygons (level of detail: LOD).

This approach is technology-driven and does not take into account the customers' requirements and perspective. It is also cumbersome to implement, because it requires ex-post verification of the model. Finally, it does not take into account the data acquisition conditions that might adversely influence the model quality, regardless of its

pretended precision. Some institutions in recent years started to define guidelines for a correct use of 3D laser scanner for cultural heritage [4, 5, 6, 7]. The idea behind this approach is that if the acquisition is done “at best”, the result can only be good. This is correct, but how can a subsequent user know it and trust the model? As regards 2D, for instance, it is suggested [8] that direct inspection is carried out either on all the models or on a sample of them – what is clearly unfeasible in the case of complex 3D models.

In a way similar to industry standards, for example ISO9001:2008, a better approach should consider the entire pipeline of 3D model production and document the entire workflow. This will not produce ‘good’ models by itself, but it will produce consistent models and enable users to assess their trustworthiness and suitability for purpose, thus enabling re-use. Documentation is crucial to this model, and a suitable documentation system is – as far as we know – still unavailable. CRMdig [9] marked a significant step towards this goal by extending the well-known CIDOC-CRM to digital matters. In the present paper we propose a draft documentation system for the production of 3D models using laser scanners, based on CIDOC-CRM and its extension CRMdig. Other technologies to create 3D models will follow shortly. A similar approach has been proposed and adopted, in a simplified way, by the already mentioned 3D ICONS project [1]. Experience gained on 3D scanning highlighted issues on the procedures adopted, which can vary in relation with the chosen artifact. Indeed each object has to be scanned following special pipeline related to the object features. Our system considers all the steps of the design and creation of the model until it can be released for further processing or direct use “as is” and this procedure has been tested in a number of archaeological artifacts with a satisfactory result. A similar approach has been proposed and adopted, in a simplified way, by the already mentioned 3D ICONS project [1]

2 The scanning workflow

The laser scanner workflow consist of a number of steps, some of which need to follow a precise order. They are:

- Aim definition: this step is preliminary and aims at defining the purpose of the digitization. For example, this could be ‘modeling for cultural documentation’, ‘production of models for dissemination’, ‘creation of 3D models for virtual restoration’ and so on.
- Location survey: here a reconnaissance is carried out. The location where the scanning will be performed is surveyed, analyzing the environmental conditions (lighting, temperature, presence of dust, etc.), the features and size of the object compared with the device to be used for the work, and the ‘scene’, i.e. the background surrounding the object to be scanned, for instance, in the case of a monument, the location where it is placed; for a museum object, the space available for scanning, etc. The information recorded includes notes, pictures, sketches, measurements (e.g. of light) and so on. Among others, this stage will support defining the best time to collect the data, identify the presence of highly reflective surfaces, obstruc-

tions and obstacles that may cause voids and artifacts. In outdoor areas, it will be necessary to check weather for rain, fog, dust, heat radiation, which may influence not only the equipment set-up and functioning, but also the outcomes, increasing artifacts and noisy data, and the scanning effective range.

- **Technology definition:** this step concerns the decision about the device and the technology to be used. Sometimes this choice is dictated by external considerations, as budget or availability. However, the features of the planned scanning may suggest choosing a device and/or a technology instead of another one, so this step interacts with the previous one. For example, the operator may choose among Time-of-Flight (TOF) scanners for long-range acquisition, Phase-based scanners for short-range acquisition, and Triangulation ones for small and medium-sized objects.
- **Repository design and creation:** in this step the repository is designed according to the project needs. The project may use an existing repository, if the work concerns models that are added to previously existing ones.
- **Field operations:** this step includes defining the scan position and resolution, the type and number of marks/targets and their position. Each scanner position and orientation angles must be defined according to a local or global site coordinate system. Indoor areas or places (caves, museums etc.) may require the set-up of a lighting system, so the position of every light must be decided and recorded, especially when RGB capture is expected. Some scanners are provided with a built-in digital camera; others use an external digital camera that must be set too. Depending on the object, marks are placed on the object to support the subsequent step called registration. An optimal choice of the marks as regards type (paper, spherical, cylindrical, retro-illuminated and prism) and an accurate recording of their position (using a GPS and/or a Total Station) are crucial to accuracy, as is the scanner Field-of-View (FOV) which together with the object size determines how many scans are taken and need to be registered. Carrying out field operations will follow the design described above. Any change from the planned modality needs to be recorded.
- **3D data registration:** as usually it is not possible to scan the object in one scanning step, the separate models obtained with scanning must be assembled in one complete model, availing of common parts which are made to coincide. These may consist in marks placed on the original as easily recognizable points, or images of the object [7]. The registration process also uses the scanner position, previously recorded, or reconstructed using three Ground Control Points (GCP), with the so-called 'indirect registration' [10]. Registration may also be performed without marks (so-called cloud-to-cloud-based registration), but usually this procedure reduces the accuracy of the overall dataset. A pre-registration cleaning is carried out, cleaning the range maps from noisy data and cleaning the borders of each scan, affected by the error of incidence of the laser beam on the surface (mixed edge effect). The parameters of this cleaning stage must be recorded as well.
- **3D data post-processing:** this includes all the final operations carried out on the model. The outcomes of the registration process are used as point cloud to generate different outcomes, or processed with different software. After registration, the

point cloud is used to generate a polygonal mesh, by connecting the points in order to create a surface. Before, the point cloud needs to be edited for meshing. Cleaning filters are applied to the point dataset in order to clean up all the noisy and redundant information and edit RGB color. Overlap reduction is also used to move the range maps for a better registration. All these process can be done both manually and automatically. For the creation of the polygonal mesh the Poisson Surface Reconstruction [11] and the Delaunay Triangulation [10] are two of the most common algorithms used to create triangulated meshes from point clouds. All the processing is based on parameters chosen by the operator. Finally, decimation and resampling, particularly suited for 3D model visualization on the web, may be applied, creating a lower resolution model. RGB editing and texture mapping is the final step of the pipeline in order to obtain a photorealistic 3D model.

The above-described pipeline is represented in the diagram below.

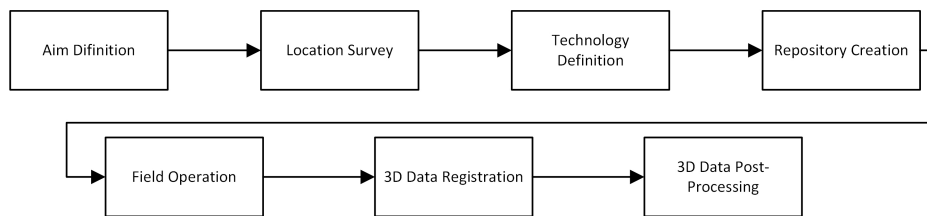

3 Documenting the planned production workflow.

In this section we will outline the documentation system of the abovementioned pipeline using CRMdig. The current version is still a draft, testing it in a number of practical examples. Codes in parentheses refer to entities (E) and properties (P) of CIDOC-CRM; while (D) and (L) refer to CRMdig. The overall digitization project is modeled as a D28 Digital Documentation Process consisting of different activities, those forming the production workflow. The diagrams below describe each activity separately, those represented with a dotted border being referred elsewhere in the model.

3.1 Aim Definition

The step is modeled as the creation (E65) of a document (E31) documenting the digitization aim definition, with the participation (P11) of users (E39).

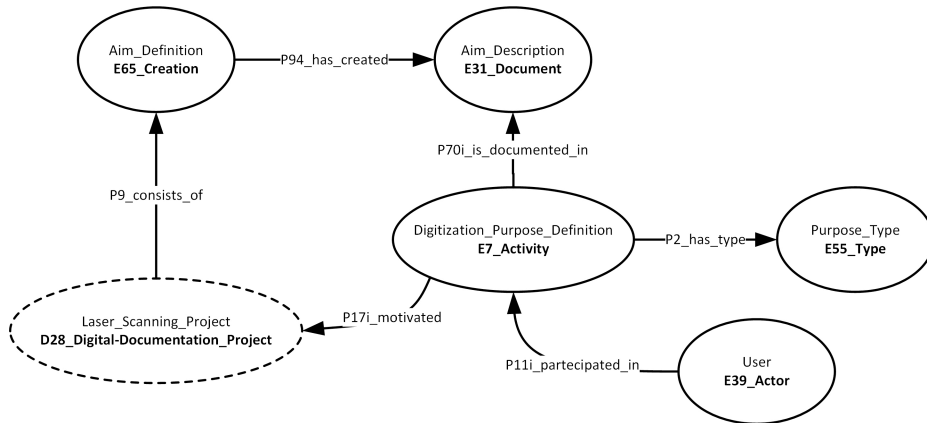

Fig. 1. Aim Definition

3.2 Location Survey

The Location Survey is modeled as an activity (E7), influencing (P15) the choice of the technology to be used. This activity consists of (P9) the Inspection of the Object, of the Site and of an Assessment of the Site Conditions. The Object Inspection is a Creation (E65) of a Document (E31) documenting the Object (E19 Physical Object) to be digitized. The Site Inspection also is a Creation (E65) of a Document (E31). The Place (E53) where the survey takes place (P7) is the same where the Object and its surroundings – the ‘scene’ – is located. The location property P54 has been chosen because it is intended that the scene is a sort of immovable background. The last component of the survey activity is the Assessment (E13 Attribute Assignment) assigning (P141) a Condition State (E3) to the scene via a P44 condition property.

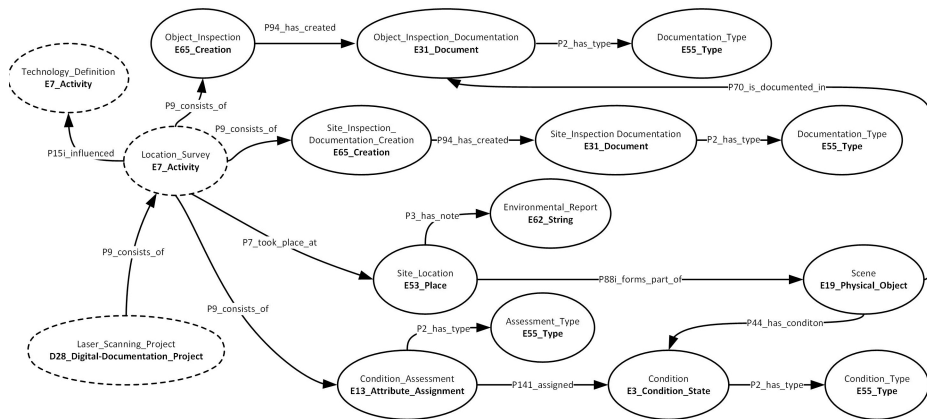

Fig. 2. Location Survey

3.3 Repository Creation

The step consists in the design and creation (P9) of the Repository (D13 Digital Information Carrier) storing the models (D15.Repository Object).

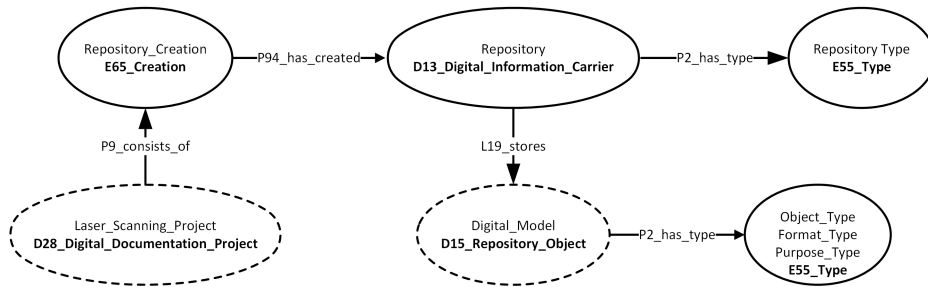

Fig. 3. Repository Creation

3.4 Technology Definition

This step consists of several sub-steps, addressing the different devices to be used in the digitization. It also includes, as specific purpose (P20), the Data Capture Designing (E65), creating (P94) the Digitization Plan (E29).

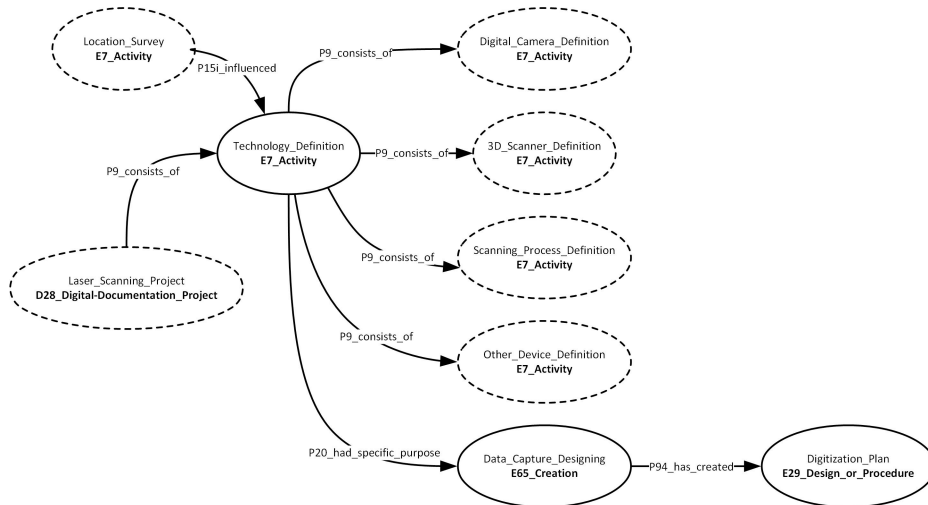

Fig. 4. Technology Definition

Digital Camera Definition. The camera settings are the parameters used (L13) in the Capture Event (D7 Digital Machine Event), altogether considered as a Digital Object (D1), with the values documented via the Event's Dimension (E54). The camera (D8

Digital Device) type collects all its features, and the lenses (E22) type, incorporating their features including the focal length.

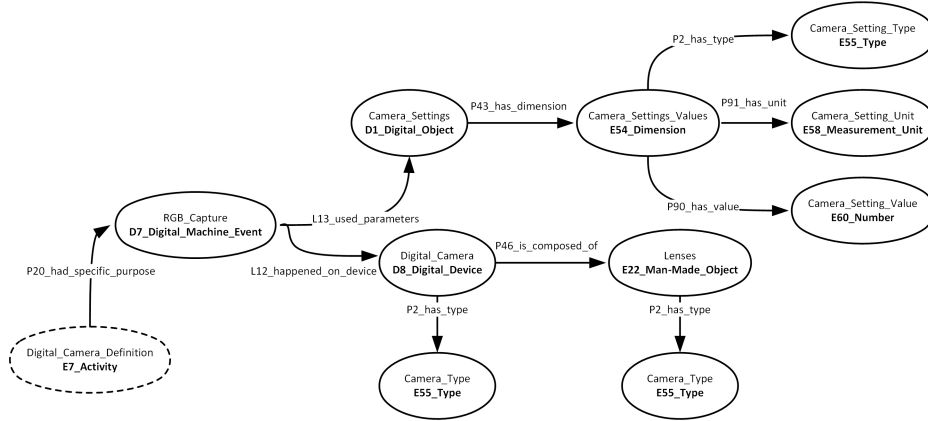

Fig. 5. RGB Capture

Scanner settings. The 3D data capture is modeled in a very similar way, through a Data Capture (D7) Event, which used (L13) parameters (D1) having a Dimension (E34) storing all the necessary information. The type of the Scanner (D8 Digital Device) on which the digitization happens (L12) is recoded separately.

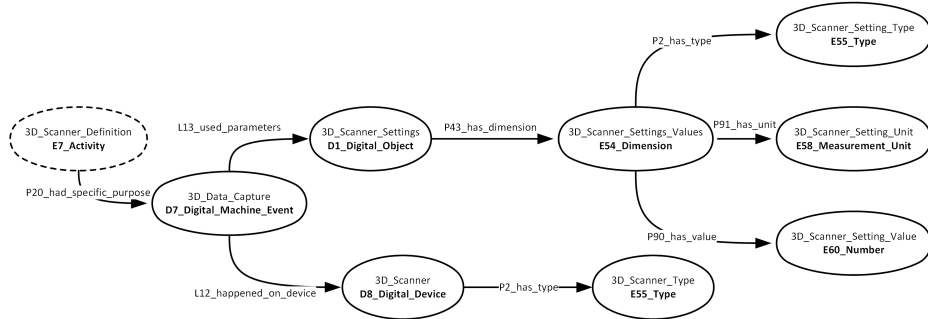

Fig. 6. Scanner Settings

Other Devices. Other devices include equipment for georeferencing the scene and the markers, as a GPS and a Total Station. The structure of their information is very similar to the scanner one and is omitted for space reasons.

3.5 Field Operations.

Field operations concern the creation of a reference network of Marks (E19). Their placement is motivated (P17) by the Scanning Procedure (E29) and the position is recorded through the Measurement (E16) of their Spatial Coordinates (E47).

3.6 Registration (Complete Registration)

Recording the parameters used in the Complete Registration process, modeled as a D7 Digital Machine Event, concerns both the Pre-Registration Cleaning (E9 Formal Derivation) that picks (L21) a model from the (D15) Repository and returns (L22) it there after processing; and the Registration (D10 Software Execution) that takes in input (L10) several models from the Repository (D15) and outputs there (L11) the assembled model. Parameters are modeled as Digital Objects (D1), stored via an E54 Dimension and the related type/unit/value as in the previous cases.

3.7 Post-processing

Post-processing is modeled as a D3 Formal Derivation that picks (L21) a Model from the Repository (D15) and returns (L22) it back after processing. It uses (L23) some software (D1) with has (L13) settings and parameters modeled as usual via E54 Dimension and then type/unit/value.

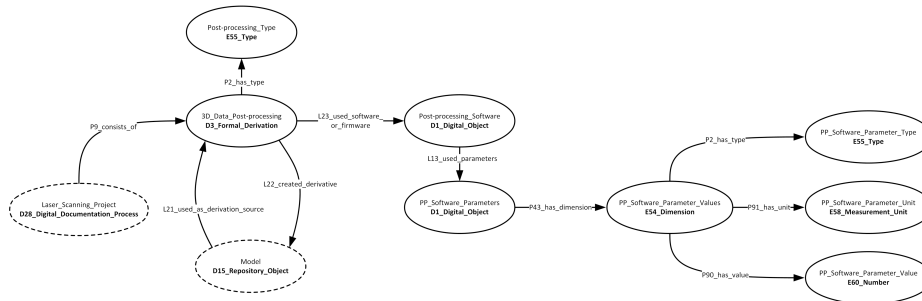

Fig. 7. Post-processing

4 Conclusions and Further Work

With the present paper we have explored how the CRM may support Quality Management, and the conclusion is encouraging. The proposed model may need revision and refinement dictated by practice and perhaps may suggest the definition of shortcuts, such as a simpler way to assign values to parameters. Implementation will need tools to simplify the work.

The CRM had, in the past, the bad reputation of being complicate mainly because of the lack of comfortable input tools for systems based on it. Initial experiences with scanner operators have shown a sort of annoyance for recording all these data. As

already noted in 3D COFORM, equipment producers are instead to blame, because they do not provide any information about the device settings, as is done, for instance, in the EXIF file for 2D data capture. Nevertheless, many of the recording tasks may be easily automated designing an intelligent input interface.

5 Acknowledgements

This paper has been partially supported by the European Commission through the ARIADNE project.

References

1. 3D ICONS: <http://www.3dicons-project.eu>
2. 3D-COFORM: <http://www.3d-coform.eu>
3. The London Charter: <http://www.londoncharter.org>
4. Bryan P., Blake B., Bedford J., 2009, Metric Survey Specifications for Cultural Heritage, English Heritage Publishing.
5. Barber D., Mills J., Andrews D., 2011 3D Laser Scanning for Heritage. Advice and guidance to users on laser scanning in archaeology and architecture, English Heritage Publishing, Swindon.
6. Barber D., Mills J., Bryan P., 2004, Towards a standard specification for terrestrial laser scanning of Cultural Heritage, in XXth ISPRS Congress: Proceedings of Commission V, Istanbul, Turkey.
7. Hiremagalur J., Yen K. S., Akin K., Bui T., Lasky T. A., Ravani B., 2011, Creating Standards and Specification for the Use of Laser Scanning in Caltrans Projects, AHMCT Research Center, Davis, USA.
8. Europeana Regia D5.3 Quality Management, pp. 29-31.
<http://www.europeanaregia.eu/en/project-europeanaregia/project-documentation>
9. Doerr, M., Theodoridou, M.: CRMdig: A Generic Digital Provenance Model for Scientific Observation. In: TaPP 2011, Heraklion (2011)
10. Lerma J. L., Van Genechten B., Heine E., Quintero M. S., 2008, 3D RiskMapping – Theory and practice on Terrestrial Laser Scanning, Editor Universidad Politecnica De Valencia, Valencia, Spain.
11. Kazhdan M., Bolitho M, Hugues H., 2006, Poisson Surface Reconstruction, Symposium on Geometry Processing, Cagliari, Italy, pp. 61-70.