

Decision-making logic in operational emergency situations for hierarchical systems management

Liubomyr Sikora^{1,†}, Nataliia Lysa^{1,*,†}, Olga Fedevych^{1,†} and Yurii Lysyi^{2,†}

¹ Lviv Polytechnic National University, 28a Bandery Str., Lviv, 79000, Ukraine

² Ukrainian Academy of Printing, 19 Pid Goloskom Str., Lviv, 79000, Ukraine

Abstract

The article considers the mathematical and systematic apparatus for describing structures with subsystems and systems with decomposition with the corresponding functional links in the form of operators.

In the analysis of literature sources, it is substantiated that the problem of managing complex systems is not fully solved under the influence of structural, informational, psychological threats, and the problem of structuring the system as a basis for the formation of targeted decisions by operational personnel under active threats is relevant in the future.

The mathematical and systematic apparatus for describing structures with a set of relevant interconnected components is presented. The functional blocks of the system with the corresponding functions and characteristics such as functional transformations, cascade connection in the technological structure, models of adaptive and multiplicative interaction, systems with feedback and hybrid connections and mathematical operations are presented.

A method for risk assessment in management decision-making in hierarchical systems under extreme conditions, taking into account the cognitive components of operators, has been developed.

Keywords

emergency situation, system, management, logic, risk assessment

1. Introduction

Systems analysis arose as a result of attempts to apply the methods and tools of systems theory to solve problems of managing complex hierarchical systems in normal and emergency modes. With the development of man-made structures, information barriers arose, which formed complex management tasks [1, 24]:

- increased bandwidth of data transmission channels and rapid growth of their heterogeneity and blurring;

IntelliTISIS'2024: 5th International Workshop on Intelligent Information Technologies and Systems of Information Security, March 28, 2024, Khmelnytskyi, Ukraine

* Corresponding author.

† These authors contributed equally.

✉ lssikora@gmail.com (L. Sikora); lysa.nataly@gmail.com (N.Lysa); olha.y.fedevych@lpnu.ua (O. Fedevych), llusuy@gmail.com (Y.Lysyi)

ORCID: 0000-0002-7446-1980 (L. Sikora); 0000-0001-5513-9614 (N.Lysa); 0000-0002-8170-3001 (O.Fedevych); 0009-0000-1734-2814 (Y. Lysyi)



© 2023 Copyright for this paper by its authors. Use permitted under Creative Commons License Attribution 4.0 International (CC BY 4.0).

- the complexity of the problems to be solved exceeded the ability to process data flows by humans and the processor of the automated control system (technologic process).

This led to the creation of information systems (as a tool for improving the validity and efficiency of decision-making management) and information technologies for synthesizing strategies for achieving goals, tactics, and system planning of actions at the facility.

In the process of solving complex problems, there are the following levels of hierarchies [1]:

- the hierarchy of the lower level of the object's structure in terms of modules and units;
- hierarchy of the n-th order control structure depending on the target orientation and the level of information processing (sensors, processing units, image formers of dynamic situations);
- hierarchy of the decision tree and division of the target space into clusters.
- hierarchy of priorities in the procedures for ranking alternatives in the target space.
- hierarchy in the construction of sets of goal trees and corresponding classes of strategies and evaluation of their effectiveness relative to the reference way of goal realization.

At this point, this work will investigate some aspects of mathematical and logical basis for hierarchical systems management.

2. References analysis

Books [2, 21] substantiate the problem of integrating methods of situational analysis and causal diagrams of the impact of factors on the management process.

Work [3] consider the problems of management quality and methods of risk assessment in information and control systems.

Books [4, 5, 23] consider logical and cognitive methods and their use in the process of training operational management personnel for all levels of the hierarchy of integrated management of production structures, and substantiate their effectiveness.

Works [17, 18, 22] consider the problem of improving the quality of control processes in complex systems with a hierarchical structure, intellectualization of situation control, knowledge features of decision-making, synthesis of robust control strategies, cognitive features of the ACS operator's thinking process, complex models of energy-active facilities management in the face of threats and information attacks.

Monograph and work [6, 7, 14] substantiate information and logic-cognitive technologies for the implementation of control processes in the face of active threats and terminal emergencies.

Works [8, 9, 13] consider the problem of cybersecurity based on logical and cognitive methods, information and intelligent technologies for processing data flows and event scenarios in infrastructure, taking into account the level of risks using categorical models for representing the organization of complex man-made industries.

In [10] substantiate information technologies for developing methods to ensure the cognitive stability of operational management processes for personnel at all levels of the hierarchy of complex systems.

Works [11, 16] considers the categorical models of representation of the complex systems structure and their effectiveness in forming strategies in infrastructure in case of internal and external conflicts.

In [12], information technologies for identifying the structure of systems, cognitive methods for assessing situations when factors affect the management process and increasing sustainability are developed.

Works [15, 19, 20] substantiate the influence of the cognitive characteristics of operational personnel in the implementation of management in extreme situations, assessing the level of threats at the terminal intervals of formation and decision-making for targeted management, and risk assessment in case of errors in strategic decisions.

3. Main research description and results

Important in the procedure for finding a way to solve problems is the acquisition of data and a model for identifying knowledge in an active diagnostic and expert mode, identifying their logical and cognitive structure [1].

The next step is to isolate the control object from the environment of the technogenic system, and define its boundaries, functional and information structure [1], build a formalized model, assess its adequacy, identify limit and emergency modes and, accordingly, observability and controllability.

The responsible procedure is the object aggregation scheme and the construction of a mathematical model of the hierarchy of the resource and information components of the system in the form of a scheme for structuring relations (linkage matrix, graphs, Petri nets) [1], the Saaty model, and the n-level model for assessing local and global priorities.

At the same time, there are hierarchies of the forward and reverse process [1]:

Table 1

Hierarchies of the forward and reverse process

A direct process of planning the future	Reverse process as a management program
Macro objectives	Desired scenarios for achieving the goal
Factors	Problems and the possibility of realizing local goals
The strength of the factors	Operators and teams
Operators	Team goals
Operator's goal	Team policy
Team policy	Team strategy in the goal achievement program
Contrasting scenarios	-
Generalized scenario of events leading to the required result	-
The course of events and the system's implementation of the trajectory towards the goal	Action plan to achieve the goal and its implementation

The next stage is the hierarchy of procedures for streamlining the stages of action planning and structuring the management system in accordance with the global goal [2,8].

The following stages are carried out in accordance with the global goal [2,9]:

- systematic analysis of the problem and its formalization, identification of critical zones in the space of goals and states of the object;
- decomposition of the problem and construction of scenarios of possible events;
- selection of means to achieve the goal, both local and global, and appropriate scaling of the goal space for its structuring;
- methods and models for assessing the situation in the system as the main means of identifying the information structure of processes in the system and the logic of decision-making;
- identification of logical contradictions in the processes of decision-making and assessment of dynamic situations;
- taking into account causal relationships in the scenario of events and building categories as a way to display information structures;
- building strategies for coordinating team actions and assessing the level of their interaction under risk;
- analysis of the degree of coordination of their actions in the context of the implementation of the action plan and ways to resolve conflicts at all levels of the integrated hierarchical automated control system (IHACS);
- development of coordination strategies based on the information and regulatory framework and construction of appropriate algorithms, with justification of their logical structure.

In accordance with the current situation, let's describe hierarchical structures as an organization for the implementation of targeted tasks, taking into account active attacks and threats and the cognitive component of the operator.

3.1. Mathematical and systematic apparatus for describing structures

Definition. A subsystem S' of a system S will be any subset of $S' \subset X \times Y$, and an element of systems will be a set of appropriately connected components by which the system $S = (S_1 \dots S_n)$ can be restored.

Definition. Definition. A decomposition of a system S is a set of $(S_1, S_2, \dots S_n)$, for which $S = (S_1 + S_2 + \dots + S_n)$ and $X = (X_1 \times X_2 \times \dots \times X_n)$, $Y = (Y_1 \times Y_2 \times \dots \times Y_n)$, are components of the system.

Functional relationships in the system are described in the form of operators.

3.1.1. The system components connections design operator

For two given systems $S_1 \subset X_1 \times Y_1$ and $S_2 \subset X_2 \times Y_2$, a design operator is introduced defining the structure similarity class, whose representation is as follows:

$$\begin{aligned} \Pi r_1: (X_1 \times X_2) \times (Y_1 \times Y_2) &\rightarrow (X_1 \times Y_1), \\ \Pi r_2: (X_1 \times X_2) \times (Y_1 \times Y_2) &\rightarrow (X_2 \times Y_2) \end{aligned} \quad (1)$$

Accordingly then it is possible to carry out an independent decomposition S into two subsystems of unrelated type:

$$\begin{aligned}
 S &\subset (X_1 \times X_2) \times (Y_1 \times Y_2), \\
 S_1 &= \text{Pr}_1(S) \text{ and } S_2 = \text{Pr}_2(S), \\
 \text{Pr}_1: (X_1, X_2, Y_1, Y_2) &= (X_1 \times Y_1), \\
 \text{Pr}_2: (X_1, X_2, Y_1, Y_2) &\rightarrow (X_2 \times Y_2).
 \end{aligned} \tag{2}$$

with state spaces, control objects (OU_i), control systems (SU_i), information structures (IS_i), and mode parameters (Y_i).

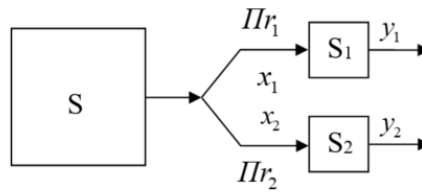

Figure 1: Connections design operator.

3.1.2. The operator of systems cascade decomposition and their functional organizations

The decomposition procedure is the basis for the allocation of functional blocks with appropriate characteristics and functions.

Π1 – functional transformations $f : X \rightarrow Y$ that define resource, technological, and measurement transformations, executive team actions, and one-step operations.

Π2 – cascade connection in the technological unit structure, information and measurement

$$\left. \begin{aligned}
 S_1 : X_1 &\rightarrow Y_1 \rightarrow \\
 &\rightarrow S_2 : (Y_1^* \oplus Y_2^*)
 \end{aligned} \right\} \text{SitPi}$$

operations

Π3 – model of additive and multiplicative interaction in the course of technological and information operations:

$$\begin{aligned}
 (X_1, X_2) &\rightarrow (S_i) \rightarrow Y_i \\
 S_i: (X_1 \otimes X_2) &\rightarrow Y_i \\
 S_i: (X_1 \oplus X_2) &\rightarrow Y_i
 \end{aligned} \tag{3}$$

Π 4 – system structure with feedback (information, control).

Π 5 – a combination of structural components with hybrid feedback.

Π 6 – blocks for performing mathematical operations in information and management subsystems.

Any system $S \subset X \times Y$ allows decomposition in the form of a cascade structure if the conditions [5, 6] for the functions are met.

The decomposition of the system infrastructure provides an appropriate representation for displaying technological processes, information and control operations, and representation of threat factors and information attacks.

In accordance with the structures, let's distinguish functional operational elements (Fig. 2):

1. Transformation of material and energy resources (units, power units) into a product ($M_R \rightarrow A_T(M_R) \rightarrow PR_T$);
2. Transformation of data flows into an information resource based on data processing operations $\{D_i\} \rightarrow A_I(\{D_i/T_m\}) \rightarrow I(D_i)$;
3. Transformation of information resource and data flows into a cognitive knowledge structure for interpreting the content of the situation $(\{D_i\}, (I(D_i))) \xrightarrow{T_i} A_{cognt}(I(D_i)) \xrightarrow{T_i} \text{Sens} [\text{Sit}(t, T_i)]$.
4. Transformation of intellectual and information resource into management actions based on goal-oriented strategies $\text{Sens} [\text{Sit}_{ou}(t_t, T_t)] \xrightarrow{\text{StratU}} (C_i) \rightarrow D_i(U_i/C_i)$

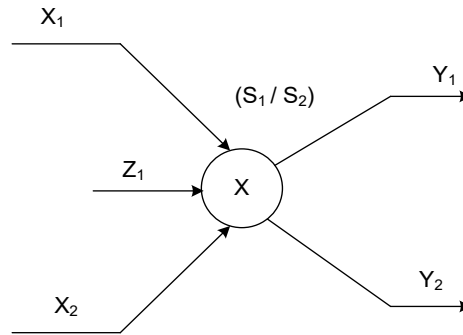

Figure 2: Cascade decomposition operator.

According to the components of the structure, dynamics models are formed.

$$\begin{aligned} ((x, x') \in E_x) &\Leftrightarrow S(x) = S(x') \\ ((y, y') \in E_y) &\Leftrightarrow (y)S = (y')S \end{aligned} \quad (4)$$

with canonical representations of transformations in the form of a chain of information and control operations:

$$\boxed{(x \rightarrow [S] \rightarrow y) \rightarrow \left(x \rightarrow [Y_x]^{x/Ex} \rightarrow [S']^{y/Ey} \rightarrow [Y_y^{-1}] \rightarrow y \right)} \quad (5)$$

accordingly, the transformation coordinates of state parameters will be set according to the control actions:

$$\begin{aligned} Y_x: X &\rightarrow X/Ex \\ Y_y: Y &\rightarrow Y/Ey \end{aligned} \quad (6)$$

$([y], y) \in Y_y^{-1} \Leftrightarrow [y] = Y_y(y)$ - determine the transformation of the parameters of the state spaces of the system S when management actions affect the object and then $U_i: X_i(t_i) \rightarrow U_i(t_i + \tau_j, U_i) \in V(t_i + \tau_i)$ - output state.

3.1.3. Autonomy of functional systems that are part of a hierarchical organization structure

In the informational sense, decision-making in the autonomous functioning of the system is achieved by introducing feedback, which provides a logical structure for the decision-making process. The decision-making logic is based on [1, 2, 7]:

1. detecting the difference between the real and target trajectories in the state space of the power-active object and control system;
2. assessment of the degree of difference object state trajectories;
3. classification of trajectory differences based on the division of the goal space into alternative areas (NORMA, ALARM, AVAR);
4. assessment of the situation according to the classification and synthesis of control actions, according to the strategies for achieving the goal, which ensures access to the target area of management systems in the face of threats.

Let's consider some aspects of the systems' functionality.

3.1.4. The concept of complex systems functionality (categorical models of structures) by Mesarovych

Consider a system $S \subset (X \times Z_3) \times (Y_1 \times Z_4)$ whose feedback loop link includes the element $S_f \subset (Z_y \times Z_x)$. Accordingly, the condition $[(X, Z_x, Y, Z_y) \in S] \Rightarrow [Y = Z_y], Z_y \in Z_y \subset Y$ is fulfilled for the system, and the system is defined in $(X \times Z_x) \times Y$ space.

The structure of the feedback control system is represented as follows (Fig. 4).

Let's define additional properties of feedback systems according to [3]:

1. A functional system $F_s(S_f): X \rightarrow Y$ is mutually unambiguous if a number of conditions are met in terms of structure, goals, strategies:
2. a) the condition of the target functionality $(F_{ci}): [\exists S_f: (Y) \rightarrow Z_x] \Rightarrow (S_f \vartheta F_s(S_f))$ - functionality;
3. b) the functionality of the systems is determined according to the goals $((X, Z, Y) \in S) \vartheta ((X', Z, Y) \in Z) \Rightarrow (X = X')$ - unambiguity.
4. The system $S \subset (X_1, x \dots x, X_n)$ is functionally controlled if the condition of goals alignment with the structure and strategies is met:
5. $(\forall y \in Y)(\exists x \in X)((x, y) \in S) \rightarrow \exists \left(StrukSU, Strat \left(U/C_i \right) \right)$
6. A multidimensional system will be autonomous as a result of feedback closure only if the condition of structural and information-management resilience against the impact of complex threat factors (additive and multiplicative models) is met.

Accordingly, a description of the dynamic state will be the next:

$$\begin{aligned}
 &\forall S(S \subset (X_1, \dots \times X_n) \times Z_x \times (Y_1, \dots \times Y_n)) \\
 &\exists S_f(S_f \subset (Y_1, \dots \times Y_n) \times Z_x), \text{ if} \\
 &F(S_0 \square S_f) = (S_1 + S_2 + \dots + S_n),
 \end{aligned}
 \tag{7}$$

where $S_i \subset (X_i \times Y_i)$ - functionally controlled in the state space and the target space.

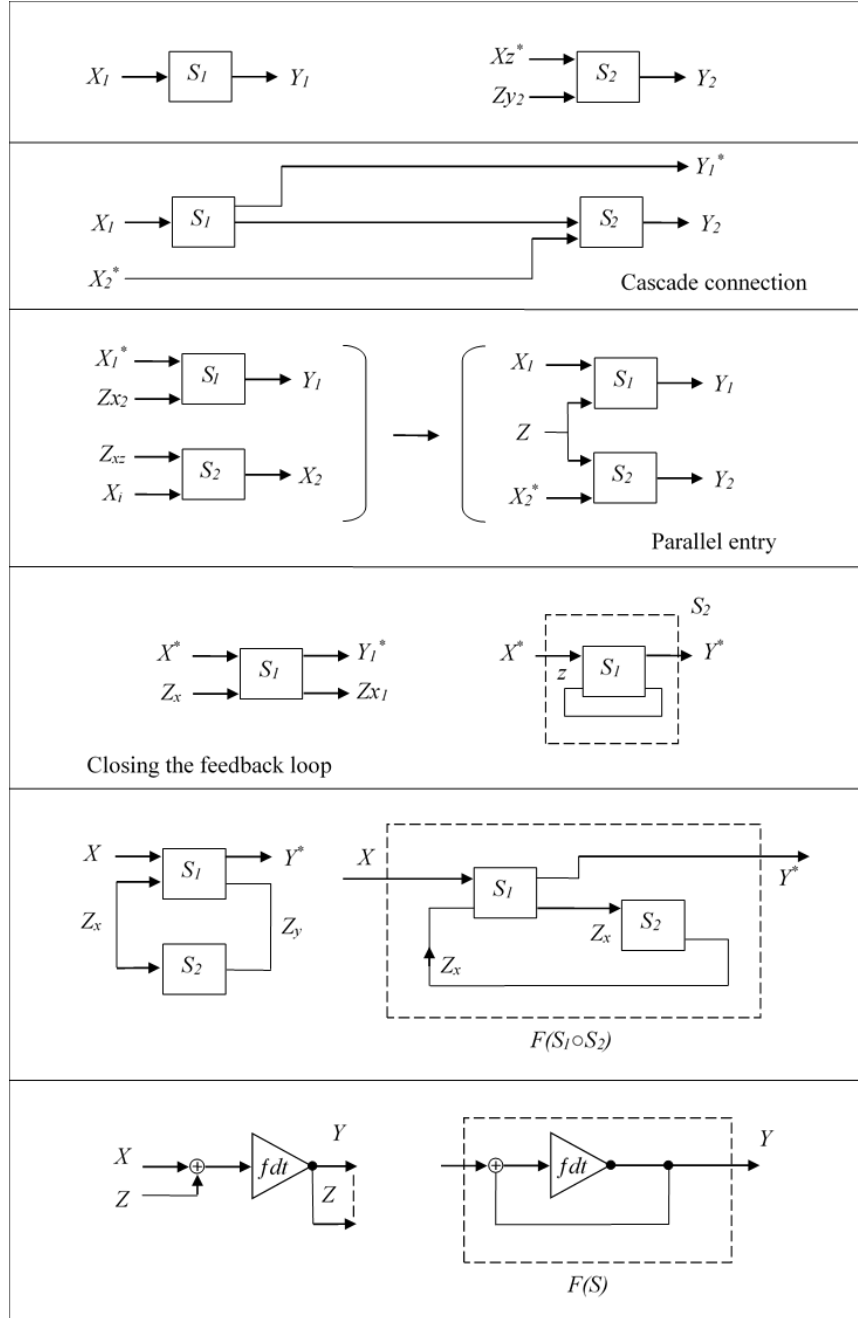

Figure 3: Basic structural components of system aggregation.

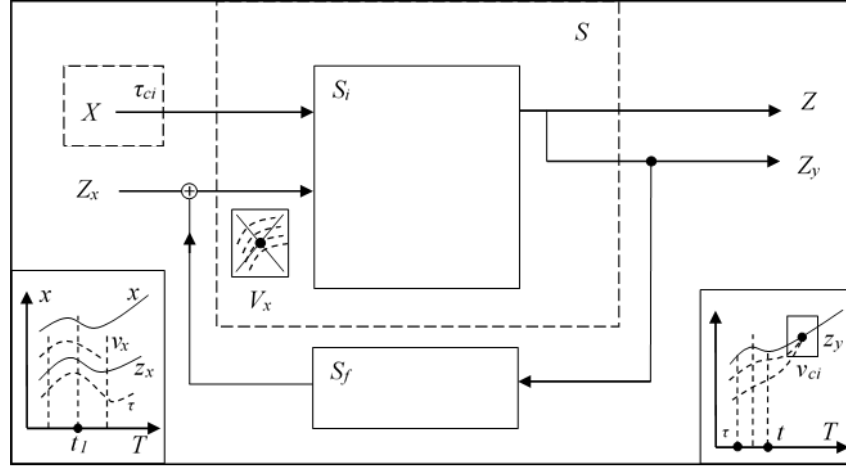

Figure 4: Structure of the system with feedback.

The concept of autonomy means that after the introduction of feedback, each component of the output signal $\{y_i\}$ can be changed only after changing the input action $\{x_i\}$, while the output $y_i, j \neq i$ the control action does not affect the change in the state of the system with the target strategy [4].

The functional controllability of the system means that an appropriately selected input control action ($X/U/\text{Start } U(C_i)$), according to the target control strategy, can bring the system to the target area V_{C_i} , i.e.

$$\forall F_i(t_i) \exists (U_i): \exists \text{Start } (U_i/C_i); \exists X \equiv U_i; U_i: X \rightarrow Y_i \in V_{C_i} \rightarrow [SitNORMA].$$

Autonomous operation of the energy-active system.

If S is a multidimensional functional system

$$S: (X_x Z_z) \rightarrow Y, X = (X_1 \times \dots \times X_n) \text{ and} \\ Z_x = (Z_{x_1} \times \dots \times Z_{x_n}), Y = (Y_1 \times Y_2 \times \dots \times Y_n),$$

then there is a feedback given in the form of the structure S_f , then it is autonomous and represented in the form of a parametric $(X^n \times T)$ description

$$(\forall y \in Y)(\exists (X \times X_x)); (X \times Z_x) \Rightarrow (y = S(x, z)), \quad (8)$$

where $S_f: Y \rightarrow Z_x$ is the substructure that ensures the autonomy of the system.

To implement the operation of mixing the input signal with the feedback signal, the element H is introduced, which is an operation $A_H(+, -, K_n)$ of positive and negative feedback and implements the input stage of the system with feedback (Fig. 5), which represents the dynamics of changes in the state trajectory (y is a parameter, $y(t_i) \in Y, t_i \in T_m$) of an energy-active object due to the impact of threats or information disorientation on the control process.

In accordance with the target task, a structural diagram of an automatic tracking system with information feedback is formed, which transmits signals of changes in the state of the object under the influence of the input control signal and interference with the functioning of the control object (Fig. 5):

$$[X \otimes (Z - V_n)] \rightarrow (S_o) \rightarrow (Y_i, Z_i) \rightarrow (\text{State}) \\ V_K = [A(S_t) \otimes Z_i] \rightarrow (\text{shifting... trajectory})$$

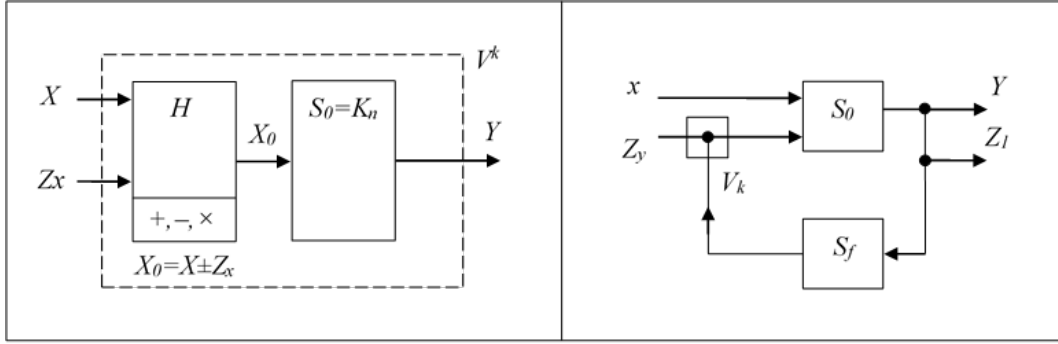

Figure 5: Structure of the system with feedback.

To ensure functional stability, the trajectory stabilization condition is met according to the specified conditions:

$$\begin{aligned}
 & (\forall x \in X, \forall x_0 \in X_0, \exists z \in Z_x): [X_0 = H(x, z)], \text{ and} \\
 & [H(x, z) = H(x', z)] \Rightarrow (x = x'), \\
 & [H(x, z) = H(x_1, z'_1)] \Rightarrow (z = z'), \\
 & \forall \hat{y}, \exists (\hat{x}, \hat{z}): (\hat{y} = (H \square S_0)(\hat{x}, \hat{z})), \\
 & \forall \hat{y}, \exists (\hat{X}_0): (\hat{y} = S_0(\hat{X}_0)).
 \end{aligned}$$

3.1.5. Terminal dynamic systems of energy-active class

Terminal dynamic T_m - systems are functional and, due to the internal development of control actions, are determined on the basis of a representation in the form of a logical structure [14,15,16]:

$$\forall t, \forall x, X\hat{x}, (X/\bar{T}^t = \hat{X}/\bar{T}^t) \Rightarrow (S_0(x)/\bar{T}^t = S_0(\hat{x})/\bar{T}^t), \quad (9)$$

that is (S_0/\bar{T}^t) , the system is functional $\forall t \in \bar{T}^t$.

For such systems, the unambiguity of functionality is determined in accordance with the condition of management sustainability and adequacy of the structure to the goals:

If $\exists S, S \subset (x \times Z_x) \times Y$ - the system, then according to goals $\exists \text{strat } U/C_i \exists S_f, S_f \subset (Y \times Z_x) \vartheta F(SOS_f) = F_s(S_f)$ determines that is functional and unbiased, then the trajectory equation has the form:

$$\forall z \in T, (\exists (x, y, z) \in S) \vartheta ((\hat{x}, \hat{y}, \hat{z}) \in S) \vartheta ((z, y) | \bar{T}^z = (\hat{z}, \hat{y}) | \bar{T}^t) \Rightarrow (x | \bar{T}^t = \hat{x} | \bar{T}^t) \quad (10)$$

and the system $F_s(S_f) | \bar{T}^t$ is unambiguously functional.

For hierarchical systems, the condition of unambiguous functioning of all systems ensures the functional stability of the structure; if such conditions are violated, the system will experience limit and emergency modes, structural collapse, loss of controllability, and disasters. For the functional controllability of the required system, it is enough to make the system $(S = H \square S_0)$ autonomous with the help of a communication loop Sf.

Based on the above analysis of the structure and functionality of hierarchical systems and the impact of external and internal threats on control modes, there is a draw of conclusion about the training of operational personnel and their knowledge.

The modern development of the science of intelligence is based [4] on three aspects of cognitive functioning that were not taken into account in the IQ-concept, respectively: competence (conscious knowledge base); pragmatism of thinking procedures; mental potential for problem solving.

The blocks of knowledge necessary for performing professionally oriented activities are formed in the process of learning and work based on the ordering of the knowledge acquired in the past and the amount of new knowledge.

Gradation of stages of knowledge accumulation:

1. quality of school education as a basis for professional orientation;
2. technical education (vocational schools, colleges, workshops);
3. engineering and university education in the area of specialization of each student;
4. professional activity in the chosen field and assessment of compatibility with the requirements for efficiency and responsibility;
5. professional work of the highest rank, understanding of the independence of training, internships, doctoral studies for strategic level positions.

In accordance with the stages of knowledge accumulation, let's build a table of information and cognitive suitability of operational personnel (Table 2).

Table 2
Information and cognitive fitness of operational personnel

#	Cognitive fitness index	KF	α_{risk}
1	Ability to perform active management actions (ZAd)	0.55-1.5	$\alpha_r < 0.2$
2	Focused on recognizing the situation (CSitIIS)	0.85-1.5	$\alpha_r < 0.25$
3	Impact of active attack factors and threats (Rek (AF))	0.65-1.5	$\alpha_r < 0.5$
4	Correlation to goal-oriented activities under the influence of threats (CDi))	0.75-1.5	$\alpha_r < 0.3$
5	Multiple targeted alternatives for action selection (C(Di))	0.95-1.5	$\alpha_r < 0.25$
6	Developing a strategy to eliminate threats (VStrarU)	0.85-1.5	$\alpha_r > 0.5$
7	Cognitive selection of sequential actions to target and eliminate attacks (KSv(Ci))	0.75-1.5	$\alpha_r > 0.5$
8	Targeted selection of a course of action during an attack IISv(Ci)	0.85-1.5	$\alpha_r < 0.2$
9	Conscious risk assessment in case of life threat α_{risk}	0.75-1.5	$\alpha_r < 0.25$
10	Formation of consistent actions in the system under the influence of threats (FIcon Sit)	0.65-1.5	$\alpha_r > 0.5$
11	Choosing a way to counteract information attacks and understanding the nature of the situation (Sens (Icon))	0.75-1.5	$\alpha_r > 0.5$
12	Understanding the essence of the image of the target situation in attacks (Sens (Ci))	0.75-1.5	$\alpha_r > 0.5$
13	Active counteraction in case of threats to the targeted operations (Di(Ci/Ui))	0.55-1.5	$\alpha_r > 0.5$

14	Operator confidence in their actions ($K_V.sp$)	0,85-1,5	$\alpha_r > 0.2$
15	Comprehensive operator confidence and intelligence ($S_g K_V(A_i) Zp K_V(A_j)$)	0,7-1,5 0,65-1,5	$\alpha_r > 0.2$ $\alpha_r > 0.3$
16	Operator confidence in their knowledge ($SK_V(A_i)$)	0,85-1,5	$\alpha_r > 0.5$
17	Professional self-confidence of the operator ($S_Z K_V(A_i)$)	0,85-1,5	$\alpha_r > 0.7$
18	Trust of external experts in the identity of the operator ($R_d(A_i)$)	0,25-1,5	$\alpha_r > 0.5$
19	Professional credibility of a cognitive agent ($K_{ZP}(A_i)$)	0,25-1,5	$\alpha_r > 0.5$
20	Self-confidence in the ability to solve the problem ($K_{cogn}(A_i) K_{du}(A)$)	0,75-1,5 0,85-1,5	$\alpha_r > 0.8$
21	Determination to act in the face of risk ($K_d(D_{risk})$)	0,85-1,5	$\alpha_r > 0.75$
	$K_d(D(Ci))$	0,95-1,5	

where (α_{risk})- risk assessment, (K_d) - cognitive trust coefficient, (K_V) - coefficients of knowledge requirements.

4. Conclusion

The article considers certain aspects of the use of logical and intellectual procedures that form the basis of the scheme for synthesizing hierarchical control systems.

Based on the construction of hierarchical systems with different functional structure, an approach using the logic of actions and the theory of situational management is proposed, models of the structure of systems for active control of technological processes under conditions of dynamic disturbances, both systemic, structural and cognitive-informational types, are developed.

The concept of goal orientation and coordination of the logical and cognitive model of forming control decisions of a system with a hierarchical structure under conditions of threats and information attacks as a basis for the synthesis of robust decision-making strategies in crisis emergency situations is substantiated.

References

- [1] K. Kendall, J. Kendall, Systems Analysis and Design, 10th ed., Prentice Hall, New York, NJ, USA, 2020.
- [2] B. Durniak, R. Tkachuk, O. Mashkov O., L. Sikora, N. Lysa, Information and Logical-Cognitive Technologies for Training Operational Personnel to Work in Terminal Emergencies, UAP PH, Lviv, Ukraine, 2022. (In Ukrainian)
- [3] J. Henly, H. Kimamoto, Reliable Technical System Design and Risk Assessment, High School, Kyiv, Ukraine, 1987.
- [4] G. Boy, The Handbook of Human-Machine Interaction: A Human-Centered Design Approach. 2st ed. , CRC Press, Boca Raton, FL, 2017. doi: 10.1201/9781315557380
- [5] T. Aven, S. Thekdi, Enterprise Risk Management: Advances on Its Foundation and Practice, 1st ed. Routledge, London, UK, 2019. doi: 10.4324/9780429425028
- [6] D. Stirzaker, Stochastic Processes and Models, Cambridge University Press, Cambridge, UK, 2016. doi: 10.1017/CBO9781316576532

- [7] J. O'Connor, I. McDermott, *The Art of Systems Thinking: Essential Skills for Creativity and Problem Solving*, Thorsons, London, UK, 2018.
- [8] K. Vellani, *Strategic Security Management: A Risk Assessment Guide for Decision Makers*, 2st ed., CRC Press, Boca Raton, FL, USA, 2019.
- [9] V. Khoroshchko, B. Bobalo, V. Dudykevych, *Procurement of Integrated Information Security Systems*, NU LP PH, Lviv, Ukraine, 2020. (In Ukrainian).
- [10] M. Groover, *Automation, Production Systems, and Computer-Integrated Manufacturing*, 5th ed., Pearson, London, UK, 2018.
- [11] B. Durniak, L. Sikora, M. Antonyk, R. Tkachuk, *Cognitive Models of Formation of Strategies for Operational Management of Integrated Hierarchical Structures in Conditions of Risks and Conflicts*, Ukrainian Academy of Printing PH, Lviv, Ukraine, 2013. (In Ukrainian).
- [12] J. Girdhar, *Management information systems*, New Delhi Oxford University Press, New Delhi, India, 2013.
- [13] D. Tattam, *A Short Guide to Operational Risk*; 1st edn. Routledge, London, UK, 2011. doi: 10.4324/9781315263649
- [14] R. Watt, *Visual Processing: Computational, Psychophysical, and Cognitive Research: Computational Psychophysical and Cognitive Research*; 1st edn., Psychology Press, London, UK, 1988; doi: 10.4324/9781315785080
- [15] M. Wiggins, *Introduction to Human Factors for Organizational Psychologists*; CRC Press, Taylor & Francis Group, Boca Raton, FL, USA, 2022. doi: 10.1201/9781003229858
- [16] P. Yu, *Multiple-Criteria Decision Making: Concepts Techniques and Extensions*; Plenum Press, New-York-London, USA-UK, 1985 doi: 10.1007/978-1-4684-8395-6.
- [17] H. Yousef, *Power System Load Frequency Control: Classical and Adaptive Fuzzy Approaches*, CRC Press, Boca Raton, FL, USA, 2017. doi: 10.1201/9781315166292
- [18] P. Melin, O. Castillo, *Modelling, Simulation and Control of Non-Linear Dynamical Systems: An Intelligent Approach Using Soft Computing and Fractal Theory*, CRC Press, Boca Raton, FL, USA, 2019. doi: 10.1201/9781420024524
- [19] V. Bhise, *Decision-Making in Energy System*, CRC Press, Boca Raton, FL, USA, 2022. doi: 10.1201/9781003107514
- [20] H. Jantan, A. Hamdan, Z. Othman, *Intelligent techniques for decision support system in human resource management*, *International Journal of Innovative Computing, Information and Control*, 7(1) (2011)13-24. doi: 10.5772/39401
- [21] A. Nejad, *Fundamentals of System Analysis & Design* Publisher, LAP LAMBERT Academic Publishing, Saarbrücken, Germany, 2014. doi:10.13140/2.1.1469.7280
- [22] S. Demri, V. Goranko, M. Lange, *Temporal Logics in Computer Science*, Cambridge University Press, Cambridge, UK, 2016. doi: 10.1017/CBO9781139236119
- [23] I. Goodfellow, J. Pouget-Abadie, M. Mirza, B. Xu, D. Warde-Farley, S. Ozair, A. Courville, Y. Bengio, *Generative adversarial nets*, *Advances in neural information processing systems*, 27 (2014) 2672–2680. doi: 10.48550/arXiv.1406.2661
- [24] E. Manziuk, *Intelligent information technology for obtaining trust decisions based on the ontology of trust using a human-centered approach*, *Computer Systems and Information Technologies*, 1 (2022), 83-88. doi: 10.31891/CSIT-2022-1-11 (In Ukrainian).