

INSTRUCTION BOOK FOR
Lace And Grommet
Theater-Type Screens



Pre-Installation

Da-Lite Lace and Grommet screens are custom made to meet the requirements for large surface installation of a relatively permanent nature. Great care is taken in the production of these screens to assure extreme serviceability and excellence of picture reproduction. Maximum overall size is based on fabric type.

The Lace and Grommet screen may be ordered in the fabrics listed below - all of which are flame retardant and mildew resistant. Trimmed with a strong 2-1/2" webbing and grommets spaced uniformly every 6 inches. Lacing cord, included at a slight extra charge, is laced through grommets and fastened to hooks on frame. . . providing a completely wrinkle-free surface. No frames are furnished, but suggestions for their construction are provided on page 3.

Lace and Grommet style screens are not recommended unless the stage has a fly loft for safe storage of the screen when it is not in use.

Screens are priced per square foot on overall screen sizes, which are 5" larger each way than picture area. When ordering Lace and Grommet custom made screens, please give the following dimensions:

1. Overall size, including black webbing.
2. Net picture area, excluding black webbing.

Approximate shipping weight, 1/2 lb. per square foot.

Large projection screens will have one or more vertical seams.

Choose from these famous surfaces:

| | |
|---------------------------|-----------------------------|
| Matte-White | Cinema Vision |
| High Contrast Matte White | High Contrast Cinema Vision |
| Glass Beaded | High Contrast Cinema Perf |
| Pearlescent | Dual Vision |
| Da-Mat | Video Spectra® 1.5 |
| High Contrast Da-Mat | Silver Matte |
| Da-Tex (Rear) | Audio Vision |
| High Power | High Contrast Audio Vision |
| Silver Vision | |

Manufacturer's Precaution

Each Da-lite Screen is carefully inspected, wrapped and packed in a manner that insures delivery to destination in first class condition. Careless handling of screens during installation can

result in screen surface being wrinkled, torn or damaged. Da-Lite Screen Company does not assume responsibility for such damage.

Suggested Methods Of Installation

Conditions in theaters vary so greatly that no set of instructions would be complete for each theater. The following suggestions, regarding the installation, when supplemented with proper care and good judgment in meeting local conditions will result in a rapid and satisfactory installation.

Installing Screen to the frame: First, and most important, is to handle the screen in a manner to prevent its being wrinkled during installation.

Safest method is to lay the frame flat on a clean floor and unroll the screen inside the frame. Tie it in at all four corners to ensure centering in the frame. Then lacing should be installed around all four sides. Do not attempt to draw lacing tight until after the frame is raised to a vertical position.

When necessary to install the screen to a frame already erected, and one that cannot be taken down, it is necessary to stand the rolled screen on end in front of the frame and tie it at frequent intervals to the top of the frame as it is unrolled.

Before starting the actual lacing, we recommend tying the screen to all four corners of the frame to insure its being spaced properly inside the frame.

Things to Remember: Practically every installation will have its own individual problem. For instance, you may find in using your old frame that it is not large enough to lace the screen on the inside, in which case you would place the hooks on the front and outer edge of the frame. For this purpose we recommend using roofing nails every six inches, leaving one-fourth inch out of the wood for the lacing cord.

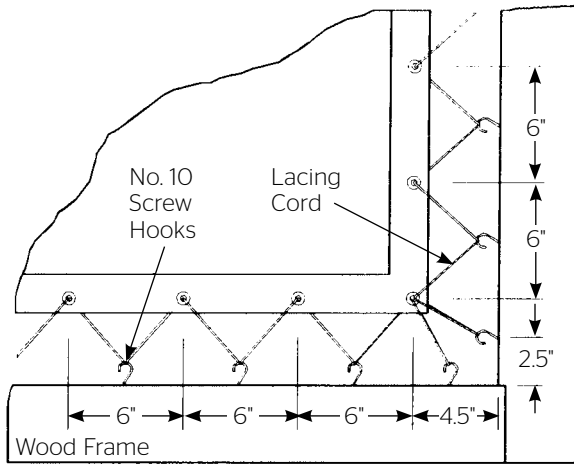

Zig Zag Lacing

Zig Zag Lacing of lacing cord alternately through grommets and under hooks is a method that will produce good results. Use this method where it is necessary to lace a screen to a pipe frame without hooks.

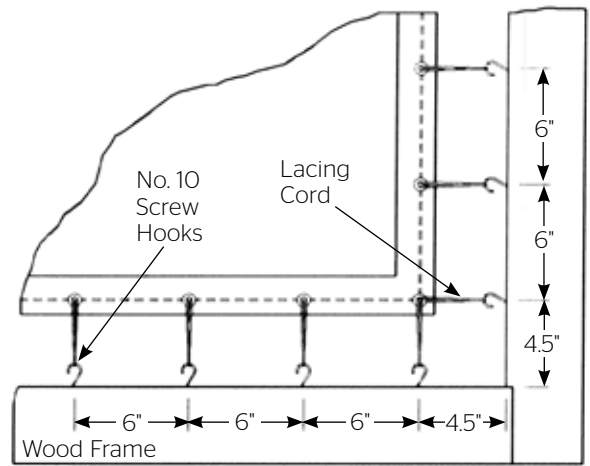

Single Loop Lacing

Single Loop Lacing is fast since each loop is merely doubled, pushed through the grommet and down over the screw hook. Alignment between grommet and screw hook must be straight to avoid puckering of picture surface.

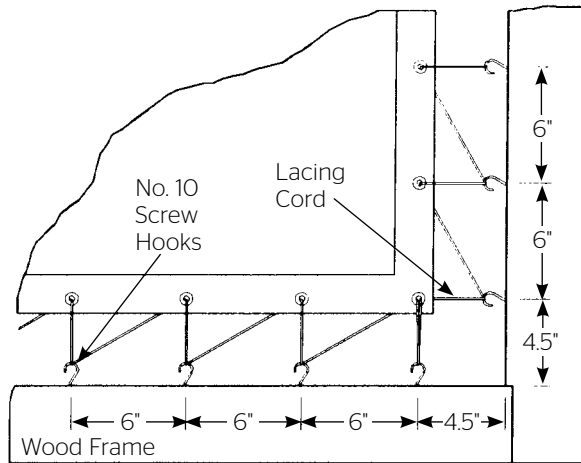

Diagonal Lacing

Diagonal Lacing provides a desirable tension on the fabric. It facilitates putting the correct tension in the correct direction regardless of the grommet and hook relationship.

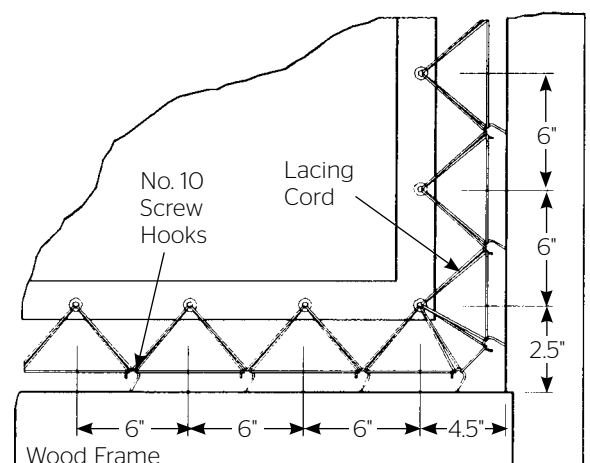

Double Loop Lacing

Double Loop Lacing tends to eliminate any tendency of the picture surface to creep at the edges or unnecessary puckering. This is overcome by pulling each loop over two hooks.

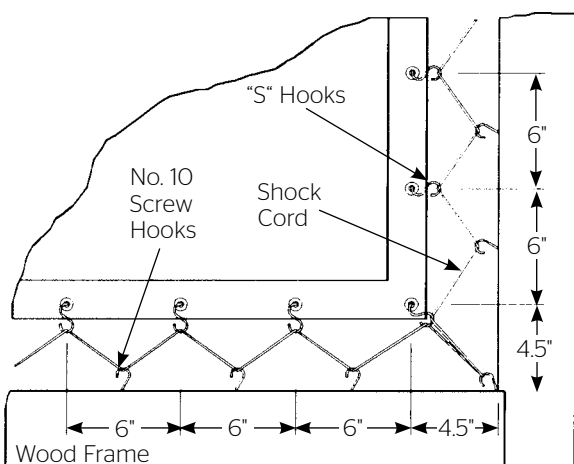

Shock Cord (Elastic) Lacing

Shock Cord Lacing calls for elastic lacing cord (approx. 3/16" dia.) and "S" hooks (approx. 1-1/2") which are inserted in grommet holes. This is the fastest method and usually considered adequate. (Shock cord not supplied by Da-Lite.)

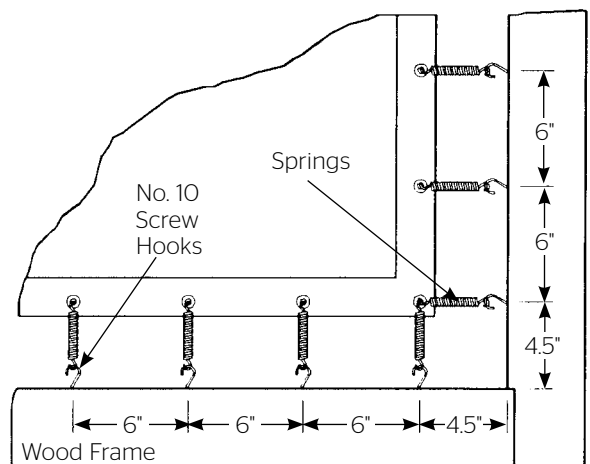

Spring Lacing

Spring Mounting is a more expensive method, usually reserved for rear screens used out of doors. Here grommet holes must be in perfect alignment with the screw hooks. (Springs not supplied by Da-Lite.)

Suggested Screen Frame Building Instructions

NOTE: Inside width and height of screen frame should be 12" greater than picture size or 7" greater than over-all size (including the webbing).

Lumber - Redwood, Spruce, Pine, White Fir. Use 2" x 4" stock for frames to hold screens 11' x 14' or under. Use 2" x 6" stock for screens of larger sizes.

Cutting Lumber - 2" x 4" stock-Cut sides or vertical pieces 1' 8" longer than over-all vertical measurements of screen.

Cut top and bottom or horizontal pieces 1' 3" longer than over-all horizontal width of screen. 2" x 6" stock-Cut vertical pieces 2' longer than over-all vertical measurements of screen. Cut top and bottom of horizontal pieces 1' 6" longer than over-all horizontal width of screen.

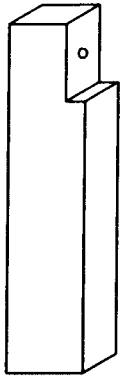

Notching

2" x 4" stock. Notch 2 vertical (shortest) pieces as shown. 2" x 6" stock is notched longer and deeper.

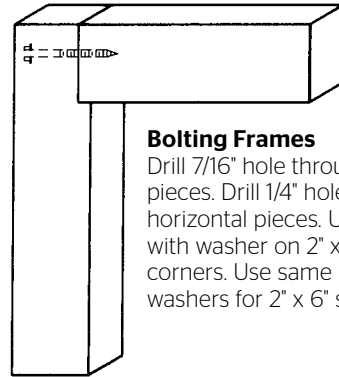

Bolting Frames

Drill 7/16" hole through notched pieces. Drill 1/4" hole into ends of horizontal pieces. Use 3/8" lag bolt with washer on 2" x 4" frames at corners. Use same lag bolts and washers for 2" x 6" stock.

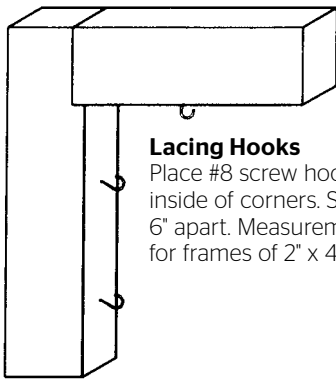

Lacing Hooks

Place #8 screw hooks 4-1/2" from inside of corners. Space all others 6" apart. Measurements are same for frames of 2" x 4" and 2" x 6" stock.

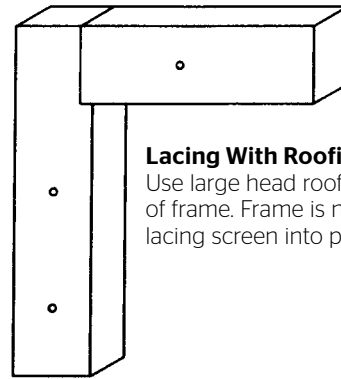

Lacing With Roofing Nails

Use large head roofing nails on face of frame. Frame is now ready for lacing screen into position.

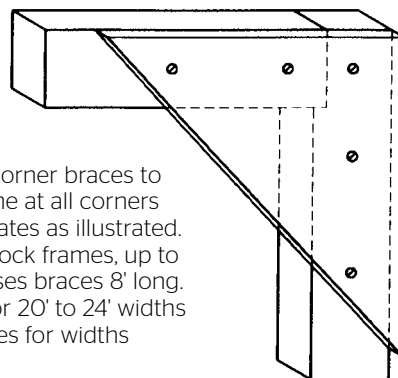

Bracing

Bolt 2" x 4" corner braces to back of frame at all corners or gusset plates as illustrated. On 2" x 6" stock frames, up to 20' width, uses braces 8' long. 10' braces for 20' to 24' widths and 12' braces for widths over 24'.

LIMITED ONE YEAR WARRANTY ON DA-LITE PRESENTATION PRODUCTS

Milestone AV Technologies LLC warrants certain Da-Lite branded products to the original purchaser only, to be free from defects in materials and workmanship for a period of one (1) year from the date of purchase by the original purchaser; provided they are properly operated according to Da-Lite's instructions and are not damaged due to improper handling or treatment after shipment from the factory.

This warranty does not apply to equipment showing evidence of misuse, abuse or accidental damage, or which has been tampered with or repaired by a person other than authorized Da-Lite personnel.

Da-Lite's sole obligation under this warranty shall be to repair or to replace (at Da-Lite's option) the defective part of the merchandise. Returns for service should be made to your Da-Lite dealer. If it is necessary for the dealer to return the screen or part to Da-Lite, transportation expenses to and from Da-Lite are payable by the purchaser and Da-Lite is not responsible for damage in shipment. To protect yourself against damage or loss in transit, insure the product and prepay all transportation expenses.

TO THE MAXIMUM EXTENT PERMITTED BY APPLICABLE LAW, THIS WARRANTY IS IN LIEU OF ALL OTHER WARRANTIES, EXPRESS OR IMPLIED, INCLUDING WARRANTIES AS TO FITNESS FOR USE AND MERCHANTABILITY. Any implied warranties of fitness for use, or merchantability, that may be mandated by statute or rule of law are limited to the one (1) year warranty period. This warranty gives you specific legal rights, and you may also have other rights, which vary from state-to-state. **TO THE MAXIMUM EXTENT PERMITTED BY APPLICABLE LAW, NO LIABILITY IS ASSUMED FOR EXPENSES OR DAMAGES RESULTING FROM INTERRUPTION IN OPERATION OF EQUIPMENT, OR FOR INCIDENTAL, DIRECT, OR CONSEQUENTIAL DAMAGES OF ANY NATURE.**

In the event that there is a defect in materials or workmanship of a Da-Lite product, you may contact our Sales Partners at PO Box 137, Warsaw, IN 46581-0137, (574) 267-8101, (800) 622-3737.

IMPORTANT: THIS WARRANTY SHALL NOT BE VALID AND DA-LITE BRANDED PRODUCTS SHALL NOT BE BOUND BY THIS WARRANTY IF THE PRODUCT IS NOT OPERATED IN ACCORDANCE WITH THE DA-LITE WRITTEN INSTRUCTIONS.

Keep your sales receipt to prove the date of purchase and your original ownership.



A Milestone AV Technologies Brand

3100 North Detroit Street
Warsaw, Indiana 46582
P: 574.267.8101 or 800.622.3737
F: 574.267.7804 or 877.325.4832
E: info@da-lite.com
www.da-lite.com

DL-0270 0114

© 2013 Milestone AV Technologies LLC. Printed in U.S.A.

79160