

Installation Process

Step 1

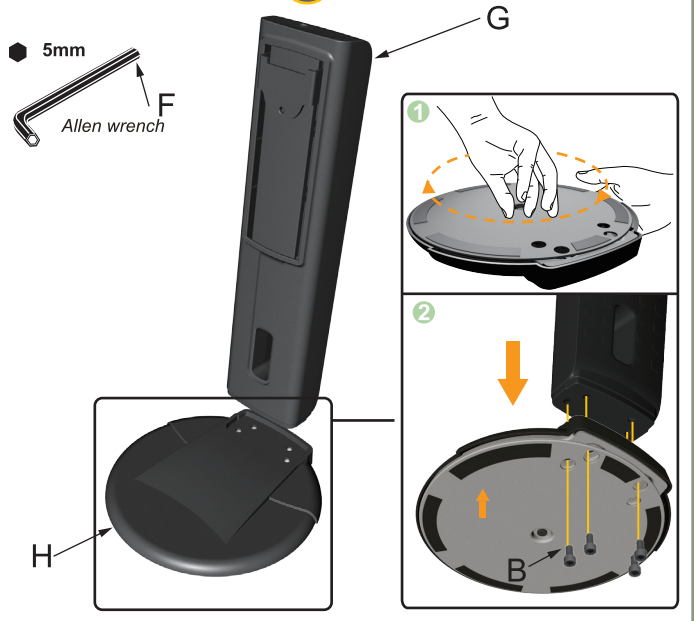

Step 2

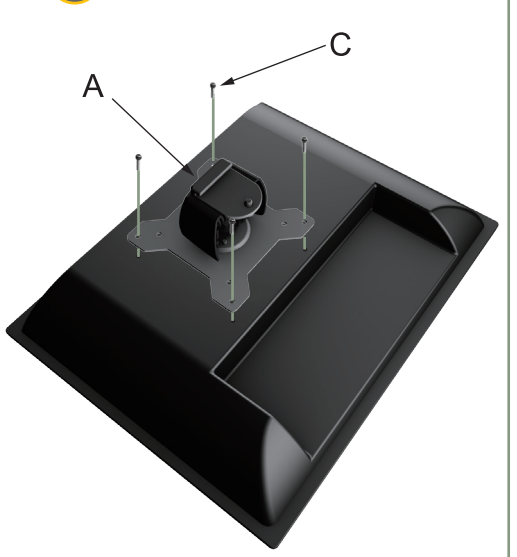

Step 3

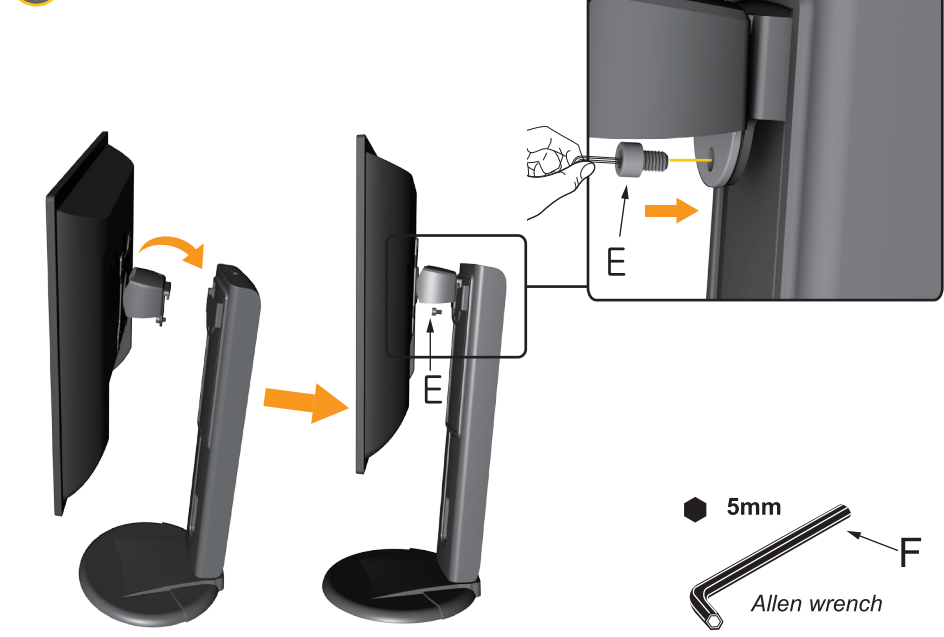

Swivel&Tilt / Rotate

Vertical Adjust

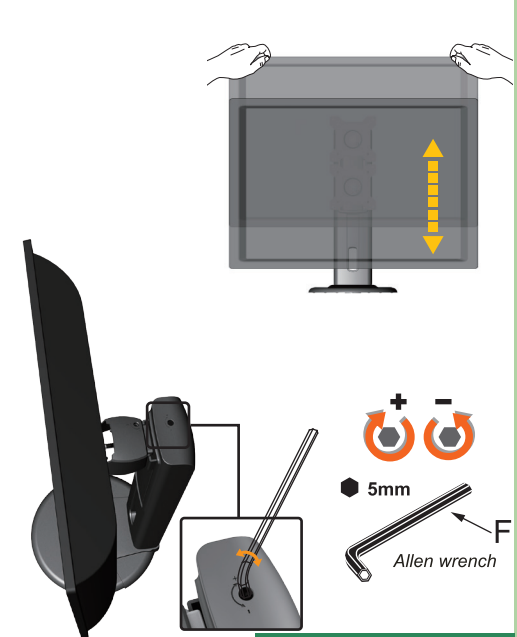

Torque Adjust

Tilt

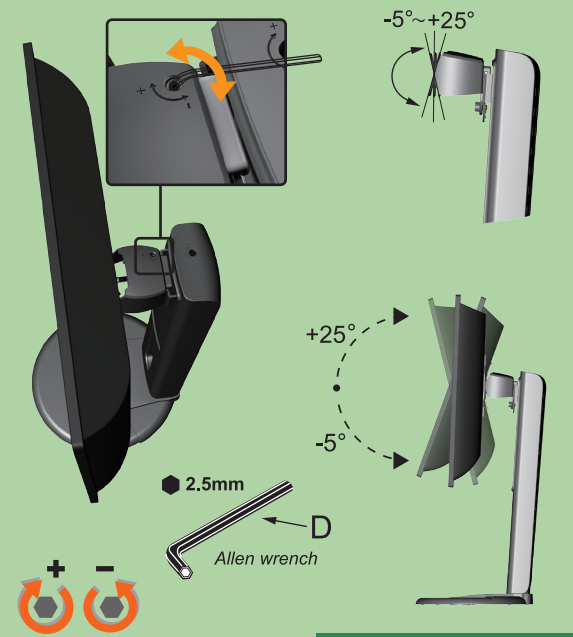

Torque Adjust

Rotate

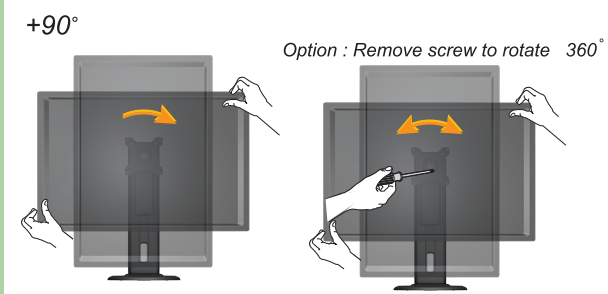

Swivel

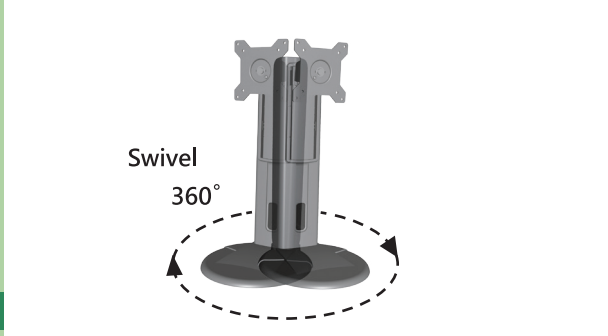

Cable Management

