

---

**RS-232 | RS-422 | RS-485**

**Quad-Port Multi-Interface**

**Ethernet Serial Server**

**Models: ESP904, ESP904E**



---

Manual Documentation Number: ESP904-4513m

B&B Electronics Mfg Co Inc – 707 Dayton Rd - PO Box 1040 - Ottawa IL 61350 - Ph 815-433-5100 - Fax 815-433-5104 – [www.bb-elec.com](http://www.bb-elec.com)  
B&B Electronics Ltd – Westlink Commercial Park – Oranmore, Galway, Ireland – Ph +353 91-792444 – Fax +353 91-792445 – [www.bb-europe.com](http://www.bb-europe.com)





**International Headquarters**

B&B Electronics Mfg. Co. Inc.  
707 Dayton Road  
Ottawa, IL 61350 USA

**Phone** (815) 433-5100 -- **General Fax** (815) 433-5105

Website: [www.bb-elec.com](http://www.bb-elec.com)

**Sales** e-mail: [orders@bb-elec.com](mailto:orders@bb-elec.com) -- **Fax** (815) 433-5109

**Technical Support** e-mail: [support@bb.elec.com](mailto:support@bb.elec.com) -- **Fax** (815) 433-5104

**European Headquarters**

B&B Electronics Ltd.  
Westlink Commercial Park  
Oranmore, Co. Galway, Ireland

**Phone** +353 91-792444 -- **Fax** +353 91-792445

Website: [www.bb-europe.com](http://www.bb-europe.com)

**Sales** e-mail: [sales@bb-europe.com](mailto:sales@bb-europe.com)

**Technical Support** e-mail: [support@bb-europe.com](mailto:support@bb-europe.com)

© B&B Electronics – January 2008

---

Manual Documentation Number: ESP904-4513m

B&B Electronics Mfg Co Inc – 707 Dayton Rd - PO Box 1040 - Ottawa IL 61350 - Ph 815-433-5100 - Fax 815-433-5104 – [www.bb-elec.com](http://www.bb-elec.com)  
B&B Electronics Ltd – Westlink Commercial Park – Oranmore, Galway, Ireland – Ph +353 91-792444 – Fax +353 91-792445 – [www.bb-europe.com](http://www.bb-europe.com)



---

© 2008 B&B Electronics. No part of this publication may be reproduced or transmitted in any form or by any means, electronic or mechanical, including photography, recording, or any information storage and retrieval system without written consent. Information in this manual is subject to change without notice, and does not represent a commitment on the part of B&B Electronics.

B&B Electronics shall not be liable for incidental or consequential damages resulting from the furnishing, performance, or use of this manual.

All brand names used in this manual are the registered trademarks of their respective owners. The use of trademarks or other designations in this publication is for reference purposes only and does not constitute an endorsement by the trademark holder.

---

Manual Documentation Number: ESP904-4513m

B&B Electronics Mfg Co Inc – 707 Dayton Rd - PO Box 1040 - Ottawa IL 61350 - Ph 815-433-5100 - Fax 815-433-5104 – [www.bb-elec.com](http://www.bb-elec.com)  
B&B Electronics Ltd – Westlink Commercial Park – Oranmore, Galway, Ireland – Ph +353 91-792444 – Fax +353 91-792445 – [www.bb-europe.com](http://www.bb-europe.com)



---

# Table of Contents

---

<b>CHAPTER 1: INTRODUCTION.....</b>	<b>1</b>
FEATURES.....	1
COMMUNICATION MODES .....	2
<i>Direct IP Mode</i> .....	2
<i>Virtual COM Mode</i> .....	2
<i>Paired Mode</i> .....	3
<i>Heart Beat</i> .....	3
ESP904 QUICK START GUIDE.....	4
<i>Hardware Setup</i> .....	4
<i>Software Installation</i> .....	4
<i>ESP904 Configuration</i> .....	5
<i>Install Virtual COM Ports on PC</i> .....	6
<i>Check Communications</i> .....	6
<b>CHAPTER 2: MAKING THE HARDWARE CONNECTIONS .....</b>	<b>7</b>
PACKAGE CHECKLIST .....	7
ESP904 CONNECTIONS, INDICATORS AND RESET SWITCH .....	7
<i>Indicator Lights</i> .....	8
<i>Ethernet Connector</i> .....	8
<i>Power Connector</i> .....	8
<i>Reset Button</i> .....	8
<i>Serial Ports</i> .....	9
SERIAL SERVER/PORT OPERATIONAL MODES .....	9
<i>Default Mode</i> .....	9
<i>Console Mode</i> .....	10
<i>Upgrade Mode</i> .....	10
<i>RS-232 Mode</i> .....	10
<i>RS-422 Mode</i> .....	10
<i>RS-485 Mode</i> .....	11
ESP904 SERIAL PORT CONNECTOR PIN-OUTS .....	12
<b>CHAPTER 3: INSTALLING THE VLINX ESP SOFTWARE.....</b>	<b>13</b>
SOFTWARE INSTALLATION.....	13
<i>Automatic Installation</i> .....	13
<i>Manual Installation</i> .....	13
<i>Updating an Existing Installation</i> .....	15
<i>Opening the ESP Manager</i> .....	16

<b>CHAPTER 4: USING ESP MANAGER.....</b>	<b>17</b>
HARDWARE SETUP .....	17
SOFTWARE SETUP.....	18
SOFTWARE OVERVIEW .....	19
<i>Menus.....</i>	<i>19</i>
<i>Server Icons Pane .....</i>	<i>21</i>
<i>Serial Server / Virtual COM Lists.....</i>	<i>21</i>
<i>Status Bar.....</i>	<i>22</i>
SEARCH FOR SERVERS .....	22
CONFIGURE SERVER PROPERTIES .....	23
<b>CHAPTER 5: CONFIGURING THE ESP904 SERVER PROPERTIES .....</b>	<b>27</b>
DESCRIPTION OF THE SERVER PROPERTIES .....	28
<i>Server Name.....</i>	<i>28</i>
<i>Serial Number .....</i>	<i>28</i>
<i>Password.....</i>	<i>28</i>
<i>DHCP .....</i>	<i>28</i>
<i>IP Address.....</i>	<i>29</i>
<i>Netmask.....</i>	<i>30</i>
<i>Gateway .....</i>	<i>30</i>
<i>MAC Address .....</i>	<i>30</i>
<i>Version &amp; Date .....</i>	<i>30</i>
<i>Link Status.....</i>	<i>30</i>
<i>Server Serial Port .....</i>	<i>30</i>
<i>Baud Rate.....</i>	<i>30</i>
<i>Data/Parity/Stop .....</i>	<i>31</i>
<i>Flow Control.....</i>	<i>31</i>
<i>TCP/UDP Protocol.....</i>	<i>31</i>
<i>Serial Timeout.....</i>	<i>32</i>
<i>TCP Alive Timeout.....</i>	<i>32</i>
<i>Connection Mode .....</i>	<i>32</i>
<i>Delimiter HEX 1 and Delimiter HEX 2.....</i>	<i>32</i>
<i>Force Transmit .....</i>	<i>33</i>
<i>Port Status.....</i>	<i>33</i>
<i>TCP/UDP Port.....</i>	<i>33</i>
<i>Serial Port Mode.....</i>	<i>33</i>
<i>Connection At .....</i>	<i>34</i>
<i>Max Connection.....</i>	<i>34</i>
<i>Remote IP Address.....</i>	<i>34</i>
<i>Update/Save.....</i>	<i>34</i>
<b>CHAPTER 6: INSTALLING VIRTUAL COM PORTS .....</b>	<b>39</b>
VIRTUAL COM PORT INSTALLATION .....	39



MATCHING THE ESP904 AND VIRTUAL COM PORT SETTINGS.....	42
<b>CHAPTER 7: REMOVING VIRTUAL COM PORTS.....</b>	<b>45</b>
REMOVING THE VIRTUAL COM PORT WITH ESP MANAGER .....	45
REMOVING THE VIRTUAL COM PORT USING DEVICE MANAGER .....	46
<b>CHAPTER 8: UPGRADING THE ESP904 FIRMWARE.....</b>	<b>49</b>
DOWNLOADING THE FIRMWARE .....	49
UPGRADING VIA ESP MANAGER.....	49
<i>Preparing the Software</i> .....	49
<i>Upgrading the Firmware</i> .....	50
<b>CHAPTER 9: USING CONSOLE MODE .....</b>	<b>51</b>
CONSOLE MODE SETUP .....	51
<i>Navigating the Configuration Menus</i> .....	52
<i>Using a Password</i> .....	53
<b>CHAPTER 10: USING THE WEB SERVER .....</b>	<b>55</b>
SETTING SERVER PROPERTIES .....	55
<b>CHAPTER 11: USING TELNET.....</b>	<b>59</b>
CONFIGURATION USING TELNET .....	59
<i>Navigating the Configuration Menu</i> .....	60
<b>CHAPTER 12: ESP904 TECHNICAL DATA .....</b>	<b>63</b>
<b>APPENDIX A: RS-232 CONNECTIONS.....</b>	<b>67</b>
ESP904 DB-9 PIN-OUTS IN RS-232 MODE .....	67
<i>RS-232 Straight-through Cable Connections</i> .....	68
<i>RS-232 Crossover (null modem) Cable Connections</i> .....	68
<i>RS-232 Crossover DB-9 to DB-25 Conversion Connections</i> .....	69
<i>RS-232 DTE Loopback Connections</i> .....	70
<b>APPENDIX B: RS-422 CONNECTIONS.....</b>	<b>71</b>
ESP904 DB-9 PIN-OUTS IN RS-422 MODE .....	71
<b>APPENDIX C: RS-485 CONNECTIONS.....</b>	<b>75</b>
ESP904 DB-9 PIN-OUT IN RS-485 MODE.....	75
<b>APPENDIX D: NETWORK CONNECTIONS.....</b>	<b>77</b>
STANDARD ETHERNET CABLE RJ-45 PIN-OUT.....	77
CROSSOVER ETHERNET CABLE RJ-45 PIN-OUT .....	78



---

# Chapter 1: INTRODUCTION

---

The **VLINX Model ESP904 Quad-Port Ethernet Serial Server** provides Ethernet to Serial connections for RS-232, RS-422 or RS-485 devices. The serial ports can be accessed over a LAN/WAN using **Direct IP Mode**, **Virtual COM Port**, or **Paired Mode** connections. The 10/100 Mbps Ethernet connection auto-selects 10BaseT or 100BaseTX and indicates the type of connection with a bi-color link light.

## Features

- **4 multi-interface serial ports** - RS-232, RS-422, RS-485; software selectable connections
- **10/100 Mbps Ethernet** with Auto Selection
- **LAN and WAN Communications**
- **TCP or UDP Client or Server operation** - configurable
- **Software Support** - Windows 98/ME/2000/2003/NT 4.0/XP and Vista
- **Firmware Upload** for future revisions/upgrades
- **Configuration** of Ethernet and serial port settings can be accomplished using any of four methods:
  - **VLINX ESP Manager Software for Windows** allows configuration via a network connection or directly from the Ethernet port of a computer (using an Ethernet crossover cable).
  - **Web Server** allows configuration via the network using any web browser.
  - **Telnet** allows configuration via the network by accessing the setup configuration menu.
  - **Console Mode** allows configuration through an RS-232 serial port in using a VT100 Terminal Emulation program and an RS-232 crossover cable.
- **Virtual COM Driver Software for Windows** - installs a virtual COM port, viewable in the Windows Device Manager under **Ports (COM & LPT)**. Virtual COM port provides access to any of the ports on the ESP904, like any other serial port (legacy, PCI, USB or PCMCIA) on the computer. Any program running on the computer and using Windows-based COM ports can access the serial devices attached to the

ESP904. The LAN becomes transparent to the serial device and the software running on the PC.

- **Heart Beat Connection** - selectable protocol ensures reliable communications in Virtual COM Port or Paired Connection modes. This feature restores the connections if communications are temporarily lost at either end due to loss of power or the Ethernet connection.

## Communication Modes

The **ESP904** enables communication with serial devices over a LAN or WAN. Serial devices no longer are limited to a physical connection to the PC COM port. They can be installed anywhere on the LAN using TCP/IP or UDP/IP communications. This allows traditional Windows PC software access to serial devices anywhere on the LAN/WAN network.

### Direct IP Mode

**Direct IP** connections allow applications using TCP/IP or UDP/IP socket programs to communicate with the asynchronous serial ports on the ESP904. In this type of application the ESP904 is configured as a TCP or UDP server. The socket program running on the PC establishes a communication connection with the ESP904. The data is sent directly to and from the serial port on the server. When using UDP protocol the server can be configured to broadcast data to and receive data from multiple IP addresses.

### Virtual COM Mode

Use **Install Virtual COM** to add a driver, to provide a virtual COM port on the computer. The new COM port shows up in the Device Manager. Windows programs using standard Windows API calls are able to interface to virtual COM ports. When a program on the PC opens the new COM port, it communicates with the remote serial device connected to one of the ports on the ESP904.

After connection, the LAN is transparent to the program and serial device. Applications are able to work just as if the serial device is connected directly to a physical COM port on the computer. The virtual COM port software converts the application's data into IP packets, sends it across the network to the ESP904, which converts the IP packet back to serial data and sends the data out a serial port located on the ESP904.

---

To use this mode, the ESP904 must be set to either TCP/server or UDP/server with a designated communication port number. The virtual COM driver is the TCP or UDP client.

## **Paired Mode**

**Paired Mode** is also called serial tunneling. In this mode any two serial devices that can communicate with a serial link will be able to communicate using two ESP904s and the LAN.

Two ESP904s are connected to a network, one configured as a TCP or UDP client and the other as a TCP/UDP server. When setting up the server the remote IP address section must contain the address of the client. This will allow the client's IP address to pass the IP address-filtering feature of the server. Conversely, the Remote IP address of the client must contain the server's IP address. Both communication port numbers must be the same.

## **Heart Beat**

The **Heart Beat** protocol connection provides a reliable communications connection in **Virtual COM Port Mode** or with **Paired Connection Mode**. This feature restores the connection if communications are temporarily lost at either end due to loss of power or Ethernet connection.

Without this feature a device that loses a connection and stops communicating would not be able to reconnect without human intervention. A TCP data connection can be lost when there is a power failure or temporary loss of an Ethernet connection on either the client or server. If a loss occurs the Heart Beat feature will try to reconnect the TCP data connection every five seconds until communications is established again. The Heart Beat feature is available for use in **Virtual COM Port Mode** and **Paired Connection Mode**. This is not available when using a UDP application.

# ESP904 Quick Start Guide

For descriptive purposes this Quick Start Guide considers a typical configuration consisting of a **PC** connected via an Ethernet LAN to an **ESP904 Serial Server** connected to the RS-232 port of a **serial device**.

## Hardware Setup

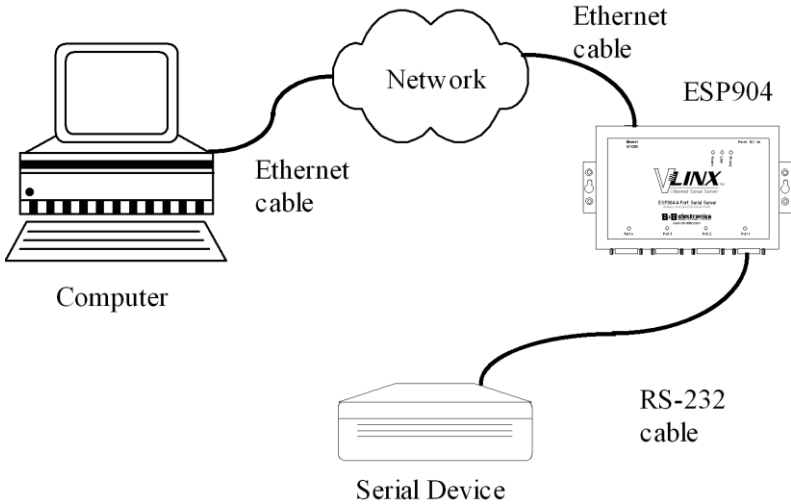

Figure 1. Quick Start Hardware Setup

**Step 1:** Connect the ESP904 to the network using a standard network cable

**Step 2:** Connect the ESP904 to the RS-232 serial device.

**Note:**

*If the serial device is configured as a DCE use a straight-through serial cable. If the serial device is configured as a DTE use a crossover (null modem) cable.*

**Step 3:** Apply power to the **Serial Server**.

## Software Installation

Using the CD included with the ESP904, install the **VLINX ESP Manager** software on the configuring computer.

## ESP904 Configuration

**Step 1:** Open the **ESP Manager** software. It will automatically search for any reachable (ESP90x) **Serial Servers**. A list of all **Serial Servers** connected to the LAN will appear in the **Serial Server List** window.

**Step 2:** Double click the first ESP904 port on the list (4000) to bring up the **Server Properties** configuration screen.



Figure 2. The Server Properties Window

**Step 3:** Change the **Server Properties** as required.

- Enable **DHCP** to allow the ESP904 to generate its own IP address

**OR**

- Obtain appropriate static **IP**, **Netmask** and **Gateway** addresses from your Network Administrator (recommended)
- Set the **Console Mode** property to RS-232 to match the serial device connected to the ESP904 serial port 1.
- Set **Baud Rate**, **Data/Parity/Stop**, and **Flow Control** to match the configuration of the serial device connected to the ESP904 serial port

**Step 4:** When the parameters have been set, click **Update**. Following the prompts in the dialogue boxes, **Restart** the Serial Server and **Search all reachable servers** again.

**Step 5:** Re-enter **Server Properties** to verify the changes have taken effect, or to view/change the configuration of other ports. Each port must be configured separately.

## Install Virtual COM Ports on PC

- Step 1:** From the **Windows Start** menu, run the **Install Virtual COM Ports** utility included with the VLINX software,
- Step 2:** Search for all servers on the network
- Step 3:** Select the first port (4000) and map it to an unused COM port (e.g. Port 15). Configure it for TCP protocol and the appropriate IP address (determined in the last section).

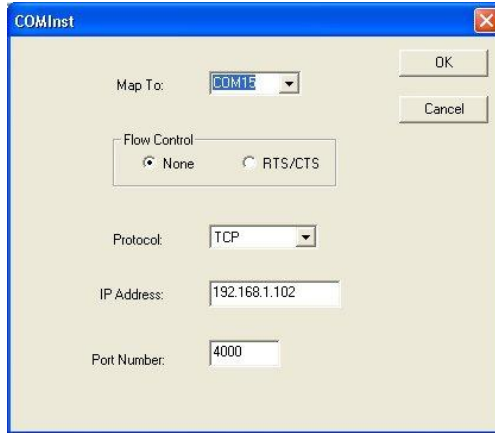

Figure 3. Configuring the Virtual COM Port

## Check Communications

- Step 1:** From the **Windows Start** menu, run **HyperTerminal**
- Step 2:** Configure **HyperTerminal** to connect using the COM port configured in the last section (e.g. Port 15).
- Step 3:** Set **Baud Rate**, **Data/Parity/Stop**, and **Flow Control** to match the configuration of the serial device connected to the ESP904 serial port.
- Step 4:** Communications with the serial device should now be operational.



---

# **Chapter 2: MAKING THE HARDWARE CONNECTIONS**

---

## **Package Checklist**

The **ESP904 4-port serial server** is shipped with the following items included:

- ✓ ESP904 Serial Server Module
- ✓ Power supply
- ✓ This manual
- ✓ CD-ROM disc with manual, VLINX ESP Manager and Virtual COM Driver software for Windows 98/ME/2000/2003/XP/NT 4.0/Vista

## **ESP904 Connections, Indicators and Reset Switch**

The ESP904 has:

- Seven indicator LEDs
- One Ethernet connector
- A power connector
- A recessed reset switch
- Four serial port connectors

## Indicator Lights

Light	Indication
Power	<b>Red</b> - power is applied
Link	<b>Yellow</b> – 10BaseT Ethernet connection established <b>Green</b> – 100BaseTX Ethernet connection established
Ready	<b>Flashing Green</b> – system is ready
Serial (4)	<p><b>When set up as a TCP server:</b></p> <p><b>Steady Green</b> - client has made a connection, communications starting</p> <p><b>Flashing Green</b> – data present at serial port</p> <p><b>Light off</b> – connection closed</p> <p><b>When setup in UDP mode:</b></p> <p><b>Steady Green</b> (all ports)</p> <p><b>Flashing Green</b> – data is being transmitted</p>

## Ethernet Connector

The **ESP904** has a standard RJ-45 receptacle mounted in the top edge of the chassis. The ESP904 can be connected to an Ethernet hub, switch, or wall plate using a standard straight-through RJ-45 (male) Ethernet cable. To connect directly to an RJ45 Ethernet port on a PC or laptop a crossover Ethernet cable must be used.

**Note:**

Refer to Appendix D for details on Network Cables

## Power Connector

Plug the ultra-miniature phone plug from the included power supply into the power jack and then plug the supply in. When power is applied the Red power light will illuminate. The tip of the power plug is positive; the sleeve is negative.

## Reset Button

This switch resets the unit, similar to the effect of removing/applying power. The Reset switch is recessed to avoid accidental operation. To reset the unit, insert a small plastic tool, press lightly and hold for 3 seconds. The Link and Ready lights will go out and then come back on.

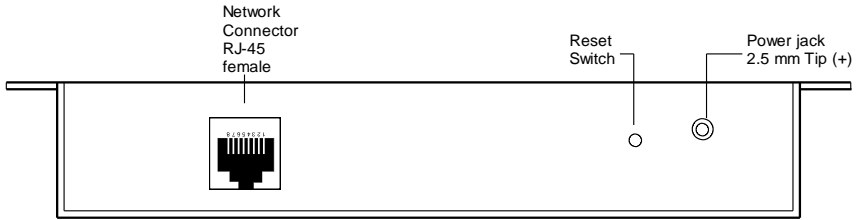

Figure 4. Top View of the ESP904

## Serial Ports

The ESP904 has four serial ports, each configurable through software as RS-232, RS-422 or RS-485 interfaces. When in RS-232 mode the interfaces are configured as DTEs (Data Terminal Equipment). The connectors are DB-9M.

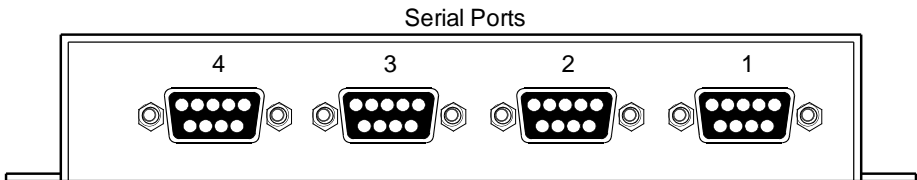

Figure 5. The ESP904 Serial Port Connectors

## Serial Server/Port Operational Modes

Using the **ESP Manager** the **ESP904 Serial Server** can be put into **Console Mode**, **Default Mode** or **Upgrade Mode**. The serial ports can be configured for RS-232, RS-422 or RS-485 operation.

### Default Mode

When **Default Mode** is selected and the Server Properties are **Updated (Saved)** all the configuration settings return to their default values. The default settings for the ESP904 serial ports are: **Console Mode** for Port 1; RS-232 mode for Ports 2, 3 and 4.

#### **Note:**

Refer to Chapter 5 for details on Server Configuration settings Refer to Chapter 12 for Serial Server default parameters.

## Console Mode

In **Console Mode** the ESP904 **Configuration Menu** can be accessed from a PC by connecting its RS-232 serial port to Port 1. Since the PC is a DTE device, and the ESP904 serial ports are configured as DTEs (with DB-9M connectors), a null modem crossover cable must be used.

In **Console Mode** the default serial port settings are: **9600 baud, 8 data bits, No parity, and 1 stop bit**. From Windows, HyperTerminal with VT100 terminal emulation can be used for **Console Mode** configuration.

**Note:**

*Refer to Chapter 9 for details on Console Mode*

---

## Upgrade Mode

In Upgrade Mode firmware can be uploaded from a PC via its serial port to the ESP904 Port 1, using RS-232. Upgrading also can be via the network connection, using the ESP Manager software and a virtual COM port mapped to the ESP904 Port 1.

**Note:**

*Refer to Chapter 8 for details on Upgrade Mode*

---

## RS-232 Mode

In **RS-232 Mode** the currently selected serial port is configured as an RS-232 interface supporting eight RS-232 signal lines plus Signal Ground and is configured as DTE like a computer. Signals are single ended and referenced to Ground. To use handshaking, Flow Control must be set to RTS/CTS during Configuration.

**Note:**

*Refer to Appendix A for RS-232 connection pin-outs.*

---

## RS-422 Mode

In **RS-422 Mode** the currently selected serial port is configured as an RS-422 interface supporting four RS-422 signal channels with full duplex operation for **Receive, Transmit, RTS** (Request To Send) and **CTS** (Clear To Send). The data lines are differential pairs (A & B) in which the B lines positive relative to the A lines in the idle (mark) state. Ground provides a common mode reference. To use handshaking Flow Control must be set to RTS/CTS during configuration.

**Note:**

Refer to Appendix B RS-422 connection pin-outs.

**RS-485 Mode**

In **RS-485 Mode Mode** the currently selected serial port is configured as an RS-485 interface supporting transmit (TX) and receive (RX) signal channels using 2-wire, half-duplex operation. The data lines are differential with the Data B line positive relative to Data A in the idle (mark) state. Ground provides a common mode reference.

**Note:**

Refer to Appendix C for RS-485 connection pin-outs.

**RS-485 Receiver Biasing** can be implemented from the ESP904 if the network does not supply it. Remove the two side-cover screws of the ESP904, slide the cover off and re-position the bias jumpers (shown open in the figure below) to enable biasing (shorting).

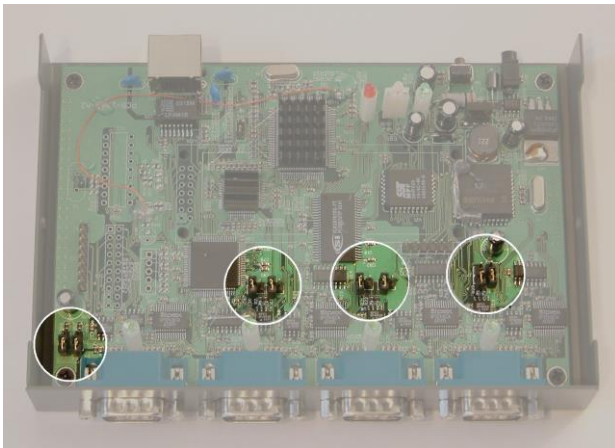

Figure 6. Internal Setting to Select RS-485 Bias

**Note:**

(For more information on RS-485 Receiver Biasing, see B&B Electronics RS-422/485 Application Note available at [www.bb-elec.com](http://www.bb-elec.com))

## ESP904 Serial Port Connector Pin-outs

Pin-outs for RS-232, RS-422 and RS-485 operation are shown below.

DB-9 Male  
outside

1 2 3 4 5

6 7 8 9

DB-9M Pin	RS-232 Signal Name	DTE		RS-422	RS-485
1	Carrier Detect	DCD	In	RXDA (-)	--
2	Receive Data	RXD	In	RXDB (+)	--
3	Transmit Data	TXD	Out	TXDB (+)	Data B (+)
4	Data Terminal Ready	DTR	Out	TXDA (-)	Data A (-)
5	Signal Ground	GND	---	GND	GND
6	Data Set Ready	DSR	In	CTSA (-)	--
7	Request To Send	RTS	Out	CTSB (+)	--
8	Clear To Send	CTS	In	RTSB (+)	--
9	Ring Indicator	RI	In	RTSA (-)	

Figure 7. Serial Connection Pin-outs for RS-232/RS-422/RS-485

**Note:**

For more information on RS-232, RS-422 and RS-485 pin-outs, cable connections and loopback connections refer to Appendices A, B and C

# Chapter 3: INSTALLING THE VLINX ESP SOFTWARE

The Windows-based **ESP Manager** and **Virtual COM Port** software makes configuration fast and easy. If using Windows, installing the ESP Manager software and setting up virtual COM ports to configure the ESP904 is recommended.

## Software Installation

The **VLINX ESP** software includes:

- **ESP Manager**
- **Install Virtual COM Ports**
- **Uninstall Virtual COM Ports**

### Automatic Installation

**Step 1a:** Inserting the VLINX CD in the CD-ROM should automatically launch the Install Shield Wizard.

### Manual Installation

**Step 1b:** To manually start the software installation, from the **Windows Destop**, click **Start** button. At the **Run** command line type **D:start.exe**. Then select **OK**. (**D:** is the drive letter for the CD ROM.)

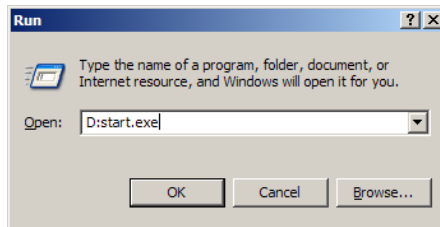

Figure 8. The Run Dialogue Box

The **Install Shield Wizard** window will be displayed.

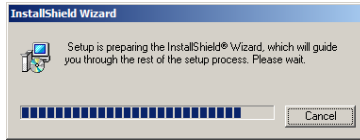

Figure 9. The Install Shield Wizard Window

**Step 2:** When the **VLINX ESP Setup** window appears, click **Next**.

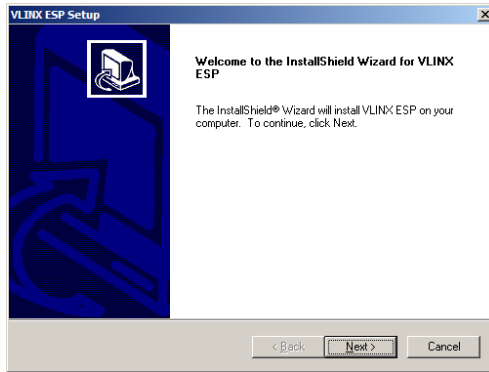

Figure 10. VLINX ESP Setup Window

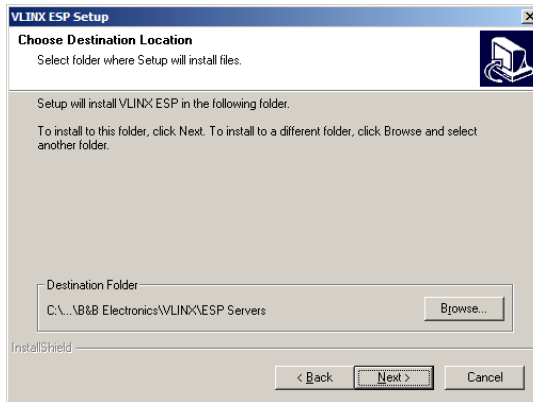

Figure 11. The Choose Destination Window

**Step 3:** When **Choose Destination Location** appears, click **Next**.

The installation progress will be shown until complete.



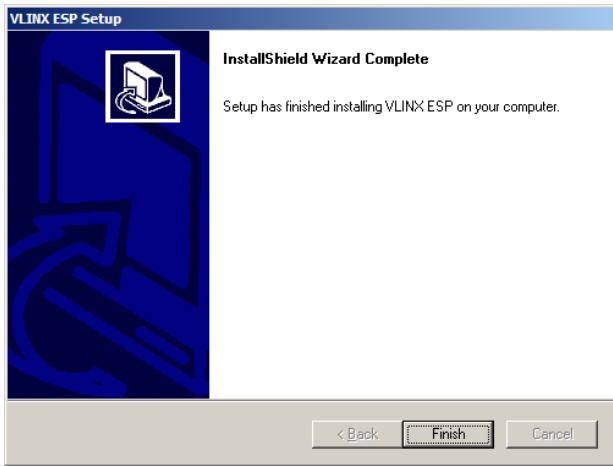

Figure 12. The Install Shield Wizard Complete Window

**Step 4:** Click **Finish** when the **Install Shield Wizard Complete** dialogue appears. When finished, dialogue box will close.

### Updating an Existing Installation

If an older version of the **ESP Manager** software is already installed, the **Modify, repair or remove the program** window will appear when the installation process is initiated:

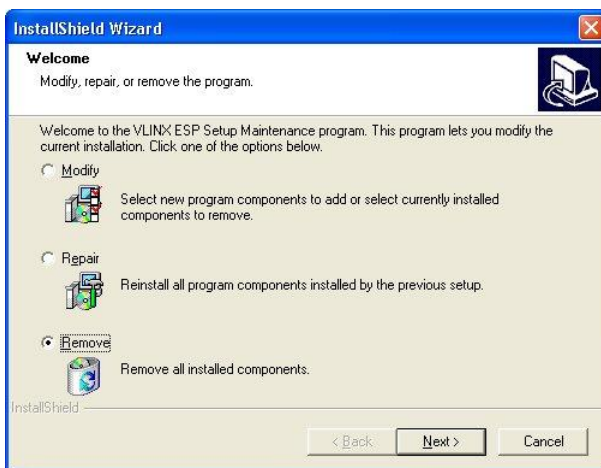

Figure 13. The InstallShield Wizard Modify, Repair or Remove Screen

The recommended procedure is to **Remove all installed components** first. Once the software has been removed, **Install** the new software.

## Opening the ESP Manager

**Step 5:** If the **ESP904** is not already connected to the network or to the Ethernet port on the computer, connect it. Apply power.

The **Power** indicator should light red, the **Link** light should indicate which type of Ethernet connection has been made and the **Ready** LED will flash indicating configuration can begin.

**Step 6:** Start the ESP Manager software. From the Windows Desktop, click:

**Start → Programs → B&B Electronics → VLINX → ESP Servers → VLINX ESP Manager.**

As soon as the **ESP Manager** opens it will initiate **Searching Server** and after a few seconds the **Serial Server List** will display all (ESP90x) **Serial Servers** on the network.

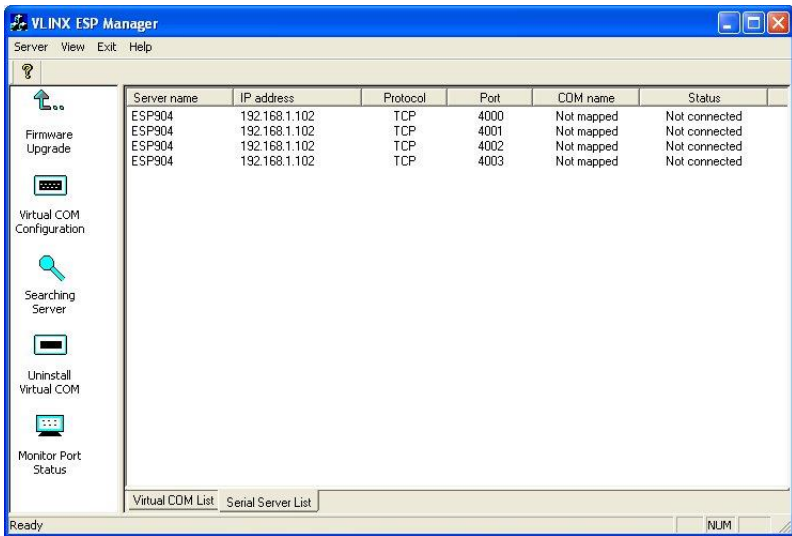

Figure 14. ESP Manager Displaying all ESP90x Serial Servers

# Chapter 4: USING ESP MANAGER

The **ESP Manager** software allows:

- Searching for servers connected to the network
- Displaying and changing the configuration of those servers
- Installing virtual COM ports on a computer
- Displaying and configuring virtual COM ports
- Uninstalling virtual COM ports on a computer
- Upgrading the ESP904 firmware
- Monitoring Port Status
- Saving and Loading Configuration Files

## Hardware Setup

**Step 1:** Connect the ESP904 to the LAN or to a computer Ethernet port.

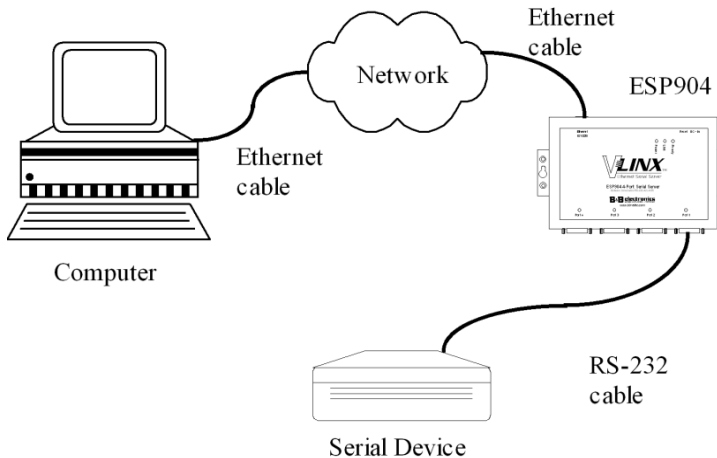

Figure 15. Ethernet Connection via a LAN

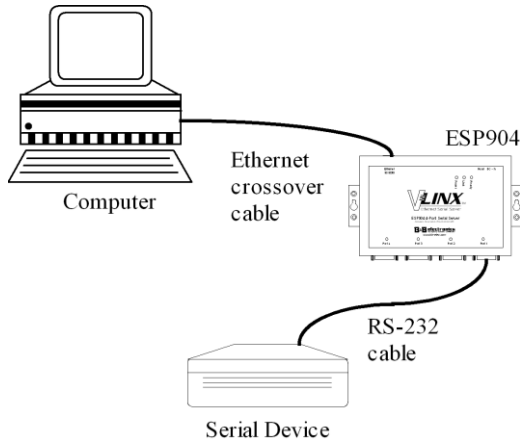

Figure 16. Direct Ethernet Connection using a Crossover Cable

**Note:**

Use an Ethernet Crossover Cable if connecting directly to a computer LAN card.

**Step 2:** Apply power. The Red Power indicator will light, the Link indicator lights when an Ethernet connection is made, and the Ready indicator will flash.

## Software Setup

**Step 3:** To run the **ESP Manager**, from the **Windows Desktop** click:

**Start → Programs → B&B Electronics → VLINX → ESP Servers → VLINX ESP Manager**

As soon as the **ESP Manager** opens it will initiate **Searching Server** and after a few seconds the **Serial Server List** will display all (ESP90x) **Serial Servers** on the network.

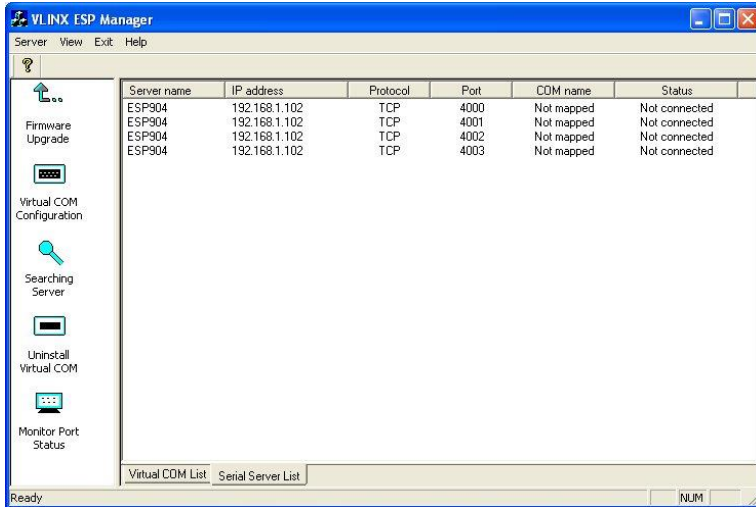

Figure 17. The VLINX ESP Manager Window

## Software Overview

The VLINX ESP Manager window provides the following information:

- **Menus** (Server, View, Exit, Help)
- **Server Icons** (Firmware Upgrade, Virtual COM Configuration, Searching Server, Uninstall Virtual COM, Monitor Port Status)
- **Serial Server / Virtual COM Lists**
- **Software Status** (Ready, Updating, Searching, etc)

## Menus

### Server

- **Firmware Upgrade** - Used when downloading new firmware to the **Serial Server**.

#### **Note:**

See Chapter 8 for more information on upgrading firmware.

- **Virtual COM Configuration** - Selects the **Virtual COM List**. Double clicking on any COM port in the **Virtual COM List** brings up a window that allows changing the virtual COM settings such as **Flow Control**, **Protocol**, **IP address**, and **Port Number**. Virtual COM settings must match **Serial Server** port settings.

- **Searching Server** - Searches for **Serial Servers** on the network and brings back configuration information that will be displayed in the **Server Properties** window.
- **Uninstall Virtual COM** - Allows virtual COM ports to be uninstalled from the **ESP Manager** window.
- **Monitor Port Status** - Brings up a screen that displays the following information associated with the selected serial port.



Figure 18. The Port Status Window

- **Serial TX:** Displays the number of bytes of data sent to the **serial device** since the IP connection was established.
  - **Serial RX:** Displays the number of bytes of data received from the connected **serial device** since the IP connection was established.
  - **DTR/RTS:** The **DTR/RTS Port Status** indicator displays the current logic state of the DTR and RTS hardware handshake (output) lines for the selected **Serial Server** port (1 = asserted, 0 = not asserted)
  - **DCD/DSR/CTS:** The **DCD/DSR/CTS Port Status** indicator displays the current logic state being received on the DCD, DSR and CTS hardware handshake (input) lines of the selected **Serial Server** port (1 = asserted, 0 = not asserted)
  - **Status:** Indicates whether the client software has made a connection with the **Serial Server**.
  - **IP Address:** Displays the IP address of the connected client when there is a client connection
- **Save Configuration File** - Allows the user to save the current configuration information to a file with a .vcom extension.
  - **Load Configuration File** - Allows the user to load a configuration file.

---

## View

Provides three viewing options for the ESP Manager screen:

- **Toolbar** – allows the toolbar (directly under the menu bar) to be viewable or hidden
- **Status Bar** – allows the Status Bar (at the bottom of the screen to be viewable or hidden
- **Split** – allows the position of the split between the Icons pane and the Virtual COM List / Serial Server List panes to be dragged horizontally using the mouse

## Exit

- Allows you to **Exit** the **ESP Manager** program

## Help

- Accesses the **About vcomui** dialogue box, which indicates the software version number

## Server Icons Pane

**Firmware Upgrade, Virtual COM Configuration, Searching Server, Uninstall Virtual COM** and **Monitor Port Status** can also be selected using icons located in the left window.

## Serial Server / Virtual COM Lists

To make management of lists of **Serial Server** easier, lists can be sorted by clicking on any tab heading. Scrolling bars facilitate scrolling through long lists.

### Serial Server List

- **Server Name** - Displays the name of the **Serial Server**. The name is listed once for each port.
- **IP Address** - Displays the IP Address for the **Serial Server**. All ports in a **Serial Server** have the same the same IP address.
- **Protocol** - Displays the currently selected TCP or UDP mode for the **Serial Server**.
- **Port** - Displays the port number for each **Serial Server** port.

- **COM Name** - Displays the name of the computer COM port mapped to each **Serial Server** port. If no computer port has been mapped it displays **Not mapped**.
- **Status** - The Status indicates the mapped virtual COM port condition.
  - **Not Connected** is shown when a program does not have the port Open.
  - **Connected** is shown when that mapped port is Open for use.

#### *Virtual COM List*

- **COM Name** - Displays the number of the COM port mapped to each **Serial Server** port.
- **IP Address** - Displays the IP Address for the **Serial Server**. All ports in a **Serial Server** have the same IP address.
- **Protocol** - Displays the currently selected TCP or UDP mode for the **Serial Server**.
- **Port** - Displays the port number for each **Serial Server** port.
- **Flow Control** - Indicates what type of flow control is configured for each port.
- **Status** - Indicates whether each port is currently **In Use** or **Not Used**.

### **Status Bar**

Displays the current status of the software in the bottom, left corner of the screen

- Ready
- Updating
- Searching reachable servers...

### **Search for Servers**

Upon opening the **ESP Manager** software it will automatically execute Searching Server and search for all reachable ESP90x serial servers.

**Step 4:** To manually initiate a search for servers, click **Searching Servers** (under the **Servers** menu or the icon on the left side of the screen). The **Search Setup** box will appear.

It provides two options for searching for servers on the network:

- Specify the IP Address of the Serial Server
- Search all reachable servers





Figure 19. The Search Setup Window

**Step 5:** Enter the **IP Address** assigned to the ESP904 or click **Search all reachable servers**, then **OK**. **IP Address** is used to find ESP904 units that are not on the same subnet. (Routers on the network will block the standard broadcast used to find servers if **Search all reachable servers** is selected.) The user must set an IP address that conforms to the LAN addressing scheme.

The Searching window is shown until all active ESP901/ESP902/ESP904 serial servers on the LAN are listed in the **Serial Server List** window.



Figure 20. The Search VLINX ESP Dialogue Box

## Configure Server Properties

**Step 6:** The **Server Properties** window displays the current configuration properties for the currently selected server.

To open the **Server Properties** window, highlight the serial server in the **Serial Server List** window, double-click to open.

The **Server Properties** window is used to configure and store the Server configuration settings. Details for setting Properties are shown in the next chapter.

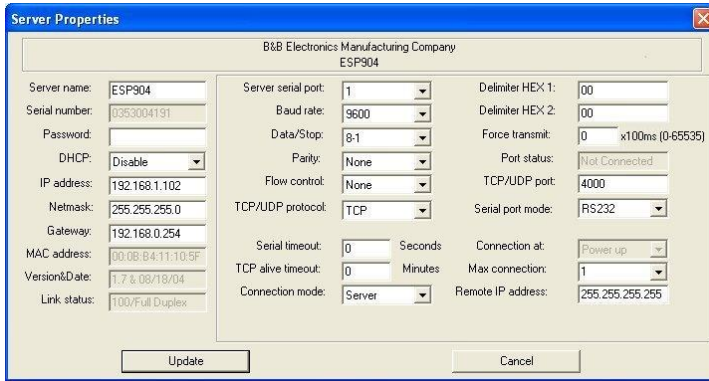

Figure 21. The Server Properties Window

### Note:

#### ESP Manager Navigation:

- Use the mouse to select the property and parameters or
- Tab to move to the next property
- Tab+Shift to move back to previous property
- Arrows to move between properties or change values or contents of the current property
- Enter to select update or cancel

**Step 7:** After configuring as needed, click **Update** to store the configuration in the server. The following window will appear:



Figure 22. The vcomui Window

**Step 8:** Click **Yes** to restart. The following dialogue box will appear:

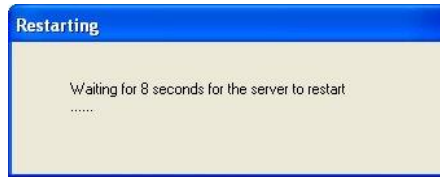

Figure 23. The Restarting Dialog Box

After eight seconds a dialogue box will ask whether you want to search for all reachable servers again.

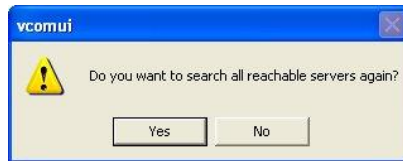

Figure 24. The Server Search Dialog Box

While the Serial Server is searching for all reachable servers the following dialogue box appears:

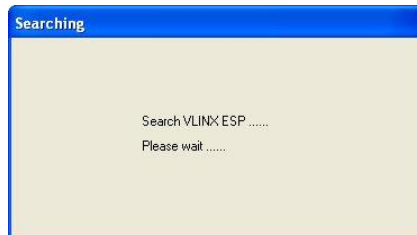

Figure 25. The Search VLINX ESP Dialog Box

After that port has been updated you may want to re-enter **Server Properties** to verify the changes have taken effect, or to view/change the configuration of other ports. Each port must be configured separately.



# Chapter 5: CONFIGURING THE ESP904 SERVER PROPERTIES

The VLINX Serial Server can be configured using any of four different user interfaces: the **ESP Manager** software, the **Web Server**, **Console Mode** or **Telnet**. The **Server Properties** described in this chapter can be changed from any of these user interfaces.

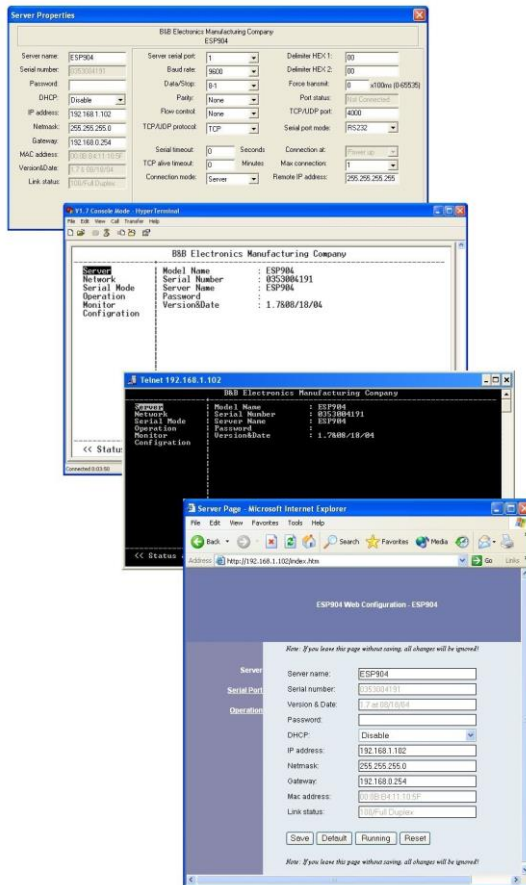

Figure 26. The Four Methods of Configuring Server Properties

## Description of the Server Properties

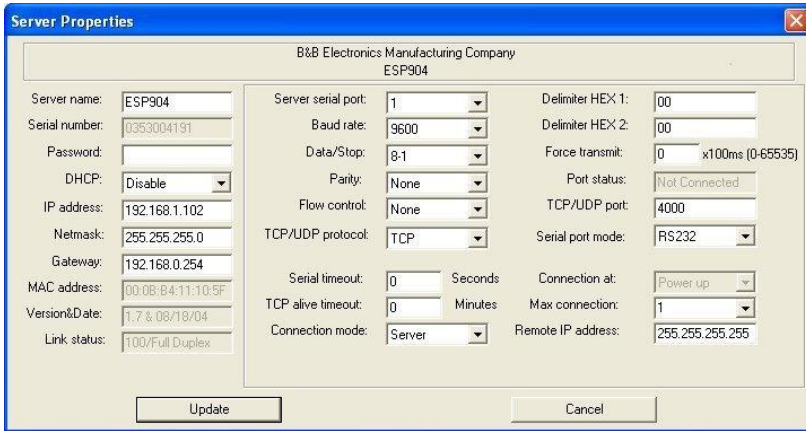

Figure 27. ESP Manager Server Properties Window

### Server Name

This field displays the name that has been assigned to the **Serial Server**. A new **Server Name** of up to 16 characters can be entered. If more than one **Serial Server** is connected on the LAN it is recommended that a new name be assigned to each. When the **ESP Manager** finds a **Serial Server** on the LAN it displays the server name and IP Address allowing the user to distinguish between **Serial Servers**.

### Serial Number

Each **Serial Server** has a unique serial number. This is fixed and cannot be changed.

### Password

Entering a password activates a security feature on the **Serial Server**. Once a password is entered it will be required to access the menu and make changes.

### DHCP

DHCP servers are a part of numerous LAN management systems. The DHCP field provides two choices: **Disable** and **Enable**. Disable is the normal, or default, setting. When enabled, the ESP904 will send a DHCP request to the DHCP server, which will assign a dynamic IP address, net mask, and

gateway to the ESP904. If a DHCP server is not available on the network the ESP904 will time out after 10 seconds and the default values will remain.

### **Note:**

A dynamic address assigned by the DHCP server may change if the ESP904 loses the Ethernet connection or power is removed. The host (client) communication software requests a connection to the specific IP address of the serial server. If the DHCP reassigns a different IP address the software will not be able to communicate with the hardware. Therefore, using a static IP address is recommended.

## **IP Address**

Software or hardware attempting to access the ESP904 server via the network must know the **IP Address** of the server. A static IP address is retained and remains the same each time the server is powered up or starts/restarts. The default IP address of the ESP904 server is printed on a label on the bottom cover of the ESP904. Entering an appropriate address in the IP Address field and updating the server will change the server's IP address. The network administrator can assign/establish the static address or group of addresses to be used.

The IP Address of the ESP904 server can be confirmed using the DOS Ping command.

### **Note:**

To use **Ping** to check for communications:

- Access a DOS window (in XP click **Start**, then **Run**)

- At run prompt enter: **CMD**

- In the DOS window enter: **Ping xxx.xxx.xxx.xxx** (IP address for the ESP904 to be confirmed)

- The command will return the Ping results indicating 4 replies

```

C:\WINDOWS\System32\cmd.exe
G:\>ping 169.254.13.206

Pinging 169.254.13.206 with 32 bytes of data:

Reply from 169.254.13.206: bytes=32 time=1ms TTL=64
Reply from 169.254.13.206: bytes=32 time=1ms TTL=64
Reply from 169.254.13.206: bytes=32 time=1ms TTL=64
Reply from 169.254.13.206: bytes=32 time=1ms TTL=64

Ping statistics for 169.254.13.206:
    Packets: Sent = 4, Received = 4, Lost = 0 (0% loss),
    Approximate round trip times in milli-seconds:
        Minimum = 1ms, Maximum = 1ms, Average = 1ms

C:\>

```

Figure 28. Pinging using the DOS command window

## Netmask

The default LAN netmask is configured for a Class C address. The user may change this. Default is 255.255.255.0

## Gateway

The Gateway IP address allows users to access the serial server from outside the LAN.

## MAC Address

The MAC address is fixed and cannot be changed. It is assigned in the factory. Every Ethernet device manufactured has its own unique MAC address.

## Version & Date

The currently loaded version of the firmware, and when it was released, is shown here.

## Link Status

Link status automatically displays the type of Ethernet connection. It will either display 10BaseT or 100BaseTX in full duplex or half duplex. This will depend on the LAN, switches, hubs used in the LAN topology.

## Server Serial Port

This field indicates the number of the port for which **Serial Server** properties are currently being displayed. Changing the number in this field will cause all the other fields to display the properties for the specified port. Note, however, that before changing ports, any changes to properties must be **Updated** (Saved) or the **Serial Server** will not retain them.

### **Note:**

*Click Update to store settings for each port before changing to the other port.*

## Baud Rate

The serial port baud rate on the ESP904 must match the serial baud rate of the connected device unless using Virtual COM mode. In Virtual COM mode the software program will establish serial settings.



## Data/Parity/Stop

Set this to match the data format used by the device connected when the Virtual COM mode is not being used.

## Flow Control

The Flow Control setting must match the requirements of the device connected.

### Note:

Select None when setting ESP Port 1 as RS-485 or 4-wire RS-422.

## TCP/UDP Protocol

Select TCP (Transmission Control Protocol) or UDP (User Datagram Protocol) protocol. If the application does not require a UDP connection, select TCP. TCP guarantees reliable communication with error checking whereas UDP provides faster transmission.

### UDP Mode

When UDP mode is chosen the **Serial timeout**, **TCP alive timeout**, **Connection mode**, **Connection at**, **Max connection** and **Remote IP address** fields disappear and are replaced with four **Destination IP address range**, **Port number** **Source IP address range** fields. In this mode the server can be configured to broadcast data to and receive data from multiple IP addresses. Four IP address range fields are provided.

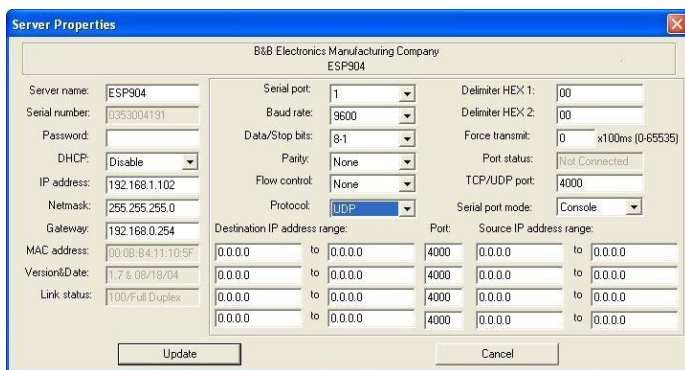

Figure 29. The Server UDP Configuration Screen

## Serial Timeout

Default for the **Timeout** property is 0, or no timeout. Setting **Timeout** to any value between 1 and 65535 seconds activates it. If **Timeout** is set to 5 seconds and the **Serial Server** is configured as a **Server**, the **Client** makes a connection and communications starts. If communications are ideal for 5 seconds the **Serial Server** will reset and make itself available for another client connection.

## TCP Alive Timeout

The **Serial Server** monitors TCP activity. If TCP activity stops for the length of time specified in this field the connection will be closed. This field can be set to any value between 0 and 255 minutes. If zero, or no value, is entered into this field the server will not disconnect.

## Connection Mode

The Connection Mode field has three options: **Server**, **Client** and **Client (no heartbeat)**. When **Client** or **Client (no heartbeat)** is selected the **Connection at** field automatically becomes active (allowing the user to select **Power up** or **Data Arrival**).

- When using the **Virtual COM Port** feature, select **Server**.
- When using a **TCP** or **UDP Socket** program, select **Server**.
- When using **Paired Mode** communication between two serial servers set up one as a **Client** and the other as a **Server**.
- When connecting to a server that does not support **Heartbeat**, select **Client (no Heartbeat)**.

## Delimiter HEX 1 and Delimiter HEX 2

These fields allow the user to enter two ASCII characters (in hex format) that delimit the beginning and end of a message. When a message with both these delimiters is received at the serial port, the data contained in the serial buffer is placed in an Ethernet packet and sent out the Ethernet port. If only Delimiter 1 is set (Delimiter 2 is zero or blank), upon receiving Delimiter 1 the ESP901/902 will put all the data in the serial buffer in an Ethernet packet and send it out the Ethernet port. If serial data greater than 1 kilobyte is received it will automatically be placed in an Ethernet packet and sent out the Ethernet port.

## Force Transmit

This field allows the user to set a maximum time limit between transmissions of data. The value set in this field multiplied by 100 ms determines the Force Transmit time. When the elapsed time reaches the time configured in this field, the TCP/IP protocol will pack the data currently in the serial buffer into a packet and send it out the Ethernet port.

## Port Status

This field indicates whether a serial port is connected via the **Serial Server** to a virtual COM port of a device on the network.

## TCP/UDP Port

This sets the port number for connection. The default port number is **4000**, **4001**, **4002**, and **4003** for serial ports 1, 2, 3, and 4 respectively.

In all modes of operation, **Direct IP** or **Virtual COM**, the port number set in the ESP904 menu must match the **Virtual COM** or socket software port settings.

### **Note:**

*Example: The Virtual COM default setting is TCP/UDP Port 4000. If the port # property is changed to 4001, the virtual COM port will have to be changed to 4001. The hardware settings can be changed from the ESP Manager or Console Configuration Menu. The Virtual COM port setting also can be changed within the Device Manager of the computer on which it is installed.*

## Serial Port Mode

**Serial Port Mode** allows configuration of the serial server for the following modes of operation:

- **Console** – When this mode is selected and the server is updated, a PC running a communications program such as HyperTerminal can communicate with the **Serial Server** via the **Console Mode** serial port (the serial Port on ESP901 or Port 1 on ESP902), displaying the **Server Properties** screen and allowing configuration of the server and its ports.
- **Upgrade** – When this mode is selected and the server is updated, firmware can be uploaded into the **Serial Server** via the **Console Mode** serial port or a virtual COM port mapped to the number of the **Console Mode** serial port.
- **Default** – When this mode is selected and the server is updated, it will revert the server to its default configuration.

- **RS-232** – When this mode is selected and the server updated, the selected serial port will become an RS-232 serial port on the server.
- **RS-422** – When this mode is selected and the server updated, the selected serial port will become an RS-422 serial port on the server.
- **RS-485** – When this mode is selected and the server updated, the selected serial port will become an RS-485 serial port on the server.

## Connection At

When the **Connection Mode** field is set to **Client** or **Client (no heartbeat)**, this field becomes active, allowing the ESP901/902 (acting as a client) to connect to the server either on **Power up** or on **Data Arrival** (first character arriving).

## Max Connection

This field allows the user to configure the **Serial Server** to have up to eight TCP connections.

## Remote IP Address

This is a security feature activated by entering the IP address of the desired client. The ESP904 will only communicate with the listed IP address and all other requests for connection will be filtered out. The ESP904 must be set up as a **TCP** or **UDP Server** to use this feature. The default setting is **255.255.255.255**.

If **Paired Mode** is not being used, do not change this setting until the application has been tested and is communicating properly. Then activate the address filtering feature.

### **Note:**

Refer to Chapter 1 Paired Mode

## Update/Save

Server properties must be updated separately for each serial port. Updating varies slightly depending on which of the four configuration user interfaces are used.

### *Updating the Server Properties in ESP Manager*

From the **Server Properties** screen, click the **Update** button to store the configuration settings for the currently selected port. The vcomui dialogue box will appear indicating you must restart the device before the new settings will take effect.



Figure 30. The Restart Dialog Box

The following dialogue box will appear:

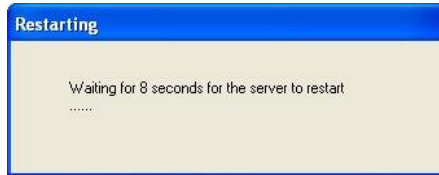

Figure 31. The Restarting Dialog Box

After eight seconds a dialogue box will ask whether you want to search for all reachable servers again.

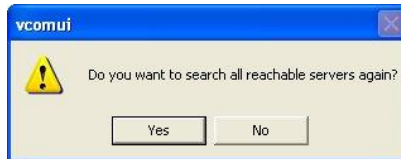

Figure 32. The Server Search Dialog Box

While the Serial Server is searching for all reachable servers the following dialogue box appears:



Figure 33. The Search VLINX ESP Dialog Box

After that port has been updated you may want to re-enter **Server Properties** to verify the changes have taken effect, or to view/change the configuration of other ports. Each port must be configured separately.

*Saving Configuration Data in Console Mode or Telnet*

Saving (updating) server properties is done from the **Configuration** screen. Access the **Configuration** screen by tabbing through the list of screens on the left side of the window and highlighting **Configuration**.

There are four options shown on the right side of the **Configuration** screen: **Save**, **Default**, **Running** and **Reset**. Use **Tab**, **Backspace**, or **arrow** keys to move the cursor to the option position, and then press **Enter**.

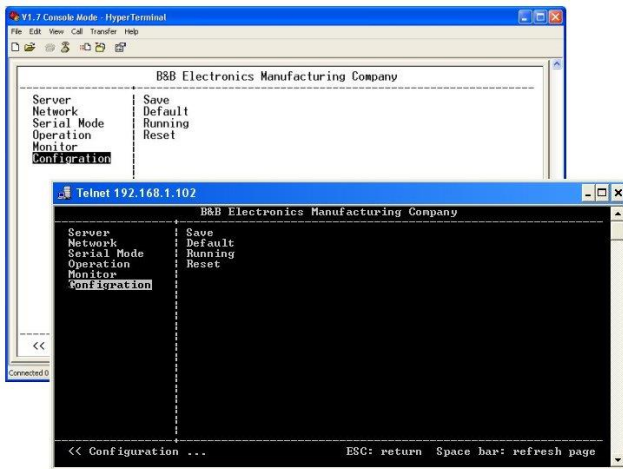

Figure 34. Console Mode and Telnet Configuration Screens

- **Save** stores the configuration data to the **Serial Server** flash memory and resets it.
- **Default** restores the configuration data to factory default settings.
- **Running** restores the configuration data to the last values stored in the flash memory.
- **Reset** re-boots the **Serial Server**, making it available for a client connection.

## Web Server Interface

- The **Web Server** interface provides the same updating options as **Console Mode** and **Telnet**. These are located at the bottom of all three **Web Server** pages. If a field is changed, you must click **Save** before leaving that page or the changes will be ignored.

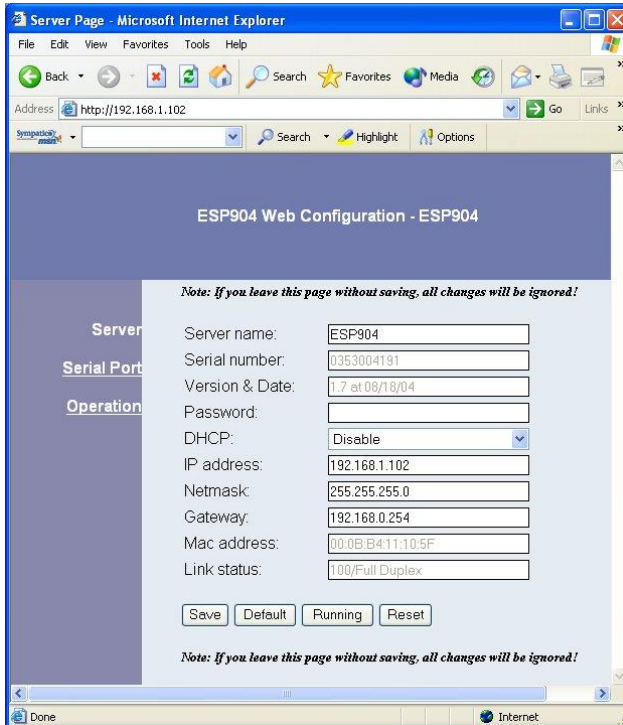

Figure 35. The Web Server Page

### **Note:**

If you leave any Web Server page without saving, any changes you have made will be ignored.





# Chapter 6: INSTALLING VIRTUAL COM PORTS

The **Virtual COM Port** feature allows Windows platform software, using standard API calls, to be used in an Ethernet application.

The **Install Virtual COM port** software adds an **ESP904 (COM#) port** to the computer. This shows up in the **Device Manager**. The COM number can be selected from a list of available numbers. For example, in a computer already having a COM1 and COM2, COM3 to COM 254 is available for the ESP904. It is recommended that COM Port 5 or higher be selected. The virtual COM port looks like a standard COM port to most Windows based applications which allows the software to open a connection with the serial port located anywhere on the LAN/WAN. When using the virtual COM port the ESP904 is configured as a TCP or UDP Server.

## Virtual COM Port Installation

**Step 1:** In Windows, select **Install Virtual COM** from the **Programs** list.

**Start → Programs → B&B Electronics → VLINX → ESP Servers  
→ Install Virtual COM**

The **Search Setup** window will appear.

**Step 2:** Select the **Search all reachable servers** check box, then click **OK**.



Figure 36. The Search Setup Window

The program searches the LAN for all available ESP901/ESP902/ESP904 Serial Servers. When complete, the **Found Server** window appears and displays a list of the servers that were found.

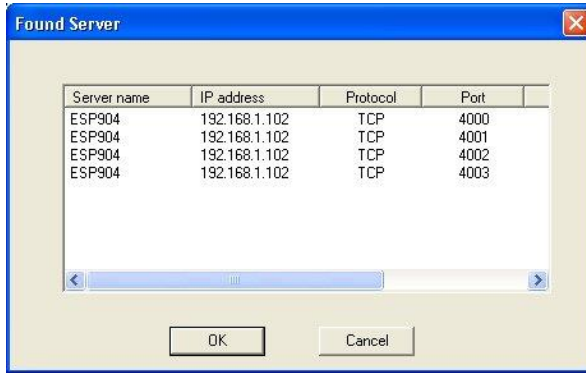

Figure 37. The Found Server Window

**Step 3:** Select the **Serial Server** at the IP Address to be mapped to a virtual COM port, then click **OK**.

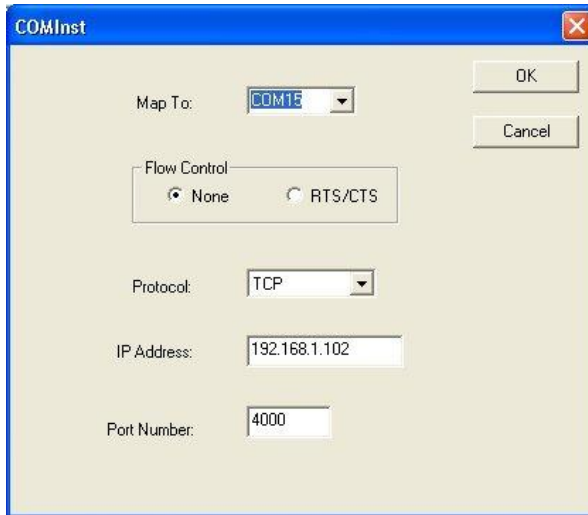

Figure 38. The COMInst Window

**Windows XP/Vista** provides a notice concerning Windows Logo testing for XP/Vista.



Figure 39. The Windows Logo Testing Window

This XP/Vista feature simply indicates that these drivers have not yet undergone the Microsoft testing procedures required to use the Windows XP/Vista Logo on the packaging. Driver compatibility is not affected.

**Step 4:** Click **Continue Anyway** to proceed with the installation.

The Protocol TCP/UDP, IP Address, and Port Number will mirror the settings of the selected serial server.

**Step 5:** After setting all four ESP Serial Ports as virtual COM ports, click **Cancel** on the **Found Server** form.

**Note:**

*PCs may have hardware COM ports and devices such as Modems, IR ports or USB based COM ports that are not currently connected Try selecting a COM number above COM4 if problems occur.*

The default **Flow Control** setting is **None**. RTS/CTS can be selected if used by the application program and serial hardware. The ESP Server must be set to match.

## Matching the ESP904 and Virtual COM Port Settings

The settings of the virtual COM ports in the Device Manager and the ESP904 Configuration menu must match. If the settings do not match, the virtual COM ports will not work. If these settings are changed in the Device Manager, it will only affect the operation of the virtual COM port. It will not change the settings stored in the ESP904. Use the ESP Manager to change the ESP904 Server settings.

**Step 1:** Use Device Manager to **View New Ports**

Confirm the virtual COM ports in the Device Manager.

**Step 2:** Double-click **Ports** to view the list of COM port numbers.

The installed Virtual COM port will be displayed as **VLINX ESP (COM #)**.

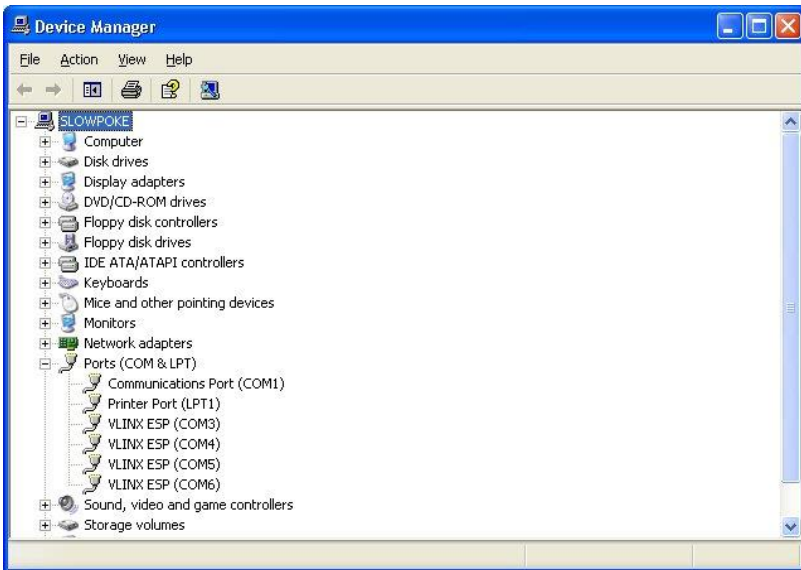

Figure 40. The Device Manager Window

**Step 3:** In the Device Manager select a **VLINX ESP COM#**. Double-click it to bring up the **Properties** window.

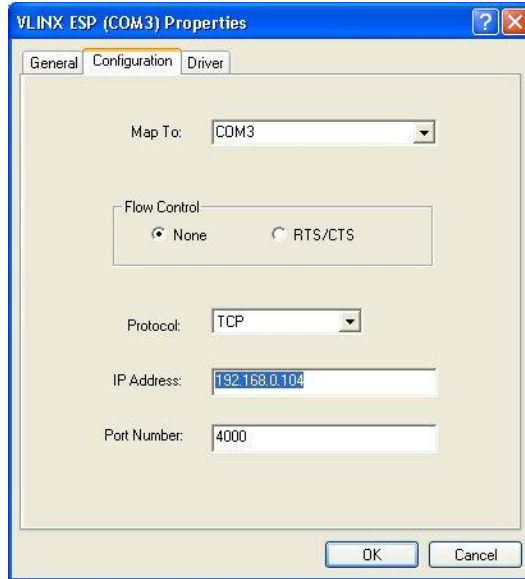

Figure 41. The VLINX ESP (COM3) Properties Window

**Step 4:** Click the **Configuration** or **Port Settings** tab. This screen allows the settings to be changed if necessary. Click **Cancel** to keep the existing settings.

**Step 5:** Click **OK** to change the settings. Use **Refresh** in the Device Manager if Windows does not auto refresh.



# Chapter 7: REMOVING VIRTUAL COM PORTS

The **ESP Manager** software **Uninstall Virtual COM Port** feature will remove a mapped COM port in the Device Manager of Windows 2000, 2003, XP and Vista operating systems. It may also be removed in the Device Manager of Windows 98, ME, NT, 2000, 2003, XP and Vista. Windows 98 users also will find a **Remove Virtual COM** feature in the Programs file.

## Removing the Virtual COM port with ESP Manager

**Step1:** From the Windows Desktop, click:

**Start → Programs → B&B Electronics → VLINX → ESP Servers → VLINX ESP Manager**

**Step 2:** In the **ESP Manager** window click the **Virtual COM List** tab. Highlight the mapped COM port number to be removed.

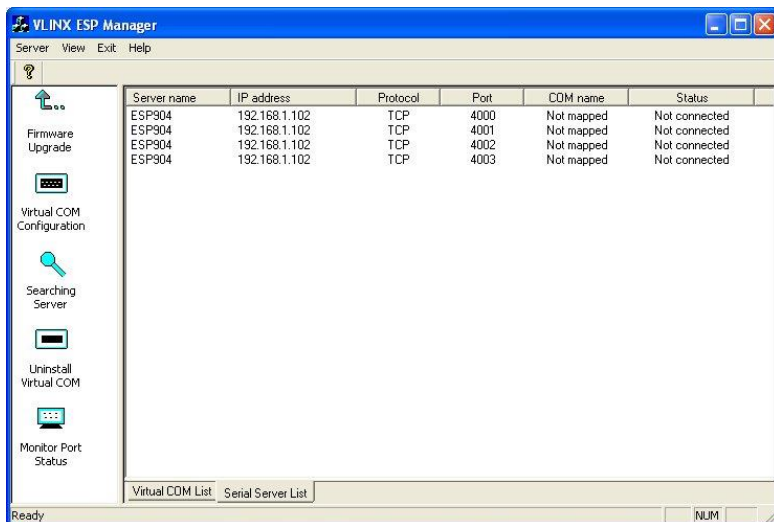

**Figure 42.** The ESP Manager Window

**Step 3:** Click **Uninstall Virtual COM** button. The Manager will ask for conformation. Click **OK** to complete the uninstall procedure.

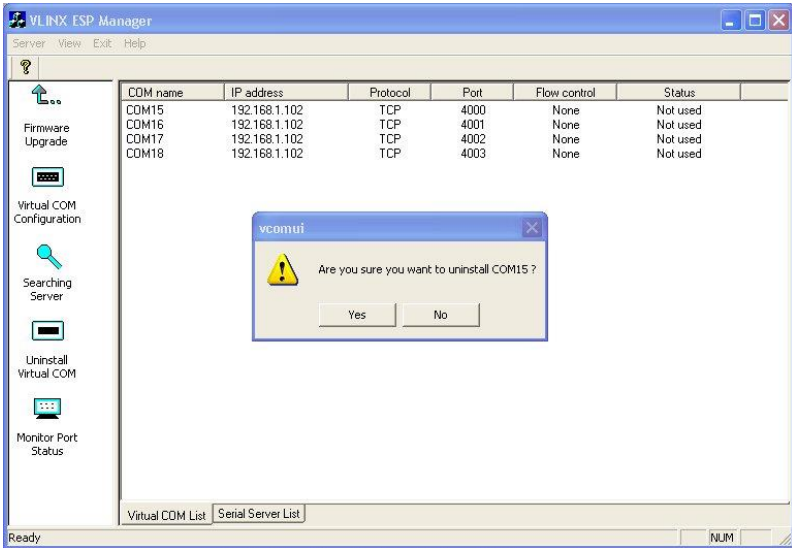

Figure 43. The vcomui Dialogue Box

## Removing the Virtual COM Port using Device Manager

**Note:**

The screen shots were taken from a Windows XP operating system

**Step 1:** From the Windows **Desktop** click:

**Start → Settings → Control Panel.**

**Step 2:** Click the **System** icon when the manager window opens.



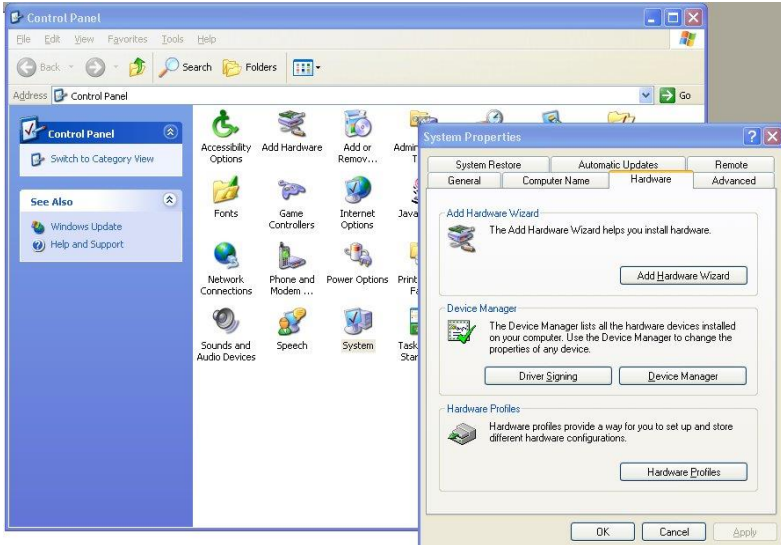

Figure 44. The Control Panel Window

**Step 3:** Click **Device Manager** in the **Systems Properties** window. In the Device Manager dialogue click the **+** next to **Ports (COM LPT)** to expand.

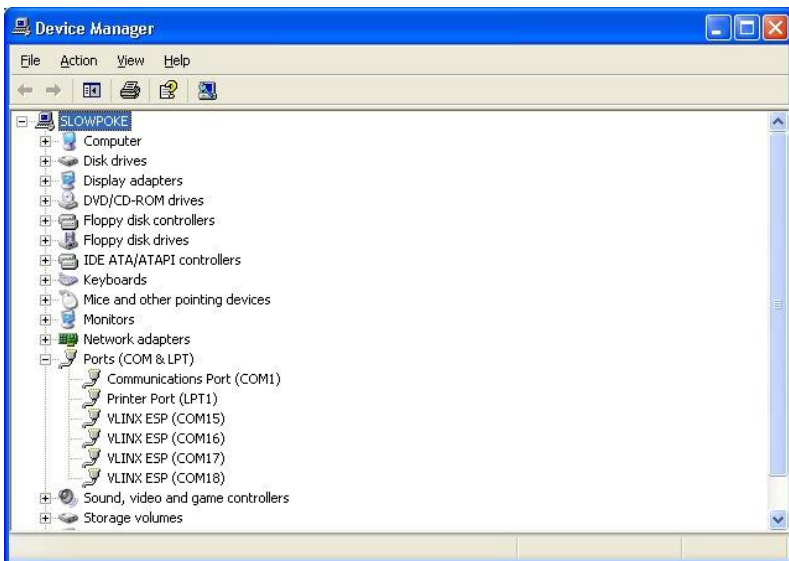

Figure 45. The Device Manager Window

**Step 4:** Highlight **ESP904 (COM #)** to be removed and click the **Action** tab at the top of window, then click **Uninstall**. A confirm **Device Removal** window will appear.

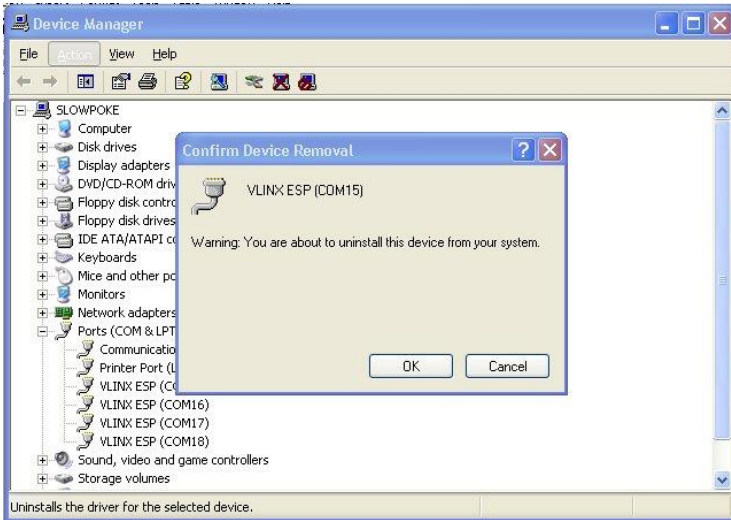

Figure 46. Confirm Device Removal

**Step 5:** click **OK** to proceed.

The ESP904 COM # will be removed and the Device Manager window will refresh and display the remaining COM ports

---

# Chapter 8: UPGRADING THE ESP904 FIRMWARE

---

New ESP904 firmware updates may become available through the B&B Electronics website for installation into the ESP904. The firmware can be uploaded to the ESP904 using either a virtual COM port connection or hardware COM port connection to ESP904 serial port 1.

## Downloading the Firmware

Make a folder to receive the firmware file. Download the compressed software file from the B&B Electronics website. Unzip or expand the file into the (.hex) format so it will be ready to upload to the ESP904.

## Upgrading Via ESP Manager

The ESP Manager software can upload new firmware to the server using a direct PC connection via Port 1 of the ESP904, or using a virtual COM port mapped to Port 1.

### **Note:**

*If connecting directly to a computer serial port, connect a null modem cable between the Computer RS-232 port and the ESP904 Port1 serial port.*

## Preparing the Software

**Step 1:** From the ESP Manager, in the **Serial Server List** window, double click the server to be upgraded. The **Server Properties** window will appear.

**Step 2:** If using a direct connection to serial port 1 to upload the firmware to the ESP904, set the baud rate to **115200** for the fastest possible upload.

**Step 3:** Set the **Serial Port Mode** field to upgrade and click the **Update** button.

**Step 4:** Click **Yes** on the **vcomui** dialogue to restart the ESP904.

## Upgrading the Firmware

**Step 5:** Double-click the **Firmware Upgrade** icon (or click the **Server** menu and **Firmware Upgrade**)

**Step 6:** In the **Upgrade** window, click **Browse**. The Open dialogue box will appear. Locate the folder that contains the firmware .hex file. Select the file and click **Open**. The Open dialogue box will disappear.

**Step 7:** In the **Upgrade** window select the serial port to be used in transferring the firmware.

- a. If connected directly from the computer to Port 1 of the ESP904 the port will typically be COM1 or COM2
- b. If using a virtual COM port to upgrade via the network, identify the virtual COM number and address mapped to Port 1 on the ESP904.

**Step 8:** Click **Upgrade**

**Step 9:** In the **Port Settings** window set the **Bits per second**, **Data bits**, **Parity** and **Stop** bits to the same values as set up in the **Server Properties** window. Click **OK**.

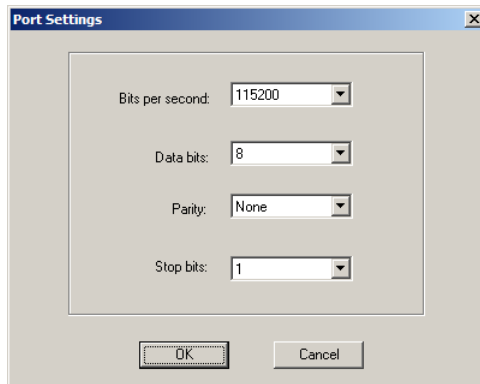

Figure 47. The Port Settings Window

**Step 10:** Upgrade progress will be shown until the **Upgrade finished!** message is shown. Click **OK**.

---

## Chapter 9: USING CONSOLE MODE

---

Before the ESP904 is installed on a LAN the **Console Mode** can be used to change the settings from the defaults. The ESP904 is shipped in the **Console Mode**. Connect a crossover (null modem) cable between the ESP904 Port1 and the COM port on the Computer.

**Note:**

See Chapter 5 for details of each Server Property Settings.

---

### Console Mode Setup

**Step 1:** Apply power to the ESP904. The power and ready LED will light.

**Step 2:** Using a VT100 Terminal emulation program (typically **HyperTerminal** in Windows) open the computer COM port connected to the ESP904 Port 1 (via an RS-232 crossover cable).

**Step 3:** In the HyperTerminal **Port Settings** window set:

- Baud rate: 9600
- Data bits: 8
- Parity: None
- Stop bits: 1
- Flow control: None

Click **OK**

**Step 4:** To view the **Configuration Menu**, press the **space bar**. The menu will appear within a few seconds.

## Navigating the Configuration Menus

There are six **Console Mode** screens: **Server**, **Network**, **Serial Mode**, **Operation**, **Monitor** and **Configuration**. **Tab**, **Back Space** and **arrow keys** can be used to highlight the desired function on the screen list. Pressing **Enter** moves the cursor to the first field with the current screen. The configuration fields can be changed by pressing **Enter** and selecting from the list that appears. The **Escape** key moves the cursor back to the screen list. Pressing the **Space Bar** refreshes the page.

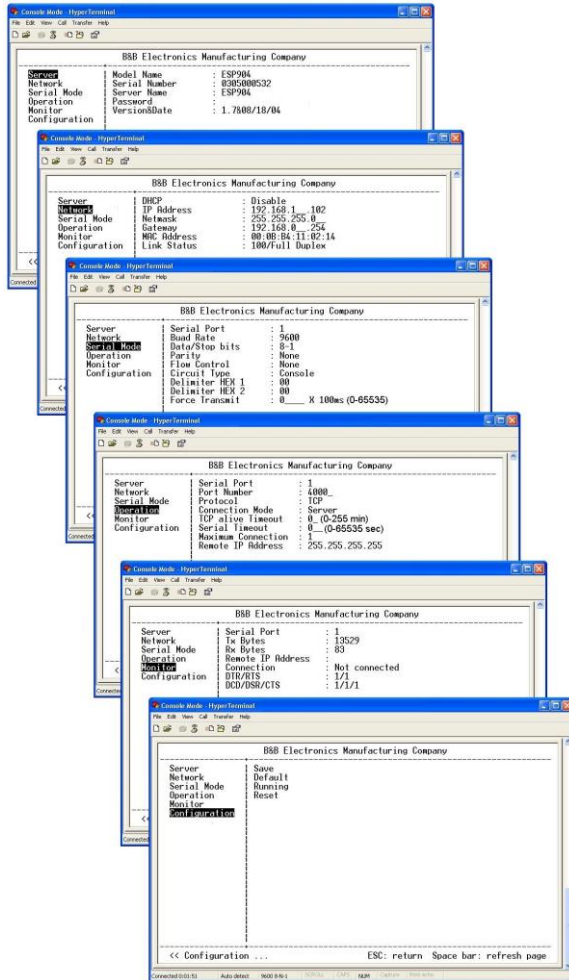

Figure 48. Console Mode Configuration Screens

**Step 5:** Once all the changes have been made move to the **Save** field and select **Enter**.



Figure 49. Saving and Restarting the Configuration

The restart message will appear.

**Step 6:** Select **Yes** to save changes. This is necessary to write the settings to the server.

### Using a Password

If a password is used it must be entered before the Configuration screen can be seen. If the server is accessed with a password but no changes are made, **Reset** to end before disconnecting.





# Chapter 10: USING THE WEB SERVER

The Web Server can be used to configure the ESP904 from any web browser software (such as Internet Explorer). Server properties can be set up using two browser pages.

## **Note:**

See Chapter 5 for details on Server Properties.

## Setting Server Properties

In Internet Explorer type the IP Address of the ESP904 into the address field near the top of the window and press the **Enter key**. The following window will appear:

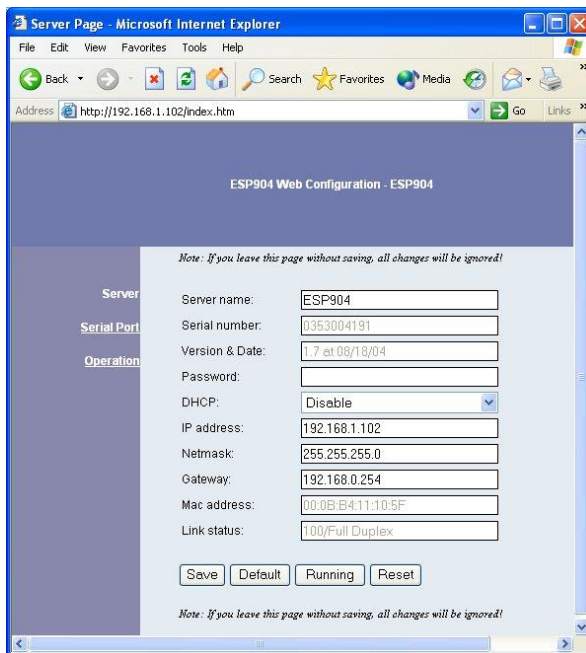

Figure 50. The Web Server Page

Navigate and change properties as required using the mouse and keyboard.

To change serial port properties, click **Uart Port** on the left side of the browser window. The following page will appear:

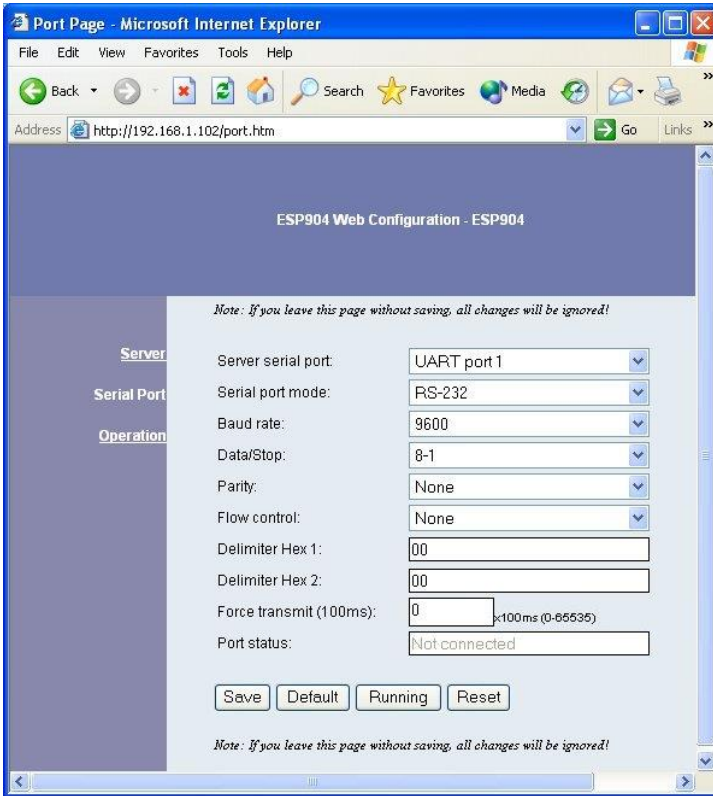

Figure 51. The Web Server Serial Port Properties Page

To change other operational properties, click **Operation** on the left side of the browser window. The following page will appear:

Figure 52. The Web Server Operation Page

Click **Save** to store changes to the ESP904. Settings for each Port must be saved separately.

**Note:**

*If new property settings are not **saved** before leaving this page they will not take effect.*

Return to the main Server page by clicking on **Server** on the left side of the browser window.



# CHAPTER 11: Using Telnet

**Telnet** can be used to configure the **Serial Server** from any PC on the LAN. The **Telnet** window displays the same configuration information shown in **Console Mode** and allows server properties to be configured.

**Note:**

See Chapter 5 for details on Server Properties.

## Configuration Using Telnet

- Step 1:** Ensure the PC and **Serial Server** are connected to the LAN.
- Step 2:** Apply power to the **Serial Server**. The power and ready LED will light.
- Step 3:** From the **Desktop**, click **Start**, then **Run**. The Run dialogue box will open.
- Step 4:** Type in **Telnet** and the IP address of the **Serial Server** to be configured, then click **OK**.

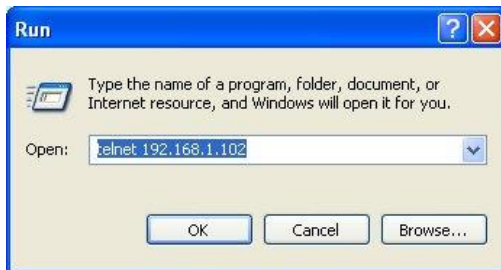

Figure 53. The Run dialogue box

**Note:**

The **Serial Server** must be in **RS-232**, **RS-422** or **RS-485** mode before you can **Telnet** to it and access the configuration screens. If it was last configured in **Console mode** you may not be able to access it using **Telnet**. In this case use **ESP Manager**, **Console Mode** or **Web Server** for configuration.

**Step 5.** The **Telnet** window will open (unless the server is still in Console mode) and the **Server** screen will appear.

## Navigating the Configuration Menu

There are six **Telnet** screens: **Server**, **Network**, **Serial Mode**, **Operation**, **Monitor** and **Configuration**. **Tab**, **Back Space** and **arrow** keys can be used to highlight the desired function on the screen list. Pressing **Enter** moves the cursor to the first field with the current screen. The configuration fields can be changed by pressing **Enter** and selecting from the list that appears. The **Escape** key moves the cursor back to the screen list. Pressing the **Space Bar** refreshes the page.

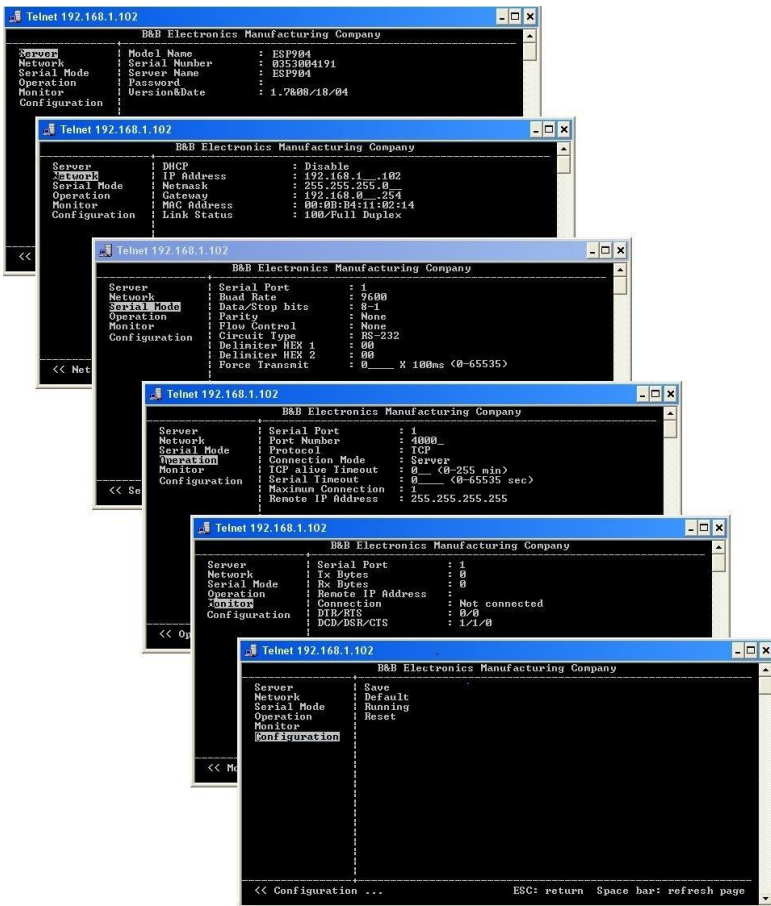

Figure 54. Telnet Configuration Screens

**Step 5:** Once all the changes have been made move to the **Save** field and select **Enter**. The restart message will appear.



Figure 55. Saving and Restarting the Configuration

**Step 6:** Select **Yes** to save changes. This is necessary to write the settings to the server. The Telnet window will disappear.

**Step 7:** To view the changes re-enter **Telnet** and re-establish communications. The configuration menu will appear and display the current settings.





# Chapter 12: ESP904 TECHNICAL DATA

<b>Hardware and Included Accessories</b>	<b>ESP904 Serial Server module</b> <b>Power Supply:</b> 12 VDC/1A (tip positive/sleeve negative) <b>Power Plug:</b> (Area Dependent: North America 120VAC/60Hz, Europe/United Kingdom 220/240VAC/50Hz) <b>Manual:</b> Paper copy of this manual, PDF available <b>CD-ROM disc:</b> VLINX ESP Manager and Virtual COM Driver software for Windows 98/ME/2000/2003/XP/NT 4.0/Vista
<b>Dimensions</b>	<b>ESP904:</b> 4.5 x 7.3 x 1.1 in (11.4 x 18.5 x 2.9 cm)
<b>Power &amp; Environment</b>	<b>Power Requirements:</b> 12 VDC @ 500 mA <b>Operating Temperature:</b> -10 to +80 °C <b>Storage Temperature:</b> -20 to 85 °C <b>Humidity:</b> 0 – 90% non-condensing <b>Approvals:</b> CE, FCC
<b>Indicators</b>	<b>Power:</b> Red LED <b>Link:</b> Yellow or green LED (10BaseT or 100 BaseTX) <b>Ready:</b> Flashing green LED <b>Serial Ports (4):</b> Flashing green LED when data present (see Ch. 2)
<b>Connectors</b>	<b>Ethernet:</b> Single RJ-45 female <b>Serial:</b> Four - 9 pin D-type male (DB-9M) DTE (all ports are software selectable as RS-232, 422, or 485) <b>DC Power:</b> Ultra-miniature phone jack (2.5mm), Tip (+), Sleeve (-)
<b>Serial Interfaces</b>	<b>RS-232(DTE):</b> TXD, RXD, RTS, CTS, DTR, DSR, DCD, GND <b>RS-422:</b> TXDB(+), TXDA(-), RXDB(+), RXDA(-), RTS(+), RTS(-), CTS(+), CTS(-) and GND <b>RS-485:</b> Data B (+), Data A (-) and GND <b>Baud Rate:</b> 110 bps to 230.4 k bps <b>Parity:</b> None, even, odd, mark, space

	<b>Data Bits:</b> 7 or 8 <b>Stop Bits:</b> 1, 1.5 or 2
<b>Memory</b>	<b>Serial Memory:</b> 8K bytes per port
<b>Network Communications</b>	<b>LAN:</b> 10/100 Mbps Auto-detecting 10 BaseT or 100 BaseTX
<b>Protocols</b>	TCP, IP, ARP, DHCP, Telnet, HTTP, UDP, ICMP
<b>Configuration Options</b>	<b>Console Mode:</b> Using RS-232 with VT100 emulation <b>Telnet Mode:</b> Using HyperTerminal with VT100 emulation <b>ESP Manager:</b> Using Windows 98/ME/2000/2003/XP/Vista/NT software <b>Web Server:</b> Using a standard web browser such as Internet Explorer
<b>Default Server Settings</b>	<b>Server Name</b> ESP904 <b>Serial Number:</b> XXXXXXXXXXXX <b>Password:</b> Blank <b>DHCP:</b> Disable <b>IP Address:</b> 192.168.0.1 <b>Net Mask:</b> 255.255.255.0 <b>Gateway:</b> 192.168.0.254 <b>MAC Address:</b> Fixed – see bottom label <b>Port 1</b> Console Mode <b>Ports 2, 3, 4</b> RS-232 <b>Baud Rate:</b> 9600 <b>Data/Parity/Stop:</b> 8-N-1 <b>Flow Control:</b> None <b>TCP/UDP Ports:</b> TCP Port 1 – 4000 TCP Port 2 – 4001 TCP Port 3 – 4002 TCP Port 4 – 4003 <b>Connection Mode:</b> Server <b>Remote IP Address:</b> 255.255.255.255
<b>Optional Accessories</b>	<b>232NM9</b> Null Modem Crossover Cable for DTE to DTE connection <b>DRAD35</b> DIN Rail mounting clips for 35mm DIN Rail <b>ERS35</b> one-meter length of steel 35mm DIN Rail

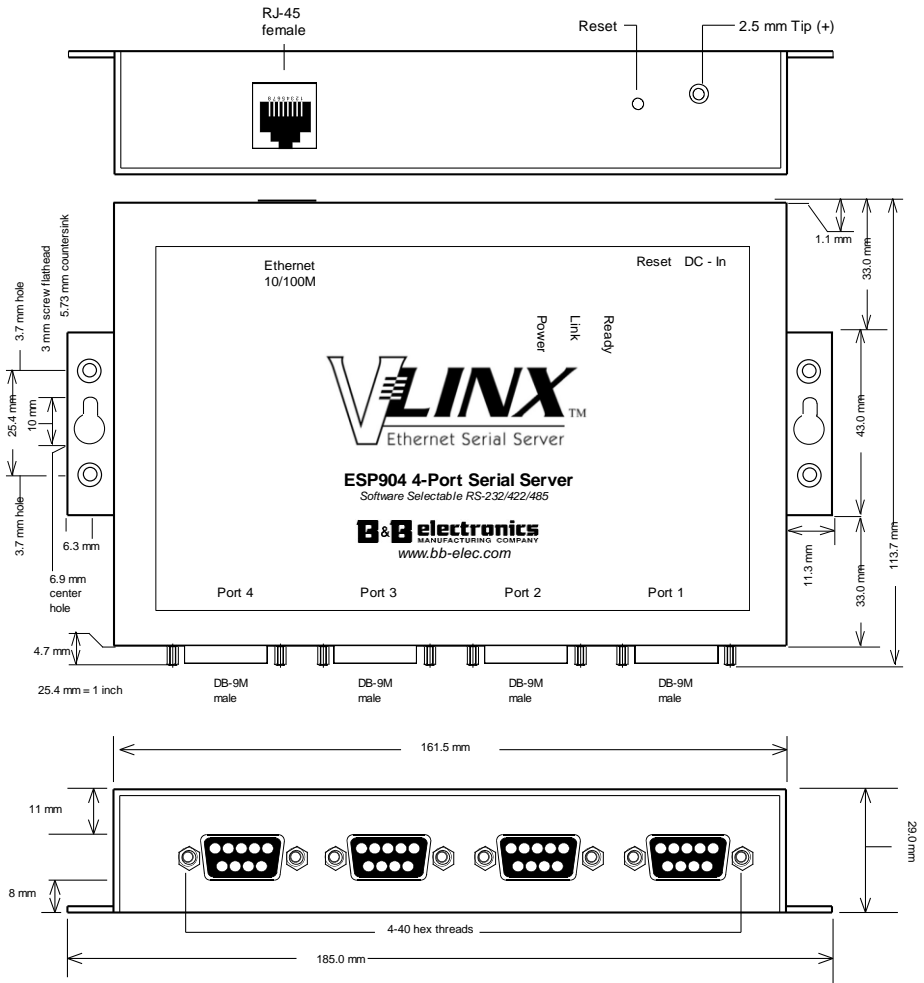

Figure 56. Dimensional Diagram of the ESP904



# APPENDIX A: RS-232 CONNECTIONS

## ESP904 DB-9 Pin-outs in RS-232 Mode

DB-9 Male  
outside

1 2 3 4 5

6 7 8 9

RS-232 Signal Name	DTE	RS-232	DB-9M Pin
Carrier Detect	In	DCD	1
Receive Data	In	RXD	2
Transmit Data	Out	TXD	3
Data Terminal Ready	Out	DTR	4
Signal Ground	---	GND	5
Data Set Ready	In	DSR	6
Request To Send	Out	RTS	7
Clear To Send	In	CTS	8
Ring Indicator	In	RI	9

Figure 57. RS-232 Connections in a DB-9 Connector

## RS-232 Straight-through Cable Connections

In the RS-232 mode, the ESP904's ports are configured as DTEs like a computer. If the device connected to the ESP904 is configured as a DCE use a straight through cable wired as shown below:

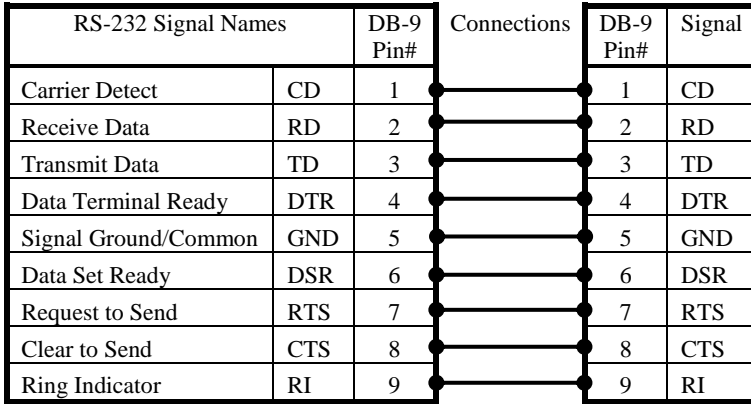

Figure 58. Straight-through DB-9 to DB-9 RS-232 Serial Cable

## RS-232 Crossover (null modem) Cable Connections

When connecting to a PC or another DTE device, use a crossover cable (also called a null modem cable).

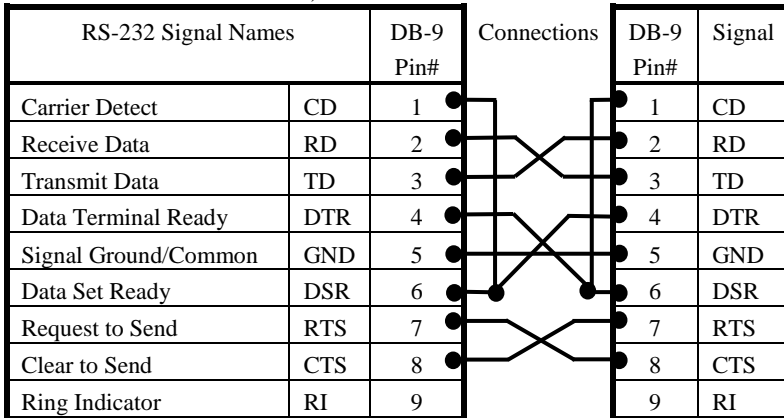

Figure 59. Crossover DB-9 to DB-9 RS-232 Serial Cable

## DB9 DTE to DCE DB25

RS-232 Signal Names	Pin#	Connections	Pin#	
Carrier Detector (DCD)	CD #1		#1	FGND
Receive Data (Rx)	RD #2		#2	TD
Transmit Data (Tx)	TD #3		#3	RD
Data Terminal Ready	DTR #4		#4	RTS
Signal Ground/Common (SG)	GND #5		#5	CTS
Data Set Ready	DSR #6		#6	DSR
Request to Send	RTS #7		#7	GND
Clear to Send	CTS #8		#8	CD
Ring Indicator	RI #9		#20	DTR
Soldered to DB9 Metal - Shield	FGND		#22	RI

Figure 60. DB-9 to DB-25 Straight-through Cable Connections

## RS-232 Crossover DB-9 to DB-25 Conversion Connections

## DB9 DTE to DTE DB25

RS-232 Signal Names	Pin#	Connections	Pin#	
Carrier Detector (DCD)	CD #1		#1	FGND
Receive Data (Rx)	RD #2		#2	TD
Transmit Data (Tx)	TD #3		#3	RD
Data Terminal Ready	DTR #4		#4	RTS
Signal Ground/Common (SG)	GND #5		#5	CTS
Data Set Ready	DSR #6		#6	DSR
Request to Send	RTS #7		#7	GND
Clear to Send	CTS #8		#8	CD
Ring Indicator	RI #9		#20	DTR
Soldered to DB9 Metal - Shield	FGND		#22	RI

Figure 61. DB-9 to DB-25 Crossover (null modem) Cable Connections

**RS-232 DTE Loopback Connections**

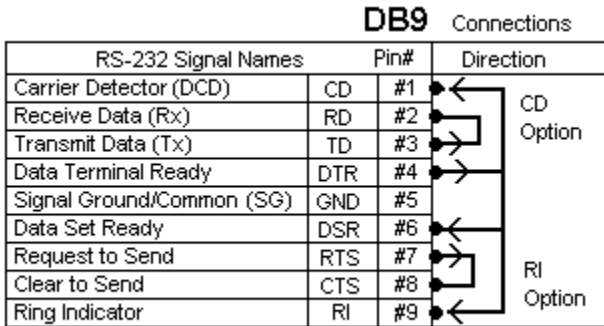

Figure 62. Loopback Connections for RS-232

For Transmit and Receive loopback, connect only those lines.

When Flow Control setting on the Serial Server is set for RTS/CTS, those lines must be looped. Usually DTR and DSR must also be looped. The Flow Control setting for the program must match the Server settings. The CD connection is needed by some terminal programs to simulate Carrier.



# APPENDIX B: RS-422 CONNECTIONS

## ESP904 DB-9 Pin-outs in RS-422 Mode

RS-422 Signal Name	Direction	RS-422	DB9M Pin
Receive Data A (-)	In	RXDA (-)	1
Receive Data B (+)	In	RXDB (+)	2
Transmit Data B (+)	Out	TXDB (+)	3
Transmit Data A (-)	Out	TXDA (-)	4
Signal Ground	---	GND	5
Clear to Send A (-)	In	CTSA (-)	6
Clear to Send B (+)	In	CTSB (+)	7
Request to Send B (+)	Out	RTSB (+)	8
Request to Send A (-)	Out	RTSA (-)	9

Figure 63. RS-422 Connections in a DB-9 Connector

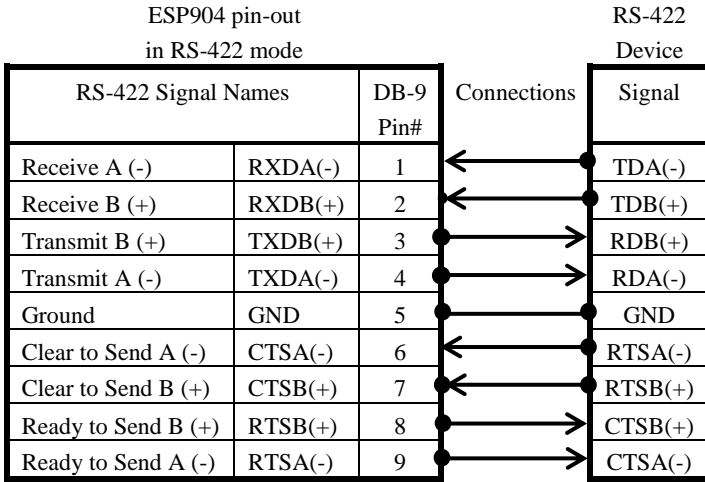

Figure 64. RS-422 Connections with Flow Control

In the RS-422 mode, TXD lines are outputs and RXD lines are inputs. Connect the ESP904 TXDB(+) line to the RXDB(+) line of the serial device, and the ESP904 TXDA(-) to the RXDA(-) of the serial device.

**If Flow Control is set for RTS/CTS**, connect the ESP904 RTSB(+) to CTSB(+) of the serial device and the ESP904 RTSA(-) line to the CTSA(-) of the serial device. Connect from the ESP904 CTSB(+) line to the RTSB(+) of the serial device and from the ESP904 CTSA(-) line to the RTSB(+) line of the serial device.

**If connecting to Receive Only** RS-422 devices, connect from the ESP904 TXDB(+) and TXDA(-) lines to the receive pairs on all serial devices.

Ground is signal ground and provides a common mode reference for the RS-422 Receiver and Transmitters.

**Note:**

The RS-422 mode can be used for full duplex 4-wire RS-485 operation provided that the ESP904 is acting as a sole master connecting to all the slave devices, and all slave devices share the Receive signal lines to the master. Set Flow Control for none, and omit connections to RTS/CTS line pairs.

## RS-422 Mode

Pin	Name
#3	TXDB(+)
#4	TXDA(-)
#2	RXDB(+)
#1	RXDA(-)
#8	RTSB(+)
#9	RTSA(-)
#7	CTSB(+)
#6	CTSA(-)
#5	GND

Figure 65. Loopback Connections for RS-422

The RS-485 Connections are half duplex, either Receive or Transmit, so another half duplex device must be used to check operation.

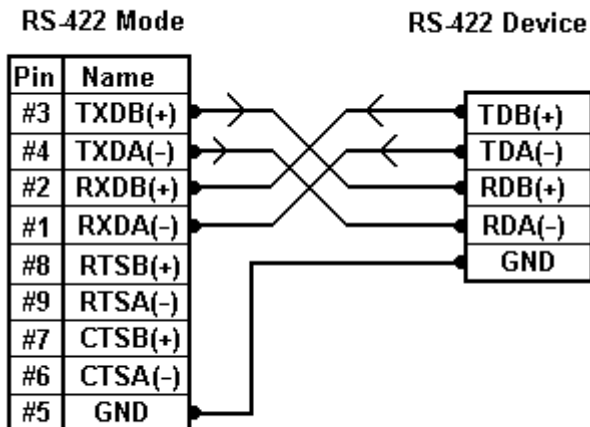

Figure 66. RS-422 Connection with No Flow Control



# APPENDIX C: RS-485 CONNECTIONS

## ESP904 DB-9 Pin-out in RS-485 Mode

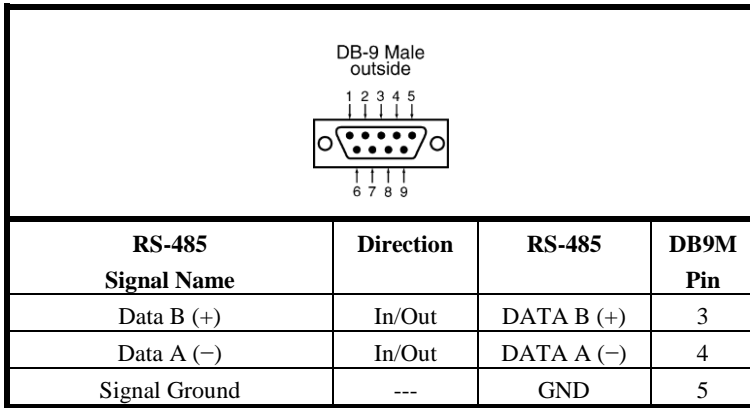

Figure 67. DB-9 Pin-out in RS-485 Mode

**Note:**

Some RS-485 devices are marked opposite the RS-485 standard, which defines the Data B line as positive relative to Data A during a Mark state before enabling the transmitter, and after transmitting before tri-stating. If an RS-485 device does not respond, try swapping the Data B and Data A lines.

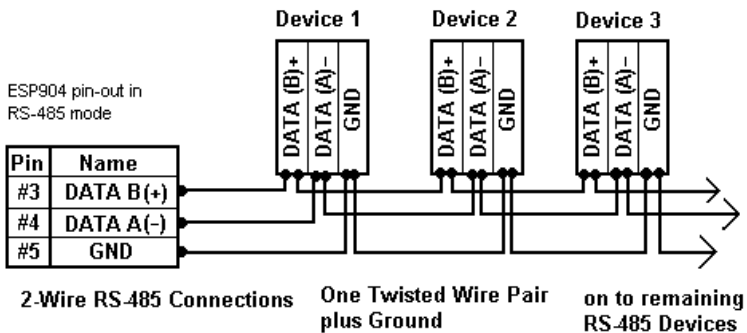

Figure 68. 2-wire RS-485 Connection

To connect 4-Wire RS-485 devices, the RS-422 Mode can be used provided the ESP904 will be connected as a master in a single master system. If using multiple masters, the ESP904 cannot be used, as it does not tri-state the transmitter in RS-422 mode.

# APPENDIX D: NETWORK CONNECTIONS

## Standard Ethernet Cable RJ-45 Pin-out

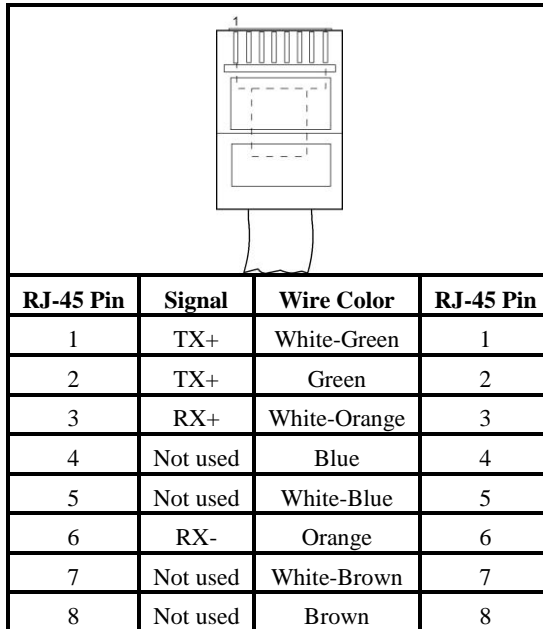

Figure 69. Pin-out for a Standard Ethernet Cable

## Crossover Ethernet Cable RJ-45 Pin-out

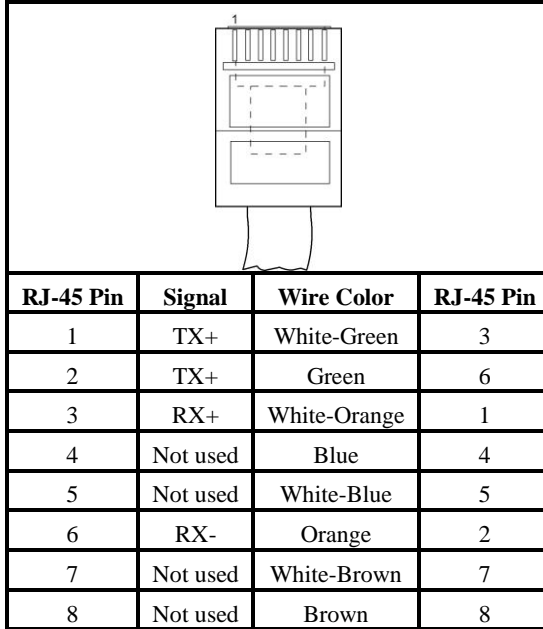

Figure 70. Pin-out for a Crossover Ethernet Cable





**International Headquarters**

B&B Electronics Mfg. Co. Inc.  
707 Dayton Road  
Ottawa, IL 61350 USA

**Phone** (815) 433-5100 -- **General Fax** (815) 433-5105

Website: [www.bb-elec.com](http://www.bb-elec.com)

**Sales e-mail:** [orders@bb-elec.com](mailto:orders@bb-elec.com) -- **Fax** (815) 433-5109

**Technical Support e-mail:** [support@bb.elec.com](mailto:support@bb.elec.com) -- **Fax** (815) 433-5104

**European Headquarters**

B&B Electronics Ltd.  
Westlink Commercial Park  
Oranmore, Co. Galway, Ireland

**Phone** +353 91-792444 -- **Fax** +353 91-792445

Website: [www.bb-europe.com](http://www.bb-europe.com)

**Sales e-mail:** [sales@bb-europe.com](mailto:sales@bb-europe.com)

**Technical Support e-mail:** [support@bb-europe.com](mailto:support@bb-europe.com)

© B&B Electronics – October 2005

