



KRAMER ELECTRONICS LTD.

# USER MANUAL

MODEL:

**Tavor 8-T (SPK-CA820)**

Active Ceiling Speaker

---

P/N: 2900-300343 Rev 2



## Tavor 8-T Quick Start Guide

This guide helps you install and use your product for the first time. For more detailed information, go to [http://www.kramerelectronics.com/support/product\\_downloads.asp](http://www.kramerelectronics.com/support/product_downloads.asp) to download the latest manual or scan the QR code on the left.

### Step 1: Check what's in the box

- Tavor 8-T Active Ceiling Speaker
- 1 60cm x 60cm grille
- 1 Quick start guide
- 24V DC Power adapter

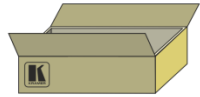

Save the original box and packaging materials in case you need to return your product for service.

### Step 2: Choose the best location

Determine the number of speakers that are required, locate them above the main listening area, making sure that:

- The mounting location is free of obstructions, such as electrical piping, AC ducts or water lines, and so on
- There is enough space behind the mounting surface for the speaker
- The rear side of the speaker is not blocked by wall studs or other objects

### Step 3: Install the speakers

To install the speakers:

- Move the pivoting tweeters to the correct angle
- Run the wires through the ceiling
- Remove the ceiling tile at the correct location
- Connect the speaker wires

Always switch OFF the power on each device before connecting it to your Speakers.

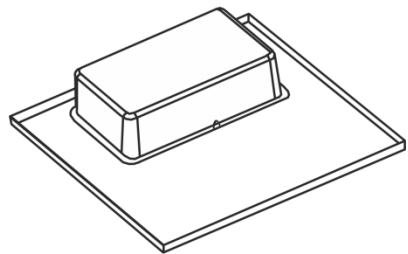
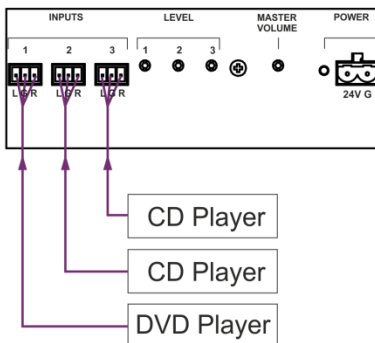

- Connect the power
- Place the speaker in its place temporarily, set the audio level, test the audio quality and adjust the position of the tweeter until you are satisfied with the results
- Fit the speaker, tighten the screws and attach the grille
- Secure the speaker to the ceiling

For best results, we recommend that you always use Kramer BCP-2S speaker cables to connect AV equipment to your speakers

# Contents

<b>1</b>	<b>Introduction</b>	<b>1</b>
<b>2</b>	<b>Getting Started</b>	<b>2</b>
2.1	Achieving the Best Performance	2
2.2	Safety Instructions	3
2.3	Recycling Kramer Products	3
<b>3</b>	<b>Overview</b>	<b>4</b>
3.1	Defining the Tavor 8-T	6
<b>4</b>	<b>Installing the Tavor 8-T</b>	<b>8</b>
4.1	Choosing the Best Location	8
4.2	Determining the Location of the Tavor 8-T	9
4.3	Preparing the Tavor 8-T for Operation	10
4.4	Installing the Tile Size Speaker	11
<b>5</b>	<b>Technical Specifications</b>	<b>13</b>

## Figures

Figure 1:	Tile Size ESD Ceiling Speaker (that fits into the ceiling)	5
Figure 2:	Tavor 8-T	6
Figure 3:	Tavor 8-T Side View	7
Figure 4:	Tavor 8-T vs. Standard Speakers	9
Figure 5:	Connecting the Inputs	10
Figure 6:	Fitting the Tile Size Speaker	11
Figure 7:	Securing the Speaker to a Ceiling Anchor Point	12

---

# 1 Introduction

Welcome to Kramer Electronics! Since 1981, Kramer Electronics has been providing a world of unique, creative, and affordable solutions to the vast range of problems that confront the video, audio, presentation, and broadcasting professional on a daily basis. In recent years, we have redesigned and upgraded most of our line, making the best even better!

Our 1,000-plus different models now appear in 14 groups that are clearly defined by function: GROUP 1: Distribution Amplifiers; GROUP 2: Switchers and Routers; GROUP 3: Control Systems; GROUP 4: Format/Standards Converters; GROUP 5: Range Extenders and Repeaters; GROUP 6: Specialty AV Products; GROUP 7: Scan Converters and Scalers; GROUP 8: Cables and Connectors; GROUP 9: Room Connectivity; GROUP 10: Accessories and Rack Adapters; GROUP 11: Sierra Video Products; GROUP 12: Digital Signage; GROUP 13: Audio; and GROUP 14: Collaboration.

Congratulations on purchasing your Kramer **Tavor 8-T** Active Ceiling Speaker, which is ideal for overhead distributed audio for professional applications (music and speech) and educational applications.



ESD™ (Equal Sound Dispersion) Ceiling Speakers are designed for indoor dry locations and are suitable for use in air handling spaces.

---

## 2 Getting Started

We recommend that you:

- Unpack the equipment carefully and save the original box and packaging materials for possible future shipment
- Review the contents of this user manual



Go to [http://www.kramerelectronics.com/support/product\\_downloads.asp](http://www.kramerelectronics.com/support/product_downloads.asp) to check for up-to-date user manuals, application programs, and to check if firmware upgrades are available (where appropriate).

### 2.1 Achieving the Best Performance

To achieve the best performance:

- Use only good quality connection cables (we recommend Kramer high-performance, high-resolution cables) to avoid interference, deterioration in signal quality due to poor matching, and elevated noise levels (often associated with low quality cables)
- Do not secure the cables in tight bundles or roll the slack into tight coils
- Avoid interference from neighboring electrical appliances that may adversely influence signal quality
- Position your Kramer **Tavor 8-T** away from moisture, excessive sunlight and dust



This equipment is to be used only inside a building. It may only be connected to other equipment that is installed inside a building.



Do not open the housing of the speaker; doing so may reduce the quality of the sound.

## 2.2 Safety Instructions



**Caution:** There are no operator serviceable parts inside the unit

**Warning:** Use only the Kramer Electronics input power wall adapter that is provided with the unit

**Warning:** Disconnect the power and unplug the unit from the wall before installing

## 2.3 Recycling Kramer Products

The Waste Electrical and Electronic Equipment (WEEE) Directive 2002/96/EC aims to reduce the amount of WEEE sent for disposal to landfill or incineration by requiring it to be collected and recycled. To comply with the WEEE Directive, Kramer Electronics has made arrangements with the European Advanced Recycling Network (EARN) and will cover any costs of treatment, recycling and recovery of waste Kramer Electronics branded equipment on arrival at the EARN facility. For details of Kramer's recycling arrangements in your particular country go to our recycling pages at <http://www.kramerelectronics.com/support/recycling/>.

---

## 3 Overview

The Kramer **Tavor 8-T** *Active Ceiling Speaker* is an active high-performance complete K-coverage™ ESD ceiling speaker that can be mounted in the ceiling and appears as a suspended ceiling tile. The **Tavor 8-T** accepts 3 line level stereo inputs and amplifies them using a built-in amplifier. Each audio input level can be adjusted independently and the overall volume can be adjusted via the master volume trimmer.

The **Tavor 8-T** is constructed with a central Kevlar(R) driver and four titanium pivoting tweeters and is housed in an enclosed shallow enclosure.

The Kramer **Tavor 8-T** provides unmatched sound response in a suspended ceiling device for the professional and educational markets. This means that you get the sound you need but with one speaker that replaces multiple standard speakers.

The ESD ceiling speaker features:

- A built-in 40W class D amplifier
- An 8" Kevlar(R) cone woofer
- 4 pivoting 0.75" titanium tweeters
- A shallow 4-inch depth (approx. 100mm)
- Excellent natural frequency response for music and high-quality voice reproduction
- A magnet held speaker grille (with 2 security screws) for time-saving installation
- A plastic ring to secure the wires to the speaker

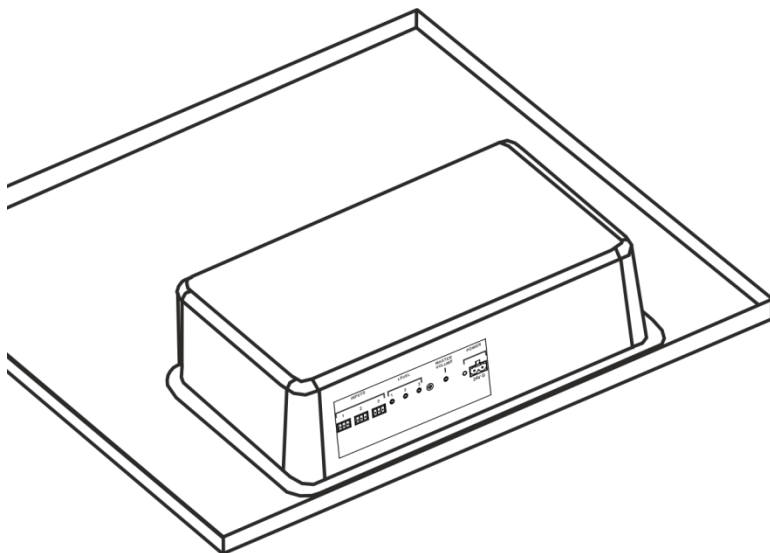

Figure 1: Tile Size ESD Ceiling Speaker (that fits into the ceiling)

The speaker is easily installed and is also available with a 60 X 60cm grille for the US and other markets, if required.



### 3.1 Defining the Tavor 8-T

Figure 2 defines the **Tavor 8-T**:

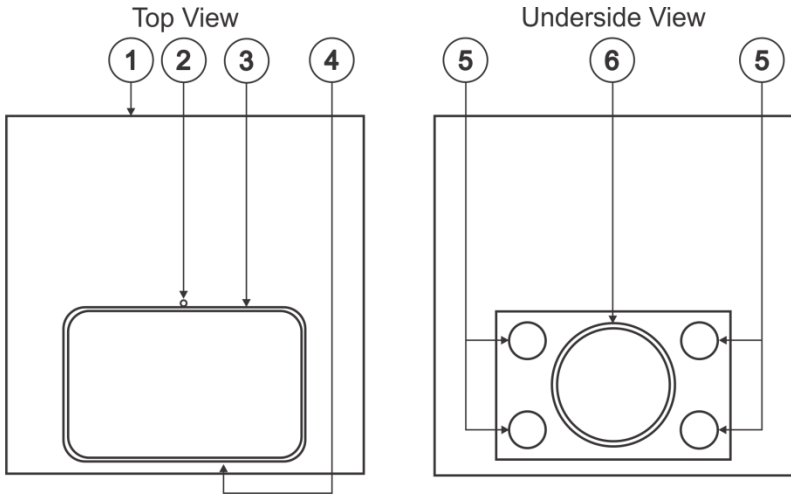

Figure 2: Tavor 8-T

#	Feature	Function
1	Speaker Tile Base	Half-tile size or tile size
2	Anchor Ring	Secure the speaker to the ceiling anchoring point
3	Speaker Steel Enclosure	Shallow fireproof enclosure
4	Control Panel	See <a href="#">Figure 3</a>
5	Tweeters (4)	Pivoting titanium
6	Woofer	Kevlar(R) surrounded by rubber

Figure 3 defines the **Tavor 8-T** side view:

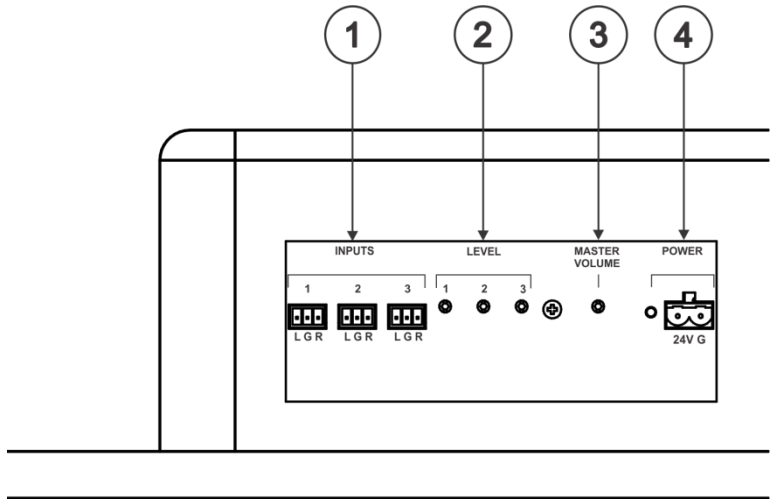

Figure 3: Tavor 8-T Side View

#	Feature	Function
1	INPUTS L,G,R Terminal Block Connectors (1 to 3)	Connect an audio source to the unbalanced stereo audio input
2	LEVEL Trimmers	Set the audio level on each input individually using a small screwdriver
3	MASTER VOLUME Trimmer	Set the audio level of the overall sound using a small screwdriver
4	POWER	24V to power the built in amplifier. Connect to the supplied power adapter

---

## 4 Installing the Tavor 8-T

This section explains how to install the **Tavor 8-T**, that is:

- Choosing the best place to locate your speaker (see [Section 4.1](#))
- Determining the location of the speaker (see [Section 4.2](#))
- Preparing the speaker for operation (see [Section 4.3](#))
- Installing the tile size speaker (see [Section 4.4](#))

### 4.1 Choosing the Best Location

Ideally, locate the speakers above the main listening area. Before doing so, be sure that:

- The desired location is free of obstructions, such as electrical piping, AC ducts or water lines, and so on
- There is enough space behind the mounting surface for the speaker
- The rear side of the speaker is not blocked by wall studs or other objects

## 4.2 Determining the Location of the Tavor 8-T

When installed in a room with a standard ceiling height of 2.7m (8.8 feet), the optimal distance between speakers is about 10 meters. The speaker should be installed lengthwise relative to the shape of the room. The example in [Figure 4](#) shows the **Tavor 8-T** installed in a 10m x 5m room.

This example also shows how the **Tavor 8-T** can actually replace several standard speakers in a room.

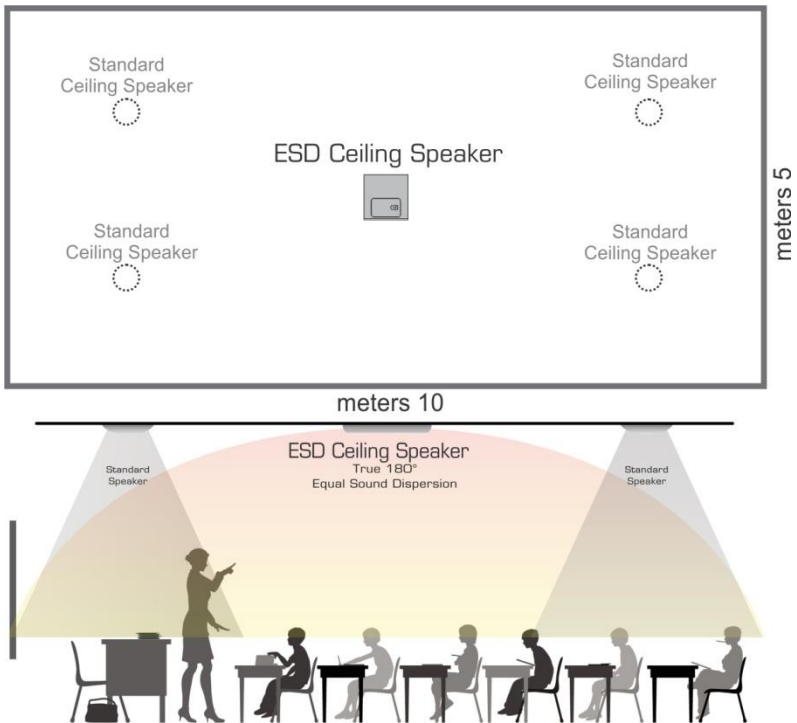

Figure 4: Tavor 8-T vs. Standard Speakers

### 4.3 Preparing the Tavor 8-T for Operation

Once the location of the speaker is fixed, prepare the speaker for operation as follows:

1. Move each of the pivoting tweeters outward in an angle that is suited to the room shape and size.
2. Run the wires through the ceiling.
3. Remove the ceiling tile at the place where you plan to install the speaker.
4. Connect the input wires to the speaker terminals (see [Figure 5](#)) from the adjacent ceiling tile opening as follows:
  - Connect the inputs as illustrated in the example in [Figure 5](#) (for example, a DVD player and two CD players). Connect the audio output terminals to the L, G and R INPUT terminal block connectors.

**Note: Do not ground the speakers.**

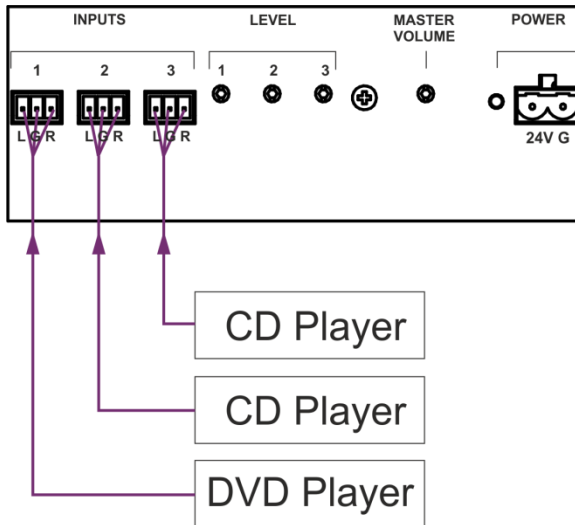

Figure 5: Connecting the Inputs

- Connect the 24V DC power adapter to the **Tavor 8-T** power socket and to the mains electricity.

5. Set the audio level independently per input and, if required, set the overall audio level via the MASTER VOLUME trimmer.
6. Place the speaker temporarily in place, and test the audio quality.
7. If you are not satisfied, change the position of the tweeters, set the audio levels and check the audio quality again until you are happy with the results.
8. Fit the speaker grille over the speaker underside and tighten with screws.

To install the tile size speaker, see [Section 4.4](#).

## 4.4 Installing the Tile Size Speaker

1. Drop the speaker into the ceiling tile space.  
Make sure that you position the speaker lengthwise relative to the room shape (see [Figure 6](#)).

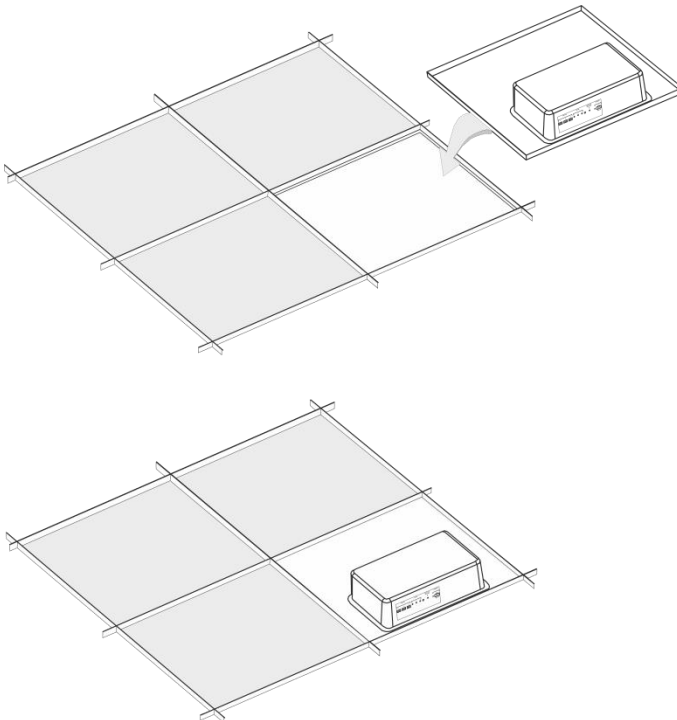

Figure 6: Fitting the Tile Size Speaker

2. Secure the speaker by connecting the speaker support ring to an independent secure ceiling anchor point (see [Figure 7](#)) as appropriate. The anchor prevents the speaker from falling if the tile itself comes out or falls apart.

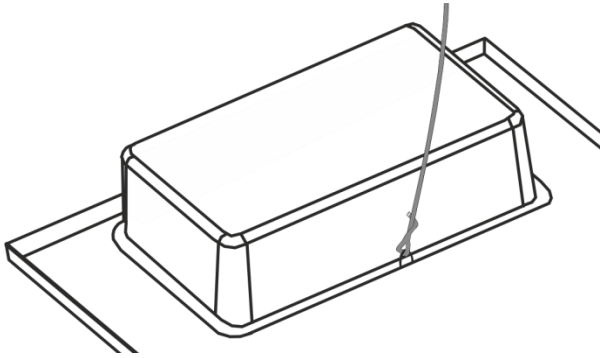

Figure 7: Securing the Speaker to a Ceiling Anchor Point



Do not over-tighten the screws. It may cause damage to both the speakers and the surface.

## 5 Technical Specifications

<b>Audio and Power</b>	
DESCRIPTION:	Active flat ceiling speaker
FREQUENCY RESPONSE:	65Hz to 20kHz @ -10dB 80Hz to 20kHz @ ±3dB
WOOFER:	8" (200mm) Kevlar(R) cone with rubber surround
TWEETER:	4 X 0.75" Titanium pivoting tweeters
SENSITIVITY:	87dB 1W @1m
MAX SPL:	Continuous: 102dB Peak: 105dB
POWER HANDLING:	40W RMS 110W continuous program
CROSSOVER FREQUENCY:	2kHz
DIRECTIVITY FACTOR (Q):	9.43, averaged 1kHz to 10kHz
DIRECTIVITY INDEX (DI)	9.5dB averaged 1kHz to 10kHz
INPUT CONNECTORS:	Terminal block connectors
CONTROLS:	3 independent input level trimmer, 1 master volume trimmer
<b>Shipping and Installation</b>	
MATERIALS:	Frame, steel grilles (595x595mm, 600x600mm), cable holder
DIMENSIONS:	60cm x 60cm x 10cm (tile size) 59.5cm x 59.5cm x 10cm (tile size) for any region with suspended ceiling tiles of 595mm
OPERATING TEMPERATURE:	0° to +40°C (32° to 104°F)
STORAGE TEMPERATURE:	-40° to +70°C (-40° to 158°F)
HUMIDITY:	10% to 90%, RHL non-condensing
WEIGHT:	8.8 kg (19.3lbs) approx.
SHIPPING WEIGHT:	10.5 kg (27.1lbs) approx.
ACCESSORIES:	24V DC power adapter, 2 available grilles (595x595mm, 600x600mm)
COLORS:	Available in white
Specifications are within a 10% tolerance and are subject to change without notice at <a href="http://www.kramerelectronics.com">http://www.kramerelectronics.com</a>	



## LIMITED WARRANTY

The warranty obligations of Kramer Electronics for this product are limited to the terms set forth below:

### What is Covered

This limited warranty covers defects in materials and workmanship in this product.

### What is Not Covered

This limited warranty does not cover any damage, deterioration or malfunction resulting from any alteration, modification, improper or unreasonable use or maintenance, misuse, abuse, accident, neglect, exposure to excess moisture, fire, improper packing and shipping (such claims must be presented to the carrier), lightning, power surges, or other acts of nature. This limited warranty does not cover any damage, deterioration or malfunction resulting from the installation or removal of this product from any installation, any unauthorized tampering with this product, any repairs attempted by anyone unauthorized by Kramer Electronics to make such repairs, or any other cause which does not relate directly to a defect in materials and/or workmanship of this product. This limited warranty does not cover cartons, equipment enclosures, cables or accessories used in conjunction with this product.

Without limiting any other exclusion herein, Kramer Electronics does not warrant that the product covered hereby, including, without limitation, the technology and/or integrated circuit(s) included in the product, will not become obsolete or that such items are or will remain compatible with any other product or technology with which the product may be used.

### How Long Does this Coverage Last

One year as of this printing; please check our Web site for the most current and accurate warranty information.

### Who is Covered

Only the original purchaser of this product is covered under this limited warranty. This limited warranty is not transferable to subsequent purchasers or owners of this product.

### What Kramer Electronics will do

Kramer Electronics will, at its sole option, provide one of the following three remedies to whatever extent it shall deem necessary to satisfy a proper claim under this limited warranty:

1. Elect to repair or facilitate the repair of any defective parts within a reasonable period of time, free of any charge for the necessary parts and labor to complete the repair and restore this product to its proper operating condition. Kramer Electronics will also pay the shipping costs necessary to return this product once the repair is complete.
2. Replace this product with a direct replacement or with a similar product deemed by Kramer Electronics to perform substantially the same function as the original product.
3. Issue a refund of the original purchase price less depreciation to be determined based on the age of the product at the time remedy is sought under this limited warranty.

### What Kramer Electronics will not do Under This Limited Warranty

If this product is returned to Kramer Electronics or the authorized dealer from which it was purchased or any other party authorized to repair Kramer Electronics products, this product must be insured during shipment, with the insurance and shipping charges prepaid by you. If this product is returned uninsured, you assume all risks of loss or damage during shipment. Kramer Electronics will not be responsible for any costs related to the removal or re-installation of this product from or into any installation. Kramer Electronics will not be responsible for any costs related to any setting up this product, any adjustment of user controls or any programming required for a specific installation of this product.

### How to Obtain a Remedy under this Limited Warranty

To obtain a remedy under this limited warranty, you must contact either the authorized Kramer Electronics reseller from whom you purchased this product or the Kramer Electronics office nearest you. For a list of authorized Kramer Electronics resellers and/or Kramer Electronics authorized service providers, please visit our web site at [www.kramerelectronics.com](http://www.kramerelectronics.com) or contact the Kramer Electronics office nearest you.

In order to pursue any remedy under this limited warranty, you must possess an original, dated receipt as proof of purchase from an authorized Kramer Electronics reseller. If this product is returned under this limited warranty, a return authorization number, obtained from Kramer Electronics, will be required. You may also be directed to an authorized reseller or a person authorized by Kramer Electronics to repair the product.

If it is decided that this product should be returned directly to Kramer Electronics, this product should be properly packed, preferably in the original carton, for shipping. Cartons not bearing a return authorization number will be refused.

### Limitation on Liability

THE MAXIMUM LIABILITY OF KRAMER ELECTRONICS UNDER THIS LIMITED WARRANTY SHALL NOT EXCEED THE ACTUAL PURCHASE PRICE PAID FOR THE PRODUCT. TO THE MAXIMUM EXTENT PERMITTED BY LAW, KRAMER ELECTRONICS IS NOT RESPONSIBLE FOR DIRECT, SPECIAL, INCIDENTAL OR CONSEQUENTIAL DAMAGES RESULTING FROM ANY BREACH OF WARRANTY OR CONDITION, OR UNDER ANY OTHER LEGAL THEORY. Some countries, districts or states do not allow the exclusion or limitation of relief, special, incidental, consequential or indirect damages, or the limitation of liability to specified amounts, so the above limitations or exclusions may not apply to you.

### Exclusive Remedy

TO THE MAXIMUM EXTENT PERMITTED BY LAW, THIS LIMITED WARRANTY AND THE REMEDIES SET FORTH ABOVE ARE EXCLUSIVE AND IN LIEU OF ALL OTHER WARRANTIES, REMEDIES AND CONDITIONS, WHETHER ORAL OR WRITTEN, EXPRESS OR IMPLIED. TO THE MAXIMUM EXTENT PERMITTED BY LAW, KRAMER ELECTRONICS SPECIFICALLY DISCLAIMS ANY AND ALL IMPLIED WARRANTIES, INCLUDING, WITHOUT LIMITATION, WARRANTIES OF MERCHANTABILITY AND FITNESS FOR A PARTICULAR PURPOSE. IF KRAMER ELECTRONICS CANNOT LAWFULLY DISCLAIM OR EXCLUDE IMPLIED WARRANTIES UNDER APPLICABLE LAW, THEN ALL IMPLIED WARRANTIES COVERING THIS PRODUCT, INCLUDING WARRANTIES OF MERCHANTABILITY AND FITNESS FOR A PARTICULAR PURPOSE, SHALL APPLY TO THIS PRODUCT AS PROVIDED UNDER APPLICABLE LAW.

IF ANY PRODUCT TO WHICH THIS LIMITED WARRANTY APPLIES IS A "CONSUMER PRODUCT" UNDER THE MAGNUSON-MOSS WARRANTY ACT (15 U.S.C.A. §2301, ET SEQ.) OR OTHER APPLICABLE LAW, THE FOREGOING DISCLAIMER OF IMPLIED WARRANTIES SHALL NOT APPLY TO YOU, AND ALL IMPLIED WARRANTIES ON THIS PRODUCT, INCLUDING WARRANTIES OF MERCHANTABILITY AND FITNESS FOR THE PARTICULAR PURPOSE, SHALL APPLY AS PROVIDED UNDER APPLICABLE LAW.

### Other Conditions

This limited warranty gives you specific legal rights, and you may have other rights which vary from country to country or state to state.

This limited warranty is void if (i) the label bearing the serial number of this product has been removed or defaced, (ii) the product is not distributed by Kramer Electronics or (iii) this product is not purchased from an authorized Kramer Electronics reseller. If you are unsure whether a reseller is an authorized Kramer Electronics reseller, please visit our Web site at [www.kramerelectronics.com](http://www.kramerelectronics.com) or contact a Kramer Electronics office from the list at the end of this document.

Your rights under this limited warranty are not diminished if you do not complete and return the product registration form or complete and submit the online product registration form. Kramer Electronics thanks you for purchasing a Kramer Electronics product. We hope it will give you years of satisfaction.



For the latest information on our products and a list of Kramer distributors, visit our Web site where updates to this user manual may be found.

**We welcome your questions, comments, and feedback.**

Web site: [www.kramerelectronics.com](http://www.kramerelectronics.com)

E-mail: [info@kramerel.com](mailto:info@kramerel.com)

CE



**SAFETY WARNING**

Disconnect the unit from the power supply before opening and servicing



P/N: 2900-300343



Rev: 2