

A table listed below shall be suggested for reference on install & it's assumed object monitor mounting holes located at the center position, relative to the monitor screen. Installer/user may adjust them accordingly if those holes are located off center (e.g. vertically, etc.)

**Step 1** **Mounting Heights (Reference Table)**

* Screen Size	4x3		16x9	
	Seated	Standing	Seated	Standing
15"	34.1" (866 mm)	50.1" (1273 mm)	34.9" (886 mm)	50.9" (1293 mm)
16"	33.8" (859 mm)	49.8" (1265 mm)	34.6" (879 mm)	50.6" (1285 mm)
18.1"	33.1" (841 mm)	49.1" (1247 mm)	34.1" (866 mm)	50.1" (1273 mm)
20"	32.6" (828 mm)	48.6" (1234 mm)	33.7" (856 mm)	49.7" (1262 mm)
21"	32.3" (820 mm)	48.3" (1227 mm)	33.4" (848 mm)	49.4" (1255 mm)
22"	32" (813 mm)	48" (1219 mm)	33.2" (843 mm)	49.2" (1250 mm)
24"	31.4" (798 mm)	47.4" (1204 mm)	32" (813mm)	48.7" (1237 mm)

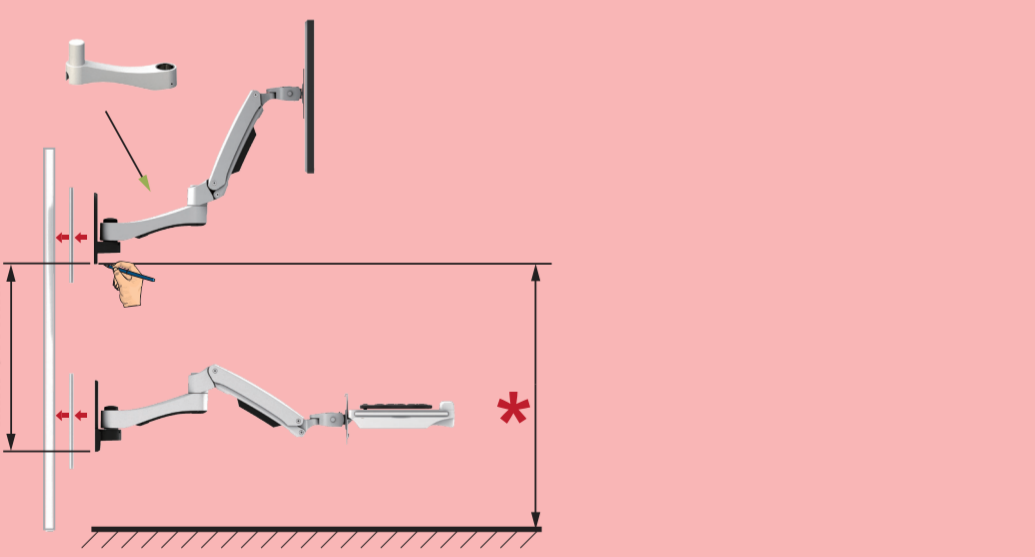
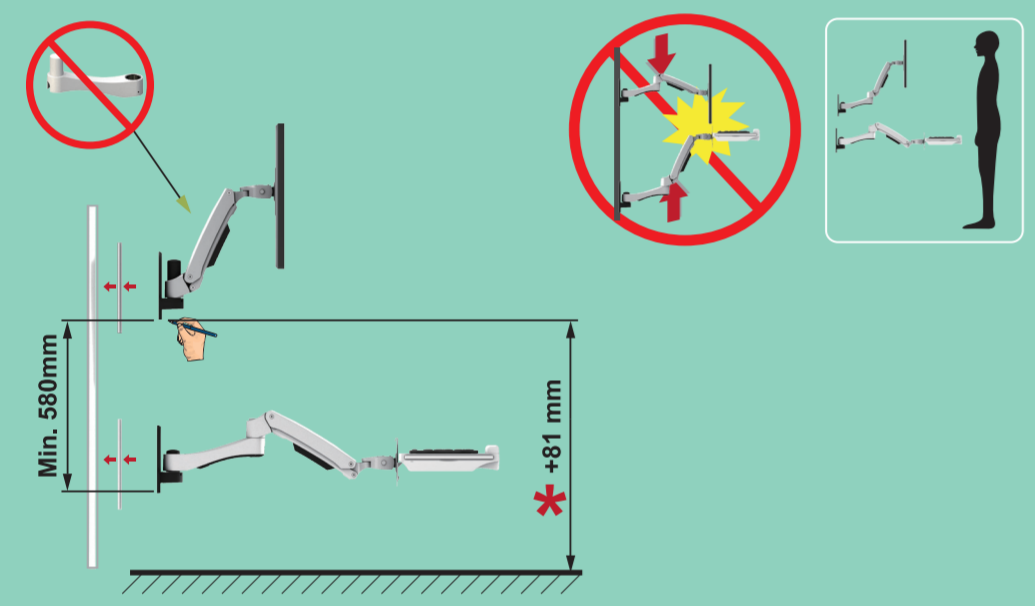

**Step 2** **Stud Walls**  
 Note: For a stud wall, holes of 4.5mm diameter and 55mm depth shall be made.

