

Safety

Warning: Due to variety of mounting surface material, it is imperative that you make sure mounting surface is strong enough to handle mounted product and equipment.

WARNING
DO NOT place hands on or near support bars. Pinch points are created during lifting and lowering the worksurface. Failure to follow these instructions may result in serious personal injury.

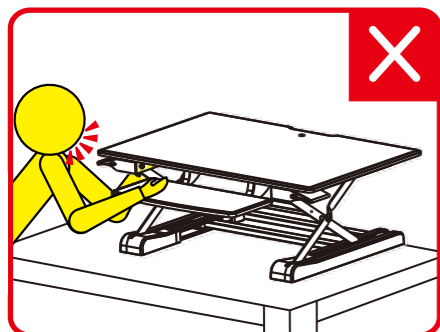

Warning: Impact Hazard! On the working surface under tension, moving parts can be squeezed and cut. Lift up the worksurface to its top position before removing the device. Not paying attention to this warning can lead to serious personal injury and property damage!

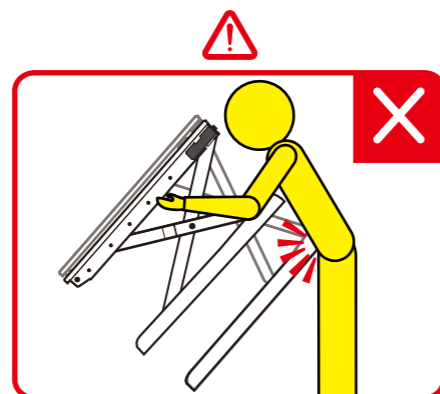

Warning: Impact Hazard! Moving parts can be squeezed and cut. Lift the product to its top position before raising off the desk. Need two people to lift this product away from desk. Do not tip the product side or upside down. The product must always remain upright. Please pay attention to these warnings, may lead to unexpected movements of the lifting mechanism may result in serious personal injury and property damage.

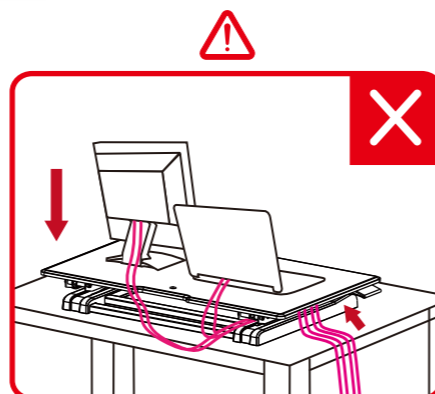

Caution: In order to avoid the potential of the pinch cable it is important to follow the instructions of the cable management in this manual. If you do not follow these instructions, may cause damage to equipment or personal injury.

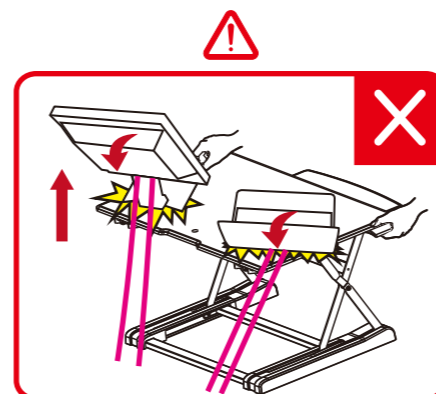

Caution: Leave enough slack in cable to allow for full range of vertical motion. Failure to follow this warning may result in property damage and or personal injury.



Caution: Keep the display and notebook computer base fully inside the worksurface. Hanging any part of the base or stand on the edge may cause property damage or personal injury.

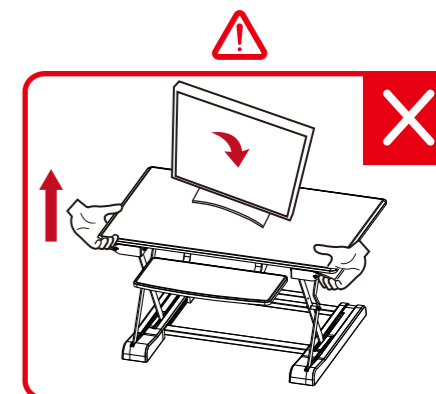

Caution: Lift up worksurface slowly. Lifting up worksurface too fast may create an unstable situation resulting in property damage and or personal injury.

包裝零件 / Enclosed Parts / 梱包部品及びアクセサリ / Parties cloisonnées / Medföljande delar / Mitgelieferte Teile / Componentes suministrados / Peças incluídas / Załączane Części / Enclosed части / Parti incluse / 동봉한 부품

安裝步驟及方式 / Installation / Process / 取り付け方法 / Méthode d'installation / Installationsvorgang / Proceso de instalación / Processo da instalação / Proces Instalacji / Процесс установки / Processo di installazione / Installationsprocess / 설치 과정

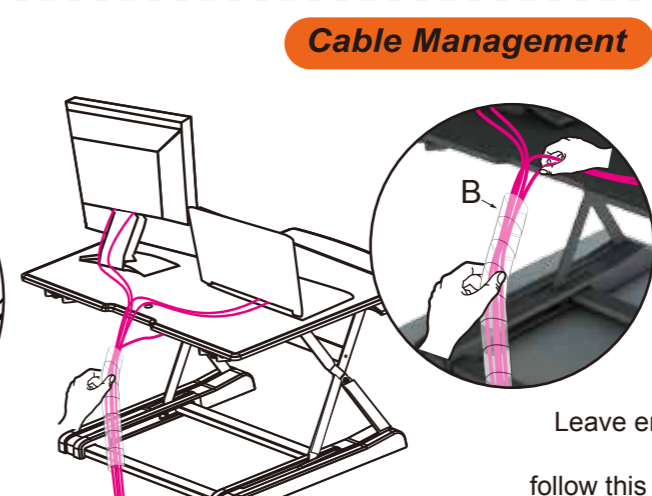
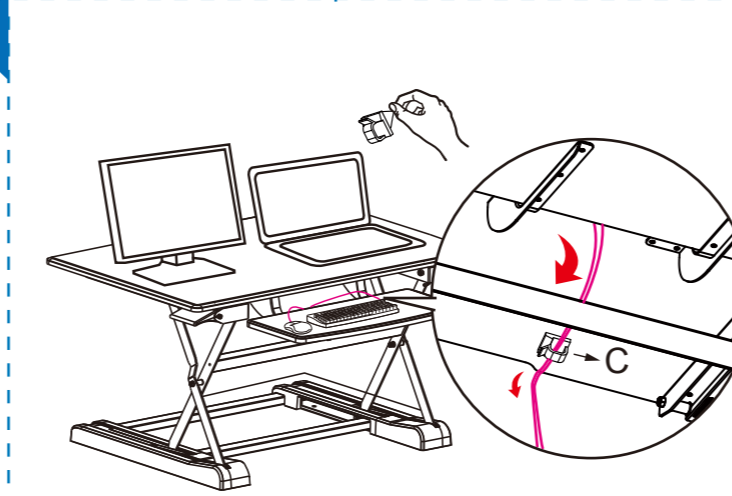
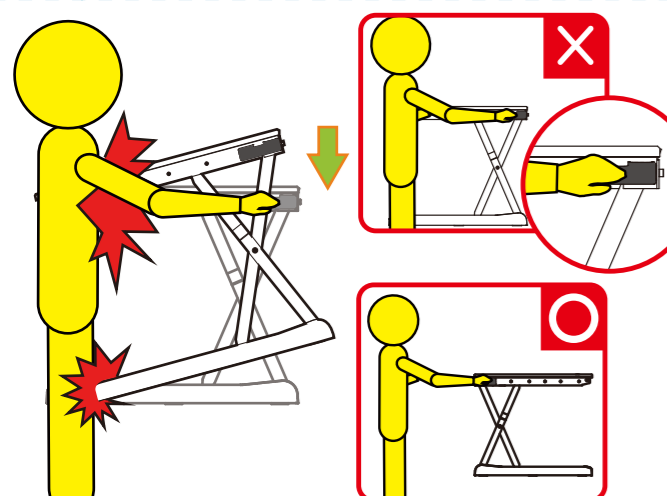
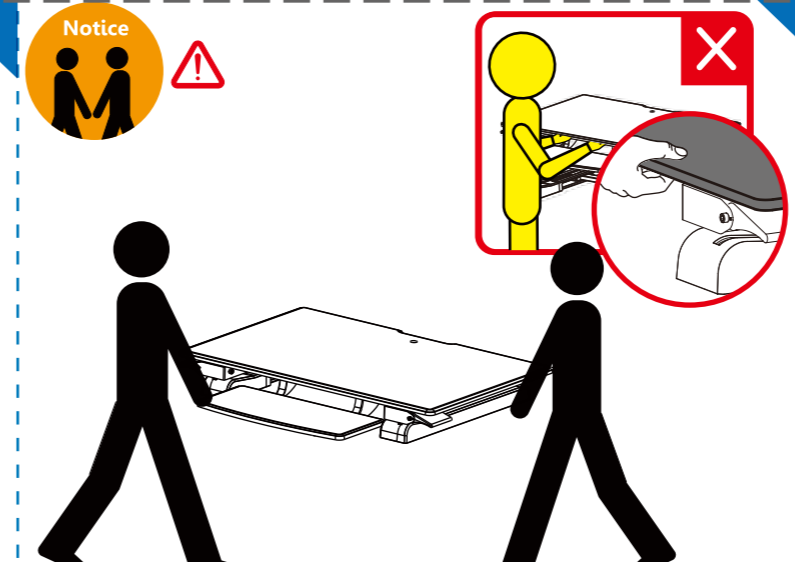
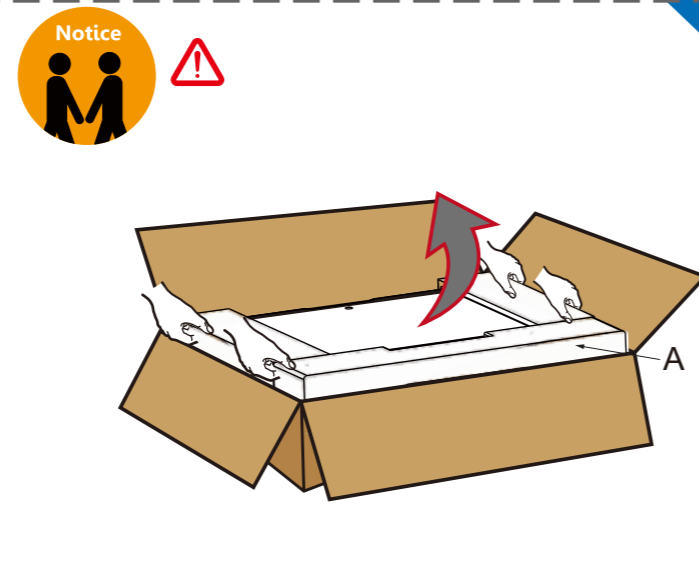
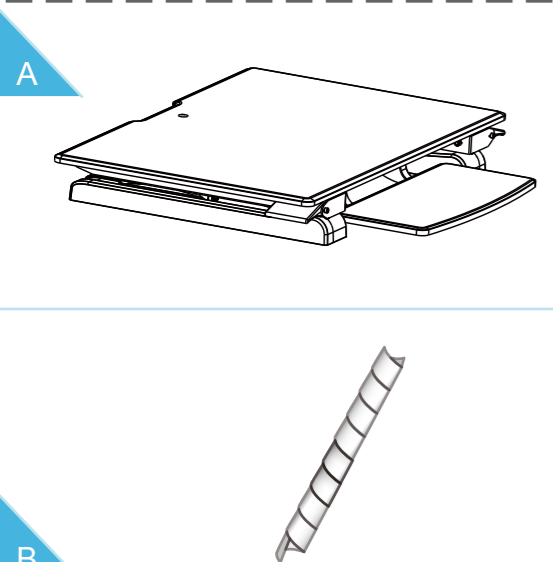

Cable Management

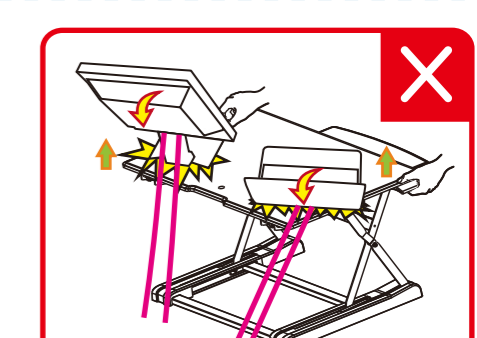

Caution: Leave enough slack in cable to allow for full range of vertical motion. Failure to follow this warning may result in property damage and or personal injury.

