

# SonicWall® SonicWave 681

## Quick Start Guide

Regulatory Model Number:  
APL66-106



Copyright © 2022 SonicWall Inc. All rights reserved.

SonicWall is a trademark or registered trademark of SonicWall Inc. and/or its affiliates in the U.S.A. and/or other countries. All other trademarks and registered trademarks are property of their respective owners.

The information in this document is provided in connection with SonicWall Inc. and/or its affiliates' products. No license, express or implied, by estoppel or otherwise, to any intellectual property right is granted by this document or in connection with the sale of SonicWall products. EXCEPT AS SET FORTH IN THE TERMS AND CONDITIONS AS SPECIFIED IN THE LICENSE AGREEMENT FOR THIS PRODUCT, SONICWALL AND/OR ITS AFFILIATES ASSUME NO LIABILITY WHATSOEVER AND DISCLAIMS ANY EXPRESS, IMPLIED OR STATUTORY WARRANTY RELATING TO ITS PRODUCTS INCLUDING, BUT NOT LIMITED TO, THE IMPLIED WARRANTY OF MERCHANTABILITY, FITNESS FOR A PARTICULAR PURPOSE, OR NON-INFRINGEMENT. IN NO EVENT SHALL SONICWALL AND/OR ITS AFFILIATES BE LIABLE FOR ANY DIRECT, INDIRECT, CONSEQUENTIAL, PUNITIVE, SPECIAL OR INCIDENTAL DAMAGES (INCLUDING, WITHOUT LIMITATION, DAMAGES FOR LOSS OF PROFITS, BUSINESS INTERRUPTION OR LOSS OF INFORMATION) ARISING OUT OF THE USE OR INABILITY TO USE THIS DOCUMENT, EVEN IF SONICWALL AND/OR ITS AFFILIATES HAVE BEEN ADVISED OF THE POSSIBILITY OF SUCH DAMAGES. SonicWall and/or its affiliates make no representations or warranties with respect to the accuracy or completeness of the contents of this document and reserves the right to make changes to specifications and product descriptions at any time without notice. SonicWall Inc. and/or its affiliates do not make any commitment to update the information contained in this document.

For more information, visit <https://www.SonicWall.com/legal/>.

### Legend

- WARNING:** A WARNING icon indicates a potential for property damage, personal injury, or death.
- CAUTION:** A CAUTION icon indicates potential damage to hardware or loss of data if instructions are not followed.
- IMPORTANT, NOTE, TIP, MOBILE, or VIDEO:** An information icon indicates supporting information.

To access the Support Portal, go to <https://www.SonicWall.com/support>.

SonicWave 681 Quick Start Guide  
Updated - February 2022  
232-005725-50 Rev A



## 1 Introduction

This *SonicWall® SonicWave 681 Quick Start Guide* provides instructions for basic installation and configuration of SonicWall SonicWave 681 wireless access points. The SonicWall SonicWave 681 is a ceiling-mountable wireless access point suitable for indoor single-unit or multi-unit deployments. It is plenum rated for installation within an enclosed space such as an attic. It can also be mounted on a wall or deployed on a shelf, table, or desktop. Power over Ethernet (PoE) should be provided to power the SonicWave 681.

## 2 SonicWave 681 Hardware Overview

### SonicWave 681



### SonicWave 681 Hardware Components

Component	Description
2.4GHz and 5GHz radios	Dual radios provide: <ul style="list-style-type: none"> <li>802.11b/g/n/ac</li> <li>DFS (Dynamic Frequency Selection)</li> </ul> SonicWave 681 complies with FCC rules to detect and avoid interfering with radar signals in DFS bands. <ul style="list-style-type: none"> <li>2x2 11n + 2x2 11ac wave 2 MU-MIMO</li> </ul>
1GbE LAN port	1 Ethernet 10/100/1000 LAN port for wired connection to a SonicWall network security appliance
USB port	1 USB 2.0 port
Scanning radio	Dedicated third scanning radio
Antennas	5 internal (2.4GHz x 2 / 5GHz x 2 / Scan Radio x 1)
Power source	802.3bt type 3 PoE (standard, PoE device sold separately) Optional DC 12V power adapter, sold separately

### SonicWave 681 Hardware Components (Continued)

Component	Description
Chassis	Rectangle 119mm x 214mm x 34mm Plenum rated
Kensington security slot	For use with a Kensington locking cable to prevent theft
Operating temperature	0° to 40°C

## 3 SonicWave 681 Ports

The back of the SonicWave 681 provides a LAN/POE port where the PoE Ethernet cable connects the access point with the PoE injector or PoE-enabled switch, which connects to your SonicWall network security appliance.

A 12V power connection is also provided on the back of the unit, where you can plug in a 12V adapter (sold separately) to power the device.

### SonicWave 681 Back

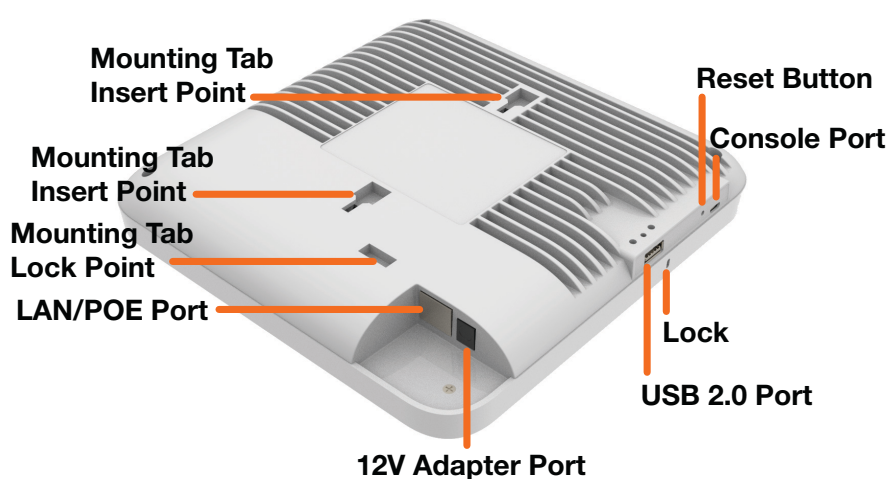

When the access point is installed, the back panel is attached to the ceiling or to a wall or other flat surface.

The side panel of the SonicWave 681 has the LED indicators and the USB port.

### SonicWave 681 LEDs

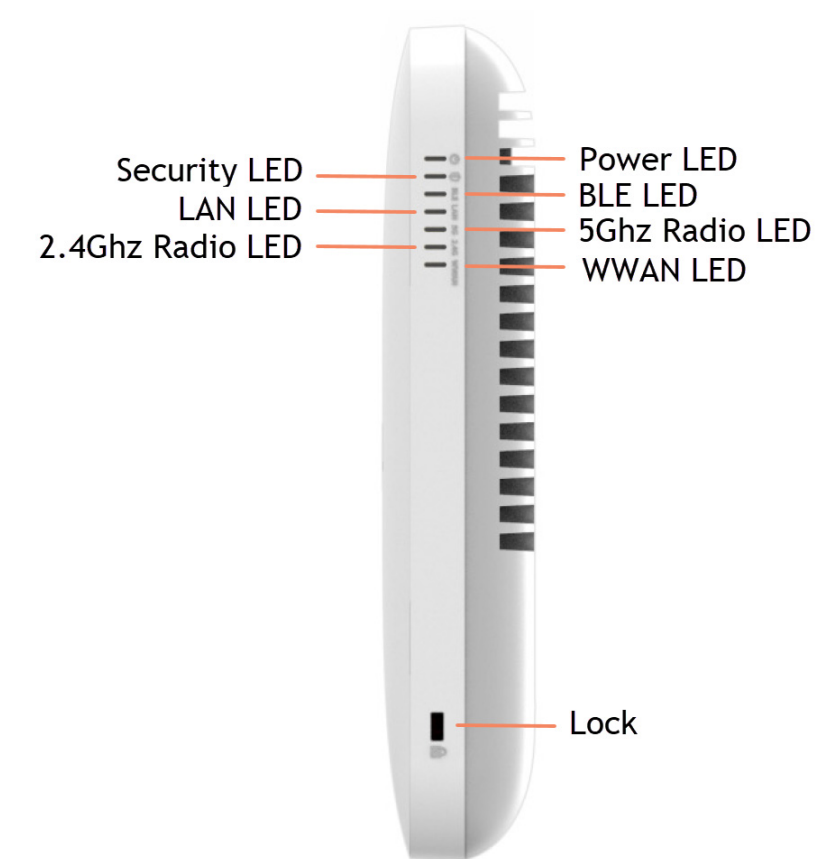

You can insert a 3G/4G USB modem into the USB port to create a mobile wireless (MiFi) hotspot. See the *SonicOS Administration* documentation for information about the MiFi Extender feature. You can also use the USB port with a USB security clamp.

For information about the LEDs, see the [SonicWave 681 LED Activity](#) section.

## 4 Checking Package Contents

Before you begin the setup process, verify that your package contains the following items:

- SonicWave 681 appliance
- Mounting plate, screws and anchors
- CAT5e cable
- SonicWall SonicWave 681 Quick Start Guide*
- Safety, Regulatory and Legal Information* document

### Package Contents



If any items are missing from the package, contact SonicWall Technical Support at: <https://www.SonicWall.com/support/contact-support>.

**NOTE:** The PoE device for powering the SonicWave 681 is sold separately and is not included in the package.

## 5 Deployment Requirements

### SonicOS Firmware

SonicWall SonicWave 681 access points are centrally managed by SonicWall network security appliances running the following versions of SonicOS:

- SonicOS 7.1.x or higher

### Power Source

Use a 802.3bt type 3 compliant PoE injector or a PoE enabled switch to provide power to each SonicWave 681.

### Internet Connectivity

An active Internet connection is required for your SonicWall network security appliance to download the latest SonicWave 681 firmware.

### Gigabit Ethernet Connectivity

The SonicWave 681 requires a 5 Gigabit connection to the SonicWall network security appliance to take full advantage of the SonicWave 681 data throughput capability.

## 6 Deployment Considerations

Physical placement of the SonicWave 681 wireless access point has a measurable effect on who can and cannot access your wireless signal. If too many users are serviced by a single access point, maximum transfer rates are reached and that access point may become a bottleneck for the whole system.

A site survey can help find the optimum wireless access point placement, but you can find usable locations without it.

RF barriers can be circumvented by deploying multiple access points. Determining how to circumvent RF barriers can be a challenging part of the placement process, but RF barriers can also be used beneficially in an attempt to block signals where you do not want coverage. The 5 GHz frequency is more sensitive to RF barriers. A wall that allows a 2.4 GHz wireless network to operate can block a 5 GHz one.

### Common RF Barrier Types

Barrier Type	RF Signal Blocking
Glass, wood, drywall, cube partitions	Low
Floors and outer walls, aquariums (brick/marble/granite/water)	Medium
Concrete, security glass, wire mesh, stacked books/paper	High
Metal partitions, desks, reinforced concrete	Very High

## 7 Installing the Mounting Bracket

The SonicWave 681 comes with a mounting bracket so it can be mounted on the ceiling or other flat surface. This section describes how to attach the mounting bracket to the ceiling or an indoor wall.

The mounting bracket provides two pairs of T-bar locking tabs that support two ceiling T-bar widths: 15/16 inch and 9/16 inch.

### Mounting Bracket Top

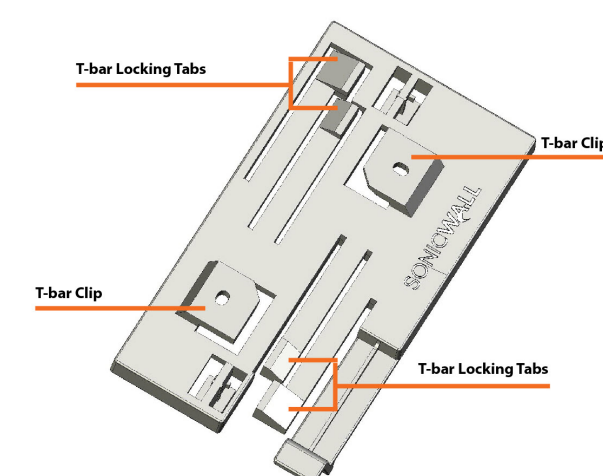

### Mounting Bracket Bottom

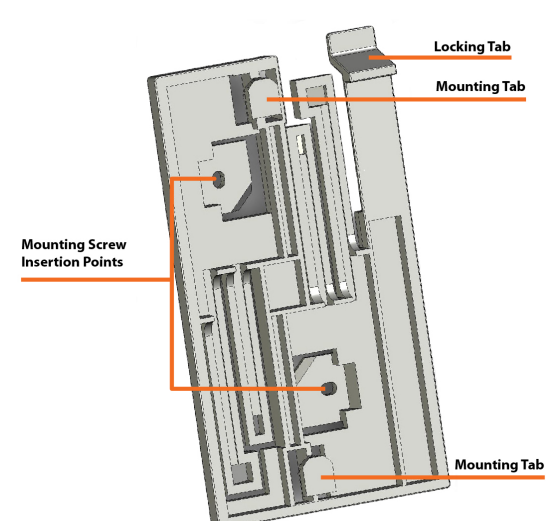

### To attach the mounting bracket to the ceiling using T-bar clips:

- Press the top side of the mounting bracket against the ceiling tile T-bar so that the T-bar locking tabs on the mounting bracket are depressed.
- Rotate the mounting bracket so the ceiling T-bar slides into the T-bar clips on the mounting bracket and the T-bar locking tabs click into place.

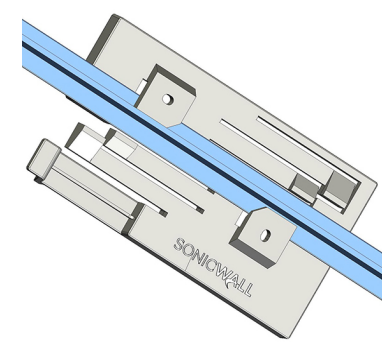

### To attach the mounting bracket to the ceiling or to a wall using screws:

- Place the top side of the mounting bracket against the ceiling or wall and mark the locations for the two screw insertion points.
- Drill starter holes at the marked locations. For a wood wall, use a drill bit that fits the provided screws. For drywall, use a drill bit that fits the anchors.
- For drywall, screw in the anchors.
- Place the mounting bracket against the wall with the holes lined up on the marks or anchors.
- Using the provided screws and a screwdriver, securely attach the mounting bracket to the ceiling or wall.

## 8 Configuring the Firewall for Wireless Access

This section provides instructions for configuring SonicOS on your SonicWall network security appliance to connect your SonicWave 681 to the WLAN zone and manage it as a Layer 2 device. This includes:

- [Configuring the SonicWave Provisioning Profile](#) for radio frequency, mode, authentication type
- [Configuring the Network Interface](#) to which the SonicWave 681 connects
- [Configuring the WLAN Zone](#) for trust, security, and SonicWave provisioning profile

### Configuring the SonicWave Provisioning Profile

SonicWave provisioning profiles include all of the settings that can be configured on a SonicWave 681 access point. The profile is then selected when you configure the wireless zone (WLAN by default). When your SonicWave 681 connects to that zone, it is automatically provisioned with the profile settings.

### To configure the SonicWave provisioning profile:

- Log into your SonicWall firewall as an administrator (default: *admin / password*).
- Navigate to the **DEVICE | External Controllers | Access Points > Settings** page.
- In the **Access Point Provisioning Profiles** section, do one of the following:
  - To modify the default SonicWave profile, click the **Edit Profile** icon after hovering in the SonicWave row.
  - To create a new profile, select **SonicWave Profile** from the **Add New Profile** drop-down menu.

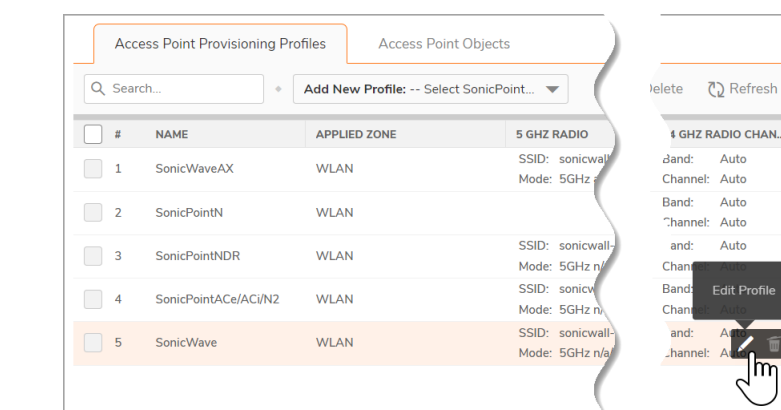

The **Add/Edit SonicWave Profile** dialog displays.

### General screen settings:

- Select **Enable**. This is selected by default.

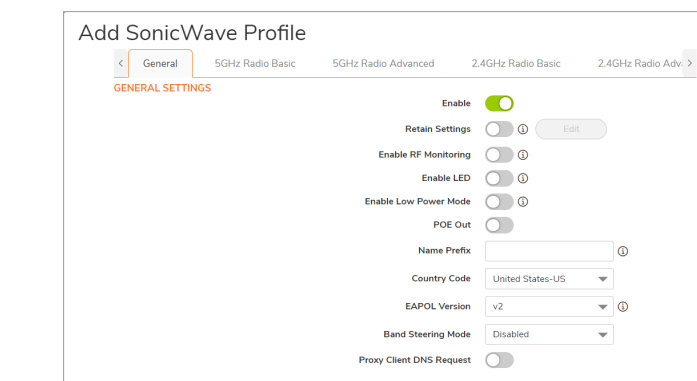

- To turn on the LEDs for SonicWaves using this provisioning profile, select **Enable LED**. The LEDs are turned off by default.
- If adding a new profile, type a simple, descriptive name into the **Name Prefix** field to assist in identifying the SonicWave in this zone. This is the name of the provisioning profile. Each provisioned SonicWave is named with this prefix followed by a unique number. Optionally change the **Name Prefix** if editing the default SonicWave profile.
- Verify the **Country Code** for the area of operation.

- Accept the defaults or configure the remaining options as necessary.

### Radio Basic Settings:

- Click **5GHz Radio Basic**.

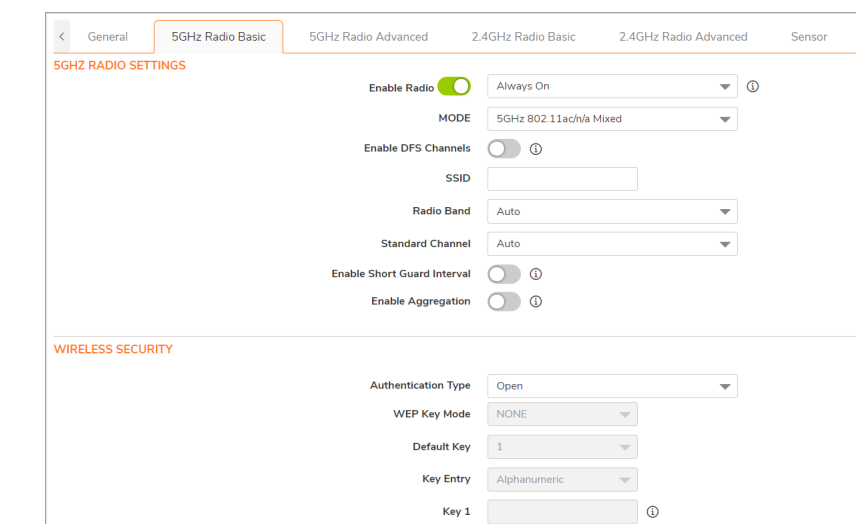

- Select **Enable Radio**. This is selected by default.
- Select a **MODE** or use the default.
- Type a short, descriptive name into the **SSID** field. This is the access point name that appears in clients' lists of available wireless connections.
- Under **Wireless Security**, select the **Authentication Type** for your wireless network. SonicWall recommends using **WPA2** as the authentication type if all client devices support it. **PSK** uses a passphrase for authentication, **EAP** uses an Enterprise RADIUS server.
- Select the **Cipher Type**. When using WPA and WPA2, SonicWall recommends **AES** for maximum security if all client devices support it.
- Fill in the fields specific to the authentication type that you selected. The remaining fields change depending on the selected authentication type.
- Click **2.4GHz Radio Basic** and repeat **Step 2** through **Step 7**.

### Radio Advanced Settings:

- Click **5GHz Radio Advanced**.

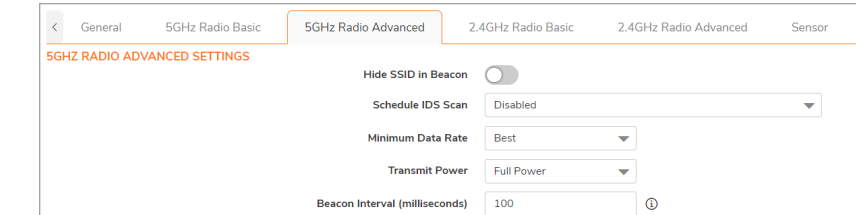

- For most advanced options, the default settings give optimum performance.

- Optionally select the **Hide SSID in Beacon** checkbox. The SSID refers to the access point name that appears in clients' lists of available wireless connections. Hiding the SSID provides additional security because it requires the user to know the access point name before connecting.
- Click **2.4GHz Radio Advanced** and repeat **Step 3**.
- When finished configuring all options, click **OK**.

For information about configuring the other options and screens in the **Add/Edit SonicWave Profile** dialog, see the *SonicOS Administration* documentation.

## Configuring the Network Interface

Each SonicWave or group of SonicWaves must be connected to a physical network interface that is configured in a wireless zone. SonicOS provides a standard wireless zone (WLAN) that can be applied to any available interface.

To configure the network interface in SonicOS:

- Navigate to the **NETWORK | System > Interfaces** page and click the **Edit this interface** icon by hovering over the interface to which your SonicWave connects.

- Select **WLAN** or another (custom) wireless zone from the **Zone** drop-down menu. The default wireless zone is **WLAN**.
- Select **Static IP Mode** for the **Mode/IP Assignment**.
- In the **IP Address** field, type in any private IP address that does not interfere with the IP address range of any other interfaces on the appliance. Wireless clients are assigned an IP address in this subnet.
- Enter a **Subnet Mask**. The default is 255.255.255.0.
- Select a non-zero number for **SonicPoint/SonicWave Limit**. If **0** is selected, no access points can be discovered on this interface.
- Use the default settings or select appropriate settings for the other fields and click **OK**.

## Configuring the WLAN Zone

To configure the WLAN zone in SonicOS:

- Navigate to **OBJECT | Match Objects > Zones** page, click the **Edit** icon in the WLAN row.
- On the **General** screen, select the **Allow Interface Trust** option to automate the creation of Access Rules to allow traffic to flow between the interfaces within the zone, regardless of the interfaces to which the zone is applied.

For example, if the WLAN zone has both the X2 and X3 interfaces assigned to it, selecting **Allow Interface Trust** creates the necessary access rules to allow hosts on these interfaces to communicate with each other.

- Select the checkboxes to enable security services on this zone. Minimally, you would select **Enable Gateway Anti-Virus Service**, **Enable IPS**, and **Enable Anti-Spyware Service**. If your wireless clients are all running SonicWall Client Anti-Virus, select **Enable Client AV Enforcement Service**.
- In the **Guest Services** screen, optionally configure guest Internet access. For information about Guest Services, see the *SonicOS Administration* documentation.
- In the **Wireless** screen under **SonicPoint/SonicWave Settings**, select the desired provisioning profile from the **SonicWave Provisioning Profile** drop-down menu. If you added a new profile in **Configuring the SonicWave Provisioning Profile**, select it here.

- Select **Only allow traffic generated by a SonicPoint/SonicWave** to allow only traffic from SonicWall wireless access points to enter the WLAN zone interfaces, providing maximum security.
- When finished, click **Save**.

You are now ready to connect your SonicWave 681 to your SonicWall network security appliance as described in the following sections.

## 9 Installing the SonicWave 681

This section describes how to connect the PoE and network cables and then attach the SonicWave 681 to the mounting bracket.

The SonicWave 681 connects to a WLAN zone interface on your SonicWall network security appliance. The access point is powered through Power over Ethernet (PoE), with the PoE device positioned between the SonicWave 681 and the firewall. SonicWall recommends using CAT5e Ethernet cables to connect the devices.

- CAUTION:** An 802.3bt type 3 compliant PoE injector or PoE enabled switch is required to provide power to each SonicWave 681. To maintain power to the SonicWave 681, the maximum length of CAT5e cable from the PoE device to the SonicWave 681 is 100 meters (333 feet).

To connect the SonicWave 681 to PoE and the network:

- Using an Ethernet cable, connect the **Data** in port on the PoE Injector to an existing WLAN zone interface on the firewall or to an unused interface to be configured later in SonicOS.
- Using a second Ethernet cable, connect the **Data and Power Out** port on the PoE injector to the **LAN/POE** port on your SonicWave 681. Refer to your *PoE Installation Guide* for more information.
- Plug the power cord of the PoE Injector into an appropriate power outlet.
- Wait up to two minutes for the **LAN LED** on the SonicWave 681 to illuminate. This indicates an active connection.

To attach the SonicWave 681 to the mounting bracket:

- Line up the two mounting tab insert points on the back of the SonicWave 681 with the mounting tabs on the mounting bracket.

- Insert the mounting tabs into the SonicWave 681 and slide the access point down until the locking tab on the bracket clicks into place on the SonicWave.

### Connecting the SonicWave 681

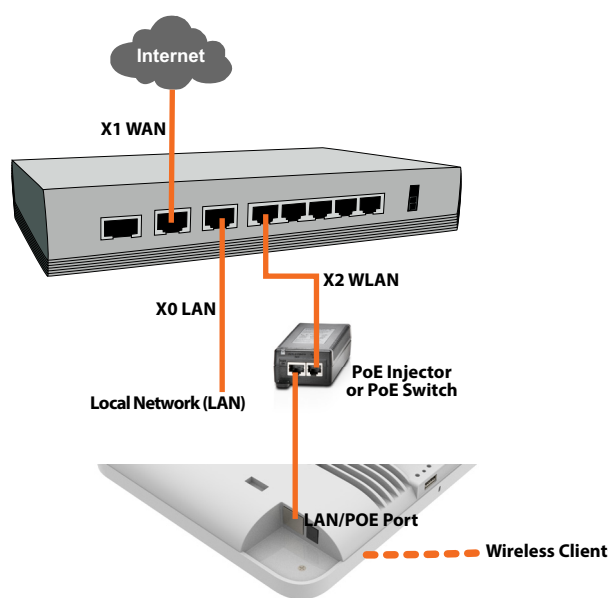

## 10 Verifying SonicWave Operation

To verify that the SonicWave is provisioned and operational:

- Log into your SonicWall firewall as an administrator (default: *admin / password*).
- Navigate to the **DEVICE | External Controllers > Access Points > Settings** page.
- In the **Access Point Objects** table, the **Status** column displays the SonicWave 681 status. It might display *Initializing*, *Updating Firmware*, *Writing Firmware*, and *Rebooting*. After rebooting, the **Status** should display *Operational*. If the **Status** displays *Operational (Not Licensed)* and does not change to *Operational* soon, contact SonicWall Support for assistance with licensing the SonicWave.
- Connect a client device to the SonicWave by selecting the appropriate access point name (SSID).
- Ensure that the client device is not connected to any other network connections (wired LAN, 3G/4G WWAN).
- In a browser, enter "https://www.SonicWall.com/" in the address bar and press **Enter**. The SonicWall website should display. If you are unable to browse to a website, refer to **Troubleshooting Tips**.

## 11 Troubleshooting Tips

When the SonicWave 681 is connected to a SonicWall network security appliance, the two units perform an encrypted exchange, and an entry for the SonicWave 681 is automatically created in the **SonicPoint/SonicWave Objects** table. Navigate to the **DEVICE | External Controllers > Access Points > Settings** page in SonicOS.

If the entry does not appear in the table within five minutes of connecting the SonicWave 681:

- Make sure the SonicWave 681 is connected to an interface that is configured as part of a wireless zone. Either the default WLAN zone or a custom zone with type set to "wireless" is required.
- Ensure that the SonicWave 681 is properly connected with an Ethernet cable to an 802.3bt type 3 compliant PoE device.
- If an 802.3bt type 3 compliant PoE injector is being used, verify that the SonicWave 681 is connected to the PoE port labeled **Data & Power Out**.
- If the SonicWave 681 has an entry in the table, but reboots frequently or seems non-functional:
  - Verify that your PoE switch/injector is 802.3bt type 3 compliant and rated to deliver sufficient power to each PoE port. 802.3af compliant PoE devices do not provide sufficient power to properly run current generation 802.11 devices.
  - Click **Synchronize Access Points** on the **DEVICE | External Controllers > Access Points > Settings** page to force SonicOS to download a new SonicWave firmware image from the SonicWall back-end server.

If the SonicWave becomes unresponsive or seems erratic, you can use the **Reset** button to reset the SonicWave to factory default settings or put it into **SafeMode**. Use a narrow, straight object, like a straightened paper clip to press the **Reset** button.

- To reboot the SonicWave with factory default settings, press **Reset** for three seconds until three LEDs begin to flash slowly. If the SonicWave is connected to your firewall, it reboots again after the provisioning profile settings are applied.
- To reboot the SonicWave into **SafeMode**, press **Reset** for eight seconds until three LEDs begin flashing at a medium rate.

See the **LED Pattern for Reset Button Hold Durations** and **LED Pattern in SafeMode** tables for more information.

- TIP:** **SafeMode** allows you to log into the SonicWave directly at 192.168.1.20 (default: *admin/password*) to manually update the firmware in rare situations when other troubleshooting fails. Contact SonicWall Support for assistance.

### 5 GHz Radio LED

LED Color	Description
Off	5 GHz radio is off
Solid Green	5 GHz radio is on
Blinking Green	Active traffic on 5 GHz radio

### 2.4 GHz Radio LED

LED Color	Description
Off	2.4 GHz radio is off
Solid Green	2.4 GHz radio is on
Blinking Green	Active traffic on 2.4 GHz radio

### LED Pattern During Firmware or SafeMode Bootup

LEDs	LED Color	Description
LAN	Green - Heartbeat	The three LEDs blink simultaneously in a heartbeat pattern while booting is in progress:
5 GHz Radio	Green - Heartbeat	
2.4 GHz Radio	Green - Heartbeat	On - On - Off

### LED Pattern for Reset Button Hold Durations

LEDs	LED Color	Description
LAN	Blinking Green	The three LEDs blink simultaneously at a slow or medium rate:
5 GHz Radio	Blinking Green	<ul style="list-style-type: none"> <li>Slow blink – Press Reset button 3 sec</li> </ul>
2.4 GHz Radio	Blinking Green	<ul style="list-style-type: none"> <li>Med blink – Press Reset button 8 sec</li> </ul>

### LED Pattern in SafeMode

LEDs	LED Color	Description
LAN	Green - Flow	The three LEDs turn on serially (one by one) and then turn off serially in a flow pattern while the SonicWave 681 is in <b>SafeMode</b> .
5 GHz Radio	Green - Flow	
2.4 GHz Radio	Green - Flow	

- NOTE:** The LEDs are disabled by default. You can enable them in the SonicWave provisioning profile or individual SonicWave entry in SonicOS on the firewall.

## 12 SonicWave 681 LED Activity

The SonicWave 681 LEDs provide essential status information about the access point.

### Power LED

LED Color	Description
Off	No power
Blue	Power is on

### Security LED

LED Color	Description
Green	All security services licensed
Blinking Yellow	Security services license expired. Security services monitored by this LED: Gateway Anti-Virus, Intrusion Prevention, Anti-Spyware

### Bluetooth Low Energy (BLE) LED

LED Color	Description
Green	On: Bluetooth has paired successfully. Blinking: Bluetooth is ready for pairing.
Off	Bluetooth is not paired.

### LAN LED

LED Color	Description
Off	No link
Solid Yellow	Link established at 1 Gbps, 2.5 Gbps, or 5Gbps
Blinking Yellow	Active traffic at 1 Gbps
Solid Green	Link established at 100 Mbps or 10 Mbps
Blinking Green	Active traffic at 100 Mbps or 10 Mbps