

SURFACE MODIFICATION BY ELECTRO-DISCHARGE COATING (EDC) WITH TiC-Cu P/M ELECTRODE TOOL

THIS THESIS IS ACQUIESCED IN THE PARTIAL FULLFILLMENT OF THE

REQUIREMNT FOR THE DEGREE OF

BACHELOR OF TECHNOLOGY IN MECHANICAL ENGINEERING

BY

RAKESH RANJAN

MECHANICAL ENGINEERING

(Roll No. 110ME0319)

UNDER THE SUPERVISION OF PROF. M. MASANTA



National Institute of Technology, Rourkela

SURFACE MODIFICATION BY ELECTRO-DISCHARGE COATING (EDC) WITH TiC-Cu P/M ELECTRODE TOOL

THIS THESIS IS ACQUIESCED IN THE PARTIAL FULLFILLMENT OF THE

REQUIREMNT FOR THE DEGREE OF

BACHELOR OF TECHNOLOGY IN MECHANICAL ENGINEERING

BY

RAKESH RANJAN

MECHANICAL ENGINEERING

(Roll No. 110ME0319)

UNDER THE SUPERVISION OF PROF. M. MASANTA



National Institute of Technology, Rourkela



National Institute of Technology, Rourkela

Certificate

This is to certify that the thesis entitled “**Surface Modification by Electro-Discharge Coating (EDC) with TiC-Cu P/M Electrode Tool**” being submitted by RAKESH RANJAN (110ME0319) for the partial fulfillment of the requirements of **Bachelor of Technology degree in Mechanical engineering** is a bona fide thesis work done by him under my supervision during the academic year 2013-2014, in the Department of Mechanical Engineering, National Institute of Technology Rourkela, India.

The results presented in this thesis have not been submitted elsewhere for the award of any other degree or diploma.

Date:

(Prof.M.MASANTA)

Mechanical Engineering,

National Institute of Technology, Rourkela

Acknowledgment

I would like to prompt my sincere gratefulness to my guide Prof. Manoj Masanta, Mechanical Engineering , NIT Rourkela, for giving me the open door to work with him and additionally giving brilliant direction time to time and ceaseless help all around the project work. His consistent guidance, attestations, consolation were exceptionally imperative and unavoidable, giving us that help without which it might not have been conceivable for me to complete this project. I am appreciative to him for his thankfulness all around the undertaking.

I additionally wish to express my profound sense of appreciation to Dr .K. P. Maity, HOD, Mechanical Engineering, NIT Rourkela for providing for me an open door to deal with this task and important departmental offices. I might be exceptionally obliged to stretch out my gratitude to Dr. U. K. Mohanty, HOD, Metallurgy and Materials Science Engineering for his enormous help and help rendered by providing for me the consents to utilize their laboratory for completing my experiments, without which the consummation of this undertaking might have been in question . I might additionally want to thank all the staffs of Mechanical Engineering Dept., NITR and everybody who somehow has given me significant direction, recommendation and help for this task.

Date:

RAKESH RANJAN (110ME0319)

B.Tech,

Mechanical Engineering,

National Institute of Technology, Rourkela

CONTENTS

<i>Preface</i>	<i>Page numbers</i>
Certificate	3
Acknowledgements	4
Contents	5-6
List of figures	7
List of Tables	8
Abstract	9
<i>Chapter 1</i>	<i>Introduction</i>
Introduction	10-12
<i>Chapter 2</i>	<i>Literature Survey</i>
Literature Survey	13-16
<i>Chapter 3</i>	<i>Objective and schedule</i>
Objective of the present work	17
Schedule of the work	17
<i>Chapter 4</i>	<i>Methodology Adopted</i>
4.1 Green compact sintered powder metallurgy (P/M) tool preparation	18
4.2 Electro Discharge coating (EDC) with P/M tool on mild steel by using EDM	19
<i>Chapter 5</i>	<i>Experimental Planning and Procedures</i>
5.1 Selection of tool material	20
5.2 Selection of workpiece material	20
5.3 Selection of process parameters	21
5.4 Preparation of tool electrode	22-23
5.5 Work-pieces preparation	23
5.6 Electro Discharge coating (EDC) with P/M tool on mild steel by using EDM	24
5.7 Experimental Procedures	25

5.8 Experimental condition of EDC process	26
---	----

<i>Chapter 6</i>	<i>Results and Discussions</i>
-------------------------	---------------------------------------

6.1 Experimental Details	27
6.2 Micro-hardness Test	28-29
6.3 Surface Roughness of mild steel coated with Cu+TiC	30
6.4 Effect of different parameters on deposition rate	30-32
6.5 Effect of different parameters on tool wear rate	32-33
6.6 Effect of different parameters on microhardness	33-34
6.7 Effect of different parameters on Surface Roughness	35-36
6.8 XRD Analysis	36-37

<i>Chapter 7</i>	<i>Conclusions</i>
-------------------------	---------------------------

Conclusions	37
References	38-39

List of figures

Figure No.	Description	Page No
Fig 1	Schematic diagram of EDC	11
Fig 4.1	Schematic diagram and typical setup of powder metallurgy power press	18
Fig 4.2	Sintering Setup	19
Fig 5.1	Front view of compacted tool	22
Fig 5.2	Top view of compacted tool	22
Fig 5.3	Tool electrode extension before and after joined with powder compressed pellet	23
Fig 5.4	Tool Electrode	23
Fig 5.5	AISI 1020 mild steel workpieces prepared for coating	24
Fig 5.6	Experimental Setup for EDC	25
Fig 6.1	AISI mild steel coated with TiC-Cu	27
Fig 6.2	Micro-Hardness Tester	28
Fig 6.3	Effect of peak current on deposition rate	31
Fig 6.4	Effect of T_{on} on deposition rate	32
Fig 6.5	Effect of peak current on tool wear rate	32
Fig 6.6	Effect of T_{on} on tool wear rate	33
Fig 6.7	Effect of peak current on micro-hardness	34
Fig 6.8	Effect of T_{on} on microhardness	34
Fig 6.9	Effect of peak current on surface roughness	35
Fig 7.0	Effect of T_{on} on surface roughness	36
Fig 7.1	XRD plot of the coated sample developed with 40:60 Cu:TiC % V/V, 300 MPa compact pressure and peak current of 3 amp and pulse duration of 100 μ s.	36

List of tables

Table No.	Description	Page No
Table 1	Powder compaction, Proportions and Press capacity	22
Table 2	Experimental condition of EDC process	26
Table 3	Table for the hardness of Cu:TiC coated on mild steel	29
Table4	Table for the surface roughness of prepared sample	30

ABSTRACT

It is well known that Electro discharge machining (EDM) is a protruding non-conventional machining process for machining hard material. A very common perspective of EDM is surface modification which is done by the use of powder metallurgy green compact and sintered electrode as tool material which makes a hard and wear resistant layer on the workpiece during electrical discharge. The process is done with the reversal of polarity and is known as electro-discharge coating (EDC). Here we have used Titanium Carbide (TiC) and Copper (Cu) as coating material. Effect of various process parameters in EDM and powder metallurgy compaction process such as current, compaction pressure, composition of powder mixture on material transfer rate and tool wear rate have been investigated. The hardness of the coating was analyzed by Vickers Micro hardness Tester. Surface roughness values of the coatings were measured and also the analysis of compounds present in the coating was done by XRD (X-Ray Diffraction) technique.

CHAPTER 1

INTRODUCTION ABOUT THE PROJECT

Electro-discharge machining (EDM) is a spark erosion machining process in which the metal removal takes place due to erosion caused by the electric spark. It is broadly used for machining intricate contours in any material, irrespective of its hardness, which is an electrical conductor where conventional machining cannot be used. There are two foremost drawbacks of die-sinking EDM process; one is the development of brittle and fractured white layer on the surface over which machining is done and the other is tool wear which is generally carbide formed by the reaction between worn out electrode elements and carbon from dielectric material. The process by which a white carbide layer is formed on the workpiece on reversing the polarity improves several properties of workpiece is known as electro-discharge coating (EDC). It leads to improvement in hardness and abrasive wear resistance of the original material. The basic properties of EDC electrode material must have such as electrical and thermal conductivity, a high melting temperature, lower wear rate, and resistance to distortion during machining. Powder metallurgy compact, either green or semi-sintered, can play a dynamic role as EDM tool, which can supply essential materials to the surface of the workpiece. The feeble holding around the powder particles helps in this respect. Alternate preferences of P/M tools lie in the realities that they might be manufactured effortlessly by blending powders of any ratio and could be given different shapes with less exertion. At particular spot, a heat affected zone is created on the workpiece surface, in the upper region a recast layer of solidified melt material components from the instrument, workpiece and dielectric liquid. This could be impressively harder than the mass material or can have preferable surface roughness qualities over the first workpiece relying upon the metallurgy. Harder layers might be valuable in giving expanded scraped spot and erosion safety.

EDC is a coating technique in which tool electrode manufactured by powder metallurgy technique (powder compaction in power press at certain pressures) used as anode and work-piece (on which coating is to be done) is selected as cathode in EDM (polarity opposite to the electrical discharge machining) and in the presence of dielectric fluid, material is decomposed from the tool electrode and deposited over the work-piece surface. Among these coating processes EDC has some specific advantages which make an emerging coating technology. In this method of

coating, there is no need of vacuum chamber or any special apparatus. Using simple EDM set-up and by selecting appropriate parameters coating of different materials can be done on different substrate materials.

Electro-discharge machining (EDM) is a well-recognized nonconventional machining process. In the year 1770, Electrical discharge machining was started when the discovery of erosive effect of electric discharges was done by English scientist Joseph Priestly. In 1930, efforts were made for the first period to machine diamonds and metals with electrical discharges. Erosion was important and mainly caused by erratic arc discharges occurring in air between workpiece and the tool electrode linked to a DC power source. The overheating of the machining area made the processes as not very precise and these processes may be defined as “arc machining” rather than “spark machining”. However, it was the year 1980 which brought the beginning of Computer Numerical Control (CNC) in EDM due to which the efficiency of the machining operation was improved in tremendous manner. It is greatly used for machining intricate contours of hard materials where traditional machining cannot be used. It is a well-known practice in die and mold-making trades for fairly a few years. During the process of electrical discharge machining (EDM), the surface of the workpiece undergoes melting and vaporization by high voltages electric discharges tailed by fast cooling by the dielectric. The dielectric provides the insulating effect which quite is useful in evading electrolysis of the electrodes throughout the EDM process. Spark is started at the point of lowest inter-electrode gap by a high voltage, disabling the dielectric breakdown strength of that gap. This yields a typical heat-affected zone (HAZ).

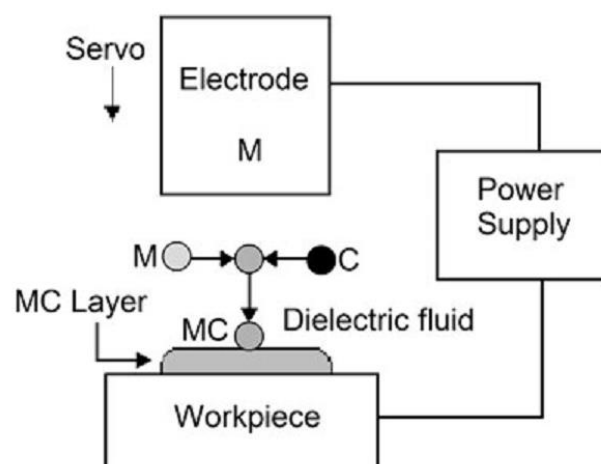

Fig1: Schematic diagram of EDC

P/M compact which can be either green or semi-sintered, usually plays a crucial role as EDM tool, which can be used to deposit required materials to the surface of workpiece. The weak bonding among the particles of powder helps in this respect. The properties of P/M tools can be organized by varying compaction pressure, temperature of sintering and also the composition of the constituents. The P/M electrodes were more delicate to variations in pulse current and pulse duration and their influence on output constraints such as material removal rate and electrode wear was found to be dissimilar as equaled to traditional electrodes. The P/M tools modify the surface reliability of a work surface. By varying compaction pressure and sintering temperature the properties of P/M tools can be controlled. The P/M tool electrodes are preferred because they allow higher discharge energies which can be used with suspended powder particles, thereby creating denser re-form layers and increased vulnerability to micro-cracking.

CHAPTER-2

LITERATURE SURVEY

Authors (year)	Title	Coating Material	Substrate Material	Experimental Parameters	Major Findings
P.K. Philip, A Gangadhar et al. (1994)	Improvement of wear resistance by EDM with tungsten carbide P/M Electrode.	Powder compact of 10 mm dia and 20 mm length containing 40% WC and 60% Fe.	Mild Steel pin of 10 mm. dia and 20 mm. length	Feed= 0.148 mm /rev, depth of cut= 2 mm, Current = 9 A, frequency = 20 kHz, Current = 18 A; frequency = 20 kHz.	WC-covered HSS devices show enhanced wear safety even under the great weight and temperature conditions experienced in metal cutting. 25%-60% change in grating wear safety and 20%-half decrease in cutting strengths are watched with WC-covered HSS apparatuses.
Z.L. Wang et al. (2002)	Surface modification by EDM with a Ti powder green compact electrode .	Green compacted electrode of TiC	Metal steel	Dia. Of powder= 80 microns, Electrode size= 12 sq.mm, Discharge current= 2.2-10 amp., Discharge duration= 2-12 microsecs., Duty factor= 5.88%, M/Cing time= 18 min., M/Cing area= 12 sq.mm, Electrode dia.= 12 mm., Pulse interval time= 64 mscs.	Hardness of base metal is expanded to 2000 HV from 332HV. The methodology of EDC is exceptionally straightforward and does not require any extraordinary supplies. The surface is exceptionally rich in covering material and sum diminishes towards the base material.
S.K. Ho , D.K. Aspinwall, W. Voice. (2007)	Use of powder metallurgy (PM) compacted electrodes for electrical discharge surface	Powder metallurgy tool electrode(TiC, WC, Ni etc. with Cobalt as the binder)	Ti-6Al-4V	Particle size= 1-175 microns, Compaction pressure= 100-540 Mpas, Sintering temp.= 900-1300 degreecent., W/P size= 18mm.*14mm*10mm., OCV= 270 volts, Peak current= 0.1-2.9 amp. In 0.1 amp. Steps,Pulse on	Significant expand in workpiece microhardness was measured up to 1100hk0.025, presumably because of the structuring of Tio2.

	alloying/modification of Ti-6Al-4V alloy			time= 100 mscs., Pulse off time= 25 mscs., Both polarities were used	
S. Wald, G.Appelbaum et al. (1999)	Hard coatings of metals and ceramics with a new electro-thermal-chemical gun technology	WC-Co and Cr3C2-NiCr	Stainless steel discs (SS304), 5 mm thick, 60 mm diameter were used as substrates.	Pulse width -150 μ s, Pulse energy 1-several kJ, Plasma temperature - 30000°C, Plasma pressure -1000 bar, Plasma velocity -7000 m/s.	The system empowers the shaping of astounding coatings at high through put in a flexible o€-line programmable way.
H.G. Lee a , J. Simao , D.K. Aspinwall et al. (2003)	Workpiece surface modification using electrical discharge machining	WC/Co	2% Cr steel mill roll material textured/all oayed	Open circuit voltage(V)= 200, Duty factor (%)=50 (i.e. pulse on-time = pulse off-time). Variable parameters Levels (A) Wire material Nickel Copper. (B) Electrode polarity Positive Negative. (C) Peak current (A)= 8 -12 (D) Capacitance (μ F)=0.11 (E) Pulse on-time (μ s)=3.2-6.4.	Comparable roll surface geographies were handled with incompletely sintered WC/Co and "traditional" copper and graphite instrument terminals. A significantly harder alloyed layer on the EDT roll surface (in excess of 900 Hk0. 025) was accomplished when utilizing somewhat sintered WC/Co anodes, as contrasted with EDT move surfaces textured with traditional electrodes(500–740 Hk0. 025).
Toshio Moro et al. (2004)	Study on the surface modification system with electrical discharge machine in the practical usage	TiC semi-sintered electrode	Steel (S45C)	Electrode Area= 10 sq.mm, Discharge current= 8 amp., Discharge duration= 8 microscs., Pulse interval time= 128 mscs., Duty factor= 5.9%, DCSP, M/Cing area= 100 sq.mm., M/Cing time= 960 scs., Powder particle size= 1 microns	The instrument treated by semi-sintered Tic terminal is enhanced in examination to Tin .Comparison of covering hardness of Tic and Tin were carried out.
Katsushi	Surface	Ti or W	AISI-1049	Powder= Ti(<36 microns),	

Furutani et al. (1999)	modification by EDM by Ti powder in working fluid.			Dielectric= Oil(EDF-K by Mitsubishi), Electrode= dia. 1mm., Density= 50 gm/ltr, Polarity= Both, Peak current=1-20 amp., Pulse duration= 2-2046, Duty factor= 0.04-50%, Gap voltage= 80-320 volts.	Hardness is expanded from 400 to 1600hv. Growth of Tic layer by the powder suspension or pivoting cathode of copper.
Sanjeev Kumar et al. (2012)	Surface modification of die steel materials by EDM method using tungsten powder-mixed dielectric	Ti (Cu electrode)	OHNS die steel,D2 die steel,H13 die steel	Sparking Voltage= 135(+5%,-5%) Peak current= 2,4,6 amp. Pulse on time= 5,10,20 microscs. Pulse off time= 38,57,85 microscs. Servo control= Electro-mechanical, DCSP, Commercial grade kerosene, Machining time= 10 min. for each cut, Powder concentration= 15 gm/ltr	Hardness increments:- OHNS pass on steel= 106.3% , D2 die steel= 116.2% , H13 die steel= 130.5% .Optimum machining parameters are overall situated and the impact of the peah current,pulse on time ,beat off time are generally guaranteeing.
Pichai Janman ee et al. (2012)	Surface modification of tungsten carbide by electrical discharge coating (EDC) using a titanium powder suspension	TiC (Cu electrode)	WC90-Co10	Particle size= 36 microns,Pulse on time= 510 microscs., OCV= 150 volts, Working time= 2 scs., Jump time= 0.5 scs., M/Cing time= 15,30,60 min. ,current= 10,15,20,25 amp., Duty factor= 20,40,50,80.%, Rotating electrode= 100 rpm, circulation of fluid= 12 ltrs/min., Powder concentration= 50 gms/ltrs.	The surface of coating holds less splits and its surface hardness expanded from 990 HV to 1750 HV, which is near the hardness of titanium carbide. Microcrack diminishment and hardness increment with the measure of blended titanium covering layer, which comes about because of the dissemination of particles.
Corinna Graf et al. (2007)	Preparation and characterization of doped metal-	Pure TiO ₂ , TiO ₂ /4 wt.% Ce, TiO ₂ /4 wt.% Gd	Pure titanium substrates were used (1.2mm	A voltage of 180V and a current of 10A (maximum) were taken. Concentration of dopand in electrolyte (mmol/l):	The unadulterated SOLECTRO Tio2- layers comprise of a filigree and coral-like structure. Expansion of dopands has

	supported TiO ₂ -layers		thickness, dimension 1 cm×1 cm) as anode.	TiO ₂ /4 wt.% Ce-2.5, TiO ₂ /4 wt.% Gd-2.5. Annealing temperature (°C) TiO ₂ – – 400, 550, 750, 950. TiO ₂ /4 wt.% Ce -400, 550, 750, 950. TiO ₂ /4 wt.% Gd -400, 550.	no noteworthy impact of surface morphology. On the off chance that the layers were ready under the similar settings then the morphology is not affected by the dopant components and their fixations.
--	------------------------------------	--	---	--	---

CHAPTER-3

OBJECTIVES OF THE PRESENT WORK

1. To develop a hard and wear resistant TiC-Cu coating on mild steel substrate by electro discharge coating process using a tool electrode prepared with Ti and Cu powder and determine the material transfer rate (MTR), tool wear rate and surface roughness on variation of peak current (I_p) and T_{on} .
2. To study the composition of the layers in the coating being analyzed by X-ray diffraction (XRD) technique and also measured the hardness of coating by Vickers Micro-hardness test and effect of different parameters on hardness value of the coating.

SCHEDULE OF THE WORK

JULY	AUG	SEP	OCT	NOV	DEC	JAN	FEB	MARCH	APRIL	MAY	TASK
											literature survey
											objective determination
											material selection
											material purchase
											experimental planning and tool preparation
											EDC
											analysis
											writing thesis

CHAPTER-4

METHODOLOGY ADOPTED

The whole process can be divided in two parts:

4.1. Green compact sintered powder metallurgy (P/M) tool preparation

4.2. Electro Discharge coating (EDC) with P/M tool on mild steel substrate using EDM

In the first part, the titanium powder is to be first mixed with Copper powder in a blender and then it is cold compacted into disks using a press and a die so at the time of deposition tool material easily parted from the tool electrode and deposited over the work surface. A power press with a maximum load of 15 tons was used in the process. The sintering of green dense disks was supported in a furnace shielded with Ar gas atmosphere at 900 °C. The tool extension is manufactured by machining and the sintered specimens are joined as tips to the mild steel rods by the conductive material and used as electrodes in EDM.

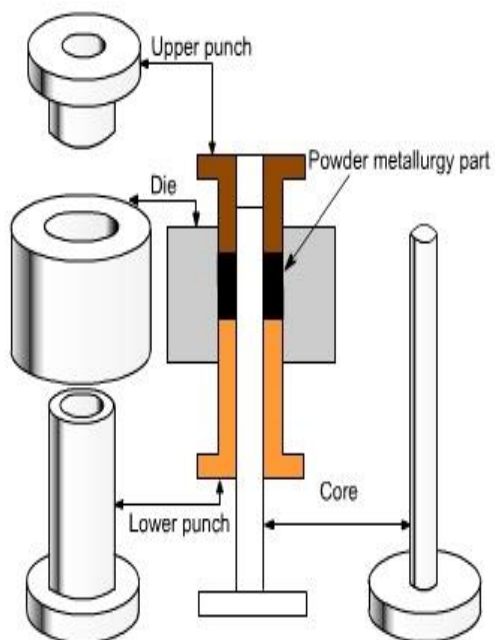

Fig 4.1: schematic diagram and typical setup of powder metallurgy power press

In the second step, with the use of EDM machine tool, hydrocarbon as dielectric oil, tool (anode) manufactured by the powder metallurgy method described above and using reverse polarity a kind of hard and wear resistant, TiC+Cu coating is created over the mild steel substrate by the chemical reaction between worn electrode material and carbon elements from dielectric fluid.



Fig4.2: Sintering Setup

After this part, the analysis part comes which is to be done by XRD technique. The X-Ray diffraction technique is used to find composition over the substrate surface.

CHAPTER-5

EXPERIMENTAL PLANNING AND PROCEDURES

5.1 Selection of tool material

For this test Tic+cu has been chosen as the tool electrode material. The reasons of selecting the Tic as tip material of the tool in light of the fact that these mixes is utilized broadly as a coating material for modification of surface for its characteristics like high abrasion resistance, high hardness, low coefficient of friction and high melting point. As the dielectric liquid likewise holds carbon, so it additionally comes in the coating layer expanding the rate of Tic which further enhances surface hardness of the coated layer, diminish the surface unpleasantness of the coated layer, diminish the shaping of microcracks and enhances the security of electric discharge and covering pace. The purposes behind blending the copper as an apparatus material are as takes after:

- 1 .High electrical conductivity
- 2 .Abundantly high liquefying point
3. Effectively accessible in the business
4. Binding reason

5.2 Selection of work piece material

For this test Aisi1020 mild steel has been chosen as a work piece material due to taking after reasons:

1. Widely utilized as a part of commercial ventures
2. Easily accessible

5.3 Selection of process parameters:

Discharge Voltage: In EDM, the discharge voltage is related to the spark gap and dielectric's breakdown strength. The open gap voltage increases before current can flow, until the ionization path is created through the dielectric fluid. Once the flow of current is started, voltage drops and stabilizes at the spark gap level. The width of the spark gap between the bottom edge of the electrode and workpiece is determined by the preset voltage. As voltage increases, the spark gap also increases due to which the flushing conditions get improved and also helps in stabilizing the cut. By increasing open circuit voltage, MRR, tool wear rate (TWR) and surface roughness increases because of increase in electric field strength.

Peak Current: The surface area of the cut governs the maximum amount of amperage. In roughing actions and in openings with large surface areas, higher amperage is used. Higher currents will enhance MRR, yet at the expense of surface finish and tool electrode wear. This is all more significant in EDM on the grounds that the machined depression will be a replica of tool electrode terminal and unnecessary wear will hamper the correctness of machining.

Pulse Duration and Pulse Interval: Each cycle has an on-time and off-time that is communicated in units of microseconds. Since all the work is carried out throughout on-time, the term of these pulses and the number of cycles for every second (frequency) will be paramount. Metal removal will be straight forwardly relative to the measure of energy expended throughout the on-time. The peak amperage and the length of the on-time control this energy. Pulse on-time will be normally alluded to as pulse duration and pulse off-time is called pulse interval.

Electrode Gap voltage: The most significant prerequisites for great execution will be gap stability and the response speed of the system; the vicinity of backlash will be especially undesirable.

Duty Factor: Duty factor is the rate of the pulse duration relative to the complete cycle time. For the most part, higher duty factor expanded cutting productivity.

5.4 Preparation of tool electrode:

The tool electrode is manufactured with the extension part material as mild steel and the pellet as of TiC and Cu mixed in three different composition. The tool extension part is basically created by the turning and facing process on a lathe machine in which its diameter is reduced from 15.6 mm to 10 mm. Total four number of tool extension as shown in fig.5.3 are produced upon which further joining of pellets are done. This joining is achieved by a conductive adhesive which is applied in between the pellets and tool thoroughly. Then araldite is also applied side by side along the circumference of pellet for strong joining. Tool is manufactured by Cu+TiC in the ratio of 40:60, 30:70 and 20:80 % by volume.

Table 1: Powder compaction, Proportions and Press capacity

Press capacity	15- 25 tons
Applied load	5.3 tons (depends on dimensions of compact)
Holding / Stand- up time	2 hr
Proportions of powders (Cu:TiC)	40:60, 30:70 and 20:80 % by Volume.
Compaction pressures	300 Mpa
Sintering Temperature	900°C



Fig5.1: Front view of compacted tool



Fig5.2: Top view of compacted tool

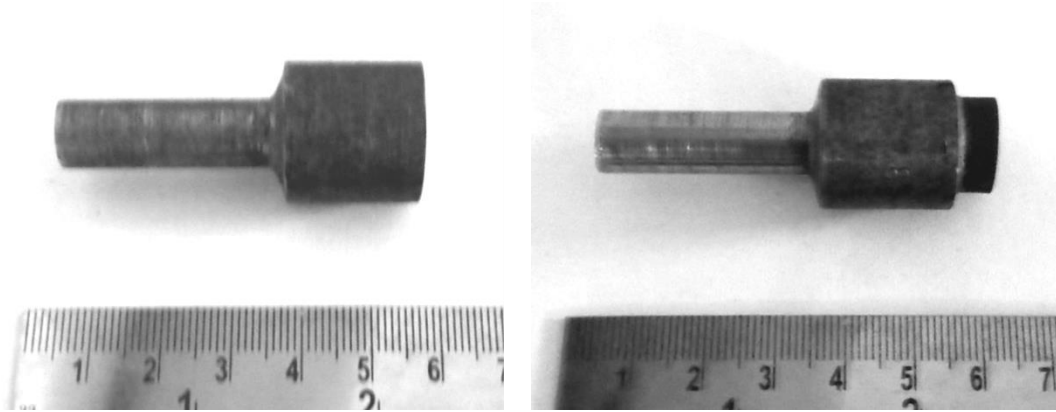

Fig5.3: Tool electrode extension before and after joined with powder compressed pellet

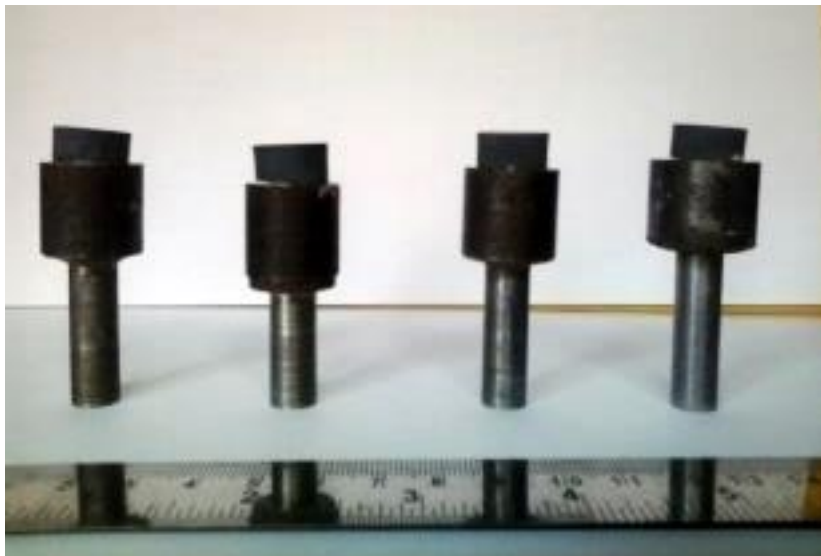

Fig 5.4: Tool Electrode

5.5 Work-pieces preparation

Work-pieces for coating are prepared from mild steel material. The mild steel plate of thickness 5 mm is first cut into several pieces using band-saw cutting machine. Then surface grinding was done removing rust and other coating material and polishing. Work- pieces of mild steel were cut into the 20x20x5 mm size.

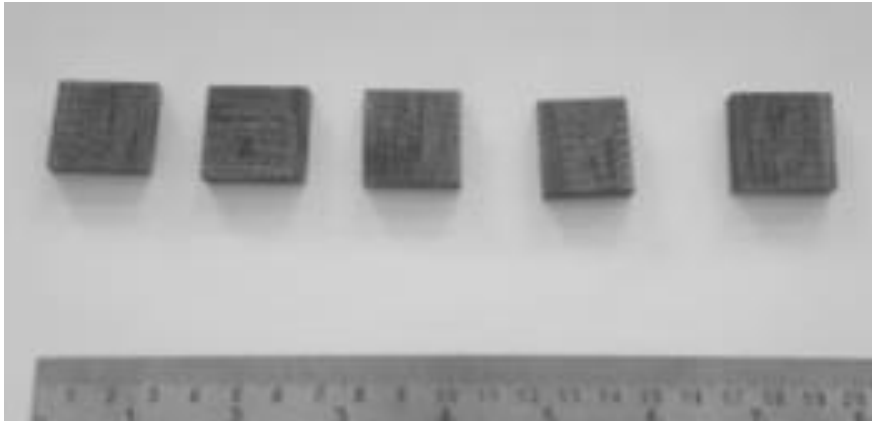

Fig 5.5: AISI 1020 mild steel workpieces prepared for coating

5.6 Electro Discharge coating (EDC) with P/M tool on mild steel by using EDM

In order to carry out the EDC of the work surface by erosion, transformer oil is used as dielectric. In general tool electrode is maintained as cathode for basic metal cutting process, but in this case, tool electrode was kept as anode (precisely condition is called reverse polarity). Heat affected zone comes while surface grinding and it is further evacuated with fine surface grinding. The entire investigation was carried out by Electric Discharge Machine, (Fig.5.6) model ELECTRONICA- ELECTRAPULS with servo-head and negative polarity for terminal was utilized to direct the tests. The dielectric liquid was utilized as Commercial grade EDM oil. Trials were led with negative polarity of cathode. The pulsed release current was connected in different steps in negative mode. Working rule: In EDC, the transformation of electrical energy into thermal energy happens through an arrangement of discrete electrical releases happening between the anode and workpiece submerged in a dielectric liquid.

The EDM comprises of taking after real parts as:

1. Dielectric supply, pump and circulation system.
2. Power producer and control division.
3. Functioning tank with work holding gadget.
4. X-Y table obliging the working table.
5. The servo framework to bolster the tool.



Fig 5.6: Experimental Setup for EDC

5.7 Experimental Procedures:

The parameters composed beneath are normal for all test setups. The weight of the apparatuses and work- pieces have been taken by electronic weighing machine and the weights taken are right up to the three decimal spots. The weight of the work-piece and tool prior and then afterward the coating measured and the measure of deposition has been figured. Fig.6.1 shows the coated surface at various current and surface coated by Tic and Cu blended powder compacted tool.

Fixed EDM parameters:

Voltage- 40 V, Duty Factor - 50%, Polarity – Negative,

Time of experimentation -10 min, No flushing,

Tool powder ratio= Cu: TiC , Work Piece = Mild steel

5.8 Experimental condition of EDC process:**Table 2: Experimental condition of EDC process**

Exp. No.	Sample No.	Tool Powder ratio (Cu:TiC)	Peak Current, I_p (Amp)	T_{on} (μ s)
1	1	40:60	1	100
2	2	40:60	2	100
3	3	40:60	3	100
4	4	40:60	4	100
5	5	40:60	5	100
6	9	40:60	6	100
7	11	40:60	5	200
8	12	40:60	5	300
9	6	30:70	1	100
10	7	30:70	2	100
11	8	30:70	3	100

CHAPTER-6

Results and discussion:

As we have manufactured pellets of three different composition of Cu+TiC by % V/V which were 20:80, 30:70, 40:60. This 20:80 ratio pellet did not work due to high brittleness and low conductivity. So we have performed the experiments only with 30:70 and 40:60 ratio pellets to study the effect of different parameters.

6.1 Experimental Details:

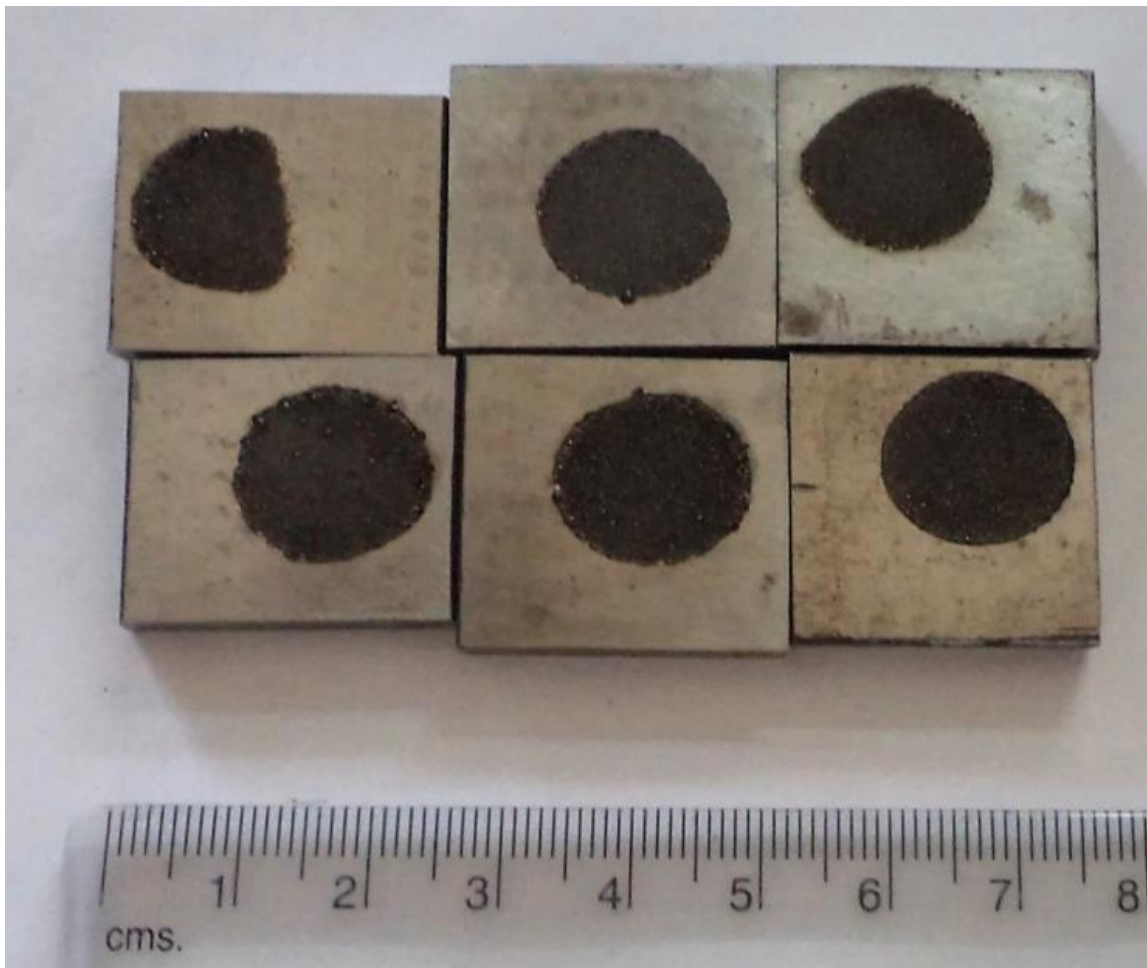

Fig6.1: AISI mild steel coated with TiC-Cu

6.2 Micro-hardness Test : Hardness testing machines provide the humblest and most inexpensive testing techniques which plays an important role in investigation activities, manufacturing activities, and commercial trades.

In the Vickers hardness test, diamond pyramid indenter with a 136° plot between inverse confronts is pressed into the sample under a test power F (kgf). The hardness number (HV) is acquired by dividing F by the area, A (mm^2), of contact between the indenter and sample. This zone is computed from the inclining length, d (mm), of the indentation when the indenter is evacuated.

The Vickers hardness test is the greatest flexible hardness testing strategy for those that utilize distinctive load settings. The Micro-Vickers hardness test, which acknowledges load settings of 1kgf (9.807n) or less, is particularly appropriate for modern handling today, where exactness prerequisites are expanding because of innovation enhancements. Vickers hardness testing at loads of 1 kilogram and up is otherwise called overwhelming load Vickers or Macro Vickers. The other testing factors are like nimbler load vickers testing. This sort of testing may be utilized to meet the necessities of universal determinations or to swap Rockwell testing.



Fig6.2: Micro-Hardness Tester

The thickness of coating of 30:70 %V/V composition (Cu+TiC) and also that of 40:60 %V/V when the currents are low (1Amp,2Amp) was very less and not uniform , so we have checked the hardness, surface roughness and XRD analysis only on the remaining experiments in which thickness and uniformity was sufficient.

Table 3: Table for the hardness of Cu:TiC coated on mild steel

Test load=500gf

Dwell Time= 10sec

Exp. No	3	4	5	6	7	8
Hardness values	1248.6	1306.5	2255.5	2116.6	2303.1	2250.0
	1414.8	1305.5	2257.8	1407.1	1714.5	2738.7
	2386.7	1344.1	2447.4	2333.1	2150.4	2301.9
	1337.9	2560.3	1426.5	2000.3	1962.7	2314.2
	1565.1	2005.8	2031.8	2813.1	2254.4	2428.4
	1482.3	2443.1	1920.6	2774.6	2720.8	1928.1
	1440.6	1917.4	1457.2	1717.7	1898.4	2746.1
	1408.7	2126.7	1770.4	2988.2	1891.5	2250.0
Avg. Hardness	1535.58	1876.17	1945.9	2268.83	2143.47	2396.85

6.3 Surface Roughness of mild steel coated with Cu+TiC:

Table4: Table for the surface roughness of prepared sample

Exp No.(Composition)	Surface Roughness	R _a (Average surface roughness) (μm)
3(40:60)	6.036	6.640
	6.566	
	7.326	
4(40:60)	4.022	5.035
	6.024	
	5.061	
5(40:60)	7.703	7.371
	7.490	
	6.920	
6(40:60)	7.136	7.596
	8.486	
	7.163	
7(40:60)	9.758	9.210
	9.014	
	8.875	
8(40:60)	9.390	9.310
	10.054	
	8.506	

6.4 Effect of different parameters on deposition rate

6.4.1 Effect of peak current (I_p)

The effect of I_p on deposition rate is studied for various current of 1 to 6A by keeping T_{on} constant as 100 μs. It is studied under the conditions of different pulse durations, 40v gap voltage, TiC+Cu as the tool electrode material with negative polarity and mild steel as the material of workpiece.

The effect of peak current on deposition rate is shown in fig6.3 for pulse duration of 100μs. At this value of 100μs, the deposition rate increases with the intensity of discharge

current up to 3A and then starts decreasing as the machining is done on high current. It is observed that as peak current rises from the low peak value to high, the deposition rate increases by heating of the workpiece. At high currents, the low deposition rate is considered to be related to inferior discharge because of inadequate cooling of the workpiece and there is also the chance of partial machining with the increase of current.

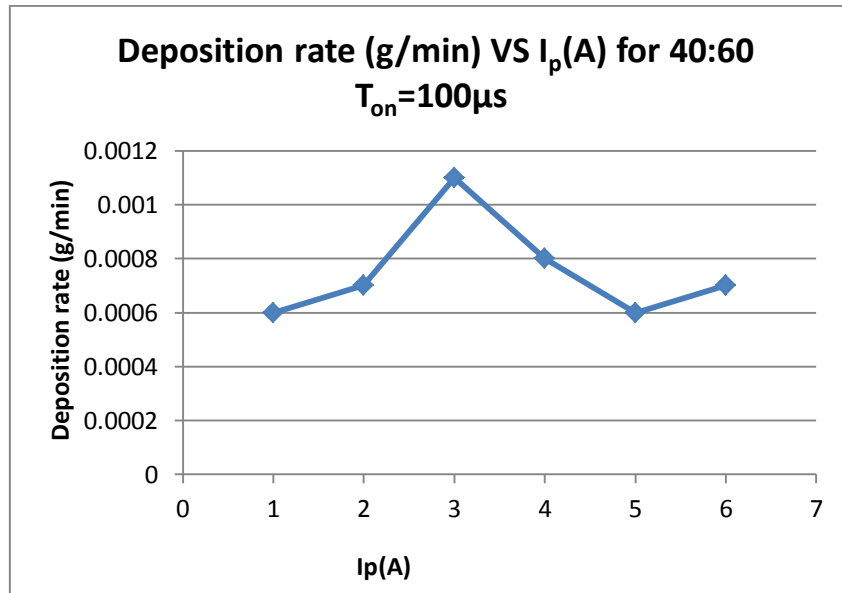

Fig6.3: Effect of peak current on deposition rate

6.4.2 Effect of pulse on time (Ton)

The experiment has been directed at 100µs, 200 µs and 300µs because at the higher value of Ton, more energy provided for machining which can lead unnecessary heating of machining zone due to which arcing may occur and at the lower value of the Ton, less energy is provided for machining which may lead extra time taken for machining.

The effect of pulse on time is studied by varying it from 100 to 300 µs for a constant current of 5A. It is understood that increasing pulse duration from 100µs to 200µs workpiece deposition rate increases because of the principal effect of input energy. At higher Ton spark is produced for long duration so more material is deposited. But when Ton is further increased to 300 µs the deposition rate decreases. This may be due to the less bonding between TiC particles which led them to remove from the electrode tip in bulk amount and which cannot get adhered to the surface of workpiece.

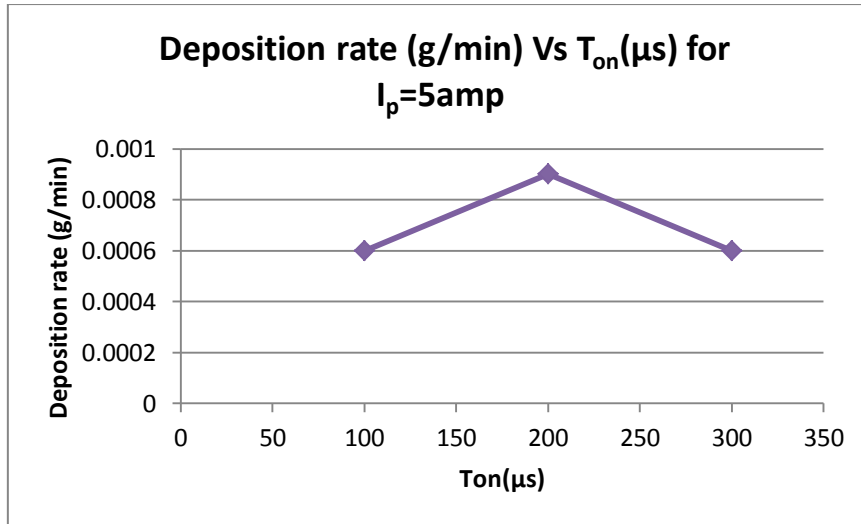

Fig6.4: Effect of T_{on} on deposition rate

6.5 Effect of different parameters on tool wear rate

6.5.1 Effect of peak current (I_p)

As the peak current increases from 1Amp to 6Amp the tool wear rate gradually increases while keeping the pulse duration constant as 100 μ s.

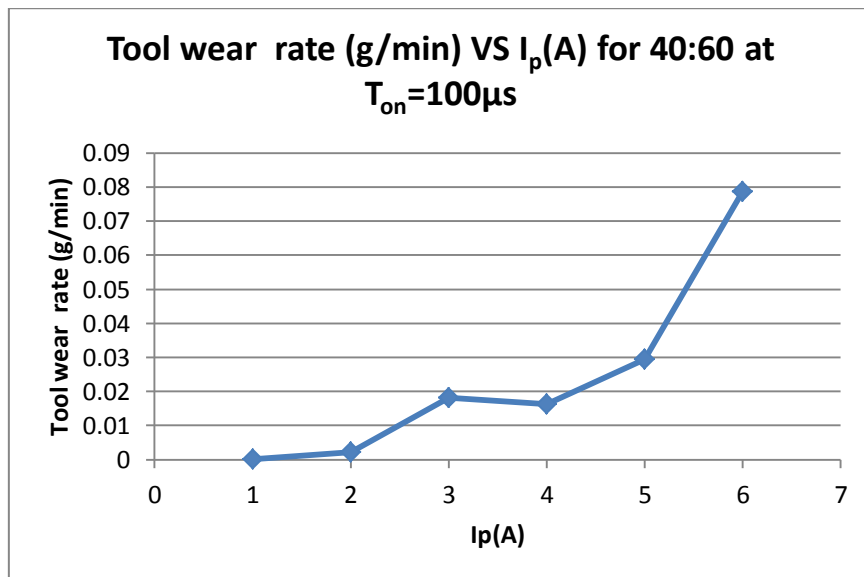

Fig6.5: Effect of peak current on tool wear rate

6.5.2 Effect of pulse on time (T_{on})

As the pulse on time increases from $100\mu s$ to $300\mu s$, the tool wear rate also increases. This is due to the fact that at long pulse duration more energy is released at the electrode gap which causes to remove more material from the tool electrode tip.

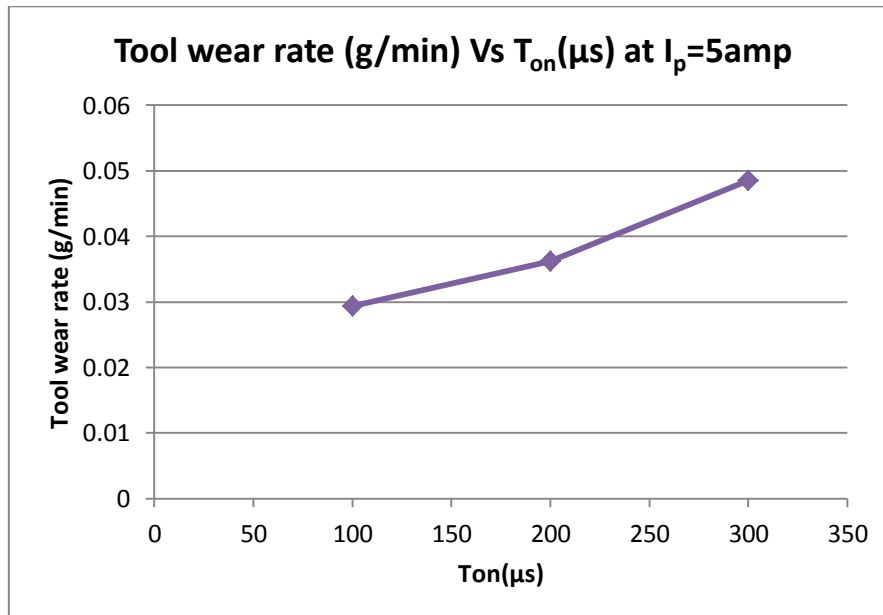

Fig6.6: Effect of T_{on} on tool wear rate

6.6: Effect of different parameters on microhardness

6.6.1: Effect of peak current (I_p)

The effect of I_p on micro hardness is deliberated by varying I_p from 3 to 6 A at a T_{on} value of $100\mu s$. As the coating thickness is very low at the peak currents of 1A and 2A so micro hardness test is started from 3A. From the graph plotted it is observed that the microharness increases as the peak current increases.. It is because at higher current the material may be strongly joined with the surafce of mild steel and thus the surafce layer of better strength is shaped on the surafce of workpiece. The effect of I_p on micro hardness is shown in Fig.6.7.

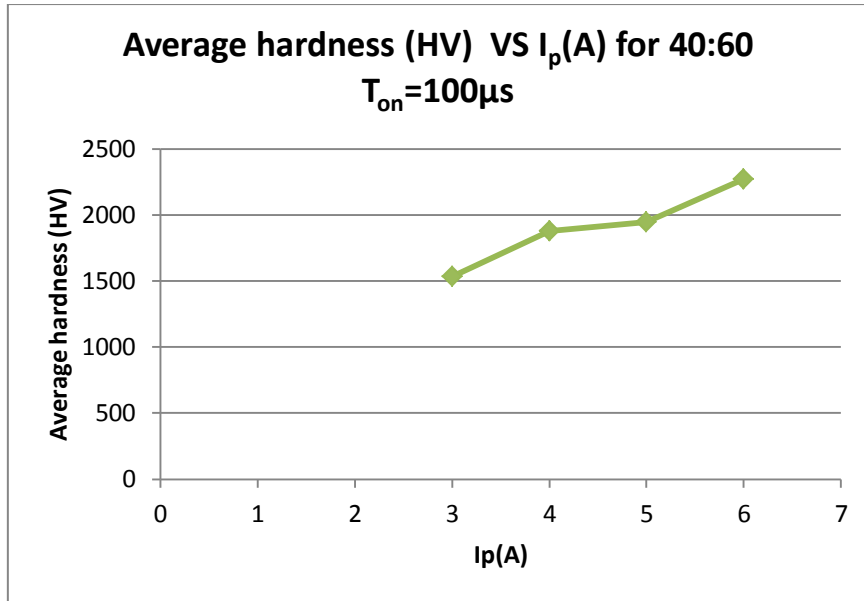

Fig6.7: Effect of peak current on microhardness

6.6.2 Effect of pulse on time (T_{on})

The effect of T_{on} is studied at constant current of 5A and T_{on} is varied by 100 to 300 μs . From the graph plotted it is understood that at longer pulse duration the microhardness of the surface coating on mild steel workpiece is very high. As at high pulse duration tool wear rate is more hence extra material may be resolutely surrounded to the mild steel surface at higher T_{on} . So at higher T_{on} surface layer strength is increased and hence micro hardness is also increased. The effect of T_{on} on microhardness is shown in fig.6.8.

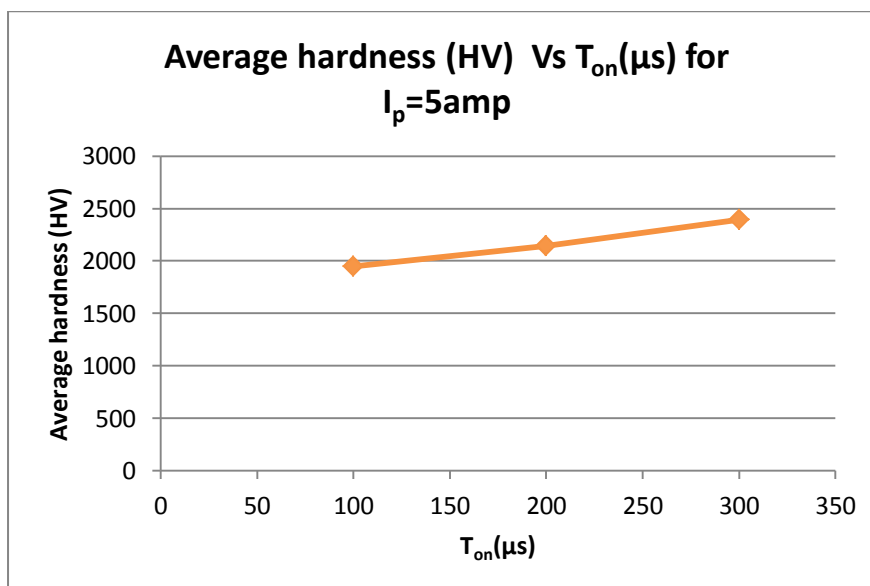

Fig6.8: Effect of T_{on} on microhardness

6.7 Effect of different parameters on Surface Roughness

Surface roughness is humbly mentioned as the measure of surface grains. The coating roughness can be find out by using a handy, Taly surf instrument. Measurement is done at various points of the coating surface so that well result can be attained. The average surface roughness (R_a) is calculated. The value of surface roughness is given in Table 5.

6.7.1 Effect of I_p on surface roughness

The effect of I_p on surface roughness is studied by varying current and keeping T_{on} as $100\mu s$. From the graph plotted it is observed that when current increases the average value of surface roughness also increases. The main cause for this growth is at higher value of current the material may be deposited in bulk and a rough surface is gained. Fig.6.8.1 shows the effect of I_p on surface roughness.

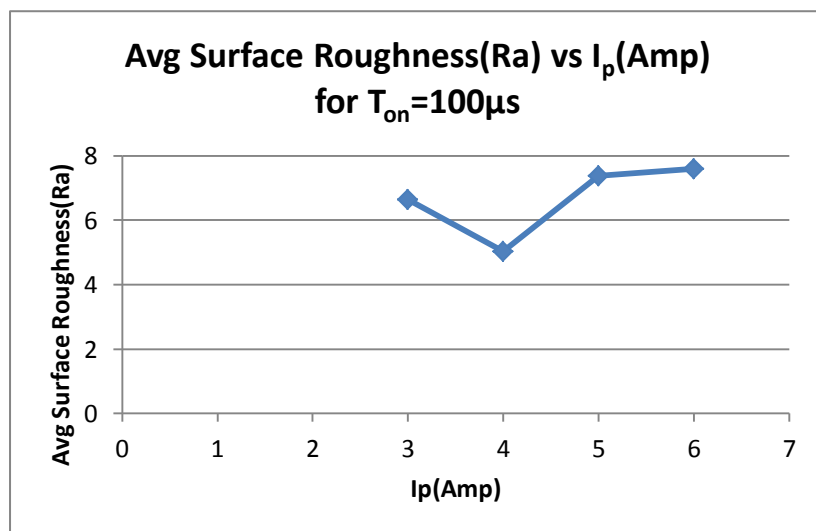

Fig6.9: Effect of peak current on surface roughness

6.7.2 Effect of pulse on time (T_{on})

As the pulse on time increases from $100\mu s$ to $300\mu s$ the average surface roughness increases gradually. It is understood that for lower value of pulse duration, surface finish of workpiece is smooth while it becomes rough as the pulse duration increases.

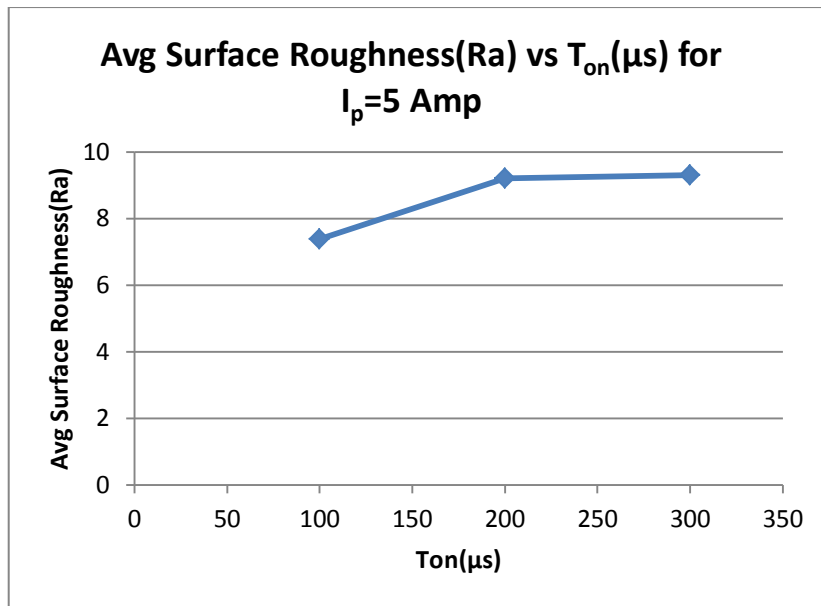

Fig7.0: Effect of T_{on} on surface roughness

6.8 XRD Analysis

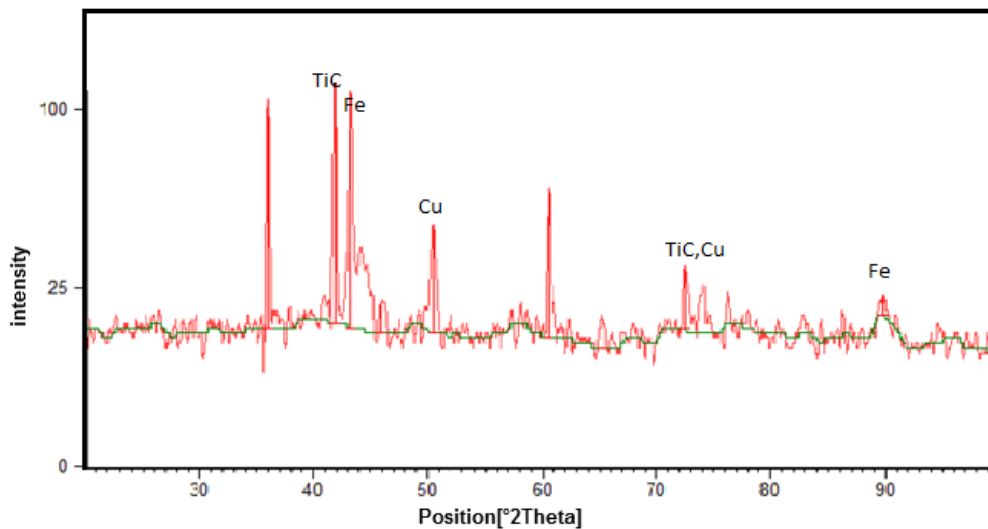

Fig7.1: XRD plot of the coated sample developed with 40:60 Cu:TiC %V/V, 300 MPa compact pressure and peak current of 3 amp and pulse duration of 100 μs .

X-Ray diffraction is utilized to discover components of structure over the workpiece surface. In this exploration work, coating when dissected by XRD gives above demonstrated chart, which indicates diffraction summit of TiC, Cu and Fe.

CHAPTER-7

Conclusions:

1. From the experiments, it is found that Cu+TiC is deposited successfully on mild steel surface by electro discharge coating process.
2. From the current experiments and their analysis, it has been found that the coating increases the hardness value from 1535.8 HV to 2268.83HV when the peak current is varied from 3Amp to 6Amp for pulse duration as 100 μ s.
3. This hardness value also rises from 1945.9HV to 2396.5HV when the pulse duration is varied from 100 μ s to 300 μ s and the peak current is kept constant as 5Amp.
4. The surface roughness of the mild steel workpiece is increased from 6.64 to 7.596 μ m as the current is increased from 3Amp to 6Amp keeping T_{on} as constant equal to 100 μ s.
5. As the pulse duration is varied from 100 μ s to 300 μ s keeping peak current as 5Amp, the change in surface roughness is more as it increases from 7.371 to 9.31 μ m when it is compared with the change in surface roughness on varying peak current and keeping T_{on} as constant.

REFERENCES:

1. Lee, H.G., Simao, J.,Aspinwall, D.K., Dewesa R.C., Voice W.,2004, “Electrical discharge surface alloying,” *Journal of Materials Processing Technology*, 149, pp. 334–340.
2. Patowari, P.K. , Saha P. and Mishra P.K., 2010, “Artificial Neural Network Model in Surface Modification by EDM Using Tungsten–Copper Powder Metallurgy Sintered Electrodes,” *Int J Adv Manuf Technol* , 51, pp. 627–638.
3. Erden A (1983) Effect of materials on the mechanism of electric discharge machining (E.D.M.). *Trans ASME J Eng Mater Technol* 105:132–138.
4. Tarng YS, Ma SC, Chung LK (1995) Determination of optimal cutting parameters in wire electrical discharge machining. *Int J Mach Tools Manuf* 35(12):1693–1701.
5. Promod Kumar Patowari & Partha Saha & P. K. Mishra(2010) Artificial neural network model in surface modification by EDM using tungsten–copper powder metallurgy sintered electrodes *Int J Adv Manuf Technol* 51:627–638.
6. Gangadhar, A., Shunmugan, M.S. and Philip, P.K. (1991) Surface modification in electro discharge processing with a powder compact tool electrode. *Journal of Friction Wear*, Vol. 143, pp. 45-55.
7. Kaplun, V.G., Kozlov, V.L, Nesmikh, V.S., Rukina, I.M. and Nosova, V.A. (1988) Study of tin-bronze coating wear resistance. *Soviet Journal of Friction Wear*, Vol. 9(1), pp. 130-133.
8. Furutani, K., Saneto, A., Takezawa, H., Mohri, N. and Miyake, H. (2001) Accretion of titanium carbide by electrical discharge machining with powder suspended in working fluid. *Journal of Precision Engineering*, Vol. 25, pp. 134-144.
9. Moro, T., Mohri, N., Otsubo, H., Goto, A. and Saito, N. (2004) Study of surface modification system with electrical discharge machine in the practical usage. *Journal of Material Processing Technology*, Vol. 149, pp. 65-70.
10. Simao, J.,Aspinwalla, D.,El-Menshawyb, F., Meadows K., 2002, “Surface alloying using PM composite electrode materials when electrical discharge texturing hardened AISI D2,” *Journal of Materials Processing Technology*, 127, pp.211-216.
11. Kumara S., Batra U.,2012, “Surface modification of die steel materials by EDM method using tungsten powder-mixed dielectric,” *Journal of Manufacturing Processes*, 14,pp.35-40.

12. Kumar, S., Singh R., Singh T.P., Sethi B.L., 2009, "Surface modification by electrical discharge machining," *Journal of Materials Processing Technology* 209, pp.3675–3687.
13. Shunmugam, M.S., Philip, P.K., Gangadhar, A., 1994, "Improvement of wear resistance by EDM with tungsten carbide P/M electrode," *Wear*,171, pp.1-5 .
14. Janmanee, P., Muttamara, A., 2012, "Surface modification of tungsten carbide by electrical discharge coating (EDC) using a titanium powder suspension," *Applied Surface Science*, 258, pp.7255-7265.