



Queensland University of Technology
Brisbane Australia

This is the author's version of a work that was submitted/accepted for publication in the following source:

Li, Zhengrong, Liu, Yuee, Walker, Rodney A., Hayward, Ross F., & Zhang, Jinglan (2009) Towards automatic power line detection for a UAV surveillance system using pulse coupled neural filter and an improved Hough transform. *Machine Vision and Applications*, 21(5), pp. 677-686.

This file was downloaded from: <http://eprints.qut.edu.au/29121/>

© Copyright 2009 Springer-Verlag

Notice: *Changes introduced as a result of publishing processes such as copy-editing and formatting may not be reflected in this document. For a definitive version of this work, please refer to the published source:*

<http://dx.doi.org/10.1007/s00138-009-0206-y>

Towards Automatic Power Line Detection for UAV Surveillance System Using Pulse Coupled Neural Filter and Hough Transform

Zhengrong Li • Yuee Liu • Rodney Walker • Ross Hayward • Jinglan Zhang

Abstract Spatial information captured from optical remote sensor on board unmanned aerial vehicles (UAVs) has great potential in automatic surveillance of electrical infrastructure. For an automatic vision based power line inspection system, detecting power lines from cluttered background is one of the most important and challenging tasks. In this paper, a novel method is proposed specifically for power line detection from aerial images. A pulse couple neural filter is developed to remove the background noise and generate edge map prior to Hough transform being employed to detect straight lines. An improved Hough transform is used by performing knowledge-based line clustering in Hough space to refine the detection results. The experiment on real image data captured from a UAV platform demonstrates that the proposed approach is effective for automatic power line detection.

Keywords Machine vision • Power line inspection system • Unmanned Aerial Vehicles (UAVs) • Hough Transform • Pulse coupled neural filter • knowledge-based system

1 Introduction

Surveillance and maintenance of electrical infrastructure is a critical issue for the reliability of electricity transmission. Inspection and management of vegetation around power

lines is a significant cost component of maintenance of the electrical infrastructure. For example, Ergon Energy, one of the top electricity companies in Australia, currently spends \$80 million a year inspecting and managing vegetation that encroaches on power line assets. Ineffective surveillance could lead to loss of reliability of electricity transmission and produce serious hazards (e.g. the power outages happened in Canada and USA in 2003) [1, 2]. Currently, most electricity companies use calendar-based ground patrol [3]. However, calendar-based inspection by linesman is labor-intensive, time consuming and expensive. It also results in some zones being inspected more frequently than needed and others not often enough.

Satellites and aerial vehicles can pass over more regularly and automatically than the ground patrol. Therefore, remote sensing data captured from satellite and airborne sensors has great potential in assisting power line corridor monitoring. Two critical limitations for using current satellite sensors are the unfavorable revisit time and lack of choices in optimum spatial and spectral resolutions [4]. Airborne platform is an alternative but the traditional piloted airborne platforms are limited by their high operational costs. Remote sensors mounted on *Unmanned Aerial Vehicles* (UAVs) have the potential to fill this gap, by providing a cheap and flexible way to gather spatial data from power line corridors which can meet the requirements

of spatial, spectral, and temporal resolutions. Overhead power line inspection in remote and rural areas is an ideal application for UAVs because of less population density and large distribution of power line network. UAVs can fly relatively close to the power line, providing a cheap and flexible way to gather spatial data in power line corridor. In order to achieve automatic power line surveillance and inspection using UAVs, power line extraction is required because (1) it is useful for guiding the UAVs flying along the line and automatically collecting data in power line corridor; (2) risk assessment of power lines and the adjacent trees is meaningful only when power lines can be recognized.

There has been very limited investigation involved in developing algorithms for automatic extraction of power lines from aerial images because power lines in traditional aerial images are too small to be detected due to the flight height and resolution of the camera. Although straight line detection is a common and well studied research area in machine vision, most of the existing algorithms take bottom-up approaches which just use the intensity of single pixels. However, the qualitative performance of these algorithms varies widely across application domains as our notion of what constitutes a line can vary from one application area to another. Due to the wide variation of line types encountered in the UAV images that are not of interest, we require a more top-down approach that takes advantage of our understanding of line in this application area.

In this research, we combine the bottom-up and top down approaches and propose a knowledge-based technique specifically for power line detection in aerial images. The proposed method is tested on real image data captured from a UAV platform in Queensland rural areas.

The remainder of the paper is structured as follows. Section 2 briefly introduces related work in power line extraction. In section 3, our proposed approaches are

described in detail. Section 4 present and discuss the experimental results and section 5 concludes our work.

2 Related works

Most energy companies use Geographic Information Systems (GIS) to record locations of their assets (e.g. power poles), from which power line information can be inferred. However, in general the accuracy of such information is only suitable as a general guide. For an automatic power line inspection system using machine vision, the major problem focuses on how to effectively extract power lines from complicated image backgrounds.

Automatic power line detection from aerial imagery is a rather challenging task, especially when the background is cluttered. There has been very limited investigation involved in developing algorithms for the automatic power line extraction due to the low resolution of traditional aerial images. Some work on the visual control of an Unmanned Aerial Vehicle (UAV) for power line inspection has been simulated using a laboratory test rig [5]. They proposed an automatic power line detection method based on Hough transform, but the approach was just a simulation of straight line detection and not evaluated in real image data. More recently, the Radon transform was used to extract line segments of the power lines, followed by a grouping method to link each segment, and a Kalman filter was finally applied to connect the segments into an entire line [6]. Although some properties of power lines in the aerial image were discussed, the algorithms in [6] just focus on straight line detection, image edges and other mistakable linear features which are similar to power lines were not considered.

3 The proposed method

The Hough transform is an effective tool for detecting straight lines in images, thus it is a natural choice for the task of automatic power line detection. In real applications of straight line detection, an edge detector is often used to remove irrelevant data and reduce the computational cost prior to the Hough transform being employed. However, the application of classic edge detectors to the aerial images has demonstrated that they are sensitive to image noises, due to complex and irregular ground coverage. In this paper, we take advantage of the characteristics of power lines in aerial image and propose a filter based on a simplified pulse coupled neural network (PCNN) model. This filter can simultaneously remove the background noise of power lines as well as generate edge maps. After that, an improved Hough transform is used by performing knowledge-based line clustering in Hough space to refine the detection results.

3.1 Characteristics of power lines

Based on our observation, power lines in aerial image have the following characteristics:

(1) A power line has uniform brightness and the color looks different from upward and downward view. Viewing from the ground power line is usually dark, whereas viewing from the sky power line is brighter than the background simply because it is made of specific metal and has larger light reflection.

(2) A power line approximates a straight line although power line sag often exists. Due to the limited coverage area of a single image, the widths of power lines in the image tend to be similar. In addition, the lengths of power lines in one image are similar and power line is usually the longest line as it crosses the entire image.

(3) Power lines are approximately parallel to each other. Due to the forward angle of imaging sensor and deviation

from centre, power lines in the image are not completely parallel. However, the intersection of two power lines usually occurs far out of range of the image due to the limited size of images, and the intersecting angle of two lines is usually very small. A simplified illustration is shown in Figure 1.

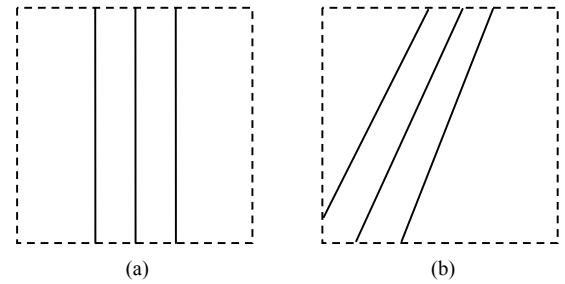

Figure 1 Power lines from different perspectives: (a) from the above view
(b) from the forward view and offset centre

3.2 Design of pulse coupled neural filter

Given that power lines are made of special metal, they have different solar reflectance compared to other background materials (e.g. grass, soil, and bitumen). This knowledge can be used for preliminary detection of power lines from aerial images. Using a filter to remove the irrelevant information will be helpful to reduce the false detection rate as well as the computational cost of line detection algorithm. Threshold filtering may be a practical solution. However, it is not robust because filtering by a threshold is sensitive to image noise and different thresholds may be required due to changing light conditions of the captured images. In this paper, a pulse coupled neural filter (PCNF) is developed for preliminary detection of power lines as well as edge maps generation.

Pulse-Coupled Neural Network (PCNN) is a relatively new biologically inspired approach based on the understanding of visual cortical models of small mammals [7]. Unlike other neural networks, the processing is automatic and there is no training involved in PCNN. The time

signatures generated from PCNN has the ability to extract edge information, texture information, and to segment the image. This type is very useful for image recognition engines.

3.1.1 Standard PCNN model

Most PCNNs are based on the Eckhorn model [8]. When applied to image processing, PCNN is a single layered, two-dimensional, laterally connected neural network of pulse coupled neurons. Each neuron corresponds to one pixel in an input image, receiving its corresponding pixel's color information (e.g. intensity) as an external stimulus. The neuron also connects with its neighboring neurons, receiving local stimuli from them. Thus, every neuron can be represented as a specific structure as shown in Figure 2.

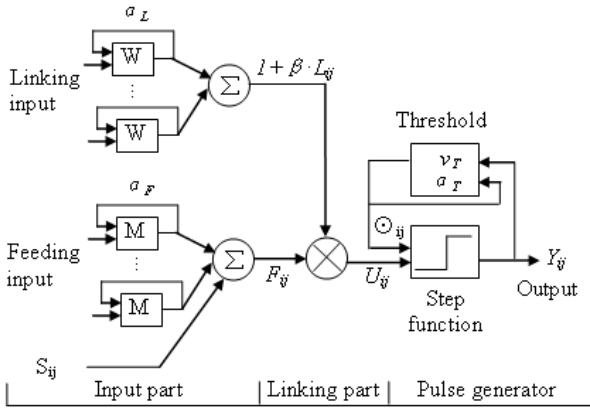

Figure 2 The structure of PCNN neuron [9]

The input part imports external and local inputs to the neuron by the feeding and linking part respectively. In the linking part, external and local stimuli are combined in an internal activation system, which accumulates the stimuli until it exceeds a dynamic threshold, and then the pulse generator produces a pulse output. Through iterative computation, PCNN neurons produce temporal series of pulse outputs. Similarities in the input pixels cause the associated neurons to pulse synchronously, thus indicating similar structures or textures. These temporal series of pulse

outputs contain information of input images and can be utilized for various image processing applications, such as image segmentation, edge detection, feature generation, noise reduction, etc. [10].

This standard PCNN model is usually described by the following 5 coupled equations:

$$F_{ij}(t) = S_{ij} + e^{-\alpha_F} \cdot F_{ij}(t-1) + V_F \cdot (M * Y(t-1))_{ij} \quad (1)$$

$$L_{ij}(t) = e^{-\alpha_L} \cdot L_{ij}(t-1) + V_L \cdot (W * Y(t-1))_{ij} \quad (2)$$

$$U_{ij}(t) = F_{ij}(t) \cdot (1 + \beta \cdot L_{ij}(t)) \quad (3)$$

$$Y_{ij}(t) = \begin{cases} 1 & U_{ij}(t) > \Theta_{ij}(t) \\ 0 & \text{Otherwise} \end{cases} \quad (4)$$

$$\Theta_{ij}(t) = e^{-\alpha_\Theta} \cdot \Theta_{ij}(t-1) + V_\Theta Y_{ij}(t-1) \quad (5)$$

Where, t is the iteration step, F_{ij} is the feeding input, L_{ij} is the linking input, S_{ij} is the intensity of pixel (i, j) , W and M are the weight matrices, $*$ is the convolution operator, Y is the output of neurons; U is the internal activity, β is the linking strength; Θ are the dynamic thresholds; α_F , α_L and α_Θ are the feeding, linking and threshold delay coefficients respectively; V_F , V_L and V_T are the feeding, linking and threshold magnitude scales respectively. The dynamic thresholds of all neurons are zero at $t < 1$.

3.1.2 A filter Based on Simplified PCNN

One of key problems of using PCNN is selecting the network parameters. The relationships of network parameters and its performance in image analysis is still not clear [7]. There are so many parameters in standard PCNN model that it is hard to select appropriate parameters for various image analysis tasks. In addition, classic PCNN model involves high computation cost because temporal dependence between iterations is explicitly used in the feeding, linking and

threshold updating components. In this paper, a simplified model is developed inheriting the characteristics of classic PCNN model and is described by equation 6-10:

$$F_{ij}(t) = \text{quantized_} I \quad (6)$$

$$L_{ij}(t) = \sum_{k,l \in K} W_{Lkl} \times Y_{kl}(t-1) \quad (7)$$

$$U_{ij}(t) = F_{ij}(t) + \beta \times L_{ij}(t) \quad (8)$$

$$Y_{ij}(t) = \begin{cases} 1 & U_{ij}(t) > \Theta_{ij}(t) \\ 0 & \text{other} \end{cases} \quad (9)$$

$$\Theta_{ij}(t) = \begin{cases} \Theta_{ij}(t-1) - \text{step} \\ V_T \times \Theta_{ij}(t) & \text{if } Y_{a_{ij}}(t-1) \neq 0 \end{cases} \quad (10)$$

The symbols in equations (6-10) represent the same meanings as in the standard PCNN model by equations (1-5).

We simplified the feeding input to be just external stimuli from image data and stimuli from neighboring neurons are not considered. This simplified model still keeps the characteristics of classic PCNN in that temporal dependence is implicitly included as the neuron outputs in the linking part come from the previous iteration. In this paper, original RGB images are transformed to HIS color space and the intensity component I is used as the feeding input. Moreover, the intensity component is uniformly quantized to 64 levels in order to reduce the intensity variation in image regions. This is helpful for filtering regions with similar intensities.

$1/\sqrt{2}$	1	$1/\sqrt{2}$
1	1	1
$1/\sqrt{2}$	1	$1/\sqrt{2}$

Figure 3 Linking weight matrix W_L

The linking input has also been simplified in that only 8 (i.e. 3×3 window) neighbors are adopted in the linking weight matrix W_L . Each element in W_L is the reciprocal of Euclidean distance between this element and the centre of

the window (Figure 3). In this case, neighboring neurons with the closer distance have greater impact on the central neuron. For the calculation of neuron internal status U , a new linear modulation of feeding and linking input is used to avoid zero-valued pixel's influence to the internal status of its neighboring pixels. The linking strength β in this research is set to be 0.2. The pulsed output of neuron Y is binary, and if the neuron pulsed $Y = 1$, otherwise $Y = 0$. Initially Y is set to be a zero-valued matrix. Whether a neuron can pulse or not depends on the comparison of its internal status U with the dynamic threshold Θ . The threshold Θ is initialized to be larger than the maximum value of external stimulus and gradually decays. The dynamic threshold Θ is changing during the iteration operation to control neuron pulse. If the neuron has been pulsed, a large threshold is given to this neuron by implying a magnitude scale V_T to make sure it will not pulse in a while. Otherwise the threshold of this neuron will be decayed by subtracting a step value step .

Given that power lines have higher light reflectance and are usually brighter than the background, they can be roughly detected from the temporal series of PCNN pulsed outputs. In the early stage of the iteration, neurons correspond to power lines pulsed because they have larger external stimulus than most of the background area. Figure 4 shows an aerial image contain power lines and 7 temporal pulse outputs in different iterations of PCNN. As is shown in Figure 4, in the first iteration of PCNN, no neuron pulses because of the high initial threshold. With the progress of PCNN iteration, neurons corresponding to power lines pulse earlier than other objects in the image. From the temporal outputs of PCNN, different objects of interest can be extracted because PCNN tends to group pixels with similar intensities and structures and also considers spatial relationships among neurons. The temporal information generated by PCNN is also useful for image segmentation

and image noise location, which is an advantage over other

filters.

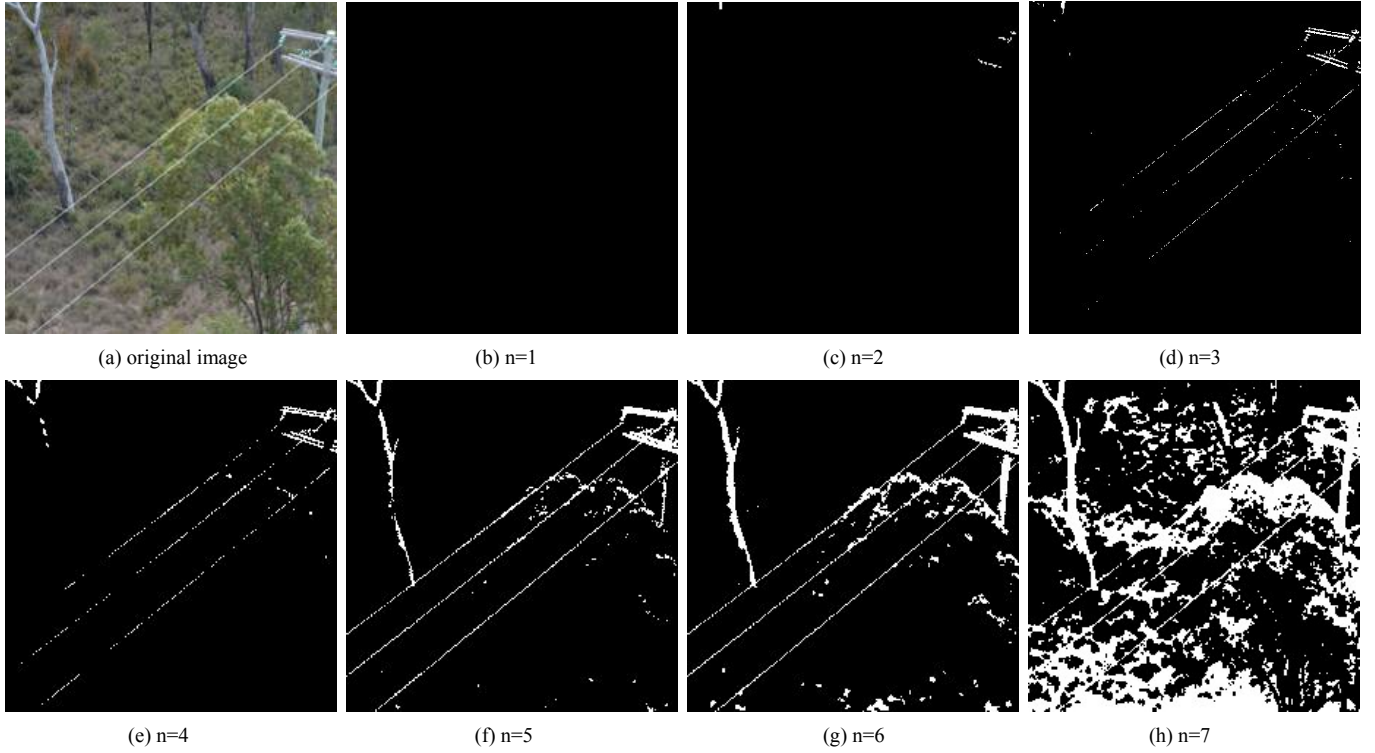

Figure 4 Original image and 7 pulsed outputs of PCNN

In this paper, we use the following rules to locate noisy pixels and remove them based on literature [11]: if pixel (i, j) pulsed and most of its neighboring neurons have not pulsed, which indicates that the intensity of this pixel is too large and can be considered as a noisy pixel. Usually this type of noise pulse the earliest during PCNN iteration. For dark noise, the same rule can be applied on the inversed image. Once noisy pixels are located, a median filter is applied to change the intensities of these noisy pixels.

Moreover, edges of the binary pulse outputs can also be detected by using the same PCNN model. The width of edge can be determined by controlling the transmitting distance of neuron pulses. In this paper, the following algorithm is used to detect edges in the binary filtered image:

Algorithm 1 Detect edges in binary image using PCNN

Input: binary image Bin

Output: one-pixel width edge set $Edge$

- 1: initialize the pulse output Y to be the binary image and save it to Y_0 : $Y_0 = Y = Bin$
- 2: calculate the linking input L using equation (7) with $3*3$ linking weight matrix
- 3: calculate the neuron internal status U using equation (8)
- 4: calculate the output the each neuron using equation (9), with a threshold larger than the minimum value of U : $\Theta = \min(U) + 0.01$; $Y = step(U - \Theta)$
- 5: the edge of image Bin can be obtained by logical operation exclusive disjunction (XOR) on Y_0 and Y : $Edge = Y_0 \oplus Y$

In summary, our proposed pulse coupled neural filter (PCNF) can be described by figure 5. The simplified PCNN is used to generate temporal pulse outputs which contain important information for discriminating image noise, target object (power line) and image background. However, there is no automatic method to determine which output contain

power lines and which just contain image noise. According to our experiments, in most cases the output of the third PCNN iteration is a safe choice because pixels corresponding to power lines pulsed and most of the background pixels have not pulsed. After that, morphological filter is applied to the binary pulse image for post-processing purpose which will make the detected object more continuous. Finally the same PCNN model is used to generate the edge image according to algorithm 1.

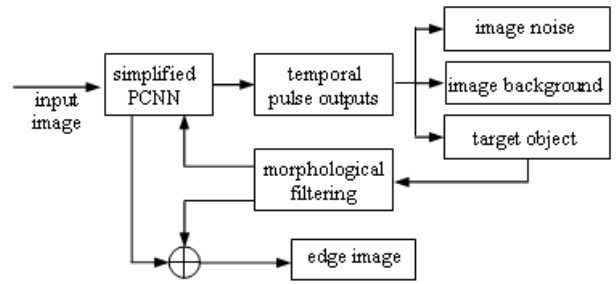

Figure 5 The structure of pulse coupled neural filter

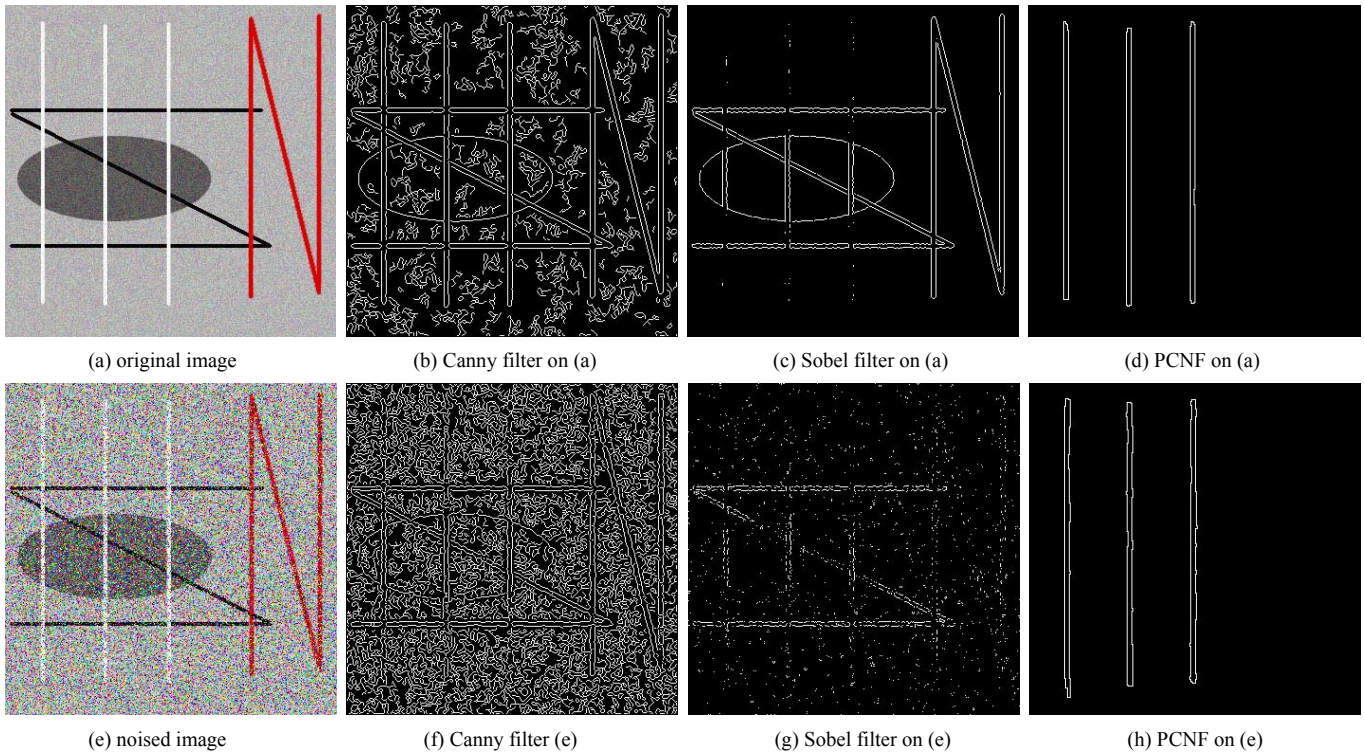

Figure 6 Comparison of Canny filter, Sobel filter and PCNF

Figure 6 compares the results using Canny filter, Sobel filter and our proposed pulse couple neural filter (PCNF) on synthetic images with and without noise. The aim of the simulation is try to detect the three light lines in images and generate the edge map. As is shown in the figure, Canny and Sobel filter try to detect any edge in image and are very sensitive to image noises. While the proposed pulse coupled neural filter (PCNF) is more flexible because it can be used to detect the interested edges rather than detect all edges in

the image. Moreover, PCNF is more robust when image is contaminated with pepper and salt noise (see the second row of Figure 6).

3.2 Knowledge-based line clustering in Hough space

Hough transform is used to detect parameterized shapes (e.g. lines, circles) through mapping each point to a new

parameter space in which the location and orientation of certain shapes could be identified [12]. When applied to detect straight lines in an image, the Hough Transform usually parameterizes a line in the Cartesian coordinate to a point in the Polar coordinate (Figure 7) based on the point-line duality using the equation:

$$x \cos(\theta) + y \sin(\theta) = \rho \quad (11)$$

Alternatively, this parameterization maps collinear points into a set of intersecting sinusoidal curves in the parameter space. The lines in the Cartesian coordinate can be estimated by detecting points of intersections of these curves (i.e., peaks) in the Polar coordinate [13]. These peaks in the parameter space can be obtained using a voting mechanism.

Hough Transform has been proven to be effective method for

line detection. However, it does have some limitations such as high computational cost and mistakable detection of spurious lines. In order to solve these problems, Fernandes and Oliveira proposed an improved Hough transform by introducing a new voting scheme to avoid the brute-force approach of one pixel voting for all potential lines [14]. Instead, the approach operates on clusters of approximately collinear pixels by using an oriented elliptical-Gaussian kernel that models the uncertainty associated with the best-fitting line with respect to the corresponding cluster. Figure 7 (a) and (b) show their voting procedures and the 3D visualization of voting maps respectively. The letters A-H indicate the clustered segments that voted to each peaks. In this paper, we extended this improved Hough transform for power line detection purpose.

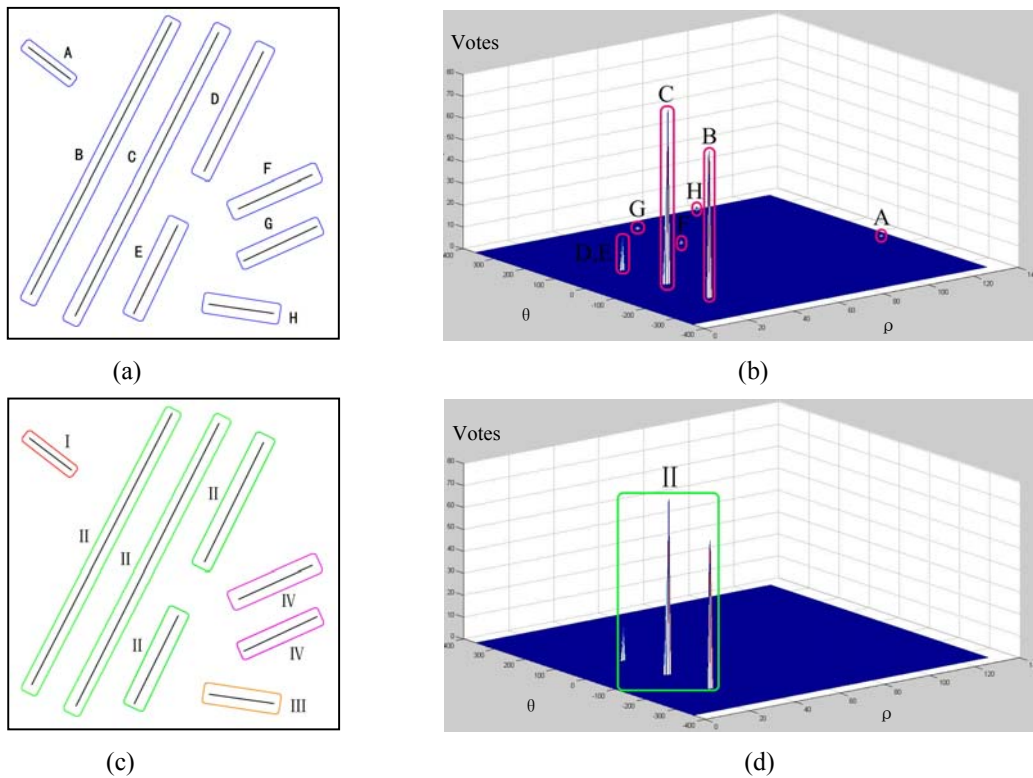

Figure 7 Voting procedures and the 3D visualization of voting maps

Hough transform is an effective tool to detect straight lines, but does not intelligently identify power lines. Any

linear objects will be detected, such as edge of roads and rivers, fences, etc. Although using PCNF can significantly

decrease the influence of other linear edges, problem still exist especially when the linear object has similar color with power lines. In order to discriminate power lines from other linear objects, we use a k-means algorithm to cluster all detected lines to identify the lines of interest.

The objective of data acquisition in our project is to achieve a low flying altitude where a typical 12mm transmission lines will be represented by at least two pixels. Therefore, each power line is detected as at least two Hough lines in the edge image. Power lines are almost parallel with very similar angles, and a power line is usually the longest line as it crosses the entire image, while other detected lines do not have this regular property. Based on this idea, a cluster schema is employed in the Hough transform voting procedure to group the parallel lines and output the cluster with largest summation of votes as candidate powerlines (as shown in Algorithm 2). Figure 7 (c) and (d) illustrate this clustering schema and show the 3D visualization of voting maps. Parallel lines are grouped together and the cluster with largest summation of votes indicates that the dominate lines of the image are in this cluster.

Algorithm 2 Knowledge-based line clustering in the Hough space

Input: detected Hough line set $Ls(\rho, \theta, votes)_i (i = 1, 2, \dots, n)$, where n is the number of detected lines, ρ and θ are the coordinates of pixels in Hough parameter space, $votes$ is the accumulate number of votes of each detected Hough line.

Output: candidate power lines $CPLs$

- 1: calculate the line groups $C_j (j = 1, 2, \dots, k)$ using K-means on θ values of $Ls_i (i = 1, 2, \dots, n)$, where k is the number of line clusters (in this paper we choose $k = 4$).
- 2: calculate the summation of votes in each cluster

$$SumVotes_j = \sum_{i=1}^k Ls(votes)_i$$

- 3: find the cluster C_m with largest value of $SumVotes$, where $SumVotes_m = \max(SumVotes_j) (j = 1, 2, \dots, k)$
 - 4: output the lines in cluster C_m as candidate power lines
- $CPLs = C_m$

4 Experiment and discussion

The experiment is performed on real image data captured from two Unmanned Aerial Vehicle (UAV) platforms: V-TOL Aerospace *BAT-3*, and ARCAA UAV platform *Eleanor* (Figure 8).

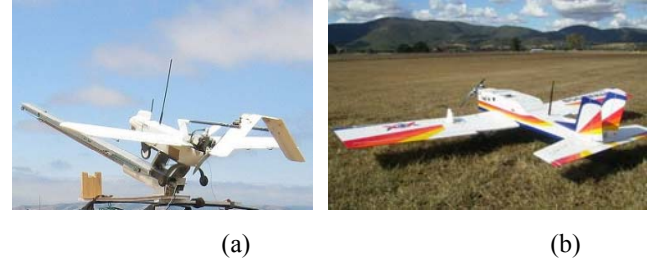

Figure 8 UAV platforms: (a) BAT-3; (b) Eleanor

In the experiment, we compare Hough line detection results on edge maps generated from Canny and our proposed pulse coupled neural filter (PCNF). The results before and after using knowledge-based line clustering in Hough space are also compared. As is shown in Figure 9 (a), there are many linear features in the original image: power lines, edges of road, shadows, etc. These linear features are detected by Hough transform (see Figure 9 (c), shown in red lines). Although some of these lines can be eliminated by applying knowledge based post-processing, lines such as road edges are not removed because they are parallel to power lines (see Figure 9(d), shown in green lines). A better choice is trying to avoid the misleading information before detecting power lines. In this paper, we use the proposed PCNF for preliminary detection of power lines and edge maps generation. It can be seen from Figure 9 (e) that most irrelevant points are filtered, though a few noises still exist.

This is because PCNF has the characteristic of grouping pixels according to the space or gray similarity. It reduces the local gray differences of images and makes up local tiny discontinuous points in image regions. Power lines are made of special metal and have uniform brightness on images while the background is different on textures and intensities. Neurons stimulated by power lines generate different spectral stimuli from that of the background, and then they pulse non-synchronously. Thus, power lines are discriminated from the background. According to our experiment, pulse output of PCNF at the third iteration is a safe choice because pixels corresponding to power lines pulsed and most of the background pixels have not pulsed at that time. However, automatic selecting of temporal pulse

outputs is required in the future work. From Figure 9 (g) and (h), we can see that after using PCNF, power lines are correctly detected no matter using knowledge based post-processing or not. It should be mentioned that this approach is not perfect. Metallic fence line is also detected (see the left line in Figure 9), because it has very similar characteristics with power lines. In Australia, it is not uncommon that the fence lines are existed in power line corridor and in many cases they are parallel to power lines. Future work is to discriminate these very mistakable linear features (e.g. paralleled fence lines) from power lines. Prospective improvement is to discriminate them by incorporating more knowledge. For example, the width of power lines and the spatial relationship with power poles.

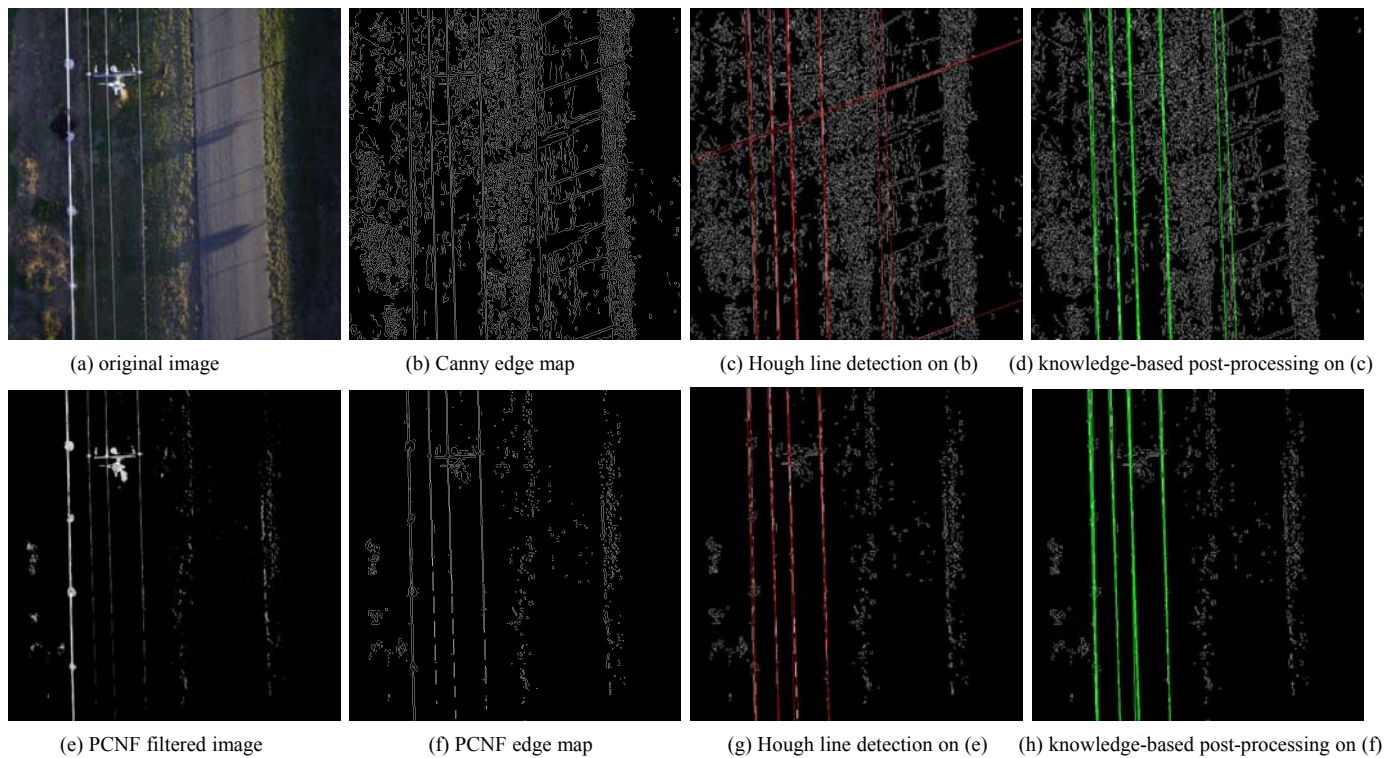

Figure 9 Comparison of power line detection results

Figure 10 shows more results of the experiment. The first row is the original images. Row 2 and Row 3 are Hough line detection results on Canny edge image and PCNF edge

image without using knowledge-base post-processing. Row 4 and row 5 are the results after using knowledge based line clustering. From the experiment, it is clear that the proposed

pulse coupled neural filter (PCNF) is very useful as a pre-processing tool. Most noises are filtered and power lines are prominent in the images. After using PCNF, fewer irrelevant lines exist. Applying knowledge-based post-processing by clustering lines in the Hough space also increases the accuracy of power line detection. Combination of these techniques can significantly increase the accuracy of power line detection in the complex environment.

5. Conclusion

In this paper, a novel method is proposed specifically for power line detection from aerial images. First, a pulse couple neural filter is developed to remove the background noise and generating edge map prior to Hough transform being employed to detect straight lines. After that a knowledge based line clustering is performed in the Hough space to refine the detection results. The experiment on real image data captured from our UAV platforms demonstrates that the proposed approach can significantly increase the accuracy of power line detection in complex environment.

Acknowledgement: This research is sponsored by CRC-SI project 6.07: spatial information business improvement at Ergon Energy.

REFERENCES

1. Appelt, P.J. and J.W. Goodfellow, *Research on How Trees Cause Interruptions- Applications to Vegetation Management*, in *IEEE Rural Electric Power Conference*. 2004: Scottsdale, Arizona.
2. Beck, K. and R. Mathieu, *Can Power Companies use Space Patrols to Monitor Transmission Corridors?*, in *ESRI User Group Conference*. 2004: San Diego.
3. Russell, B.D., et al., *Reliability Based Vegetation Management Through Intelligent System Monitoring*, in *Power Systems Engineering Research Center*. 2007, Texas A&M University: Texas.
4. Berni, J.A.J., et al., *Thermal and Narrowband Multispectral Remote Sensing for Vegetation Monitoring From an Unmanned Aerial Vehicle*. IEEE Transactions on Geoscience and Remote Sensing, 2009. **47**(3): p. 722-738.
5. Golightly, I. and D. Jones, *Visual Control of an Unmanned Aerial Vehicle for Power Line Inspection*, in *12th International Conference on Advanced Robotics*. 2005: Seattle, WA.
6. Yan, G., et al., *Automatic extraction of power lines from aerial images*. IEEE Geoscience and Remote Sensing Letters, 2007. **4**(3): p. 387-391.
7. Ma, Y., et al., *Principle and Applications of Pulse-Coupled Neural Networks*. 2005, Beijing: Science Press.
8. Eckhorn, R., et al., *A neural network for feature linking via synchronous activity: Results from cat visual cortex and from simulations*, in *Models of Brain Function*, R.M.J. Cotterill, Editor. 1989, Cambridge University Press: Cambridge. p. 255-272.
9. Forgáč, R. and I. Mokriš. *Formal Representation of Images by Pulse Coupled Neural Networks*. in *3rd Slovakian-Hungarian Joint Symposium on Applied Machine Intelligence 2005*. Slovakia.
10. Lindblad, T. and J.M. Kinser, *Image Processing Using Pulse-Coupled Neural Networks*. Second ed. 2005: Springer. 161.
11. Zhang, J., J. Dong, and M. Shi, *An Adaptive Method for Image Filtering with Pulse-coupled Neural Networks*, in *IEEE International Conference on Image Processing (ICIP)*. 2005: Genova, Italy.
12. Aggarwal, N. and W.C. Karl, *Line Detection in Images Through Regularized Hough Transform*. IEEE Transactions on Image Processing, 2006. **15**(3): p. 582-591.
13. Agganval, N. and W.C. Karl, *Line Detection in Images Through Regularized Hough Transform*, in *International Conference on Image Processing 2000*: Vancouver, BC
14. Fernandes, L.A.F. and M.M. Oliveira, *Real-time line detection through an improved Hough transform voting scheme*. Pattern Recognition, 2008. **41**: p. 299-314.

Row 1:
Original images



Row 2:
Hough line
detection on Canny
edge map

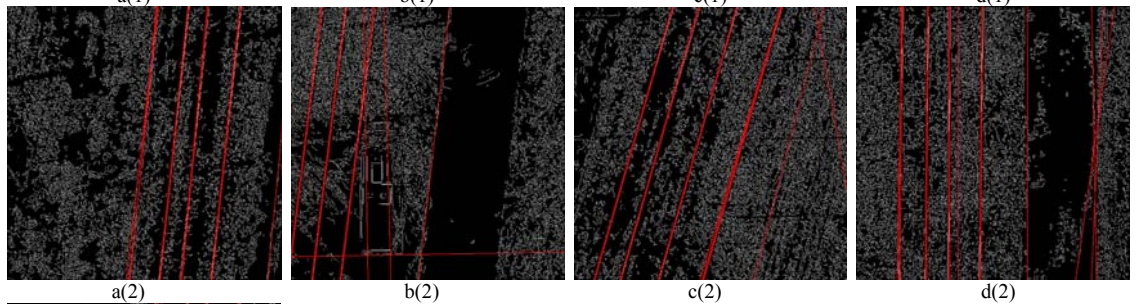

Row 3:
Hough line
detection on PCNF
edge map

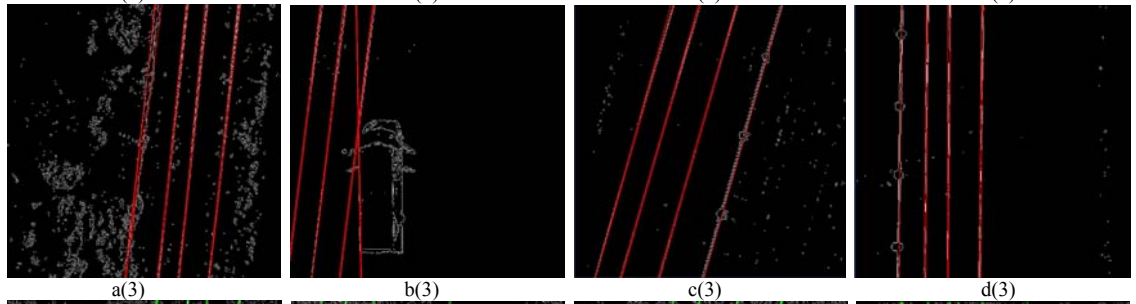

Row 4:
Knowledge-based
post-processing on
row 2

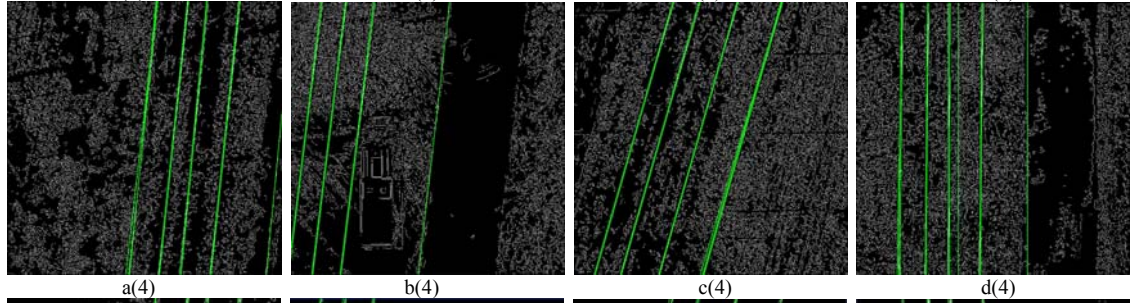

Row 5:
Knowledge-based
post-processing on
row 3

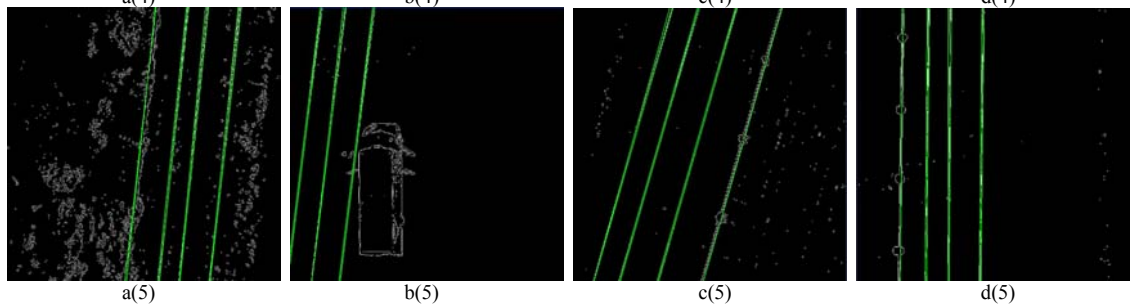

Figure 10 Experimental results on real image data captured from UAV Platforms