

A Method for Anchoring Round Shaped Cells for Atomic Force Microscope Imaging

S. Kasas and A. Ikai

Tokyo Institute of Technology, Faculty of Biosciences, 4259 Nagatsuta, Midoriku, Yokohama 227, Japan

ABSTRACT More and more researchers are interested in imaging living (Henderson, 1994) or fixed cells in their natural environment using the atomic force microscope (AFM). However, the AFM tip interacts strongly with the sample, and its z range freedom is limited to a few micrometers. This means that the cells to be imaged have to be strongly attached to the substrate, and imaging is restricted to cells having a flattened shape. Here we propose a simple and inexpensive solution to overcome these limitations. The method we propose is trapping living round shaped cells in a Millipore filter with a pore size comparable to the dimensions of the cell. The highest part of some of the blocked cells protrude through the holes of the filter and can this way be easily observed using the AFM without detachment.

INTRODUCTION

The atomic force microscope (AFM) developed by Binnig and co-workers (Binnig et al., 1986) belongs to the new, rapidly growing family of scanning probe microscopes. The AFM consists of a tip at the end of a cantilever that is placed in contact with the sample (Wickramasinghe, 1989). Piezoelectric crystals scan the sample under the tip, and the minute deformations of the lever are detected and recorded by a computer to reproduce the sample's topography. The AFM allows the observation of conducting and non-conducting samples with high lateral and vertical resolutions, in vacuum, air, and liquids (Manne et al., 1990). Additionally the microscope can probe some physical properties such as friction and softness on a nanometric scale. All these possibilities make this instrument very useful in several biological applications, and up to now a very large number of biological samples have already been observed with the AFM (Radmacher et al., 1992). The observation of living cells using this instrument is a very exciting, but for the moment quite difficult research field. The difficulty is due to the limited capability of the microscope to image soft, high, and rough samples in addition to the main difficulty in fixing the sample to the substrate in liquid, which is the key point for obtaining good resolution images. Soft samples are deformed by the tip and rough ones cannot be imaged, because the vertical motion of the tip is limited to 5–15 μm , depending on the type of the instrument. Additionally there are strong interactions between the tip and the sample that limit the lateral resolution of the microscope by moving the loosely attached particles or even cells right and left during the scan. Nevertheless, the new insights this microscope can give about the morphology, dynamics (Fritz et al., 1994), and

mechanical properties (Shroff et al., 1994) of living cells are so exciting that they largely motivate efforts to overcome these limitations. One of these challenges is to fix biological samples to the substrate under physiological conditions. The problem can sometimes be solved by choosing flat and well adhering cell types (Kasas et al., 1993). Stable scanning over spherical-shaped cells is much more difficult to achieve. A very elegant solution, although technically difficult to set up, was developed by Horber et al. (1992). It consists of trapping a single cell at the mouth of a micropipette and imaging the protruding part by the AFM. This technique has several advantages. Any cell type can be observed, and there is no height problem any more, because the microscope is directly engaged on the cell. Another advantage of this method is that it keeps the cell membrane stretched, which significantly increases the resolution of the AFM images. Additionally, electrophysiological experiments can be carried on simultaneously. However, the disadvantage is the heavy instrumentation needed in this method.

The solution proposed here is a combination of the preceding two techniques. The cells to be observed are grown in suspension in the presence of a Millipore filter with a pore size slightly smaller than the diameter of the cells. While being cultured, some cells are trapped in the holes and a part of their cell body protrudes outside. This part of the membrane is thus accessible to AFM imaging. A similar trapping can be achieved by passing the cell suspension through the filter placed in a modified syringe. In spite of the fact that this method allows the observation of just a small part of the cell surface this part is stretched and a reasonable resolution can be obtained. A very similar sample trapping technique was independently developed by Holstein et al. (1994) to immobilize and dissect fixed *Hydra vulgaris* polyps.

MATERIALS AND METHODS

Commercially available *Saccharomyces cereviceae* (dried form) were grown overnight in tap water in 20% sucrose in the presence of 5 μm pore size millipore filters in a shaking bath at 30°C. The filters were removed from the liquid, stuck on a coverglass using double-faced adhesive tape, and fixed again on a small metallic disc for AFM observation.

Received for publication 18 November 1994 and in final form 2 February 1995.

Address reprint requests to Dr. Sandor Kasas, c/o Professor A. Ikai, Faculty of Biosciences, 4259 Nagatsuta, Midoriku, Yokohama 227, Japan. Tel.: 81-459-2457-39; Fax: 81-459-2458-05.

© 1995 by the Biophysical Society

0006-3495/95/05/1678/03 \$2.00

Some of the samples were prepared by pushing yeast cell suspensions through a modified syringe system depicted in Fig. 1.

In this case, just before the observation, a millipore filter was placed on piston *d*, the yeast cell suspension was injected on it, and the liquid was squeezed through the filter using piston *a*. The filter was then removed and fixed on a metallic disc in the same way as described for the first experiment. In some experiments we did not push on the piston at all but let the liquid be filtered by gravity. In this case again we obtained trapped yeast cells in the filter.

In all cases we scanned the glossy face of a filter.

Samples were imaged by contact mode Nanoscope III AFM (Digital Instruments, Santa Barbara, CA) operating under sucrose solution. We used the 0.023 nN spring constant cantilevers and a D scanner (15.9 μm maximal scanning size).

RESULTS

We were able to distinguish three different types of immobilized cells: those that are protruding from pores (type I), those deeply encrusted in them (type II), and those that lie on a filter being stuck on it (type III). Figs. 2 and 3 represent examples of each type. The cells that were just lying on a filter were, as expected, the first to be removed by the tip. If some of them were anchored strongly enough to be observed, the resolution we obtained at their surface was poor. The first two types were in contrast much more stable. Several of them were imaged for more than 1 h without being removed. The resolution we obtained on the cells protruding out of the hole and those deeply anchored in them was similar but generally better than that obtained on type III cells.

In some cases, trapped cells disappeared during the repeated scanning by AFM. This only happened to the cells deeply immobilized in a pore, which probably had a diameter equal to or smaller than the pore size. Type II cells were observed more frequently than those of type I.

Because most of the cells were either deep in the pore or protruding from it, a strong tip effect was observed at the edges of most of the cells. Such an effect is produced when the tip touches a sample with its sides. Such a case is shown in Fig. 4 and graphically explained in Fig. 5. Sometimes this

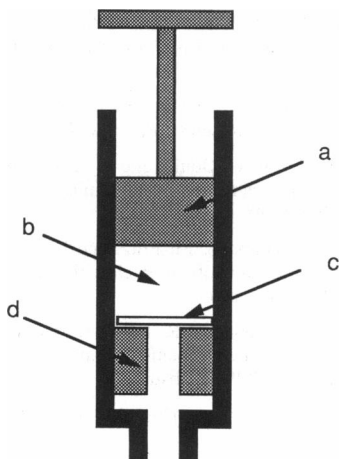

FIGURE 1 The modified syringe. (a) Piston. (b) Suspension of yeast cells. (c) Millipore filter. (d) Piston with a central hole.

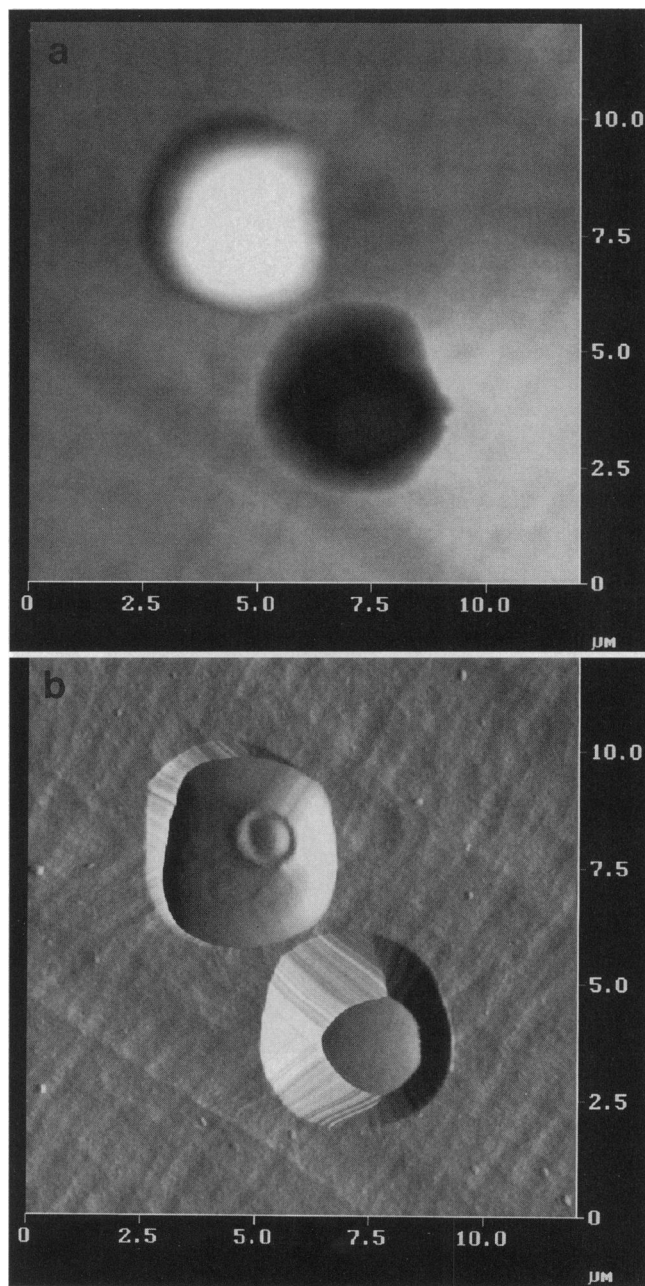

FIGURE 2 Constant force (a) and error (b) mode images of yeast cells protruding (up) from (type I) and encrusted (bottom) in (type II) the pores.

effect can deform structures located on the sides of the observed cell as for the two bud scars visible on the right side of the cell in Fig. 6.

CONCLUSION

The millipore filter has been used as a very convenient support for the observation of medium-sized biological samples in air (Kasas et al., 1994). In this report we show that the filter can also be used in liquids to immobilize in their pores round-shaped organisms of micrometer scale such as yeast cells. We believe that this technique can be extended to bacteria

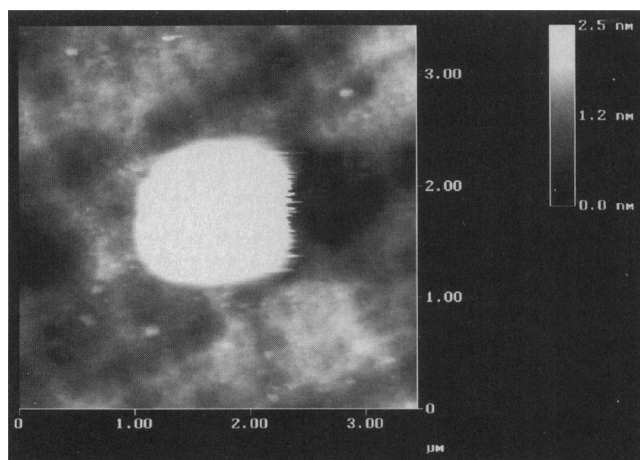

FIGURE 3 Yeast cell lying on the surface of the filter (type III). Constant force mode image.

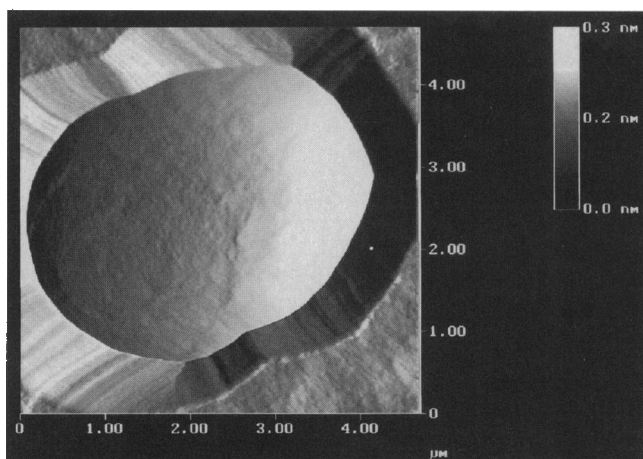

FIGURE 4 Yeast cell trapped in a pore and surrounded by an artifactual structure due to the contact of the borders of the AFM tip with the edges of the pore.

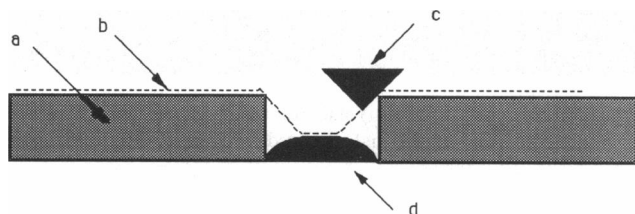

FIGURE 5 (a) Millipore filter. (b) Path of the tip. (c) AFM tip. (d) yeast cell.

and living plant, mammal, or insect cells. Because the method is simple, inexpensive, and easily used with all the commercially available AFM microscopes, it will be widely applicable in anchoring living cells for the observation of their topography, mechanical properties, or dynamics of living organisms.

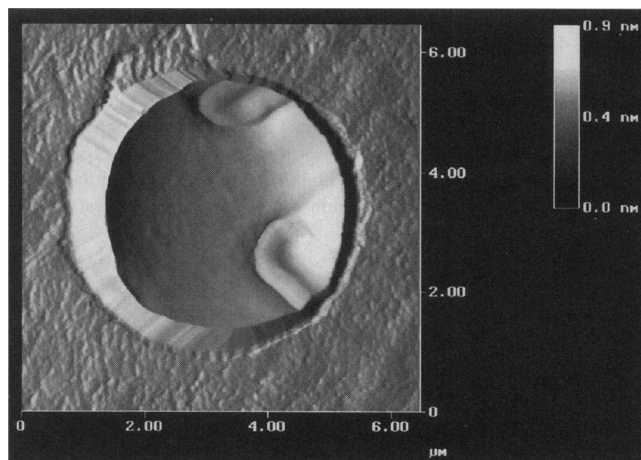

FIGURE 6 The crater-like structures are bud scars. The two scars of this figure are located laterally and therefore are considerably deformed on their lower part. An undeformed scar is visible on Fig. 2.

The authors thank M. Gad and M. R. Celio for their highly constructive suggestions.

This work was supported by the Swiss National Science Foundation (grant 31-33753.92) and the Nissan Foundation for the Promotion of Science.

REFERENCES

- Binnig, G., C. F. Quate, and C. Gerber. 1986. Atomic force microscope. *Phys. Rev. Lett.* 12:930-933.
- Fritz, M., M. Radmacher, and H. E. Gaub. 1994. Granula motion and membrane spreading during activation of human platelets imaged by atomic-force microscopy. *Biophys. J.* 66:1328-1334.
- Henderson, E. 1994. Imaging of living cells by atomic-force microscopy. *Prog. Surf. Sci.* 46:39-60.
- Holstein, T. W., M. Benoit, G. v. Herder, G. Wanner, C. N. David, and H. E. Gaub. 1994. Fibrous mini-collagens in hydra nematocysts. *Science.* 265:402-404.
- Horber, J. K. H., W. Haberle, F. Ohnesorge, G. Binnig, H. G. Liebich, C. P. Cserny, H. Mahnel, and A. Mayr. 1992. Investigation of living cells in the nanometer regime with the scanning force microscope. *Scanning Microsc.* 6:919-930.
- Kasas, S., B. Fellay, R. Cargnello, and M. R. Celio. 1994. Observation of the action of penicillin on *B. subtilis* using the atomic force microscope: technique for the preparation of bacteria. *Surf. Interface Anal.* 21:400-401.
- Kasas, S., V. Gotzos, and M. R. Celio. 1993. Observation of living cells using the atomic force microscope. *Biophys. J.* 64:539-544.
- Manne, S., H.-J. Butt, S. A. C. Gould, and P. K. Hansma. 1990. Imaging metal atoms in air and water using the atomic force microscope. *Appl. Phys. Lett.* 56:1758-1759.
- Radmacher, M., R. W. Tillmann, M. Fritz, and H. E. Gaub. 1992. From molecules to cells: imaging soft samples with the atomic force microscope. *Science.* 257:1900-1905.
- Shroff, S. G., Saner D. R., and Lal R. 1994. Atomic-force microscopy of atrial cells: local viscoelastic mechanical-properties and imaging of cytoskeleton. *Biophys. J.* 66:278a. (Abstr.)
- Wickramasinghe, H. K. 1989. Scanned-probe microscopes. *Sci. Am.* 260: 98-105.