



2nd International Conference on Sustainable Energy Engineering and Application, ICSEEA 2014

## Maximum power point tracking for photovoltaic using incremental conductance method

Ratna Ika Putri<sup>a,\*</sup>, Supto Wibowo<sup>b</sup>, Muhamad Rifa'i<sup>a</sup>

<sup>a</sup>Department of Electronic Engineering, State Polytechnic of Malang, Soekarno Hatta Street, Malang, Indonesia

<sup>b</sup>Department of Electrical Engineering, State Polytechnic of Malang, Soekarno Hatta Street, Malang, Indonesia

---

### Abstract

Solar energy is a potential energy source in Indonesia. A photovoltaic is needed to harvest this kind of energy, and to be able to gather the most, the PV must have a good efficiency. The maximum efficiency is achieved when PV works at its maximum power point which depends on irradiation and temperature. Since the irradiation and temperature always change with time, a PV system which able to track the maximum power point needs to be developed to produce more energy. This research was aimed to explore the performance of a maximum power point tracking system which implements Incremental Conductance (IC) method. The IC algorithm was designed to control the duty cycle of Buck Boost converter and to ensure the MPPT work at its maximum efficiency. The system performance of IC algorithm was compared to widely used algorithm - Perturb and Observe (P&O) on a Simulink environment. From the simulation, the IC method shows a better performance and also has a lower oscillation.

© 2015 The Authors. Published by Elsevier Ltd. This is an open access article under the CC BY-NC-ND license (<http://creativecommons.org/licenses/by-nc-nd/4.0/>).

Peer-review under responsibility of Scientific Committee of ICSEEA 2014

*Keywords:* photovoltaic; MPPT; incremental conductance; buckboost converter

---

### 1. Introduction

One of potential renewable energy source which offers a replacement to fossil energy is solar energy. Indonesia lies on equator therefore can get the benefit of availability of solar energy all days in year. The potency of solar energy in Indonesia is around 4.8 kWh/m<sup>2</sup>/days with monthly variance of 9%. A preliminary survey on solar

---

\* Corresponding author. Tel.: +62-341- 404420

E-mail address: [ikaputri\\_ratna@yahoo.com](mailto:ikaputri_ratna@yahoo.com)

intensity resource assessment in Indonesia has been conducted based on sun spot number, latitude and rain fall analysis [1]. Photovoltaic is needed to harvest the solar energy, and it has some advantages such as environment friendly and low maintenance cost. The main disadvantages of PV are it needs a high installation cost and it has a low efficiency (less than 20%) [2]. To improve its efficiency, a PV must work at maximum power point which is always change depends on sun irradiation and temperature. A change of temperature and irradiation shifts the maximum power point and reduce the PVs efficiency [3]. The maximum power point tracking (MPPT) usually is implemented by a power electronic circuit which provides an interface between PV and load [4].

Some researchers were conducted to optimize PV by using some methods, for instance: Constant voltage control, Perturb & Observe, Incremental Conductance, Fuzzy Logic and Neural Network. Constant voltage control is a simple method and it has been implemented for traffic light application [5]. Perturb & Observe methods or also well known as Perturbation Methods is widely used since the implementation is simple. One drawback of this method is its disturbance increases along with the power and after the power of PV reaches the peak, the power will decrease and the disturbance becomes bigger [4]. Another drawback of its method is it introduce an oscillation on maximum power point area and not suitable to implement at an environment which suffer from rapid changes of temperature and irradiant [11]. Other alternative of MPPT methods are Fuzzy Control and Neural Network [7][8][12]. Fuzzy control has been used to control Boost converter in an electric car which is powered by solar energy [7]. Fuzzy control and Neural Network deteriorate from the complexity of fuzzy rules design process and also depend on learning process [7][8][12]. Among those methods, Incremental Conductance (IC) offers a better performance, faster tracking time and has no oscillation [6][11][9][10].

A DC to DC converter is needed for implementing MPPT. The DC-DC converter delivers the maximum power from PV module to load by adjusting the duty cycle and able to distribute a maximum power when load is changes [5]. Some common DC-DC converter topologies for implementing MPPT are Buck converter, Boost converter, Cuk converter, Full bridge converter and Buck Boost converter. The performance of IC method outperformed the PO method when it implemented at Buck converter or Boost converter [6]. Another research had shown that implementing IC method on Cuk converter also able to find the maximum power point and had an efficient performance on some different weather condition [10].

This research was dealing with implementation of IC on Buck Boost converter by adjusting its PWM duty cycle. Buck Boost converter generates bigger or lower voltage output depends on the duty cycle. The system was simulated on Simulink by injecting some irradiant and temperature changes during simulation periods. The IC was observed its capability to retain the system to works at the maximum power point and the performance was compared to PO method.

**2. Photovoltaic model**

Photovoltaic system is an apparatus for converting solar energy to DC electric power. A PV is characterized by its short circuit current ( $I_{sc}$ ), open circuit voltage ( $V_{oc}$ ), maximal voltage ( $V_{max}$ ) and MPP current. Those parameters shape the I -V and P-V characteristic curve. The PV output voltage also depends on the load. A PV commonly can be modeled by one diode and two diodes. Two diodes model is more accurate but it needs more variables hence the model is more complex [4]. Regarding that condition, this research was carried out by using one diode model. The PV itself is a nonlinear system and can be defined as a variable current source as shown on Fig 1.

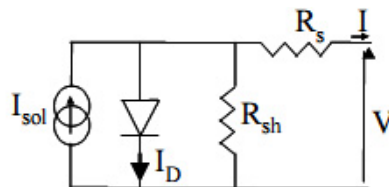

Fig. 1. solar cell equivalent circuit.

The current generated by PV can be calculated by using this equations:

$$I = I_{sol} - I_D \quad (1)$$

$$I_D = I_{OS} \left( \exp \left( \frac{q(V + R_s I)}{kT} \right) - 1 \right) \quad (2)$$

$$I_{os} = I_{or} \left( \frac{T}{Tr} \right)^3 \exp \left[ \frac{qE_{GO}}{\beta k} \left( \frac{1}{Tr} - \frac{1}{T} \right) \right] \quad (3)$$

$$I_{sol} = [I_{SC} + K_i(T - 298.18)] \frac{\lambda}{1000} \quad (4)$$

where I and V are output current and output voltage of solar cell, IOS is diode's reverse saturation current, T is temperature in Kelvin, K is Boltzman constant ( $1,381e-23$  J/K), q is electric charge, ISC is short circuit current at temperature of 25°C, Ki is temperature constant at ISC,  $\lambda$  is sun irradiation in  $W/m^2$ ,  $I_{sol}$  is solar cell output current,  $\gamma$  is ideality factor, Tr is reference temperature (298,18K) and I or is saturation current at Tr. Current output also is influenced by diode's ideality factor and the range is between 1 and 2[8]. Photovoltaic model was simulated by using Matlab Simulink as shown on Fig. 2.

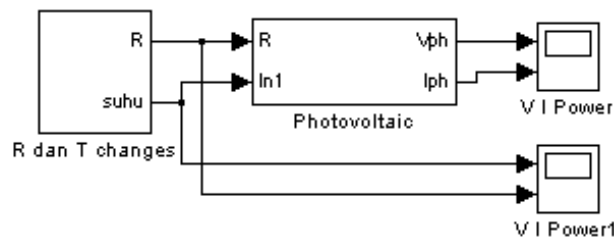

Fig. 2. Photovoltaic model in Matlab Simulink.

### 3. MPPT method

Maximum Power Point Tracking (MPPT) is an electronic system which operates PV to gain a maximum power. MPPT is not a mechanical tracking however a MPPT can be used simultaneously with a mechanical tracking system [16]. Maximal Power Point (MPP) does not lie at a particular point but it moves around P-V curve depends on light intensity and temperature. The widely known MPPT algorithm is P&O and the flowchart of this algorithm can be seen on Fig. 3.

The key point of P&O methods is by comparing recent PV power ( $P_n$ ) with the previous photovoltaic power ( $P_{n-1}$ ). Photovoltaic power is determined by measuring current (I) and voltage (V). When the different between previous power and recent power is not 0, this algorithm will try to find the optimal point in the left or right side of recent position. The maximum power is obtained when  $\Delta P$  is equal to 0 [10][11]. P&O method is implemented on buck-boost by adjusting the PWM's duty cycle. If the recent power is bigger than the previous, the duty cycle will be increased until the MPP is found [14]. The drawback of this method is it introduces an oscillation on the steady state and the voltage variation is large [6]. This method also needs a long tracking time and it has a slow response to the irradiant and temperature changes.

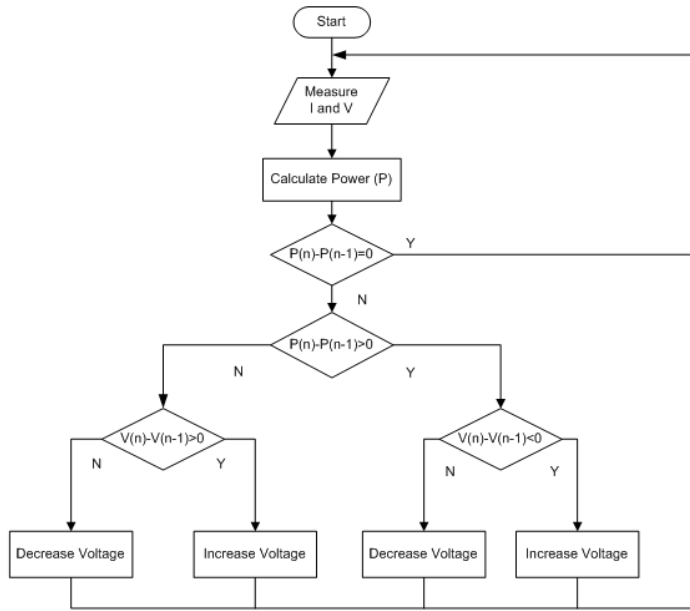

Fig. 3. Perturb & Observe flowchart.

#### 4. Incremental conductance method

Incremental Conductance was designed based on an observation of P-V characteristic curve. This algorithm was developed in 1993 and was intended to overcome some drawback of P&O algorithm. IC tries to improve the tracking time and to produce more energy on a vast irradiation changes environment[4]. The MPP can be calculated by using the relation between  $dI/dV$  and  $-I/V$ .

If  $dP/dV$  is negative then MPPT lies on the right side of recent position and if the MPP is positive the MPPT is on left side[12]. The equation of IC method is:

$$\frac{dP}{dV} = \frac{d(V.I)}{dV} = I \frac{dV}{dV} + V \frac{dI}{dV} \tag{5}$$

$$= I + V \frac{dI}{dV} \tag{6}$$

MPP is reached when  $dP/dV=0$  and

$$\frac{dI}{dV} = -\frac{I}{V} \tag{7}$$

$$\frac{dP}{dV} > 0 \text{ then } V_p < V_{mpp} \tag{8}$$

$$\frac{dP}{dV} = 0 \text{ then } V_p = V_{mpp} \tag{9}$$

$$\frac{dP}{dV} < 0 \text{ then } V_p > V_{mpp} \tag{10}$$

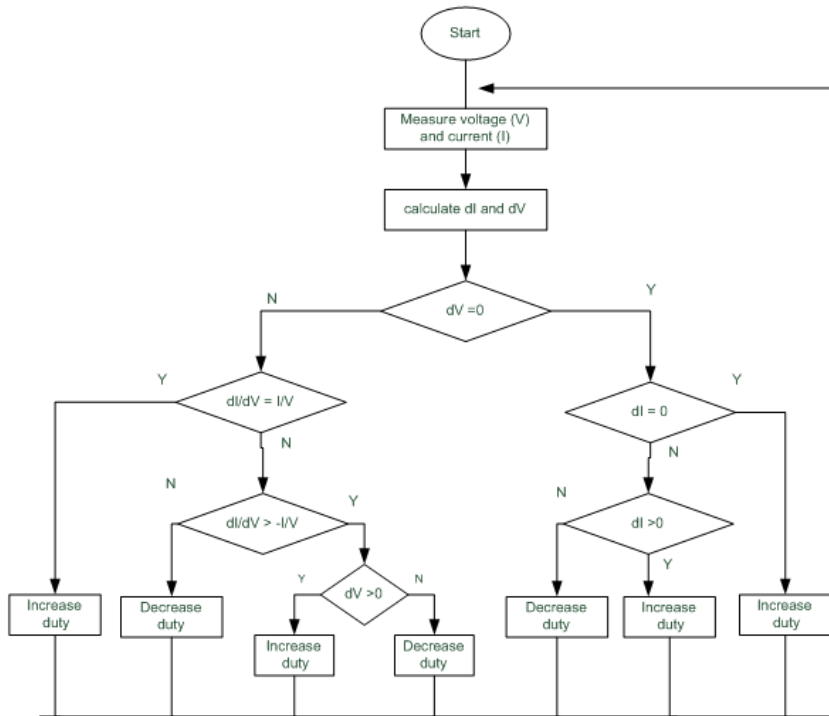

Fig. 4. incremental conductance flowchart

If MPP lies on right side,  $dI/dV < -I/V$  and then the PV voltage must be decreased to reach the MPP [9]. IC methods can be used for finding the MPP, improve the PV efficiency, reduce power loss and system cost [14]. Implementation IC on a microcontroller produced more stable performance when it compared to P&O [13]. The oscillation around MPP area also can be suppressed in trade of with its implementation complexity. Tracking time still not fast since the voltage increment and decrement had been selected manually by trial and error. IC algorithm can be seen on Fig. 4.

**5. Results and discussion**

System block diagram as shown on Fig. 5 comprises of a Photovoltaik, Buck-boost converter and MPPT Algorithm.

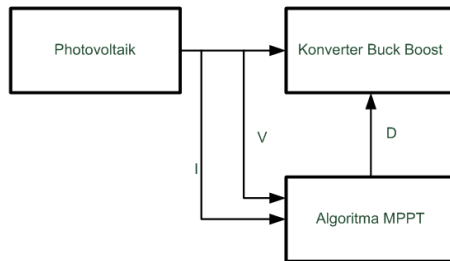

Fig. 5. Block diagram of PV system with MPPT algorithm.

MPPT algorithm was designed to simulate in Matlab by using SimPower System Toolbox. Simulink’s model of buck boost converter can be seen on Fig. 6. The Mosfet switching frequency was 200 KHz and the duty cycle was adjusted by the MPPT algorithm. Output voltage of buck boost converter depending on the duty cycle is dependent on duty cycle that can be expressed by equation.

$$V_{out} = \frac{D}{1-D} V_{in} \tag{11}$$

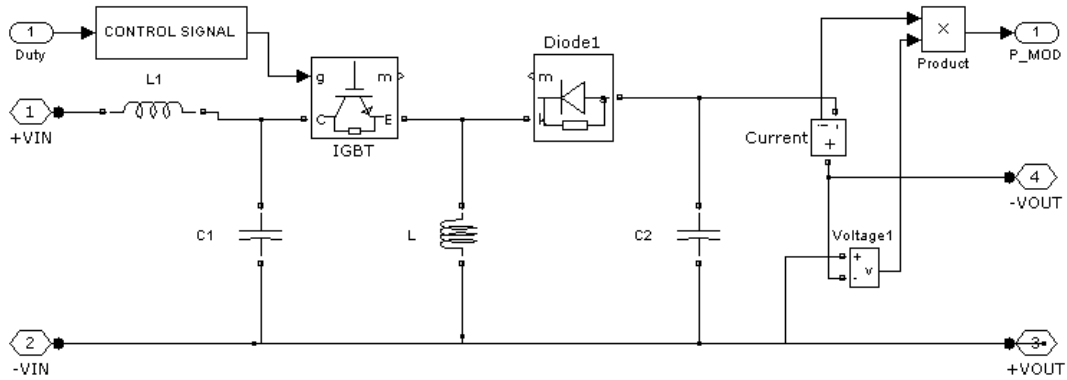

Fig. 6. Matlab Simulink model for Buck Boost Converter

Fig. 7 shows the PV model using Incremental Conductance MPPT algorithm. Simulation was carried out by giving an irradiation changes on a constant temperature 30°C. First stage of simulation irradiation was 450 W/m<sup>2</sup> then changed rapidly to 1,000 W/m<sup>2</sup> and then dips to 800 W/m<sup>2</sup> on the last stage. Simulation result of P&O method is shown on Fig. 8 and Fig. 9 shown the IC algorithm result.

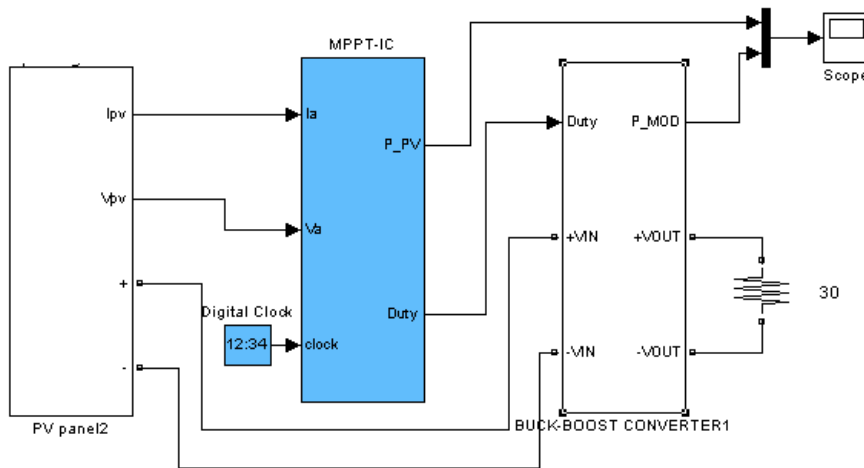

Fig. 7. PV system with incremental conductance MPPT

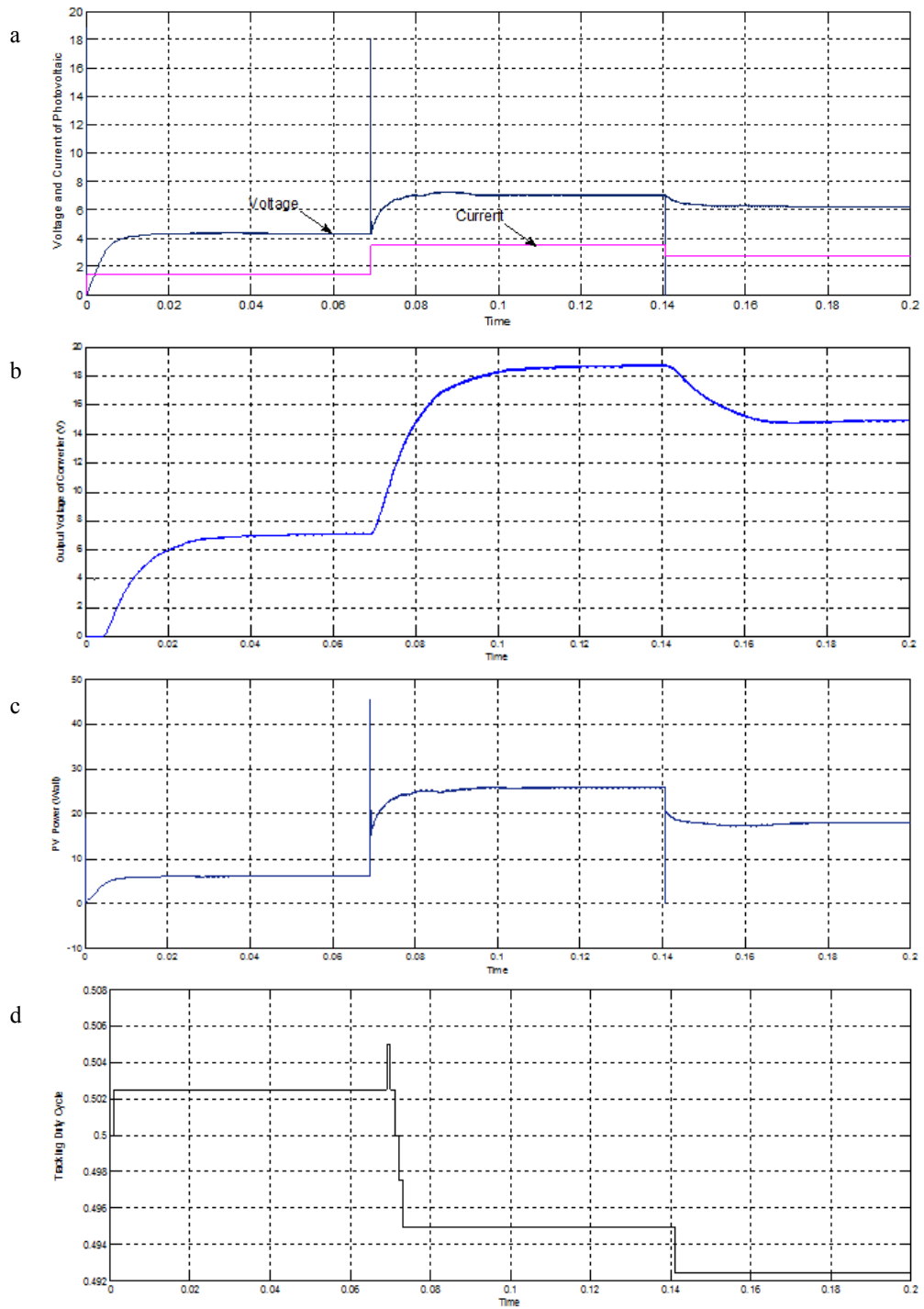

Fig. 8. Simulation result Perturb and Observe MPPT; (a). Voltage and Current; (b) DC-DC converter output voltage; (c) MPPT Output Power; (d) Duty Cycle tracking signal.

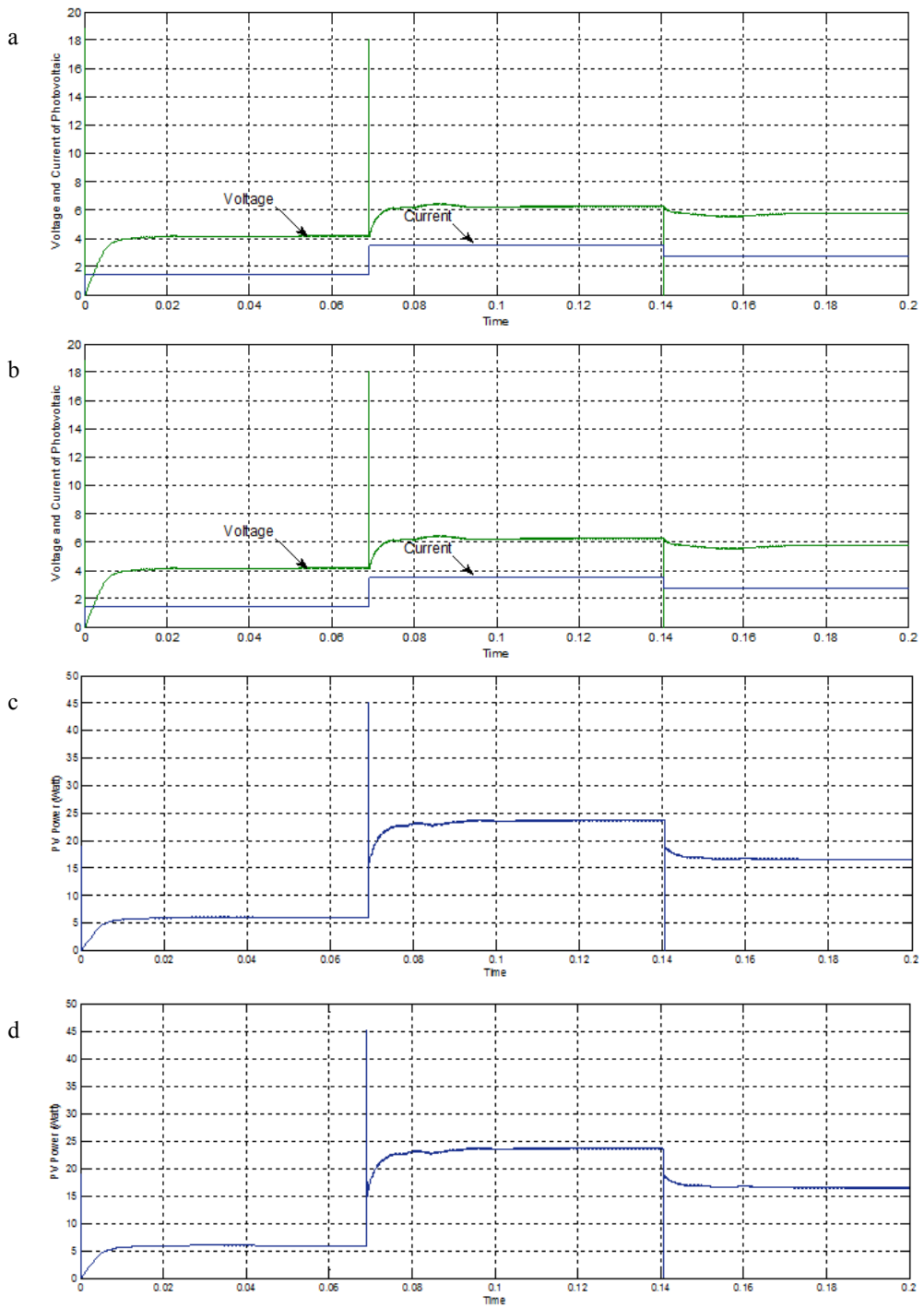

Fig. 9. Simulation result Incremental Conductance MPPT; (a) Voltage and current; (b) Converter output voltage; (c) MPPT Output Power; (d) Duty Cycle tracking signal



Based on simulation results, it was observed that two methods were able to follow irradiation changes and retain the optimal point. Incremental Conductance algorithm had proved able to detect irradiation changes and had successfully shifted the MPP by adjusting the PWM duty cycle. On irradiation  $1000\text{W}/\text{m}^2$ , P&O method generates a duty cycle of 0.502 while Incremental Conductance method by 0.515. Duty cycle will be changed to follow changes in solar irradiation so that output voltage of buck boost converter remains on MPP point. Tracking time of P&O methods was recorded 0.001s while IC methods a slightly slower which is 0.005s. However the IC algorithm had a faster settling time at 0.002s. IC method also reduced the oscillation around MPP point. Using MPPT with IC method increases output power of system. In the solar irradiation of  $800\text{W}/\text{m}^2$ , output power of system without MPPT of 7.5W while it uses MPPT with IC method can increasing until 16W.

## 6. Conclusion

This research was targeted to analyze MPPT implementation on buck-boost converter by using Incremental Conductance method. The performance was compared to P&O algorithm. PV system, MPPT and Buck-Boost converter were simulated on Matlab Simulink. The simulation result shown the IC method had a better performance when it compared to P&O method. The IC method also successfully suppressed the oscillation around MPP point but the drawback is it had a slower tracking time. The tracking time can be improved by adjusting the increment/decrement step of duty cycle. The increment/decrement step also could be adaptively changed to achieve a better time response.

## Acknowledgements

The authors would like to thank you to the Indonesian Department of Education and State Polytechnic of Malang which sponsored this research by using National Research Competition 2014 funding scheme.

## References

- [1] Mirbagheri S.Z, Mekhilef S, Mirhassani S.M, "MPPT With Inc. Conductance Method Using Conventional Interleaved Boost Converter", *Energy Procedia* 42,2013.
- [2] Ayvazyan GY dkk, "Maximum Power Operation Of PV System Using Fuzzy Logic Control", *Armenian Journal of Physics*, Volume 1, 2008.
- [3] Kumar Yadav P, Thirumaligh S, Haritha G, "Comparison of MPPT Algorithm For DC-DC Converter Based PV System", *International Journal of Advances Research in Electrical, Electronics and Instrumentation Engineering* Vol 1 Issue 1,2012.
- [4] M. Rifa'i&Ratnalka P, "Pemodelandan Analisis Panel Photovoltaik", *Conference Informatic, Telecommunications Electrical Engineering*. UGM Yogyakarta, 2012.
- [5] Ratnalka P & M. Rifa'I, "Maximum Power Point Tracking Control For Photovoltaic Using Neural Fuzzy", *International journal of Computer and Electrical Engineering* Vol.4 No. 1, 2011.
- [6] Suwannatrai P, Liutanakul P, Wipasuramont, "Maximum power Point Tracking by Incremental Conductance Method For Photovoltaic System With Phase Shifted Full Bridge dc-dc Converter", *The 8th Electrical Engineering Electronics, Computer, Telecommunications and Information Technology (ECTI) Association of Thailand-Conference*, 2011.
- [7] Roshan Rajiv, YadavYatendra, S Umashankar, DP Kothari, "Modeling and Simulation of Incremental Conductance MPPT Algorithm Based Solar Photovoltaic System Using CUK Converter", *Energy Efficient Technology For Sustainability (ICEETS)*, *International Conference on*, 2013.
- [8] Qin Shihong, Wang Min, Chen T, Yao X, "Comparative Analysis of Incremental Conductance and Perturb -and-Observation Methods to Implement MPPT in Photovoltaic System", *Electrical and Control Engineering (ICECE)*, *International Conference on*, 2011.
- [9] Zhou Xuesong, DaichunSongg, Youjie Ma, Deshu Cheng, "The Simulation and Design for MPPT of PV System Based on Incremental Conductance Method", *WASE International Conference on Information Engineering*, 2010.
- [10] Mark Tung, Hu Patrick, Nair Nirmal, "Evaluation of Microcontroller Based Maximum Power Point Tracking Methods Using dSPACE Platform", *Australian University Power Engineering Conference*, 2006.
- [11] Challa DTR, Raghavendar I, "Implementation of Incremental Conductance MPPT With Direct Control Method Using Cuk Converter", *International Journal of Modern Engineering Research* Vol.2 Issue 6, 2012.
- [12] Balamurugan T, Manoharan S. 2012. Fuzzy Controller Design Using Soft Switching Boost Converter For MPPT in Hybrid System. *International Journal of Soft Computing and Engineering*.
- [13] VinodhkumarG, Reena J, Sasikumar M. 2012. Performance Enhancement in PV System Using Intelligent Controller Based MPPT Controller. *IOSR Journal of Engineering* Vol 2 Issue 2.