

Note

## A small aperiodic set of Wang tiles

Jarkko Kari\*

*Department of Computer Science, University of Iowa, MacLean Hall, Iowa City, Iowa 52242-1419, USA*

Received 3 January 1995

---

### Abstract

A new aperiodic tile set containing only 14 Wang tiles is presented. The construction is based on Mealy machines that multiply Beatty sequences of real numbers by rational constants.

---

### 1. Introduction

*Wang tiles* are unit square tiles with colored edges. A *tile set* is a finite set of Wang tiles. We consider *tilings* of the infinite Euclidean plane using arbitrarily many copies of the tiles in the given tile set. Tiles are placed on the integer lattice points of the plane with their edges oriented horizontally and vertically. The tiles may not be rotated. The tiling is *valid* if everywhere the contiguous edges have the same color.

Let  $T$  be a finite tile set, and  $f: \mathbb{Z}^2 \rightarrow T$  a tiling. Tiling  $f$  is *periodic* with period  $(a, b) \in \mathbb{Z}^2 \setminus \{(0, 0)\}$  iff  $f(x, y) = f(x + a, y + b)$  for every  $(x, y) \in \mathbb{Z}^2$ . If there exists a periodic valid tiling with tiles of  $T$ , then there exists a *doubly periodic* valid tiling, i.e. a tiling  $f$  such that, for some  $a, b > 0$ ,  $f(x, y) = f(x + a, y) = f(x, y + b)$  for all  $(x, y) \in \mathbb{Z}^2$ . A tile set  $T$  is called *aperiodic* iff (i) there exists a valid tiling, and (ii) there does not exist any periodic valid tilings.

Chapters 10 and 11 of [3] contain an excellent overview of what is known about aperiodic tile sets. Their existence was proved in a remarkable work by Berger [2] in 1966. The tile set he constructed contains over 20 000 tiles, and he used them to prove that it is undecidable whether a given tile set admits valid tilings. Since then several aperiodic sets have been found, including the smallest known aperiodic tile set due to R. Amman that contains only 16 tiles. In the present work we reduce this number even further by presenting an aperiodic set of 14 Wang tiles. It remains an interesting open problem whether there are even smaller aperiodic sets.

---

\* E-mail: jkkari@cs.uiowa.edu.

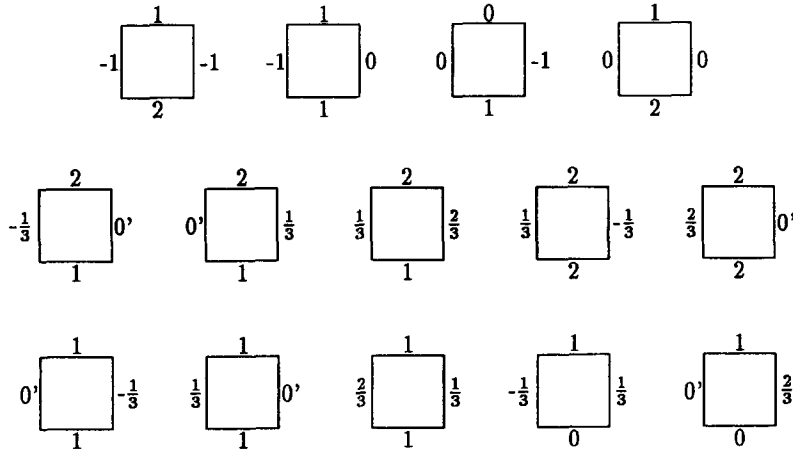
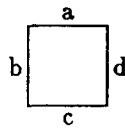

Fig. 1. Aperiodic set of 14 Wang tiles.

**2. The tiles**

Our set  $T$  of 14 tiles is shown in Fig. 1. The colors are rational numbers — number 0 may also be marked with a prime. Let us divide  $T$  into two disjoint sets  $T_2$  and  $T_{2/3}$ , where  $T_2$  contains the four tiles on the first row of Fig. 1 and  $T_{2/3}$  the remaining ten tiles. The colors of the vertical edges are different in the two sets, so in every valid tiling all tiles on the same row must belong to the same set  $T_q$ .

We say that tile



multiplies by  $q$  if  $aq + b = c + d$ . In other words, the tile multiplies the number on its upper edge by  $q$ , adds the ‘carry’ from the left edge, and splits the result between the lower edge and the ‘carry’ to the right. Clearly, the tiles in  $T_2$  multiply by 2, and the tiles in  $T_{2/3}$  by  $\frac{2}{3}$ . (The vertical color  $0'$  in  $T_{2/3}$  is interpreted as 0; the prime is used to distinguish it from the color 0 used in  $T_2$ .)

**Proposition 1.** *The tile set  $T$  does not admit a periodic tiling.*

**Proof.** Assume that  $f: \mathbb{Z}^2 \rightarrow T$  is a doubly periodic tiling with horizontal period  $a$  and vertical period  $b$ . For  $i \in \mathbb{Z}$ , let  $n_i$  denote the sum of colors on the upper edges of tiles  $f(1, i), f(2, i), \dots, f(a, i)$ . Because the tiling is horizontally periodic with period  $a$ , the ‘carries’ on the left edge of  $f(1, i)$  and the right edge of  $f(a, i)$  are equal. Therefore  $n_{i+1} = q_i n_i$ , where  $q_i = 2$  if tiles of  $T_2$  are used on row  $i$  and  $q_i = \frac{2}{3}$  if tiles of  $T_{2/3}$  are used.

Because the vertical period of tiling  $f$  is  $b$ ,

$$n_1 = n_{b+1} = q_1 q_2 \dots q_b \cdot n_1,$$

and because two tiles with 0's on their upper edges cannot be next to each other,  $n_1 \neq 0$ . So  $q_1 q_2 \dots q_b = 1$ . This contradicts the fact that no non-empty product of 2's and  $\frac{2}{3}$ 's can be 1.  $\square$

To show that  $T$  is aperiodic one has to demonstrate the existence of valid tilings. We do it in the next section by showing that the tiles can be used to multiply balanced representations of real numbers by 2 and  $\frac{2}{3}$ . This shows that there are in fact uncountably many valid tilings.

Any finite set of Wang tiles may be interpreted as a Mealy machine without initial and final states. A Mealy machine  $M$  is a labeled directed graph whose nodes are called *states* and edges are called *transitions*. The transitions are labeled by pairs  $a/b$  of letters. The first letter  $a$  is the input symbol and the second letter  $b$  the output symbol. Machine  $M$  computes a relation  $\rho(M)$  between bi-infinite sequences of letters. A bi-infinite sequence  $x$  over set  $S$  is a function  $x: \mathbb{Z} \rightarrow S$ . We will abbreviate  $x(i)$  by  $x_i$ . Bi-infinite sequences  $x$  and  $y$  over input and output alphabets, respectively, are in relation  $\rho(M)$  if and only if there is a bi-infinite sequence  $s$  of states of  $M$  such that, for every  $i \in \mathbb{Z}$ , there is a transition from  $s_{i-1}$  to  $s_i$  labeled by  $x_i/y_i$ .

The states of the Mealy machine corresponding to a given tile set are the colors of vertical edges. The colors of horizontal edges are the input and output symbols. There is a transition from state  $s$  to state  $t$  with label  $a/b$  iff there is a tile whose left, right, upper and lower edges are colored by  $s, t, a$  and  $b$ , respectively. Obviously, bi-infinite sequences  $x$  and  $y$  are in the relation  $\rho(M)$  iff there exists a row of tiles, with matching vertical edges, whose upper edges form sequence  $x$  and lower edges sequence  $y$ . So there is a one-to-one correspondence between valid tilings of the plane, and bi-infinite iterations of the Mealy machine on bi-infinite sequences.

The Mealy machine  $M$  corresponding to our aperiodic tile set is shown in Fig. 2. It consists of two disjoint components  $M_2$  and  $M_{2/3}$  corresponding to subsets  $T_2$  and  $T_{2/3}$ .

### 3. Beatty sequences

For an arbitrary real number  $r$  we denote by  $\lfloor r \rfloor$  the integral part of  $r$ , i.e. the largest integer that is not greater than  $r$ , and by  $\{r\}$  the fractional part  $r - \lfloor r \rfloor$ . In proving that our tile set can be used to tile the plane we use *Beatty sequences* of numbers. Given a real number  $\alpha$ , its bi-infinite Beatty sequence is the integer sequence  $A(\alpha)$  consisting of the integral parts of the multiples of  $\alpha$ . In other words, for all  $i \in \mathbb{Z}$ ,

$$A(\alpha)_i = \lfloor i \cdot \alpha \rfloor.$$

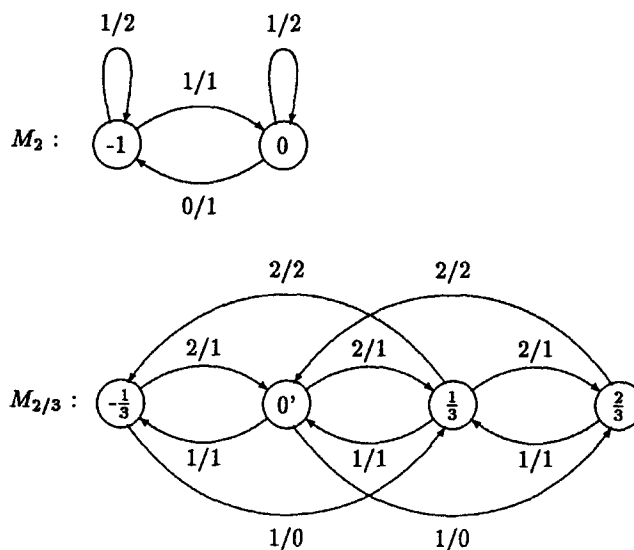

Fig. 2. Mealy machine corresponding to the aperiodic tile set.

Beatty sequences were introduced by Beatty [1] in 1926. He proved that, for any positive irrational numbers  $\alpha$  and  $\beta$  satisfying  $\alpha^{-1} + \beta^{-1} = 1$ , every integer — except  $-1$  and  $0$  — appears in exactly one of the Beatty sequences  $A(\alpha)$  and  $A(\beta)$ . (Because the only multiples of  $\alpha$  and  $\beta$  in the interval  $[-1, 1]$  are  $0 \cdot \alpha$  and  $0 \cdot \beta$ , number  $0$  appears in both Beatty sequences and number  $-1$  in neither of them.)

We use sequences obtained by computing the differences of consecutive elements of Beatty sequences. Define, for every  $i \in \mathbb{Z}$ ,

$$B(\alpha)_i = A(\alpha)_i - A(\alpha)_{i-1}.$$

The bi-infinite sequence  $B(\alpha)_i$  will be called the *balanced* representation of  $\alpha$ . The balanced representations consist of at most two different numbers: If  $k \leq \alpha \leq k + 1$  then  $B(\alpha)$  is a sequence of  $k$ 's and  $(k + 1)$ 's. Moreover, the averages over finite subsequences approach  $\alpha$  as the lengths of the subsequences increase. In fact, the averages are as close to  $\alpha$  as they can be: The difference between  $l \cdot \alpha$  and the sum of any  $l$  consecutive elements of  $B(\alpha)$  is always smaller than one.

For a given positive rational number  $q = n/m$ , let us construct a Mealy machine  $M_q$  that multiplies balanced representations  $B(\alpha)$  of real numbers by  $q$ . The states of  $M_q$  will represent all possible values of  $q \lfloor r \rfloor - \lfloor qr \rfloor$  for  $r \in \mathbb{R}$ . Because

$$q \lfloor r \rfloor - 1 \leq qr - 1 < \lfloor qr \rfloor \leq qr < q(\lfloor r \rfloor + 1),$$

we have

$$-q < q \lfloor r \rfloor - \lfloor qr \rfloor < 1.$$

Because the possible values of  $q \lfloor r \rfloor - \lfloor qr \rfloor$  are multiples of  $1/m$ , they are among the  $n + m - 1$  elements of

$$S = \left\{ -\frac{n-1}{m}, -\frac{n-2}{m}, \dots, \frac{m-2}{m}, \frac{m-1}{m} \right\}.$$

$S$  is the state set of  $M_q$ .

The transitions of  $M_q$  are constructed as follows: There is a transition from state  $s \in S$  with input symbol  $a$  and output symbol  $b$  into state  $s + qa - b$ , if such a state exists. If there is no state  $s + qa - b$  in  $S$  then no transition from  $s$  with label  $a/b$  is needed. After reading input  $\dots B(\alpha)_{i-2} B(\alpha)_{i-1}$  and producing output  $\dots B(q\alpha)_{i-2} B(q\alpha)_{i-1}$ , the machine is in state

$$s_{i-1} = qA(\alpha)_{i-1} - A(q\alpha)_{i-1} \in S.$$

On the next input symbol  $B(\alpha)_i$  the machine outputs  $B(q\alpha)_i$  and moves to state

$$\begin{aligned} s_{i-1} + qB(\alpha)_i - B(q\alpha)_i &= qA(\alpha)_{i-1} + qB(\alpha)_i - (A(q\alpha)_{i-1} + B(q\alpha)_i) \\ &= qA(\alpha)_i - A(q\alpha)_i \\ &= s_i \in S. \end{aligned}$$

The Mealy machine was constructed in such a way that the transition is possible. This shows that if the balanced representation  $B(\alpha)$  is a sequence of input letters and  $B(q\alpha)$  is over output letters, then  $B(\alpha)$  and  $B(q\alpha)$  are in relation  $\rho(M_q)$ .

Mealy machine  $M_2$  in Fig. 2 is constructed in this fashion for multiplying by 2, using input symbols  $\{0, 1\}$  and output symbols  $\{1, 2\}$ . This means that  $B(\alpha)$  and  $B(2\alpha)$  are in relation  $\rho(M_2)$  for all real numbers  $\alpha$  satisfying  $0 \leq \alpha \leq 1$  and  $1 \leq 2\alpha \leq 2$ , that is, for all  $\alpha \in [\frac{1}{2}, 1]$ . Similarly,  $M_{2/3}$  is constructed for input symbols  $\{1, 2\}$  and output symbols  $\{0, 1, 2\}$ , so that  $B(\alpha)$  and  $B(\frac{2}{3}\alpha)$  are in relation  $\rho(M_{2/3})$  for all  $\alpha \in [1, 2]$ .

**Proposition 2.** *Tile set  $T$  admits uncountably many valid tilings of the plane.*

**Proof.** From the input sequence  $B(\alpha)$  for any  $\alpha \in [\frac{1}{2}, 2]$ , the Mealy machine  $M$  computes output  $B(2\alpha)$  if  $\alpha \in [\frac{1}{2}, 1]$ , and  $B(\frac{2}{3}\alpha)$  if  $\alpha \in [1, 2]$ . The machine  $M$  may be applied again using the previous output as input, and this may be repeated arbitrarily many times.

On the other hand, if  $\alpha \in [\frac{2}{3}, 2]$  there is input  $B(\frac{1}{2}\alpha)$  or  $B(\frac{3}{2}\alpha)$  that is in relation  $\rho(M)$  with  $B(\alpha)$ . Input sequence  $B(\frac{1}{2}\alpha)$  is used if  $\alpha \geq \frac{4}{3}$ , and  $B(\frac{3}{2}\alpha)$  is used if  $\alpha \leq \frac{4}{3}$ . This can be repeated arbitrarily many times, so  $M$  can be iterated also backwards. This shows that there are bi-infinite iterations of  $M$  on bi-infinite sequences  $B(\alpha)$ ,  $\alpha \in [\frac{2}{3}, 2]$ , which proves the proposition.  $\square$

Propositions 1 and 2 prove that  $T$  is aperiodic.

**References**

- [1] S. Beatty, Problem 3173, *Am. Math. Monthly* 33 (1926) 159; solutions in 34 (1927) 159.
- [2] R. Berger, The undecidability of the domino problem, *Mem. Amer. Math. Soc.* 66 (1966).
- [3] B. Grünbaum and G.C. Shephard, *Tilings and Patterns* (W.H. Freeman and Company, New York, 1987).