



DESIGN REQUIREMENTS

UNIVERSITY OF UTAH SUPPLEMENT

March 29, 2022

The University of Utah
FACILITIES MANAGEMENT
V. Randall Turpin University Services Building
1795 E. South Campus Drive, Room 201
Salt Lake City, Utah 84112-9403

TABLE OF CONTENTS

1.0	GENERAL.....	4
1.1	General	4
1.2	Procedure	4
1.3	Hierarchy of Requirements	4
1.4	Changes and Additions to Design Requirements	4
1.5	University Approved Equal	4
2.0	CODES / LAWS / RULES AND REGULATORY REQUIREMENTS	5
2.1	General	5
2.2	DFCM Requirements	5
2.3	Building Code Commission	5
2.4	Fire Prevention Board.....	5
2.5	Accessibility Code	5
2.6	Labor Commission	5
2.7	Department of Health	5
2.8	Department of Environmental Quality.....	5
2.9	County Health Department	5
2.10	Department of Commerce	5
3.0	UNIVERSITY REQUIREMENTS	7
3.1	General	7
3.2	Civil	12
3.3	Architectural.....	24
3.4	Structural.....	53
3.5	Electrical	53
3.6	Mechanical – General.....	97
3.7	Plumbing.....	102
3.8	HVAC Systems.....	105
3.9	Automatic Sprinkler Systems.....	114
3.10	Components	115
3.11	Communications and Security Wiring Systems.....	115
4.0	LANDSCAPE AND IRRIGATION STANDARDS	151
4.1	General	150
4.2	Water Allowance	153
4.3	Landscape Design Standards	153
4.4	Irrigation Design Standards	176
5.0	HIGH PERFORMANCE BUILDING SYSTEMS	189
5.1	LEED Requirements	189
5.2	University’s Measurement and Verification Plan.....	193
6.0	SUMMARY OF PRODUCTS AND VENDORS	196
6.1	General	196
6.2	List of University Approved Products	196

Page left intentionally blank

1.0 GENERAL

1.1 General

- A. The latest edition of the *DFCM Design Requirements* and the *University Design Requirements* supplement shall be followed on all University of Utah projects. This document accepts the *DFCM Design Requirements* as the University's own, and supplements it with additional requirements. These documents together form the core standard for architectural and engineering services provided on University projects.
- B. The Architect and/or Engineer (herein after referred to as "A/E") is to adhere to both the *DFCM* and *University Design Requirements* on all projects for the University whether the contract originates from DFCM or from the University of Utah.
 - a. The University's supplement has additional sections, headings and subheadings to accommodate additional requirements that are unique to the University.

1.2 Procedure

- A. Complete the 'University of Utah Design Standards Change Request Form' to make recommendations for additions, deletions and changes to the *University Design Requirements*. All modifications shall require approval by the University's Design Standards Committee.
- B. Complete the 'University of Utah Design Standards Project Variance Request Form' for approval to vary from these *Design Requirements* based upon specific project needs. The A/E shall document why the current design requirement cannot be met, including valid justifications and recommended solutions. All variance requests require approval by the University's Design Standards Committee.

1.3 Hierarchy of Requirements

- A. For DFCM managed projects, the State Building Official with the approval of the Director of DFCM and/or the State Fire Marshal shall have authority to grant modifications. DFCM modifications granted by the State Building Official shall be documented in as required by DFCM.
- B. For University managed projects, the University Building Official and/or the University Fire Marshal shall have the authority to grant modifications. Any modifications granted by the University shall be documented as required by 1.4 below.

1.4 Changes and Additions to Design Requirements

1.5 University Approved Equal

- A. The materials, products, and equipment described in the *University Design Requirements* establish the standard of required function, dimension, appearance, durability, warranty, maintainability and quality to be met by any proposed alternative. The A/E may submit an approved equal product for consideration through the University Project Manager if they believe that a product meets or exceeds the current *University Design Requirements*. Refer to [6.0 for University Approved Products](#).
- B. The Design Professional shall submit proposed approved equal products to the University Project Manager for review and approval by the Design Standards Committee as a Project Variance Request prior to final inclusion in contract documents. The approved equal submittal shall include an analysis and recommendation by the design professional.

2.0 CODES / LAWS / RULES AND REGULATORY REQUIREMENTS

The DFCM Design Requirements shall be followed on all University projects, along with the additional University requirements detailed below.

- 2.1 General
- 2.2 DFCM Requirements
 - A.
- 2.3 Building Code Commission
 - A. Enforcement is the responsibility of the University's Building Official for University managed projects.
- 2.4 Fire Prevention Board
 - A. The A/E is to coordinate with the University Fire Marshal.
- 2.5 Accessibility Code
 - A. No additional University requirements.
- 2.6 Labor Commission
 - A. No additional University requirements.
- 2.7 Department of Health
 - A. No additional University requirements.
- 2.8 Department of Environmental Quality
 - A. In addition to the DFCM requirements, the A/E shall coordinate with the University's Occupational and Environmental Health & Safety Office for specific University requirements.
- 2.9 County Health Department
 - A. No additional University requirements.
- 2.10 Department of Commerce
 - A. No additional University requirements.

3.0 UNIVERSITY REQUIREMENTS

The DFCM Design Requirements shall be followed on all University projects, along with the additional University requirements detailed below.

3.1 General

A. Enhanced Accessibility

- (1) University of Utah projects managed either by DFCM or the University of Utah shall include in the project's scope of work the construction of primary or secondary accessible paths of travel, or improvements to existing primary/secondary accessible paths of travel. The intent of this requirement is to enhance and provide consistency with the network of accessible pathways throughout the University campus or University owned properties. This requirement shall apply to new buildings, additions to existing buildings, site landscaping, civil or utility infrastructure improvements which interface with or impact the primary and secondary accessible routes as shown in the Accessible Paths of Travel Study. The University Project Manager or Project Planner shall determine the extent of this requirement during the planning or programming phase. The A/E shall provide design solutions as guided by the Accessible Paths of Travel Study a copy of this Study will be provided by the University Project Manager or Planner.

B. Energy Efficient Products

- (1) Many buildings on campus have been retrofitted with energy efficient equipment as part of an energy management plan. When remodeling any building, the energy efficiency and operating characteristics of existing and new equipment shall not be diminished by the building revisions.

C. Energy Design Standards

- (1) The DFCM and University High Performance Building Systems (HPBS) apply to all design and construction projects. The University also has additional LEED requirements detailed in [5.1](#).

D. Hazardous Materials

- (1) A/E shall coordinate with University Project Manager regarding hazardous materials on site.

E. Vibration

- (1) No additional University design requirements.

F. Utah Space Standards

- (1) No additional University design requirements.

G. Infrastructure Flexibility

- (1) No additional University design requirements.

H. Standard Building Plaque

- (1) A/E shall coordinate with University Project Manager for specific University design.

I. Construction Coordination

(1) Work Restrictions

- a. The A/E is to work with Facilities Management through the University Project Manager to establish the limits of construction during the design development stage to include the area which is affected by the work. If possible, this is to include areas affected by the shutdown of the landscape irrigation.

(2) Traffic Management Plan

- a. Traffic control is a major concern on campus. Consult with Facilities Management through the University Project Manager to identify procedures to be used in a traffic management plan for the project. Describe access routes to the job site through the campus for concrete trucks, delivery trucks and other vehicles concerned with the project. The approved plan should be detailed for the Contractor and included as part of the project documents.
- (3) Parking Requirements for Construction
 - a. Project Parking Plan shall be developed to establish the parking impact during and after a construction Project. This Plan is to be done during the design process to provide direction in the contract documents that will inform the bidding and successful contractor what parking will be available to the project during construction. This plan is to be developed jointly by the Design Team, University Project Manager, University Project Planner, and University Commuter Services. Once prepared, the Parking Plan form is to be included with the design documents when they are submitted for plan review, preferably at DD review, but no later than CD. The Plan shall be approved during the plan review process and the information then included in the bid contract documents.
- (4) Contractor's Use of Building Equipment
 - a. Include provisions for the Contractor to use equipment such as electric motors, blowers, heat exchangers, filters, lighting fixtures, etc., with the written permission of the University. As each piece of equipment is used (such as electric motors and blowers), require the Contractor to follow maintenance procedures approved by the manufacturer. Require the Contractor to maintain a careful record of the time used, maintenance procedures followed, and any difficulties experienced with the equipment. These contractors' records on the equipment are to be submitted to the University upon acceptance.
 - b. For extended projects, require the Contractor to replace used expendables of the equipment with new replacements which meet equipment and project specifications (i.e., belts, filter media, fluorescent lamps, bearings, etc.). Require these items to be inspected just prior to acceptance. Any excessive wear noted during the inspection shall require replacement. Require the guarantee period for equipment to begin with Substantial Completion acceptance by the University. Coordinate these items with Facilities Management (especially Facility Operations) through the University Project Manager.
- (5) Temporary Facilities for Construction
 - a. Include provisions for a construction area fence and gate at least 6-ft high. Refer to [4.3 F](#) for chain link fence requirements.
 - b. Require the Contractor to provide dust and noise barriers in all remodeling areas.
 - c. Temporary Project Sign requirements should be coordinated with the University Project Manager.
 - d. Where construction sites interrupt existing pedestrian pathways (determined by consultation with Facilities Management, and the Occupational and Environmental Health & Safety officials through the University Project Manager), such pathways shall be replaced with temporary walks to circumvent the interrupted areas. Damage to existing walkways shall be restored at the completion of construction at Contractor's expense whether inside or outside (adjacent to) the construction site.

- e. The A/E is to specify and delineate requirements for the Contractor to provide adequate outdoor lighting along walkways and around the perimeter of construction site. Such lighting shall be operational for all hours of darkness during extent of construction.
- J. Emergency Phones
- (1) The decision to install emergency phones as part of a construction project will be by the University. The University Project Manager will obtain University approval to include E-phones in the project design; and, obtain approved equipment specifications through the Managing Director of Occupational and Environmental Health & Safety and Emergency Management, and the University Chief of Police.
 - (2) Facilities management, through the University Project Manager, will provide to the A/E:
 - a. Guide specifications for approved emergency phone devices.
 - b. Specific E-phone functionality and operational characteristics required by University Public Safety.
 - c. Contractor instructions for equipment connections.
- K. Demolition – Expectations of the A/E's Design
- (1) Prior to Design Development Submittal
 - a. During the design of the project (before submission of the design development documents for review), the A/E, together with its sub consultants, shall identify furnishings, accessories, equipment, material, systems, etc. which will be affected or removed by demolition.
 - b. The A/E and sub consultants as appropriate shall meet with the University Project Manager, representatives from Facility Operations, and a representative of University Surplus and Salvage. This focus of this meeting will be to determine final ownership of all of removed items; and, for those items returned to the University, any required preparation, delivery and transfer instructions.
 - i. Items which will remain the property of the University shall be clearly identified and listed for inclusion in the Contract Documents.
 - (a) Generally, all fire alarm components will remain the property of the University. The disposition of removed fire alarm wiring and conduit will be considered on a project by project basis.
 - ii. Include instructions to the Contractor for preparations and delivery of each of the removed items to the University (safety preparations, coiling, packaging, palletizing, cleaning, prior notification, delivery location, etc.).
 - c. The A/E may be asked to tag or otherwise identify specific items at the site before demolition to aid the Contractor's awareness and protection of University property.
 - d. Remaining items which will become the property of the Contractor shall be included in the Contract Documents, allowing the Contractor to include salvage value in the bid. This may be a general summarization of all remaining demolition, or specific items or systems.
 - i. Include both declarations in the design development review documents as they are intended to appear in the bidding documents.
 - ii. Include salvage value in the detailed cost estimate.
 - (2) Site Visit Reports
 - a. Include the disposition of items which are identified to be returned to the University in site visit reports.

- L. Parking and Service Access
 - (1) Provide service area for a minimum of two trucks adjacent to each building and provide space for trash containers which will be picked up by a truck lift.
 - (2) The University uses the dumpster system of trash removal. This consists of metal containers placed outside each building (one per building is usually required) in which the trash is deposited.
 - (3) All dumpsters are to be enclosed in an appropriate enclosure and screening device appropriately located on the site. The design for the approach to the enclosure shall be reviewed with Facilities Management prior to going to bid.
- M. University Hospitals, Clinics and the School of Medicine – Special Design Requirements
 - (1) University of Utah Health Care (UUHC) operates University hospitals, clinics, and other facilities throughout the State.
 - (2) UUHC Department of Facilities & Engineering (Hospital F&E) manages some projects under delegation from U of U Facilities Management.
 - (3) All requirements described in the DFCM Design Manual and University of Utah Supplement (Programming Standards, Design Process, and Design Requirements) apply to all UUHC projects. The UUHC Hospital Design Standards and the UUHC Contractor Handbook supplement, but do not replace A/E requirements for design described in the DFCM Design Manual and University of Utah Supplement.
 - (4) UUHC Hospital Design Standards
 - a. Special design requirements for UUHC projects are described herein below and in the UUHC Hospital Design Standards. The UUHC document is available from Hospital F&E through the University Project Manager. UUHC standards may be applicable to the Project for hospital grade materials and finishes, and/or non-patient care construction requirements. Where UUHC Hospital Design Standards are silent on any design issue, the instructions provided in the DFCM Design Manual and this Supplement shall apply.
 - (5) UUHC Contractor Handbook
 - a. Special construction requirements for UUHC projects are described in the Contractor Handbook for UUHC Construction Projects (or “Handbook”) available on the University’s Facilities Management web site. The Handbook shall be included in the A/E’s project specifications, either in print or by reference. The A/E’s specifications shall require the Contractor to print the Handbook for use during construction.
 - b. Parking and staging areas
 - i. The A/E shall coordinate with the FM Project Manager / Hospital F&E Project Supervisor to determine appropriate staging and parking areas for the Project, and include this information in the Project design drawings or specifications.
 - ii. Include a warning that emergency access to UUHC facilities, and patient, staff, fire lane, and handicapped parking is critically important to UUHC operations, and must not be impeded, even temporarily.
 - c. Stair / Elevator Access
 - i. The A/E shall coordinate with the FM Project Manager / Hospital F&E Project Supervisor to identify appropriate routes for Contractor access to the work site,
 - including selected stairwells and elevators for the transport of materials. This information shall be included in the Project design drawings or

- specifications and describe or show any areas to be avoided by construction workers.
- d. Special Working Hours
 - i. The A/E shall coordinate with the FM Project Manager / Hospital F&E Project Supervisor to determine the need for special working hours, and certain hours when noise transmission must be limited. Any special requirements must be included in the Project design drawings or specifications.
 - e. Restroom Limitations
 - i. The A/E shall coordinate with the FM Project Manager / Hospital F&E Project Supervisor to determine the limitations to be imposed on the use of restrooms in the facility. Unless approved otherwise, the A/E shall specify that the Contractor shall provide hand washing and restroom facilities for its personnel, separate from UUHC restrooms.
 - f. Dumpster Locations
 - i. The A/E shall coordinate with the FM Project Manager / Hospital F&E Project Supervisor to determine approved locations for the Contractor's dumpsters/trash receptacles, and show these on the Project drawings.
 - g. Requirements for Interim Life Safety Measures (ILSM)
 - i. The A/E shall coordinate with the FM Project Manager / Hospital F&E Project Supervisor for a site review meeting held with the Hospital Fire Marshal, the infection control team, and any other applicable safety team to assess the proposed construction to identify any possible compromise to the building's life safety system.
 - ii. The A/E shall keep accurate minutes of the meeting. Documents provided by UUHC life safety staff for use on the Project shall be combined with applicable items in the A/E minutes to form an "ILSM Project Plan." A specific form or format will be required by UUHC.
 - iii. The ILSM Project Plan must include the Statement of Conditions fire drawings, including requirements for patching walls, available from the Hospital Fire Marshal or the Hospital F&E Project Supervisor.
 - iv. Insert the ILSM Project Plan, the required ILSM Form, and all terms of the ILSM plan in the Project specifications, including but not limited to assessment summaries, expected UUHC monitoring, the maximum number of expected debrief meetings, any required documentation to be posted and/or kept in a Contractor's project file on site, any required Contractor reports with expected frequency, any other special procedures, etc.
 - h. Requirements for Infection Control Construction Risk Assessment
 - i. An Infection Control Construction Risk Assessment (ICRA) is generally required on all projects affecting or near patient areas. UUHC will initiate the ICRA for each applicable project, and the A/E shall apply the project's completed ICRA to the drawings and specifications, and require the Contractor to comply with ICRA safety measures and requirements.
 - ii. Include any other project specific requirements directed by the UUHC's safety team or infection control team (*e.g.*, assessment, documentation, monitoring, reports, special procedures, pressure / flow indicators, tacky mats, etc.).

- i. Dust, Vapor, Etc., Containment
 - i. The A/E shall coordinate with the FM Project Manager / Hospital F&E Project Supervisor to identify project requirements for the containment of dust, aerosol, fumes, vapors, etc. (e.g., any required approved plans, Contractor documentation, reports, etc.). Include any requirements in the Project specifications.
 - j. Materials & Equipment Specified for UUHC Projects
 - i. All materials/equipment specified must be U/L approved. Require independent testing lab sheets with the Contractor's submittal.
 - ii. For all hospital and clinic designs, material and equipment components are required to be Hospital Grade. Coordinate with the FM Project Manager / Hospital F&E Project Supervisor to determine if Hospital certification will be required.
 - iii. Coordinate with the FM Project Manager / Hospital F&E Project Supervisor to identify approved finish materials for the Project specifications.
 - iv. The design and resulting construction must meet federal/state/local and UUHC requirements.
 - v. Only non-asbestos containing materials may be specified.
- N. University of Utah Design Standards for Small Wireless Facilities
 - (1) The University of Utah Design Standards for Small Wireless Facilities dated August 29, 2018 is hereby incorporated into the University's Design Requirements. This document is available on the Planning, Design & Construction web site at: <https://pdc.utah.edu/campus-planning/>
- 3.2 Civil
- A. Paving
 - (1) Sidewalk Requirements
 - a. Sidewalks on campus shall be 8-ft wide (minimum). Central slab thickness shall be 6- in thick, and grow to 8-in thick at both edges. The width of the thicker edge on each side of the sidewalk shall not be less than 6-in. Six inches from the sidewalk edge, the 8-in thick concrete shall taper approximately 45° from 8-in to the 6-in central slab thickness.
 - b. All sidewalks shall include polypropylene multifilament fiber reinforcement.
 - B. Site Utilities
 - (1) Campus Utility Systems
 - a. Facilities Management owns and operates multiple utility systems on Campus. The following requirements herein apply to all utilities on Campus. Specific design requirements can be found in the individual sections.
 - i. Water Distribution System, see [3.2 C.](#)
 - ii. Storm Drain, see [3.2 D.](#)
 - iii. Sanitary Sewer, see [3.2 E.](#)
 - iv. Natural Gas, see [3.2 F.](#)
 - v. Electrical Distribution, see [3.5.](#)
 - vi. High Temperature Water, see [3.8 D.](#)
 - vii. Chilled Water, see [3.8 G.](#)
 - viii. Irrigation Water, see [4.4.](#)
 - ix. Communication Systems, [3.11](#)
 - b. The most recently published version of the American Public Works Association

(“APWA”) Standard Specifications and APWA Standard Plans, as currently adopted by the APWA Utah Chapter, may be used for the design and construction of campus utilities. While the APWA standards are to be closely followed, this University supplement contains additional or alternative requirements which shall be included in the A/E’s design. In the event of conflict, the DFCM and University Design Manual will govern.

(2) Utility Layout, Capacity, Connection Points

- a. Facilities Management through the University Project Manager will provide all utility information available concerning the project work and surroundings. The A/E shall evaluate the utility information available against the project needs.
- b. If exact elevations and locations are deemed necessary or desirable, the University will uncover the utilities and make the necessary surveys required (upon request from the A/E). Requests for this special information should be made to Facilities Management through the University Project Manager.
- c. Coordinate with Facilities Management through the University Project Manager concerning utility connection points, capacities, crossings, etc.
 - i. Computer models of campus utility systems shall be used to evaluate the impact of new systems on existing pipe sizes and capacities.
 - ii. The proposed system layout shall be optimized by model analysis. Consult with Facilities Management regarding the model software used for each utility.
 - iii. Submit the proposed system layout with a complete report, including calculations, to the University Project Manager for Facilities Management review. The A/E is responsible for the accuracy of the submittal and subsequent design. University approval of the submittal shall not be considered a verification of the data, nor verification of the workability of the proposed design.

(3) Utility Metering

- a. Construction Utilities
 - i. For non-State funded projects, specify construction utility metering per University meter specifications for water, electrical and natural gas (this does not include high temperature water which shall not be activated nor used until directed by the University). The Contractor will purchase the meters and either install them at locations directed by the University, or pay the University to install the meters. During construction, the Contractor will be invoiced for utilities used. This is only applicable to non-State funded projects where all the monies for construction come from University or donated sources.
- b. University Auxiliaries, Dining Facilities, State Supported O&M Facilities, etc.
 - i. Design the utilities such that water, natural gas, and electricity can be separately metered for auxiliary functions within a University building. Include overall building meters, as well as sub-meters for utilities used by the auxiliary function. Coordinate with the University Project Manager to determine which end user activities will require metering. Refer to DFCM 5.11 for metering requirements.

(4) Underground Utility Depth & Separation Standard

- a. The extension of buried utility systems on campus must conform to the University’s Utility Master Plan to maintain minimum depth of bury and

service clearances from underground structures and other utilities. Deviation from the master plan, as summarized in the following graphic, may only occur after review and approval from Facilities Management.

UTILITIES CORRIDOR OR ROADWAY X-SECTION

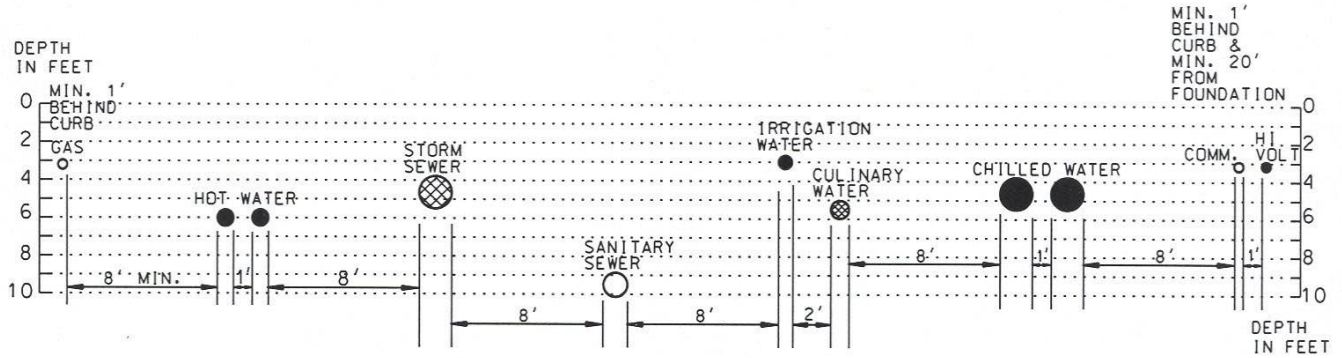

b. Easement Matrix for Existing Utilities

	HTW	CHILLED WATER	SAN. SEWER	STORM SEWER	WATER	GAS	POWER	COMM.
Minimum Depth	6'	4'	4'	4'	5'	3'	3'	3'
HTW								

	HTW	CHILLED WATER	SAN. SEWER	STORM SEWER	WATER	GAS	POWER	COMM.
Horizontal		10'	8'	8'	8'	6'	10'	10'
Vertical		10'	8'	8'	4'	6'	10'	10'
Chilled Water								
Horizontal	10'		8'	8'	8'	4'	8'	8'
Vertical	10'		3'	3'	3'	3'	3'	3'
Sanitary Sewer								
Horizontal	8'	8'		8'	10'	8'	8'	8'
Vertical	8'	3'		3'	3'	3'	3'	3'
Storm Sewer								
Horizontal	8'	8'	8'		8'	8'	8'	8'
Vertical	8'	3'	3'		3'	3'	3'	3'
Water								
Horizontal	8'	8'	8'	8'		8'	8'	8'

Vertical	4'	3'	3'	3'		3'	3'	3'
Gas								
Horizontal	6'	4'	8'	8'	8'		4'	4'
Vertical	6'	3'	3'	3'	3'		3'	3'
Power								
Horizontal	10'	8'	8'	8'	8'	4'		1'
Vertical	10'	3'	3'	3'	3'	3'		1'
Communications								
Horizontal	10'	8'	8'	8'	8'	4'	1'	
Vertical	10'	3'	3'	3'	3'	3'	1'	

(5) Utility Conflicts

- a. Where piping systems (i.e., sewer, water, irrigation, drainage, chilled water, etc.) will unavoidably cross structures (i.e., footings, walls, concrete ducts, tunnels, etc.) that are more than 4 feet wide and 5 or more feet deep; and, where direct access to the piping is limited and will not comply with OSHA trench standards, design the crossing with either a casing pipe that extends a minimum of 5 feet beyond the structure, or require a 20 foot (minimum) section of ductile iron pipe.
- b. See [3.8 D \(10\)](#) for special requirements at buried high temperature water (HTW) pipeline crossings. All utilities that cross or come within 5-ft horizontally of existing HTW must adhere to these special requirements.
- c. Any new above grade structure which will be located over any existing utility will require one of the following design options:
 - i. Relocate all utilities.
 - ii. Design a tunnel, chase way, pipe sleeve, or other suitable access for any utility being crossed by, or in the “near vicinity” of footings, retaining walls, staircases, or other concrete structures 8” thick or greater. “Near vicinity” means a lateral distance 1 ½ times the depth of the utility, from each side of the pipe or conduit. This will allow for excavations to comply with OSHA trench standards and eliminate the need for costly concrete demolition and replacement during utility failures. The chosen access must extend a minimum of 2’ past each side of the concrete structure.

(6) Utility Trenches

- a. All buried piping on Campus shall be inspected and surveyed by the University Surveyor prior to backfill.
- b. All underground pipelines shall be installed with magnetic plastic tape intended for direct bury, indicating the type of utility installed.
- c. Direct the Contractor to test and verify continuity of trace wire at the terminal end points prior to backfill. Also direct the Contractor to verify continuity again after backfill using the installed termination end points.
- d. The A/E shall show the location for each trace wire termination end point on the drawings.
 - i. Each trace wire is to be terminated in the interior of an irrigation valve box or manhole. If no suitable box or manhole exists at the termination point, instruct the Contractor to install an irrigation valve box for the trace wire.

- ii. Where underground pipe penetrates the building, the trace wire shall be terminated and secured in a box or manhole at the building exterior over the pipe penetration.
 - iii. Instruct the Contractor to complete each termination with a screwed connection to the side of the box or manhole, conveniently located for easy access. Excess wire may be coiled in place beyond the screwed attachment.
 - iv. As-built drawings shall show the actual location of each trace wire termination box or manhole, and note the pipe or conduit it serves.
 - (7) Salt Lake City Public Utilities
 - a. Any construction project (either new or remodel) which may affect Salt Lake City public utilities (sanitary sewer, storm drainage, or domestic water) by either feeding or using these utilities, must include coordination with Salt Lake City.
 - b. The A/E shall include in the specifications that the Contractor must provide all required information needed by Salt Lake City for review, and pay for and secure subsequent permits. The Contractor will then be required to conform to the jurisdiction's requirements for subsequent inspections and certificates of occupancy for the utility portion of the project.
- C. Water Distribution System
- (1) The source of the University's domestic water distribution system is Salt Lake City's water supply system.
 - (2) Water conservation measures are to be designed into, and implemented on all new construction or substantial remodeling projects. No project is to increase the quantity of water consumed; indeed, water consumption should decrease with the completion of each project.
 - (3) The building water supply for each project shall be taken from the University water distribution system. Fire flow tests are required for all new connections to water system.
 - (4) Hydraulically calculated fire suppression systems shall include a water system computer analysis to provide water pressure information.
 - (5) Water lines that are part of the campus water distribution system shall not be smaller than 8" in diameter. All lines supplying fire hydrants shall not be smaller than 6" in diameter.
 - (6) All tees, crosses and connections to water mains will have valves installed on all branches of piping.
 - (7) Minimum allowable cover over the top of pipe shall be 5'-0" to grade.
 - (8) All components of the water system shall be designed for a 200-psi working pressure.
 - (9) Specify blue PVC pipe per AWWA C900, DR-18 (235-psi) for sizes up to 12". Specify Class 52 ductile iron pipe with cement-mortar lining per AWWA C151, C104, and M41, with mechanical-joint fittings, per AWWA C110, for pipe sizes 14" and larger. Thrust blocks are required for all tees, valves, and bends in pipelines. See APWA Plan 561 and 562.
 - (10) PVC Pipe shall not be installed any closer than 10 feet from the outside building line.
 - (11) Distribution Valves shall be designed following guidelines in AWWA M44. Valves approved for use are gate, butterfly, pressure reducing, and check type.
 - (12) Any valve located more than 5 feet below grade shall be installed with a valve operator extension to allow operation from the surface with a 5-foot key.
 - (13) Isolation valves 12" and smaller shall be resilient-seated gate valves with nonrising stems in accordance with AWWA C509. Include valve box and 2" nuts for buried locations.
 - (14) Valves 14" and larger shall be butterfly valves per AWWA C504, Class 250B. Valves shall

be installed in a vault to allow access for maintenance and operations. Valve bodies shall be cast iron with mechanical-joint end connections. Valve shaft shall be AWWA C504, 18-8 type 304 Stainless Steel.

- (15) Air-Release, Air/Vacuum, and Combination Air Valves shall be per AWWA M51, and AWWA C512. Drawings should show: (1) Weld-O-Let (for steel pipe only); (2) threaded pipe outlet; (3) corporation cock; (4) gate valve; (5) nipple; and, (6) air release valve.
- (16) Pressure valves and check valves should be hydraulically operated globe valves, single seat construction, with replaceable stainless steel seat ring and a reversible inner valve disc. The valves shall have fully supported diaphragm operators.
- (17) All water mains require testing at 1.5 times the working pressure, or minimum 225 psi, for two hours in accordance with AWWA C600. Each test shall be witnessed by the A/E's professional engineer and the University's Water Master.
- (18) All new water lines shall be chlorinated to 50 ppm or higher and remain in the piping system for a 24-hour period. The heavily chlorinated water shall be flushed into a sanitary sewer (do not empty into a storm drain). The Salt Lake City Sewer Department shall be contacted prior to discharge. Salt Lake City shall be notified that highly chlorinated water is coming to them. Upon refilling the new domestic water system with clean potable water, two bacteriological samples, 24 hours apart, shall be analyzed. After the second sample comes back satisfactory, the system can be connected to the University's water system. All work shall be inspected by the University Water Master before being concealed or buried, and prior to start-up.

D. Storm Drain

- (1) Storm drainage calculations and drawings are to be submitted to the University Project Manager for review and approval. The submittal shall include the engineer's stamp and dated signature.
- (2) Storm Water Design Criteria
 - a. The storm water hydrology associated with new construction projects must mirror predevelopment hydrology of the previously undeveloped site; or, the design must improve the hydrology of a redeveloped site and reduce the discharge of storm water.
 - b. Projects which add impervious surfaces and storm water run-off must include storm-water control systems that will not increase flow into the University's (and consequently Salt Lake City's) storm-water system.
 - c. Provide on-site detention of storm water runoff to detain the 100 year, 24-hour storm, with 0.20 CFS/Acre run-off rate. Show calculations for detention volume requirement.
 - d. Provide on-site retainage for a 10 year 2-hour storm. If a 10 year 2-hour storm cannot be retained on the project site, design a modification to the University's storm water system which will accommodate an equivalent retention of the 10 year 2-hour storm. The modification could include bio retention (bioswale), pervious pavement, etc.
 - e. Runoff First to Pervious Surfaces or Landscape. The A/E's design shall direct the runoff onto pervious surfaces or landscaped areas prior to capture in a formal drainage system/structure to slow the time of concentration and increase water quality, and provide supplemental irrigation for landscaped areas.
 - f. Limit Impervious Surfaces. Every effort shall be made to minimize and disconnect impervious surfaces, slow the time of concentration, and improve water quality through the use of micro detention, bio retention (bioswale), etc. Convey runoff in surface conveyances to the greatest extent possible.

- g. The design shall incorporate both water quality and water quantity best management practices (BMP) and pollutant concentration calculations.
- (3) Sub-Drainage Systems
 - a. Approved sub-drainage systems are traditional building perimeter foundation and under floor drainage networks with gravity outfall systems.
 - b. Containment sub-drainage systems shall not be used (i.e., sumps, pits, detention, or other containment systems) without prior approval of Facilities Management through the University Project Manager.
 - (4) Concrete Pipe. Gravity flow storm drainage systems shall be reinforced concrete or non-reinforced concrete pipe. Non-reinforced concrete pipe shall only be used where load requirements permit.
 - (5) Minimum pipe size for storm drainage lines shall be 12" diameter.
 - (6) Minimum slope for storm drainage lines shall be 0.5%.
 - (7) Maximum distance between manholes or cleanouts shall not be greater than 300 feet.
 - (8) Manholes, catch basins or cleanouts shall be provided at every change in direction and every lateral tie-in point.
 - (9) Minimum allowable cover over the top of pipe shall be 3'-0" to grade.
 - (10) Camera Inspection. If the new storm drainage piping system fails during testing, require a camera inspection to identify the location and extent of failure. Failed or damaged portions of the new piping system shall be excavated and repaired. Require repeat test(s) until the system is proved.
- E. Sanitary Sewer
- (1) The University sanitary sewer system drains into Salt Lake City's sanitary sewer system; therefore, codes applicable to that system shall be followed. Refer to the 'Salt Lake City Building Design and Processes Manual'.
 - (2) The minimum lateral size outside a building shall be 6" diameter. The minimum main size shall be 8" diameter.
 - (3) All building laterals shall be tied in with a manhole, not a wye.
 - (4) The minimum design slope for a 6" lateral is 1.0%. The minimum design slope for an 8" main is 0.5%. The design for larger piping shall include 2.0 feet per second minimum velocity.
 - (5) The maximum distance between manholes shall not exceed 300 feet. Manholes shall be provided at every change of direction.
 - (6) New piping penetrations up to 12" diameter into existing manholes on campus are to be specified with an inside drop connection, similar to APWA Plan 433, Alternate 2. No excavated outside drop connections.
 - (7) The minimum allowable cover over the top of pipe shall be 4'-0" to grade.
 - (8) Buried sewer mains shall be bedded in sand and supported throughout its entire length. See APWA Plan 382.
 - (9) In addition to standard testing requirements, direct the Contractor to verify continuity of the piping with an air test between manholes. If the air test fails, require the Contractor to provide a camera inspection to identify the leak. Failed or damaged portions of the new sewer line shall be excavated and repaired. Require the Contractor to provide air testing until the piping is proved airtight.
- F. Natural Gas

- (1) Exterior buried gas lines shall follow Questar approved specifications for plastic pipe and shall be bedded in sand the entire length of the line.
- (2) No gas lines shall be run under-ground down-stream of the building regulator/meter set.
- (3) Exterior above ground gas lines 2-1/2" and larger shall be Schedule 40 forged black steel butt welded fittings; or, for 2" and smaller shall be 150 lb malleable iron with screwed fittings. Steel pipe shall have an approved protective coating. All outside above ground gas piping shall be painted with a protective gray paint.
- (4) When a gas pipe is run through a wall, the pipe shall be run through protective sleeve and sealed to prevent water from entering the building.
- (5) All gas piping shall be tested at 3 PSI for 10 minutes with no drop. A half-pound increment gauge shall be used. Where the supply is over 2 pounds, the test shall be at 1 ½ times the maximum working pressure. All tests shall be witnessed by the University of Utah Plumbing Shop or its' designee.
- (6) Natural gas systems on Campus are owned and operated by the University. Extensions or connections shall be coordinated with Questar when applicable and Facilities Management through the University Project Manager.
- (7) During design, notify Questar of any intended construction activity on their main lines, and continue coordination with Questar as the design progresses toward construction.
- (8) For buried natural gas piping, in addition to the trace wire, lines shall be installed with 2 feet of sand covering the pipe, and yellow warning tape 8" over the sand layer routed along the entire length of the pipe.
- (9) When work is required on any gas line, require the Contractor to submit for prior approval worker qualification sheets for each worker in accordance with Pipeline Safety Regulations Part 191 and Part 192, published by The Department of Transportation Research and Special Programs Administration, Office of Pipeline Safety, current edition.
- (10) Require the Contractor to submit qualification sheets to the A/E, then the A/E shall submit two sets to the University Project Manager, who will submit one set to the supervisor of the Plumbing Shop for review and approval.
- (11) Existing buried steel natural gas piping which will be replaced, modified, or removed as part of the project shall have a cathodic design with specifications for the application or removal and/or general upgrade of cathodic protection. Any modification or disturbance of steel piping is to include an upgrade of the local cathodic system and provisions for adequate protection to the remaining extended system. Once completed, the system is to be inspected and cathodic readings are to be written in a report to the University Project Manager who will relay the information to the University's Plumbing Shop. Likewise, the location of new anode bags and test stations shall be plotted and presented to the Plumbing Shop Supervisor.
- (12) If new plastic piping is to be routed under any road, the pipe must have a PVC pipe sleeve two pipe sizes larger than the gas line it will protect.

G. Storm Water Management Plan

- (1) General Requirements
 - a. An approved Storm Water Pollution Prevention Plan (SWPPP) for projects 1-acre or larger will be required prior to obtaining a digging permit.
 - b. Direct the Contractor to submit the SWPPP to the University Project Manager and the Occupational and Environmental Health & Safety Department for review.
- (2) Maintenance and Escalation of Best Management Practices
 - a. The density of developed area and close proximity of impervious surfaces requires

proactive storm water protection at the University of Utah. Impermeable surfaces adjacent to construction sites are to be kept free of sediment and construction site debris. The University requires all contractors to ensure that these potential pollutants be controlled to the "Maximum Extent Practicable" (MEP) as defined by the Federal Clean Water Act (CWA) part 402(p)(3)(B)(iii). In situations where the installation of a Best Management Practice (BMP) has proven ineffective (two or more corrective actions issued) the University of Utah will require alternate BMPs.

- (3) Long Term Storm Water Controls
 - a. The design team shall complete the University's Utah Pollution Discharge Elimination System (UPDES) submittal form for Long Term Storm Water control compliance. Describe why the specific long-term storm water controls were selected, the pollutant removal expected from the selected controls and the technical basis that supports the performance claims for the selected controls. For a copy of this form, please see the forms section on the University's Documents and Standards web page.
- (4) Job-Site Cleanup Responsibilities
 - a. Specifications shall identify daily, weekly, and job completion cleanup responsibilities for the removal of garbage, rubbish and unused materials.
 - b. Require the Contractor to coordinate daily cleanup operations in areas of the jobsite which may be affected by surrounding University activity. Construction activities shall be coordinated with the University Project Manager to reduce congestion and limit interruption of University traffic, operations, graduation ceremonies, etc.
 - c. Facilities Management approval shall be included in the final project cleanup process.
- (5) Construction Dewatering
 - a. The A/E shall consider possible needs for dewatering during construction. When needed, include mitigation measures in the design to prevent erosion (i.e., seeding, landscaping, etc.).
 - b. Any dewatering system design shall be submitted for review and approval by Facilities Management. Dispose site water to an existing underground gravity flow system that is approved by Facilities Management.
 - c. Dewatering systems should be of the gravity underground type, but may be pumped or flow overland if prior approved by Facilities Management through the University Project Manager.
 - d. Require that all dewatering systems be maintained and operated by the Contractor during the entire construction of the project. The system is not to be shut down or interrupted without Facilities Management approval.
- (6) Erosion Control
 - a. Avoid disturbing areas of high erosion susceptibility, sensitive vegetation areas, and areas with steep slopes.
 - b. Provide special erosion control measures on slopes greater than the angle of repose necessary for natural erosion control. Coordinate erosion control measures with the soils engineer.
 - c. Create an erosion control and sedimentation plan for all construction activities associated with the entire project site. The plan shall incorporate practices for stock piling of top soil for reuse, seeding, grading, mulching, filter socks, stabilized site

material shall

be recycled to the greatest extent possible to limit import/export and meet the University's sustainability goals.

- ii. The report shall prioritize the use of onsite soils and any soil amendments to reduce import/export.
 - iii. The report shall include recommendations for the modification of non- acceptable soils for reuse on site.
 - iv. The report shall indicate appropriate locations where on-site soils can be used (*i.e.*, trench backfill, etc.).
 - v. The report shall indicate soil suitability for storm water infiltration and include infiltration rates and recommended methods, if requested, based on permeability testing.
 - vi. The report should contain recommendations for at least one foundation system and describe precautions to be taken for special problems such as expansive soils, collapsible soils, etc.
 - vii. Special attention is to be given to the possibility of expansive soil conditions.
 - viii. In roadway or parking lot areas, the report shall contain recommendations for roadway and parking lot cross sections including asphalt or concrete thickness and thickness of accompanying road base.
 - (a) Pay particular attention to areas where the asphalt or concrete paved surface will be subject to heavy loads. The pavement section may require special design to ensure long use with minimal maintenance. Consult with Facilities Management through the University Project Manager to determine where heavy use design will apply.
 - (b) As an alternate for University consideration, the report shall include at least one pavement section that incorporates rubberized asphalt (at a minimum as a top layer), or pervious (gap graded) asphalt or concrete. The A/E will consult with Facilities Management through the University Project Manager about the possibility of including at least one section as an alternate bid item in the bidding documents. Options might include pervious concrete, 4" asphalt over 8" road base, pervious concrete over 18" gravel, etc.
 - ix. The report shall have a specific section addressing site specific sustainability recommendations to support the University's sustainability goals and climate change concerns.
- d. The A/E shall modify project plans and specifications appropriately to incorporate the soils engineering firm's recommendations.
- (2) Backfill
- a. To the greatest degree possible, on-site materials are to be evaluated for suitability as structural backfill. The University desires to use on-site materials to the greatest degree possible as long as there is no loss of quality or stability.
 - b. The A/E should carefully define minimum acceptable standards for structural backfill, and quantify on-site sources of acceptable material.
 - c. Minimize the potential for change order cost issues by including material unit prices on the bid form. These unit-cost items should be clearly described in the measurement and payment section of the specifications. Coordinate unit pricing and alternate pricing schemes with Facilities Management through the University

Project Manager during design.

(3) Excavation

- a. Alternate Storage Site: Specify that any excavated soil identified for use as backfill is to be stored at the project site. Where this is not feasible, an alternate temporary storage site should be arranged with Facilities Management through the University Project Manager. Such storage shall be discussed and arranged with Facilities Management early in the design process.
- b. Soil Not Usable as Backfill: Direct the Contractor to remove and legally disposed of any excavated soil not identified for use as backfill. There will be no permanent dumping on University property

(4) Compaction

- a. Specify that backfill shall be properly laid and compacted in lifts to the following standards. Where specific compaction recommendations are included in the soils report for the project, the soils report recommendations shall be followed in lieu of the following standards.
 - i. In lawn and landscaped areas: 85% of maximum dry density, 12-inch layers.
 - ii. In sidewalks, roads, parking areas or under buildings: 96% maximum dry density, 8-inch layers.
- b. Compaction testing shall be required. Coordinate the need for anticipated testing with the University Project Manager who will arrange a contract for the services of an independent testing firm. Note: The first test will be provided by the University, but any retesting due to test failure will be at the Contractor's expense.
 - i. The A/E shall include testing requirements for the Contractor and the testing firm in the project specifications. Duties of the University's testing firm should also be made a part of the specifications.
 - ii. Specifications shall indicate the testing frequency and type.
 - iii. Include in the specifications, "Failure of Facilities Management or the A/E to detect defective work or material does not prevent later rejection of the work, nor obligate the A/E for final acceptance when such defective work or material is discovered."
 - iv. Include in the specifications a list of informational items required for submittal.
 - v. A test schedule shall be included in the specifications.
 - (a) Curb and gutter with grade less than 0.5%: One random test per lift per 200 lineal feet.
 - (b) Curb and gutter with grade greater than 0.5%: One random test per lift per 400 lineal feet.
 - (c) Sidewalk: One random test per lift per 400 lineal feet.
 - (d) Trenches: One random test per lift per 200 lineal feet.
 - (e) Roadways: One random test per lift per 1000 square yards.
 - (f) Landscape Areas: No specific requirements.

3.3 Architectural

A. New Roofing Requirements

- (1) Contractor Roofing Warranty/Guarantee
 - a. Modifications shall not negatively impact existing warranties and shall themselves carry a 5-year workmanship warranty.
- (2) Roofing Systems
 - i. 80-mil or thicker shall be used for areas with mechanical equipment or other areas requiring heavier traffic. Ballasted roofs are not allowed.
 - ii. Georgia-Pacific "DensDeck" roof boards or prior approved equal shall be specified as underlayment between the insulation and the membrane where more than light or occasional foot traffic is anticipated.
 - b. Roof areas underneath any overburden such as soil, plantings or concrete shall be a built-up modified asphalt system such as Hydrotech Garden Roof (American Hydrotech, Inc.) or prior approved equal.
 - i. The built-up modified asphalt system under overburden shall include appropriate protection boards, drainage layers and drain protection methods.
 - c. Roof slopes greater than 2:12 shall be an architectural laminated shingle or a standing seam metal roofing system.
- (3) Roof Access
 - a. All roof areas must be accessible via secured walk out door (strongly preferred) or secured fixed ladder access.
 - i. All means of roof access shall be keyed to the University roof master key.
 - b. Walk pads must be installed at all roof entry points including the tops and bottoms of ladders between levels, at roof access doors, at the front edge of roof hatches, around all equipment on the roof, and along the route connecting the roof access point to equipment or other traffic required routes.
- (4) Roof Drainage
 - a. Roof drain domes shall be metal. Acceptable brands are Zurn, Wade, Smith, and Josam.
 - b. Primary drains must be sumped below the main roof drainage plane.
 - i. If these non-standard methods of primary drainage are approved by variance, the design shall include heat trace equipment.
 - c. Drain sumps shall not be obstructed by equipment, overburden, or pavers.
 - d. Refer to [3.7 D](#) for additional rainwater/roof drainage details.
- (5) Roof Penetrations
 - a. Individual penetrations such as conduits and pipes should be separated by at least 12-in (24-in if penetrations are greater than 6-in diameter).
 - b. Where tighter clusters of penetrations are necessary (such as condensing unit line sets), pitch pans may be utilized. Pitch pans must be filled with two component sealant or self-leveling silicone sealant (Dow 890 or prior approved equal) made for this purpose (do not allow pitch or other asphaltic material). Insulation on line sets must not be continuous through pitch pans or other flashing (i.e., the seal must affix to the pipe, not to insulation).
 - c. Electrical lines through the roof or adjacent walls must be via rigid conduit, not flex.
- (6) Conduit and Pipe Supports
 - a. Exposed wood is not allowed on roof areas. Roof mounted pipe and conduit runs

must be supported on blocking manufactured for this purpose (U.V. resistant with integrated clamping and protective padding equal to "PipePier" by PipePier Support Systems).

(7) Equipment on Existing Roofs

(8) Mechanical Units, Curbs and Other Roof Top Equipment

- a. Mechanical units and other roof top equipment shall be designed to be installed in a location and manner that readily allows repair or replacement of the roof system without removal or disconnection of the equipment.
- b. All equipment and installations must be mechanically attached to the structural roof deck, parapet, or other structural element of the building using round flashable pipe supports.
- c. Equipment curbs are to be fully wrapped where feasible and capped with a metal cap. Joints in the cap must be standing seam and be accessible for maintenance. The cap design shall allow free drainage of water from the cap surface.

- i. Equipment shall mount to roof curbs via structural elements equal to Unistrut which bear on top of the metal curb cap but attach through the side of the curb cap (the top of the curb cap shall not be penetrated by fasteners). Where possible, do not allow conduit or line set penetrations to be routed through a curb cap – specify or detail separately flashed routing through membrane.

(9) Labeling of all Roof Mounted Equipment

- a. Require the contractor to notify the University Project Manager and Carpentry Shop when existing roof mounted equipment lacking labeling is encountered so that labeling or removal/disposal as appropriate can be pursued.

B. Roofing Requirements

(1) Partial Replacement or Extension of an Existing Built-up Roof (BUR)

- a. The termination (top edge) of the roofing plies must be at least 8-in above the roof surface in the immediate vicinity.
- b. All transitions from horizontal to vertical in the roofing plies or cap sheets of a BUR system require the use of cant strips to eliminate 90-degree bends. To further avoid such bends, BUR plies and cap sheets shall not be wrapped over the top of curbs or parapets unless specifically designed for this purpose by the manufacturer.
- c. All materials used in the creation of a BUR system, detail, or tie in must be protected from UV exposure by the use of aluminized roofing paint (silver coat), or properly imbedded granules, or the use of a compatible and purpose-made foil flashing.
- d. Any exposed mastic must be finished to a smooth surface and feathered edges.

C. Waterproofing and Sealants

(1) Fluid-Applied Waterproofing

- a. For all foundation /retaining walls (including walls which do not carry a building load and for slab-on-grade foundation walls) and for all underground horizontal structures (new and remodeled), provide the following:
 - i. Specify a complete hot or cold applied waterproofing assembly, a fluid

applied product over membrane system obtained from a single source manufacturer, and which will meet or exceed a 20 year guarantee/warranty and to comply with ASTM D412-06a, ASTM C836 / C836M-12.

- (a) The assembly shall have a proven record of superior performance commensurate with the 20 year guarantee/warranty and shall include surface conditioner (primer); adhesives and sealants; a monolithic (no seams) fluid applied waterproof membrane, drainage and protection board; Flashings, reinforcing fabric; drainage course, filter fabric, flexible waterproof boots; and perforated pipe adjacent to the base of the footing.
 - (b) A fully compatible electronic field vector mapping testing system shall be specified on any plaza type project requirement waterproofing on horizontal applications.
 - (c) All products used in the waterproofing system intended for a project are required to be the products of one manufacturer or part of the warranted system of the manufacturer (with one exception, the vector mapping system; however, the vector mapping system shall be certified to work with the intended system.
- ii. Before the Contractor orders waterproofing materials, require submittals describing the system and installer. Submittals are to be submitted through the

A/E and University Project Manager to Facilities Management for approval.

Include the following as a minimum:

- (a) A complete description of the fluid applied system assembly.
 - (b) Verification that all products are from one manufacturer except the vector mapping system.
 - (c) Verification that each product in the manufacturer's wall protection assembly must be manufactured for the intended use; and must be fully compatible with all other materials which will be used in the manufacturer's waterproofing assembly.
 - (d) Certification that the vector mapping system is compatible and fully functional with the intended fluid applied waterproofing system.
 - (e) Manufacturer's certification that the installer is fully qualified to apply the manufacturer's products to meet a 20-year warranty.
 - (f) A written commitment that a manufacturer's rep will be present on-site monitoring and inspecting the installation as it proceeds, and will submit regular reports to the A/E and University Project manager certifying compliance to manufacturer's installation requirements.
- b. Damp-proofing will generally not be allowed, but where seemingly appropriate, will be considered only through a Variance Request.
- c. Specify the following minimum installation requirements:
- i. Top of the waterproofing assembly will be 6-in below finish grade.
 - ii. The drainage and protection board is to be applied over the fluid applied waterproofing membrane.
 - iii. Gravel fill shall be a minimum of 12-in thick and protected with a filter fabric between the gravel and surrounding soil.

- iv. The filter fabric must completely envelope the gravel and perforated pipe from the wall surface near the top, along the outer gravel boundary, around the gravel base containing the perforated pipe, and terminating over the flashing at the footing base.
 - v. The upper fabric connection at the top of the gravel fill must be affixed to the drainage/protection board.
 - vi. The lower fabric connection near the bottom of the gravel fill must be affixed to the drainage/protection board above the footing.
 - vii. Specify either a 4-in or 6-in diameter perforated pipe at the base of the footing in the gravel. Engineer the pipe to meet the anticipated soil moisture conditions.
 - viii. Direct the contractor to set the top of the perf-pipe below the top of the footing.
 - ix. Fluid applied waterproofing is to be applied in two directions. The horizontal application shall be installed with reinforcing fabric to a thickness of 215-mil. The vertical application shall be installed to a thickness of 180-mil applied in two 90-mil applications.
- d. Require the Contractor to adhere to specific restrictions imposed or recommended by the manufacturer for environmental conditions, product delivery, inspection, storage handling, product protection, surface inspection, surface preparation, product application, etc.
- e. Guarantee/Warranty
- i. At the conclusion of the installation, require the manufacturer's rep to certify verification that the installed system is leak free; that the membrane application is tight without voids; and that the system assembly including the applied mil thickness meets the manufacturer's requirements for the 20-year guarantee/warranty period.
 - ii. Before accepting the installation for plaza (horizontal) applications, require the installer or manufacturer's representative to demonstrate to the A/E and University complete functionality and continuity of the vector mapping system within the completed waterproofing system.
 - iii. The guarantee shall include the cost of materials and labor (no dollar limit and not pro-rated), and include the removal and reinstallation of landscaping, soil, paving, etc., to access the area to be repaired/replaced.
 - iv. If during the 20-year period, either the manufacturer or contractor goes out of business, the other is required to assume full responsibility for the guarantee/warranty.
- (2) Joint Sealants
- a. For joint sealants in above-grade concrete walls, metal window walls (i.e. curtain walls), and in-between concrete and metal elements use silicone sealant equal to Dow 790, Dow 795, Sika WS 290, or Sika WS 295.
- D. Acoustical Quality
- (1) Classroom walls shall be designed to STC (Sound Transmission Class) 50 minimum. Spaces with even higher sensitivity shall be designed to STC 55 minimum.

- (2) Ceiling materials in halls and lobbies with carpeted floors shall have an NRC (Noise Reduction Coefficient) of at least 0.5. Ceiling materials in halls and lobbies with hard floors shall have an NRC of at least 0.65.
 - (3) An acoustical engineering consultant for special use halls, classrooms, and lecture spaces is recommended. Obtain services before shape of space is fixed.
- E. Exterior Insulation & Finish Systems (EIFS)
- F. Building Graphics
- (1) Exterior Building Graphics
 - a. The A/E shall coordinate with the University Project Manager regarding the latest changes to this standard.
 - (2) Interior Building Graphics
 - a. This item includes room numbers, room names and a standard building dedication plaque.
- b. Academic Branding. If the building interior is designed using a coordinated functional branding theme, room identification graphics, way finding graphics, International Building Code, ADA, directional graphics, etc., will require review and approval by Facilities Management early in the design. Consideration will be given to materials, aesthetic coordination, size and serviceability of the proposed graphics by the University Sign Shop.
- c. Standard University Interior Graphics.
- i. Interior graphics on campus have been standardized for buildings which will not have a coordinated functional theme.
 - ii. Specify sign panels to be ADA compliant, raised character, acrylic multipolymer sign panels with square edges and Braille (acrylic beads), tactile text shall include painted acrylic backers and square edges.
 - iii. Require copy / typographic letterforms and symbols to be router cut using multipolymer engraving stock, appliquéd with permanent, proven adhesive specified by the product manufacturer and rated for exterior environments. Text shall be 1/32-in thick or as noted in current ADA standards. Braille text shall utilize individual clear acrylic beads. Note: Router cut Braille text is not acceptable.
 - iv. Panel and sign backer thickness, sizes and finishes are to be noted on the project drawings. All panels are to be specified to be precision cut and finished. Low gloss finish shall be ADA compliant (20% reflectance is desired).
 - v. Coordinate the intended method of sign mounting with the University Project Manager and Sign Shop.
 - vi. Sign panels with changeable paper inserts shall be specified with square edge sign face and clear acrylic window panel to accommodate changeable, laser / color printed paper sign inserts. Note: The initial paper inserts are to be provided and installed by the installing supplier/contractor. The acrylic top layer shall have a precision cut window to expose the bottom layer. The sign face sizes and thicknesses shall be scheduled on the drawings.
 - vii. Require the supplier/contractor to submit final layouts and text as well as symbol locations to the designer and University Project Manager for approval prior to fabrication or installation of any signs. Signs shall conform to applicable code requirements. Life safety maps and related signage are

subject to Fire Marshal review and approval, and shall conform to Fire Marshal's requirements. When signs are initially installed – and when changeable insert messages are not ready or finalized – the supplier/contractor shall insert heavy blank paper (black in color) into the paper message signs to provide a complete and finished appearance (unless the background area behind the sign window is already black).

d. The following are examples of the University standard for interior sign graphics:

- i. Sign Type A1/00 – Small Door ID Sign. Painted acrylic backer with square edges and modified acrylic sign face with square edges, Braille beads and applied machine engraved tactile graphics:

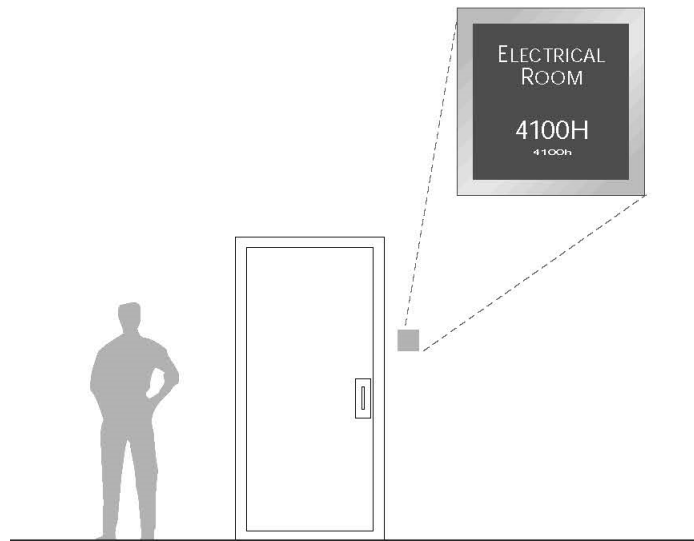

SIGN TYPE A1/00 - Small Door ID Sign

Painted acrylic backer with square edges and modified acrylic sign face with square edges. Braille beads and applied machine engraved tactile graphics.

- ii. Sign Type A3/00 - Large Door ID Sign. Painted acrylic backer with square edges and modified acrylic sign face with square edges, Braille beads and applied machine engraved tactile graphics.

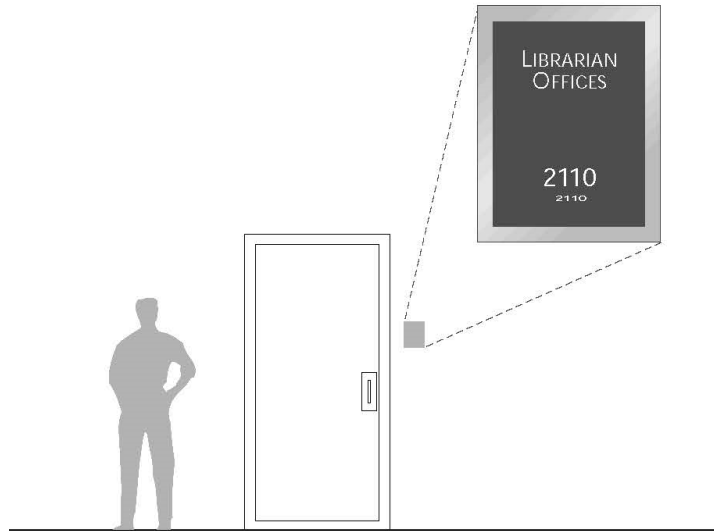

SIGN TYPE A3/00 - Large Door ID Sign

Painted acrylic backer with square edges and modified acrylic sign face with square edges. Braille beads and applied machine engraved tactile graphics.

- iii. Sign Type A4/00 – Small Door ID / Changeable Painted acrylic backer with square edges and multi-layered modified acrylic sign face with square edges, routed window and Braille beads and applied machine engraved tactile graphics. Window for printed paper insert.

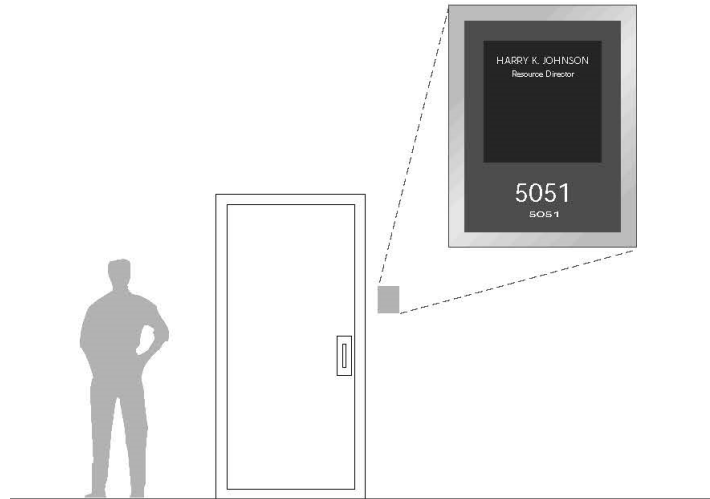

SIGN TYPE A4/00 - Small Door ID / Changeable

Painted acrylic backer with square edges and multi-layered modified acrylic sign face with routed window and square edges. Braille beads and applied machine engraved tactile graphics. Window for paper insert.

- iv. Sign Type A5/00 – Medium Door ID / Changeable. Painted acrylic backer with square edges and multi-layered modified acrylic sign face with routed window and square edges, Braille beads and applied machine engraved tactile graphics. Window for printed paper insert.

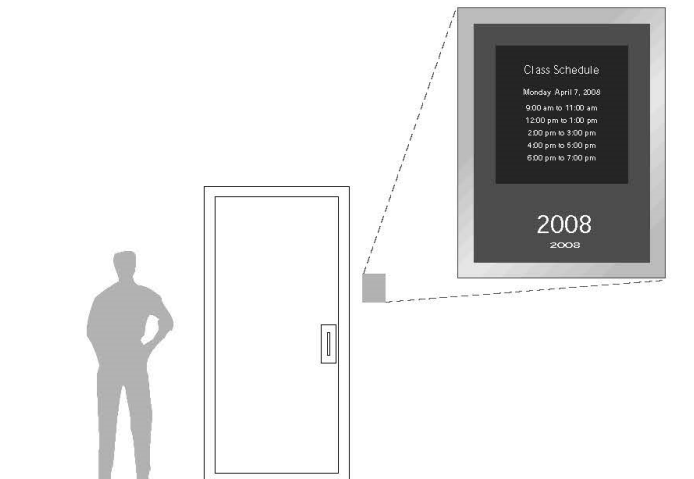

SIGN TYPE A5/00 - Medium Door ID / Changeable

Painted acrylic backer with square edges and multi-layered modified acrylic sign face with routed window and square edges. Braille beads and applied machine engraved tactile graphics. Window for paper insert.

- v. Sign Type A7/00 – Restroom ID / Women. Painted acrylic backer with square edges and modified acrylic sign face with square edges, Braille beads and applied machine engraved tactile graphics.

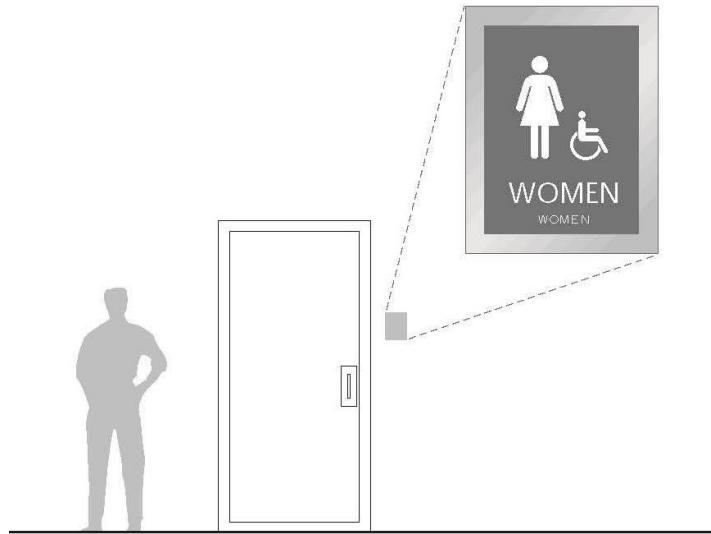

SIGN TYPE A7/00 - Restroom ID / Women

Painted acrylic backer with square edges and modified acrylic sign face with square edges. Braille beads and applied machine engraved tactile graphics.

- vi. Sign Type A11/00 – Stair Code Sign. Modified acrylic sign face with square edges, Braille beads and applied machine engraved tactile graphics.



SIGN TYPE A11/00 - Stair Code Sign

Modified acrylic sign face with square edges. Braille beads and applied machine engraved tactile graphics.

- vii. Sign Type A12/00 - Single Use Restroom (family or assisted use) Sign. Lettering shall state “All Gender Restroom”. Painted acrylic backer with square edges and modified acrylic sign face with square edges, Braille beads and applied machine engraved tactile graphics. Corners may be radius or square to match other sign types.

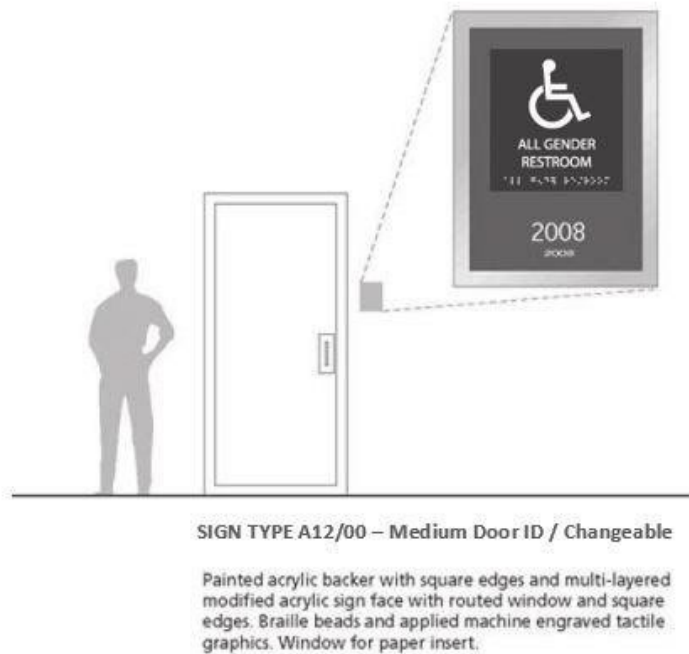

G. Custodial Closets

(1) General Requirements

- a. Square or rectangular closets are required.
- b. Space for three separate custodial closet functions shall be included in every building. Individual rooms shall be provided for one or more wet closets, one or more dry closets, and one office closet.
- c. For existing buildings, the A/E’s design responsibilities for building alterations and/or additions shall include a review of the entire building’s custodial conditions with regard to the requirements described herein. The project scope for the remodel and/or addition shall include additional custodial space where needed to meet the building’s overall custodial space requirements.
- d. Access to each custodial closet/office shall be along a direct route from a main hallway.
- e. Each custodial closet/office door shall have means to hold the door in the open position (*i.e.*, door stops, or closers with a ‘hold-open’ feature) as allowed by code.
- f. Closet floors shall be quarry or ceramic tile (preferred); or concrete with an appropriate sealed surface treatment.

(2) Wet Closets

- a. Each wet closet shall be centrally located in its service area.
- b. The minimum footprint for each wet closet shall be no less than 100 square feet with the shortest wall length no less than 6 feet.

- c. The door width for each wet closet shall be 36-in unless requested otherwise by Campus Custodial Services. All wet closet doors shall swing out, not into the custodial space.
 - d. For floor areas per level equal to, or less than 40,000 gross square feet, provide one wet closet per floor level.
 - e. For floor areas per level greater than 40,000 square feet, the project design must include additional wet closets (one for each 40,000 gross square feet or portion thereof).
 - f. When multiple wet closets are provided on a floor level, divide the floor into equal service area segments and locate each closet centrally in its service area, preferably near restrooms.
 - g. The design shall include a floor mounted service sink with a minimum size of 15 square feet. The edge of the sink shall be no higher than 6-in above the finished floor.
 - h. The design shall include a wall mounted hanger rack for wet mops (minimum of four hangers) which shall be installed over the service sink.
 - i. The design shall include adequate wall space for a chemical dispensing system which will be located over the service sink. Minimum wall space required is 2-ft x 2-ft, located directly over the hose bibs.
 - j. The design shall include adequate clear wall space (at least 5-feet linear) for hangers to store brooms, ladder, etc.
 - k. Installed along one wall of the closet, the design is to include a minimum of five (5) adjustable height shelves (adjustable from floor to ceiling). Shelves shall be 14-in deep. Do not locate the shelving system behind a door.
 - l. Include a minimum of one electrical outlet in each wet closet, installed in an approved location.
- (3) Dry Closets
- a. Each dry closet shall be centrally located in its service area.
 - b. The minimum footprint for each dry closet shall be no less than 200 square feet with the shortest wall length no less than 8-feet.
 - c. The door width for each dry closet shall be 42-in unless requested otherwise by Campus Custodial Services. All dry closet doors shall swing out, not into the custodial space.
 - d. For buildings equal to, or less than 150,000 gross square feet, provide one dry closet per building.
 - e. When the building exceeds 150,000 gross square feet, a second dry closet of the same size shall be provided. Divide the building into equal service area segments and locate each dry closet centrally in its service area.
 - f. The design shall include adequate clear wall space (at least 6 lineal feet) for hangers to store brooms, equipment, ladder, etc.
 - g. Installed along two adjoining walls of the closet, the design is to include a minimum of five (5) adjustable height shelves (adjustable from floor to ceiling), suitable for storing heavy items. The University Project Manager will provide to the A/E the required shelf depth for each dry closet, as directed by Campus Custodial Services (depth will generally be either 14-in or 18-in). Each wall's installation of the two adjoining shelving systems shall be no less than 6-feet long. Do not locate the shelving system behind a door.
 - h. The design is to include a 6-ft high x 5-ft wide x 14-in deep (minimum size) lockable cabinet that is designed specifically to store and secure cleaning chemicals.
 - i. Include two (2) GFCI four-plex electrical outlet boxes located in approved locations. These

outlets require dedicated circuits due to the nature of their use.

(4) Custodial Office

- a. Each building shall have one custodial office.
 - i. For floor areas per level equal to or less than 150,000 gross square feet, the minimum footprint for the custodial office shall be no less than 120 square feet with the shortest wall length no less than 8 feet.
 - ii. For floor areas per level equal greater than 150,000 gross square feet, obtain the required minimum space dimensional requirements from Facilities Management through the University Project Manager, who will coordinate with Custodial Services. This information must be obtained early in design to avoid space and usage conflicts as the building floor plans are developed.
- b. The design is to include either a built-in desk or sufficient room for a 60-in x 30-in desk with a three-drawer filing cabinet, furnished and installed as part of the project.
- c. The design is to include a shelf installed on the wall above the desk. The shelf shall be 48-in long and 12-in deep. Do not locate the shelf where it will conflict with the door.
- d. The design is to include a wall mounted staff locker system in the custodial office.
 - i. For buildings with an overall floor area (the sum of all levels) up to 20,000 gross square feet, specify four (4) full height wall mounted staff lockers in the design.
 - ii. For buildings with an overall floor area greater than 20,000 gross square feet, specify ten (10) half-height lockers in a wall mounted system.
- e. Include electrical outlets located in approved locations for computers and electronic equipment.
- f. The design is to include wall connections for computers, internet access, and phone service.
- g. The custodial office may be located adjacent to a dry closet if approved by Facilities Management and Campus Custodial Services, through the University Project Manager.
 - i. This arrangement will require separation by a wall and a door, with each space forming a complete dry closet and a complete custodial office.
 - ii. Any consideration for adjacency shall be submitted to Facilities Management early in design. A proposed layout and location for this arrangement shall be reviewed in a meeting between the A/E, the University Project Manager, and the Campus Custodial Services.

H. Lactation Rooms

- (1) The design for new construction, major building alterations or major building additions (defined as having a total project budget of \$10 million or more) shall comply with the lactation room requirements provided herein.
- (2) One lactation room shall be provided on the first floor of each building.
- (3) Access to the lactation room shall be along a direct route from a main hallway.
- (4) The minimum footprint shall be no less than 9-ft x 6-ft.
- (5) Doors shall be equipped with a privacy lockset.
- (6) Walls shall be insulated for sound.
- (7) Flooring shall be carpet.
- (8) Walls are to be painted.
- (9) A countertop 2-ft depth shall be provided along one wall. The space beneath the countertop shall be open. A hand sink shall be provided in the countertop.
- (10) Lighting levels shall be between 30 to 50 foot-candles
- (11) A 110v GFI outlet shall be provided at the countertop and at the wall nearest the chair

placement.

- (12) Each room should have the following furnishings and equipment:
- a. One Upholstered non-caster chair with arms.
 - b. A wall mounted mirror above the counter
 - c. Soap and Paper Towel dispensers
 - d. Waste Receptacle
 - e. Wall Mounted Clock
 - f. Wall or Door Mounted Robe Hook
- (13) Door Signage shall be a room number
- I. Concrete
- (1) Install exterior concrete stairs with tooled nosings only.
- J. Metals
- (1) Structural Steel Framing
- (2) Steel Bollards
- a. Steel bollards shall be minimum 6-in diameter standard steel pipe, set in minimum 24-in diameter x 48-in concrete footings, painted black with two rows of white Scotchlite reflective tape spaced 2-in apart and placed 4-in below the top of the pipe. Pipe shall be a minimum of 48-in above finish grade and filled with concrete full height, with concrete mound at top, painted white. Provide sealed expansion joint around steel pipe and asphalt or concrete paving.
- (3) Exterior Pipe and Tube Railings
- a. Guardrails
 - b. Ramp Handrails
 - i. 1.66-in diameter stainless steel handrails are to be anchored to 2.5-in square stainless steel tube posts spaced at a minimum of 4-ft on center to a maximum of 6-ft on center.
 - ii. Provide a 1.66-in diameter stainless steel bottom rail centered 4-in above finish grade between vertical posts. All connections to be welded. Handrails to be 36- in clear between rails.
 - c. Handrail Post Caps
 - i. Anti-Skateboard handrail post caps shall be .375-in x 2.5-in x continuous stainless steel plate with .25-in radius edges and be welded to a 1.9722-in diameter x .375-in steel tube cap plate welded to a 1.8722-in diameter x 0.120- gauge x 2-in steel tube welded to a stainless steel cap plate welded to the top of each vertical post. See detail below.
 - d. Handrail Post Anchoring
 - i. 2.5-in square stainless steel handrail posts shall be set into 4-in diameter x 6-in deep core drilled holes in concrete paving with cementitious anchoring compound full height of core drilled hole.
 - ii. Posts shall be set a minimum of 3-in back from the paving edge or joint.
 - e. Handrail Profile
 - i. 2.5-in square stainless steel handrail post caps shall extend a minimum of 4-in above handrails. Anchor 1.66-in diameter stainless steel handrails to posts with .75-in diameter stainless steel rods, welded both ends.

f. Exterior Stair Handrails

- i. 1.66-in diameter stainless steel stair handrails to be anchored to 2.5-in square stainless steel tube posts at a minimum of 4-ft on center and maximum 6-ft on center.
- ii. Anchor 1.66-in diameter stainless steel handrails to posts with .75-in diameter stainless steel rods, welded both ends.

g. Handrail Details

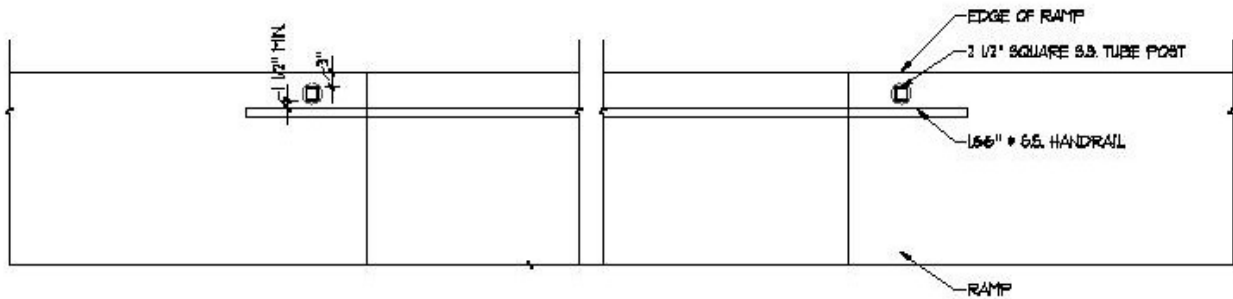

PLAN - HANDRAIL AT RAMP

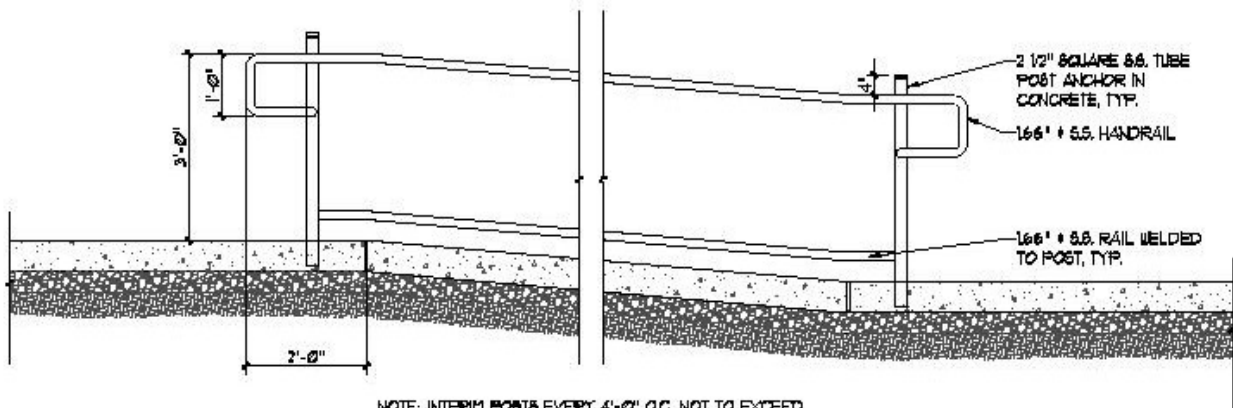

NOTE: INTERIM POSTS EVERY 4'-0" O.C. NOT TO EXCEED 6'-0" O.C. RAMP TO HAVE 36" MIN CLEAR. BETWEEN HANDRAILS

SECTION - HANDRAIL AT RAMP

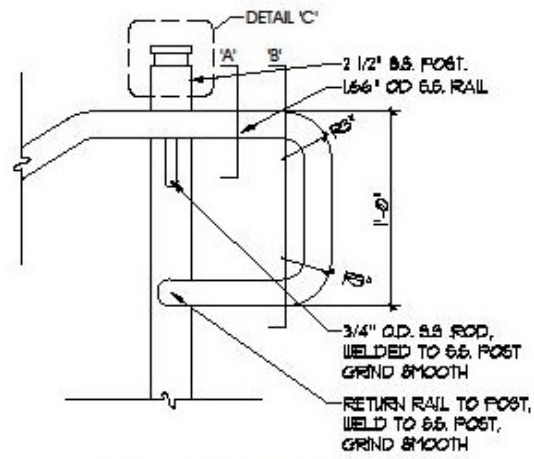

DETAIL 'D' - PIPE HANDRAIL

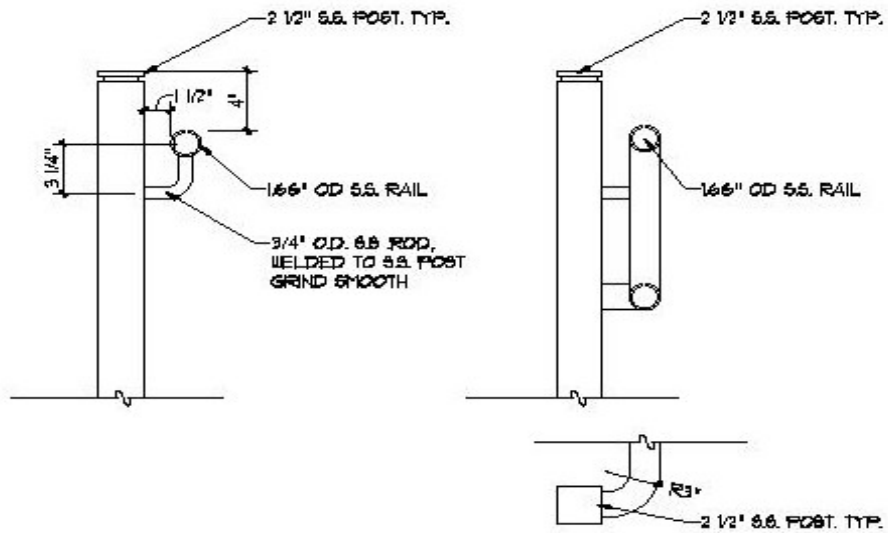

**SECTION 'A'
PIPE HANDRAIL**

**SECTION 'B'
PIPE HANDRAIL**

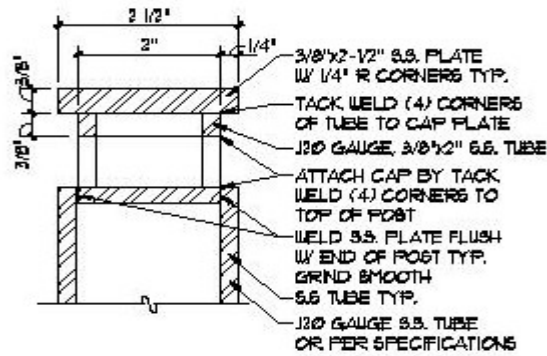

DETAIL 'C' - PIPE HANDRAIL POST CAP

K. Wood, Plastics, and Composites

(1) Rough Carpentry

- a. Any necessary wood framing, blocking, furring, etc. shall be fire treated.
- b. Provide sheet metal backing at sill to 6-in above the floor.
- c. Standards: AWPA P49, AWPA M2 and AWPA U1.

(2) Plastic-Laminate-Clad Architectural Cabinets

- a. All plastic laminated tops and shelves shall be minimum 1-in thick and edge banded.
- b. All cabinetry shall be designed and constructed to meet or exceed, the latest AWI Quality Standards, Custom grade or better. The University requires the following upgrades to the AWI Quality Standards:
 - i. No composite materials (particle board, fiber board, Masonite, OSB, etc.) shall be allowed within 4-in of the finish floor in laboratories, classrooms, restrooms, janitorial closets, or any area where water may be present. Specify pressure treated lumber, exterior grade plywood, or lumber rated by AWI for exterior use.
 - ii. All interior joints in cabinets where sinks will be installed shall be caulked.
 - iii. The front bottom edge of countertops and aprons where sinks are installed shall be edged in accordance with one of the following requirements:
 - (a) The countertop shall have a raised no-drip bullnose edge flush with the front apron.
 - (b) The countertop shall have a 1.5-in self-edge projecting .75-in beyond the face of the apron.
 - (c) The countertop shall have a bullnose edge flush with the face of the apron.
- c. Cabinets shall be designed and fabricated to meet the following
 - i. additional criteria (for laboratory countertops, see [3.3 Q \(3\)](#), for laboratory cabinets see [3.3 R \(1\)](#)):
 - i. Cabinet design shall be modular to the greatest extent possible to facilitate reuse in the event of future remodeling. Modules of 18-in, 24-in, 36-in etc., are to be used.
 - ii. Include allowances in the base cabinet to allow for minor vertical adjustments.
 - iii. Material selection shall be based on the intended use. Sinks shall be in accordance with [3.3 Q \(3\)](#).

- iv. Individual components shall be as follows:
 - (a) Hinges shall be 5 knuckle types.
 - (b) Slides shall be full length with nylon or stainless steel bearings
 - (c) Wood cabinets are acceptable for bio-safety less than level 3. Melamine or plastic laminate is acceptable.
 - (d) Door fronts shall be edge banded on all four sides and sealed with a durable finish for easy clean-ability.
 - (e) Consider "Sustainable Building Products" in the design and fabrication of cabinets. The A/E is expected to evaluate the possibility of such products and submit recommendations to the University Project Manager.

L. Openings

- (1) Metal Doors and Frames
 - a. General
- (2) Wood Doors
 - a. Wood Doors: Solid core doors faced with minimum of 1/16-in veneer finish are recommended. No wood doors to be used as exterior doors.
 - b. Sliding doors are not recommended.
 - c. Kick plates for doors in heavy traffic areas. This is to include classroom doors.
 - d. Mineral filled doors are not recommended.
 - e. Standards: Architectural Woodwork Institute (AWI/AWS).
- (3) Plastic Doors
 - a. Kick plates for doors in heavy traffic areas. This is to include classroom doors.
 - b. Mineral filled doors are not recommended.
- (4) Coiling Doors and Grilles
 - a. All roll-up fire doors shall be motorized and have automatic self-closing device or holder-release mechanism and governor unit complying with NFPA 80 and an easily tested and reset release mechanism. Testing for manually operated doors shall allow resetting by opening the door without re-tensioning the counterbalancing mechanism. Release mechanism for motor-operated doors shall allow testing without mechanical release of the door. Automatic-closing device shall be designed for activation by the following:
 - b. Building fire-detection, smoke-detection, and -alarm systems.
 - c. Limit Switches: Equip each motorized door with adjustable switches interlocked with motor controls and set to automatically stop door at fully opened and fully closed positions.
 - d. Obstruction Device
 - i. External entrapment device consisting of indicated automatic safety sensor capable of protecting full width of door opening. For non-fire-rated doors, activation of device immediately stops and reverses downward door travel. For fire-rated doors, activation delays closing.
 - e. All motorized roll up doors must have safety bar or motion sensor device to prevent door from closing on vehicles, equipment or persons.
 - f. Detection Devices: External entrapment protection consisting of indicated automatic safety sensor capable of protecting full width of door opening. For non-fire-rated doors, activation of device immediately stops and reverses downward door travel.

For fire-rated doors, activation delays closing.

(5) Door Hardware

- a. General:
 - i. Fire-Rated Door Assemblies
 - (a) Where fire-rated door assemblies are indicated, provide door hardware rated for use in assemblies complying with NFPA 80 that are listed and labeled by a qualified testing agency, for fire-protection ratings indicated, based on testing at positive pressure according to NFPA 252 or UL 10C, unless otherwise indicated.
 - ii. Smoke- and Draft-Control Door Assemblies
 - (a) Where smoke- and draft-control door assemblies are required, provide door hardware that meets requirements of assemblies tested according to UL 1784 and installed in compliance with NFPA 105.
- b. Provide lock sets as follows:
 - i. Mortise Locks: BHMA A156.13; Security Grade 1.
 - ii. Rigid function for custodial closets and mechanical rooms with 2-3/4 backset.
 - iii. DO NOT key restrooms.
- c. Electronic Locks
 - i. For interior doors in existing buildings without the CCure system, and where central monitoring by the University Public safety department is not needed, a Kaba Ilco with key bypass entry system will be installed. The system is to be operated, managed and maintained solely by the requesting department.
 - ii. All electronic locking systems shall comply with current specifications provided by the University's Alarm Committee. Upon request, the University will loan the A/E a confidential copy of the U of U Alarm Committee Approved Alarm Equipment document for use in the room security design.
- d. Cylinder Locks
 - i. High-Security Lock Cylinders: BHMA A156.30; Grade 1. Doors with cylindrical locks are to be specified with heavy duty Schlage or prior approved equal. As a minimum standard, specified locks are to conform to Schlage "standard 6 pin cylinders". Smaller formats are not acceptable. Interchangeable cores are not acceptable.
 - ii. Panic bars shall be specified Von Duprin 99 Series, or 33 Series on exterior doors where a narrow type device is necessary. All panic bars shall be rim type with removable mullions on double doors.
 - iii. On all new buildings, or on large remodel projects that require a large number of new locksets, the locksets are to be provided without cylinders or blanks. The University will furnish and install the cylinders in the locksets and provide the keys. Facilities Management will schedule and fund the installation of the keys and cylinders through the University Project Manager.
- e. Finish.
 - i. Match existing finish on remodeling projects.
- f. Door Closers
 - (a) Door closers shall not be located so that they are exposed to the weather. This is intended to reduce or eliminate the effect of water,

snow, ice, salt and freeze upheaval on the door.

(b) All steel doors 18-gauge or less must have backing plates to support mounting of door closer or door closer must be installed with thru bolts.

g. All control devices on automatic doors, such as pneumatic operators must be accessible with not more than an 8-ft ladder.

(6) Glazing

a. Glass Glazing

i. Glass to be cleaned by Contractor at job completion.

M. Finishes

a. Where doors that swing into an adjacent wall there must be a backing plate or fire treated wood blocking installed between studs to support sheet rock at the location where the door handles meet the wall to prevent damage and allow better mounting for wall mounted door stops.

(2) Terrazzo Flooring

a. Protective nosings for stairs.

b. Clean and wax floors before turning building over to the University for occupancy. Cleaning and waxing to be done according to manufacturer's recommendations. Floor finish should match that which is currently being used by the University. Concrete floors to be sealed with concrete sealer.

c. Recommended minimum height of base is 4-in.

i. Carpet color and type needs to consider maintenance issues such as staining and cycles of cleaning.

d. Rubber Base

i. Wall base shall be RUBBER BASE such as Johnsonite, Burke, Roppe or VPI. It shall be constructed of first quality materials properly vulcanized and shall be smooth and free from imperfections which detract from its appearance. The base shall conform fully to the requirements of ASTM F-1861, Type TP, Group 1 (solid) standard specification for resilient wall base.

(3) Wall Coverings

a. General

b. Description

i. Shall be Type II, Medium Duty, Class A Vinyl Coated Fabric Wallcovering for Institutional or Commercial use, conforming in all respects to CFFA Quality Standard for Vinyl Coated Fabric Wallcovering CFFA-W-101-A, developed and published in May 1984.

c. Fire Hazard Classification

i. Products shall bear the UL label or Manufacturer's Letter of Certification indicating fire hazard classification with flame spread in compliance with adopted codes and amendments in the State of Utah.

N. Specialties

(1) Visual Display Surfaces

a. Acceptable Boards: ADP Lemco or other boards with ten year warranties.

(2) Toilet Compartments

a. Urinal Screens

Products.

- b. Laboratory sinks shall be:
 - i. Molded Epoxy Resin to match Laboratory Tops
 - ii. Stainless Steel where radioactive isotopes are to be used in any quantity.
- c. For laboratory waste and drain lines, the A/E is requested to design and specify the under-sink fittings in Pyrex glass. However, "Durcon" and "Duriron" will be acceptable substitutes. Refer to [3.7 C \(10\)](#) for additional requirements.
- d. Laboratory benches shall be designed and installed to facilitate maintenance on all utilities serving the bench. This will require the provision of removable panels so that all fittings can be reached without disassembling the bench.
- e. Paper towel dispensers shall be provided in laboratory areas over each sink. Scott Model #995 (white enamel) or equal.

P. Furnishings

(1) Laboratory Casework

- a. All cabinetry shall be designed and constructed to meet or exceed, the latest AWI Quality Standards, Premium grade. Refer to [3.3 M \(2\)](#) for typical requirements.
- b. Laboratory cabinets shall be designed and fabricated to meet the following additional criteria:
 - i. Material selection shall be based on the intended use.
 - ii. Laboratory tops and sinks shall be in accordance with [3.3 Q\(3\)](#).
- c. Individual components shall be as follows:
 - i. Wood cabinets are acceptable for bio-safety less than level 3. Melamine interiors or plastic laminate is acceptable.

(2) Window Blinds

(3) Interior Recycling Bins

- a. Below is a list of areas and the materials that are required for new state funded facilities. To be ordered thru the Waste Management Department.
 - i. Office areas: One 13-qt office pack bin for each desk, and one 23-gal mixed pack bin for each room/cubicle area.
 - ii. Classrooms: One 28-qt mixed pack bin.
 - iii. Conference/Break Rooms: One 28-qt mixed pack bin
 - iv. Copy Rooms: One 23-gal office pack bin and one 28-qt mixed pack bin.
 - v. Labs: The type of lab determines the bin type, size and quantity. For example, a chemistry lab would only require a 23-gal mixed paper bin while a computer lab would require two 23-gal office pack bins and one 23-gal mixed paper bin. This decision is made by the Waste Management and Custodial Departments.
 - vi. Building Entrances: One for bin recycling center at all major entryways.
 - vii. Hallways: One 4-bin recycling center on each floor, this does not include the recycling centers provided at major entryways. Vending machine areas required 30-gal recycling bins for plastics and /or aluminum depending on the type of beverage container dispensed by the machine. Mixed paper recycling bins are also required in hallways and common areas. The size, type and quantity of the paper recycling bins are decided by the Waste management and Custodial Departments.
 - viii. Restrooms: Recycling bins are not required in restrooms.
 - ix. Café Areas: Recycling in café areas is the responsibility of the vendor.

- x. Dock Area: A cardboard recycling trailer is to be provided. The trailer can be purchased thru the Waste Management Department. If the trailer is purchased independently it must follow the specifications provided by the Waste Management Department.

Q. Vivariums

- (1) Planning and design of Vivariums should be in close coordination with the University Director of Comparative Medicine. The A/E shall coordinate a vivarium planning meeting with the University project manager and the University director of comparative medicine during the planning stage of the project.
 - a. The meeting shall specifically cover and plan for the required surface finishes, space requirements, need for special behavior rooms, sound proofing, mechanical systems, security requirements, and Facilities for cleaning.
 - b. Notes from this meeting shall be distributed to the planning team and kept as part of the project record.
- (2) Common Work Results for Special Construction
 - a. Epoxy treatment of walls and floors has proven advantageous in some areas on previous projects.
 - b. A monolithic type flooring, similar to "Dex-O-Tex" produced by Crossfield Products, with its own elastic membrane and the necessary coves at walls and corners appears advisable in areas where a waterproof, washable floor is mandatory.
 - c. Plain, sealed concrete has proven unsatisfactory. Floor cracking creates serious problems.
 - d. Vivarium design shall be in accordance with the guidelines outlined in the latest edition of the "Guide for the Care and Use of Laboratory Animals" and Section 2-4 of NIH Policies and Guidelines. Specifically referencing the guidelines for physical plant design.

R. Elevators

- (1) Specify removable full-height bumper blankets for wall protection in elevators primarily intended for freight, supplies, equipment, etc.
- (2) See [3.11 F \(35\)](#) for special requirements regarding elevator phones and phone panels, elevator communications connections (traveling cable), access panels, conduit, emergency service lines, etc.

3.4 Structural

A. Concrete

- a. Reinforcing steel shall be minimum grade 60; fy=60 ksi.
- b. Sidewalks throughout campus are to be rated for heavy vehicle use, refer to [3.2 A \(1\)](#) for specific requirements. At a minimum, provide a 6-1/2 bag mix. Provide additional reinforcing, thickness, etc. as use requires.

3.5 Electrical

A. Lighting

- (1) Interior Lighting
 - a. Maintainability
 - b. Spare Fixture Lenses
 - i. Require the Contractor to provide 10% of each type and size specified with a minimum 2 of each. Coordinate storing and delivery of spare lenses with the University Project Manager.

- c. Lighting Control
 - i. A lighting control system should be provided for the interior lighting of all new buildings. The system shall be compatible with BACnet data communication protocol.
 - ii. Lighting control systems shall have either an open or direct interface and keyboard, keypad or touchscreen access.
 - iii. Lighting control systems specified for building additions shall be compatible with existing systems, additions, alterations.
 - d. Fluorescent
 - i. Fluorescent ballasts shall be programmed start.
 - ii. Premium lamps and ballasts shall be specified.
 - iii. Do not specify, nor allow compact fluorescent downlight fixtures.
 - (a) When the project's emergency power needs will draw from a nearby generator at another building, confirming capacity calculations (starting and load calculations) for the existing off-site generator shall be submitted to Facilities Management through the University Project Manager for review and approval prior to completing the design.
 - (b) Remodeling projects at buildings with no access to an emergency generator may warrant the use of rechargeable batteries as the source of alternate power. If battery power is considered, the A/E shall submit a request for its use to Facilities Management through the University Project Manager, and obtain written approval. When used, battery powered systems shall include automatic chargers and exercisers.
 - e. Emergency Exit Signs.
 - i. Emergency exit signs shall be typically specified as long life LEDs.
- (2) Exterior Lighting
- a. The technical standards for exterior lighting applies to all University properties. The aesthetic standard for exterior lighting applies to Lower Campus, Health Sciences Campus and Ft. Douglas. Aesthetics for all other areas should be consistent with the architectural context of the area.
 - b. Exterior Lighting Controls
 - i. Each outdoor lighting circuit shall be controlled by a magnetically held 50A, 3P, 480V lighting contactor with a hand-off-auto selector switch and a photocell (120 v) in its own enclosure.
 - c. In-Concrete, In-Ground, and Bollard Lights Not Allowed
 - i. 'In-concrete' light fixtures (especially in exterior stairs and walls), 'in-ground' light fixtures, and bollard lighting systems are not allowed.
- (3) Exterior Pole Lights
- a. General
 - i. Exterior pole lights throughout campus are to be standardized for uniformity in appearance, light pattern, and light distribution; quality of unit fabrication, engineering, and assembly; and, reliability for long term University maintenance. Poles shall be standardized as either 10' for walkways & landscape on Main Campus and the Health Sciences Campus, 16' for walkway & landscape at Ft. Douglas or 20' for Parking lots and

Roadways. Light pattern and distribution requirements shall be coordinated with the University Lighting Specialist.

- (a) Colors of the poles lights shall be determined by the area in which they are located. Health Sciences shall have silver colored fixtures and poles, Main Campus shall have black fixtures and poles, and Fort Douglas shall have bronze fixtures and poles.
 - (b) Poles shall have a powder coated finish.
 - (c) Poles on the Main Campus and Health Sciences Campus shall be aluminum, 10-ft tall x 4.5-in straight round with the fixture end fabricated to match the appropriate fixture fitting, and all poles shall have a surface mounted round hinged base. Poles at Ft. Douglas shall be aluminum, 16-ft tall x 4.5-in straight fluted with fixture end fabricated to match appropriate fixture fittings, with decorative base covershroud.
- b. Circuit Conductors/Conduit
- i. Circuit conductors shall be 3P, 5W (phases A, B, C, neutral and ground) and extend from the beginning of the circuit through each fixture to the end of the circuit. Minimum conductor size shall be #6 copper with a full-sized neutral and #8 ground.
 - ii. Minimum conduit size for outdoor lighting shall be 1.25-in Schedule 40 PVC.
- c. Fusing
- i. Each fixture shall be specified with fusing inside of the hinged pole base.
 - ii. Fusing shall be provided for each ungrounded conductor.
 - iii. Fusing shall be Cooper Bussman type KTK-6, 6-amp, 600-volt, with a Cooper Bussmann HEB-JJ in-line fuse holder with rubber insulating boots. Crimp style fuses shall not be allowed.
- d. Concrete Bases
- i. Refer to the table below for concrete base height above grade and requirements for a mow strip.

POLE LOCATION	MOW STRIP REQUIRED (6-in W X 3-in D)	BASE HEIGHT ABOVE GRADE (INCHES)
Planting Area	Yes	12.0
Near Sidewalk or Curb (Planting Area)	Yes	12.0
Near Sidewalk or Curb	No	12.0
Parking Lot	No	30.0

- ii. Require the Contractor to install light poles a minimum of 36-in from center of base to edge of from sidewalks to avoid damage by snowplows.
 - iii. Bases in or adjacent to parking areas shall be painted yellow.
- e. Hinged Bases
- i. A hinged base is required for each pole light.
 - ii. The folding direction of each hinged base shall allow for a full 90-degree tilt.
 - iii. Hinge direction shall not be directed onto a slope or into traffic. Coordinate

- hinge direction to allow for future maintainability with minimum interference to landscape, obstacles, pedestrians or vehicular traffic.
- iv. Pole and hinged base shall be either Sterner Lighting by Hubbell Lighting, Inc. or LSI Industries, Inc.
- f. Walkway Lighting Fixtures
- i. All walkway lighting fixtures on the Main Campus and the Health Sciences Campus shall be LED Fixtures.
 - ii. Fixtures shall be Dark-Sky compliant.
 - iii. Approved LED walkway fixtures for the Main Campus and Health Sciences Campus are as follows:
 - (a) Cree – Beta Edge (60 LED, 350mA, 4300k) ARE-EDR-3M-R5-06-D-XX-BK-350- 43k
 - (b) Hubbell – AAL Largent (60 LED, 350mA, 4200k) LVT-T3-60LED-NW-BLK
 - (c) Cooper – Mesa LED (63 LED, 350mA, 4000k) MSA-B03-LED-E1-XX-T3-BK
 - iv. Walkway fixtures on the Ft. Douglas campus shall be a 175 watt, metal halide, acorn type fixture.
 - (a) An approved walkway fixture for the Ft. Douglas campus is the Hadco R52 GANN2XNNG175MH.
 - (b) Approved Equals of other manufacturers will be considered.
 - v. Fixture optics shall typically be IESNA Type II, but shall be designed for the proper application.
 - vi. Specify 277V unless directed otherwise by Facilities Management through the University Project Manager.
- g. Roadway/Parking Lot Lighting Fixtures
- i. All Parking Lot lighting fixtures shall be LED Fixtures
 - ii. Approved LED Parking Lot fixtures are as follows:
 - (a) Cree – Beta Edge (120 LED, 350mA, 6000k) ARE-EDR-5M-R3-12-D-XX-BK- 350
 - (b) Hubbell – AAL Largent (56 LED, 350mA, 5000k) SLVT-T5-56LED-5K-700
 - (c) Cooper – Mesa LED (126 LED, 350mA, 6000k) MSA-B06-LED-5xx-T3-BK- 7060
 - iii. Fixture optics shall typically be Type V (symmetric), but shall be designed for the proper site application.
 - iv. Specify 277V unless directed otherwise by Facilities Management through the University Project Manager.
 - v. All fixtures shall be required to have, 5000-5500K color temperature, and a driver producing 350mA.
- h. Parking Terrace Lighting Fixtures
- i. All Parking Lot lighting fixtures shall be LED Fixtures
 - ii. Approved LED Roadway/Parking Lot fixtures are as follows:
 - (a) Cree – 304 Series, PKG-304-5M-XX-04-X-UL-SV-350-ML
 - (b) Lithonia – D Series, DSXPG LED-30C-350-40K-TM-MVOLT-XXX-PIR360SS- DWHXD
 - (c) Cooper – VPL VALET, VPL-B02-E1-SQ-WH-XX-OSX
 - iii. Fixture optics shall typically be Type V (symmetric), but shall be designed for

- the proper site application.
 - iv. Specify 277V unless directed otherwise by Facilities Management through the University Project Manager.
 - v. Occupancy sensors shall be required as part of the lighting system in all parking terraces.
 - i. Lighting Fixture Product Data Sheets
 - i. The A/E shall submit color catalog descriptions/product data sheets (including fixture materials, dimensions, and maintainability information) both at the Design Development phase submittal and at the Construction Document phase submittal for all exterior lighting fixtures intended for the project.
- B. Raceways to 600 V
 - (1) Conduits and Raceways
 - i. Minimum conduit size for outdoor lighting shall be 1.25-in Schedule 40 PVC.
 - ii. Flexible conduit in lengths greater than six feet shall not be allowed.
 - iii. Recessed lighting systems shall not be wired with permanent flex conduit running from fixture to fixture. This provision shall not be interpreted to exclude properly installed and supported UL listed plug-in wiring systems.
 - b. Fire Alarm Circuits
 - i. For raceways containing fire alarm circuits, all conduit couplings, connectors and junction box covers shall be painted red.
 - c. Signal Conductors (Low Voltage)
 - i. Low voltage signal conductors (30 V/1,000 V.A., or less) and conductors used for mechanical equipment controls shall be run in raceways.
 - d. Security Conductors (Low Voltage)
 - i. Low voltage security conductors shall be specified in conduit. When approved by UCard, security conductors may be routed in a cable tray installed above a UCard approved secured ceiling.
 - ii. Loose routing of security cables shall not be allowed.
- C. Conductors
 - (1) MC Cable is allowed on University facilities except in the following locations: Laboratories, Research facilities or work areas, Mechanical Rooms, and Electrical Rooms. Where allowed, the MC Cable shall be labeled at each junction box, fixture, and receptacle. MC Cable shall not be used to penetrate floors or be encased in concrete.
 - (2) Size/Stranded Requirements
 - a. Minimum size conductors for power and light circuits shall be #12.
 - b. All conductors #12 and larger shall be stranded.
 - (3) Neutrals
 - a. Branch Circuit Neutral Conductors
 - i. Lighting Circuits
 - (4) Splices
 - (5) Color Coding
 - a. Color coding for conductors on University projects shall follow the following table:

CONDUCTOR	208Y/120V System	480Y/277V System
Phase A	Black	Brown
Phase B	Red	Orange
Phase C	Blue	Yellow
Shared/Single Neutral	White	Gray

CONDUCTOR	208Y/120V System	480Y/277V System
Neutral A (dedicated)	White w/Black Stripe	Gray w/Black Stripe
Neutral B (dedicated)	White w/Red Stripe	Gray w/Orange Stripe
Neutral C (dedicated)	White w/Blue Stripe	Gray w/Yellow Stripe
Equipment Ground	Green	Green

D. Grounding

(1) Feeders

- a. 480v Feeders

(2) Panels and Distribution Boards

- a. 480-volt panels and distribution boards shall include a bonded ground bus.
- b. 208-volt panels and distribution boards shall include both a bonded ground bus and an insulated ground bus. The insulated ground bus is intended to provide an isolated ground system for sensitive equipment. Required only if sensitive equipment is included in the programming phase of project.

E. Medium Voltage

(1) General

- a. The University's underground medium voltage (MV) electrical distribution system is sectionalized by load break switches. Extensions to the underground distribution system shall be designed with load break switches described herein, mounted on concrete pads, and enclosed by a block wall with a lockable metal gate. Switches shall not be allowed in manholes.
- b. MV Transformer and Switch Pads on Campus
 - i. All medium voltage transformers and switches shall be located outside buildings on suitable concrete pad.
 - ii. Concrete pad location shall be easily accessible by University maintenance personnel with truck-mounted crane.
 - iii. Transformers and associated switch gear shall be set on concrete housekeeping pads 6-in above ground level.
 - iv. Switches and transformers are to be specified with cabinet locks which will suffice for basic equipment security. Refer to [3.5 E \(2\) c](#) for lock requirements.
- c. Enclosure/Screen Wall (Optional)
 - i. Enclosures and/or screen walls for exterior transformers and switches are optional. The design of the enclosure/screen wall shall be consistent with the architectural design of the adjacent building and/or surrounding environment. Locate the equipment and appropriately screened setting in such a way that it is complimentary to and compatible with its surroundings.

- ii. Enclosure/screening requirements described herein apply to both switches and transformers. Switches may be combined with transformers within the same enclosure or screened setting.
- iii. Design the enclosure/screen wall with accessibility for maintenance and future removal/replacement of the switch and/or transformer.
- iv. Location and screening details shall be submitted for approval during project design to Facilities Management through the University Project Manager.
- v. If the equipment must also be placed within a gated secure enclosure, add the following features:
 - (a) Generally, each unit located within the secure enclosure shall have its own metal access gate facing the unit's primary maintenance access panels.
 - (b) The gate width for each opening shall be sized sufficiently wider than the unit it faces to allow direct removal and replacement of the entire unit.
 - (c) The enclosure and metal gate shall be rugged, maintenance free, designed to discourage entry by the public, and include an appropriate no- maintenance drainage system.
 - (d) Design each gate in the enclosure to be locked according to [3.5 E \(2\)c](#).

(2) Medium Voltage Conductors

a. Cables and Terminations

- i. Medium voltage cables shall be single conductor cable rated to 15.5kV. Conductor shall be stranded, class B annealed copper, covered with an extruded semi-conducting ethylene propylene rubber (EPR) strand screen, 220 mil EPR insulation extruded EPR semi-conducting insulation screen 5 mil bare copper shielding tape with 12-1/2% minimum overlap, 80 mil flame retardant PVC jacket overall, 15kV type ungrounded neutral with 133% insulation level.
- ii. Each cable shall be individually wrapped using fire retardant electric arc proofing tape for its entire length where it is not located inside of a duct bank (i.e., inside each manhole, vault, transformer, switchgear section, etc.).
- iii. Each cable shall be individually mounted to the manhole with Unistrut supports (or equal) using porcelain or ZSI, Inc. Cush-A-Grip cable clamps (or prior approved equal).
- iv. All feeders entering a manhole shall ring the manhole a minimum of 360 degrees prior to terminating onto a switch or exiting the manhole.
- v. Each medium voltage feeder which is part of the main distribution line shall consist of (3) #500MCM 15kV cables with (1) #4/0 THWN Cu ground.
- vi. Each medium voltage feeder branching from the main line to a transformer shall consist of (3) 4/0 15kV cables with (1) #4/0 THWN Cu ground.
- vii. Each ground conductor shall be grounded at each manhole or transformer/switch vault.
- viii. Conductors shall be color coded by phase with colored tape.
 - (a) The University phasing scheme is: Phase A – Red, Phase B –

Yellow, and Phase C – Blue.

- (b) Phase designation shall be provided near each entrance or exit point inside a manhole, vault or pad location, at 10' on center inside a manhole, at any switch section the feeder connects to, and inside the primary compartment of each transformer.
- ix. Feeder Identification Tags
 - (a) Feeder identification tags shall be provided for each cable, attached to phase B using a black weather resistant zip tie, in each manhole or transformer vault.
 - (b) See [3.5.1\(2\)](#) for tag requirements.
- x. Cable terminations shall be molded product, 600A dead break and 200A load break. Splices shall be either heat shrink or cold shrink style.
- xi. Acceptable Manufacturers
 - (a) Cable: Okonite, Kerite Company, General Cable Corporation, and Superior Essex
 - (b) Splices: 3M, Raychem TE
 - (c) Terminations: Thomas & Betts Elastimold, Cooper Power Systems, 3M, and Richards Manufacturing
- b. Solid Dielectric Switch Requirements
 - i. SF6 and oil switches shall not be allowed.
 - ii. New switches shall be 15kV, 600A, pad style with switching contacts contained within a solid dielectric medium.
 - iii. Specify combination of 600A dead break and 200A load break “vacuum fault interrupting” (VFI).
 - iv. Require switch sections with single blade per phase, externally operable, with “quick-make”, “quick-break” mechanism.
 - v. Specify bushings located on the front of each switch section, disconnecting handle mounted on the side.
 - vi. Include overcurrent protected ways with a VFI and electronic controller contained in a submersible enclosure.
 - vii. Require parking stands adjacent to each entry bushing.
 - viii. Specify a window in each section with visible trip flags.
 - ix. Require a disconnect handle in each section with provisions for being locked in the “on” or “off” position using the University of Utah standardized cabinet door lock described below.
 - x. Include contacts for future SCADA switch position monitoring.
 - xi. Specify entry termination(s) suitable for standard 600A dead break molded elbows for incoming and outgoing lines.
 - xii. Require VFI ways with entry terminations suitable for standard 200A load break molded elbows.
 - xiii. Specify that the switch shall be mounted on a stainless steel support structure with adequate seismic bracing.
 - xiv. Require a painted NEMA 3R enclosure.
 - xv. Include additional spare ways for future needs of the campus electrical system.
 - xvi. Acceptable Manufacturers
 - (a) Thomas & Betts Elastimold
 - (b) G & W Electric Company

- (c) Eaton VisoVac Fault Interrupter
 - c. Cabinet Door Standardized Locks
 - i. Specify specific padlocks for each lockable cabinet door. Exterior rated weatherproof industrial grade padlocks shall be ASSA catalog #65190B, #2 padlocks, with re-keyable cores and non-retaining key.
 - ii. All padlocks shall be keyed alike with the University's master electrical key.
 - iii. Require the Contractor to coordinate with Facilities Management Key Shop through the University Project Manager.
 - d. Labels and Identification Tags
 - i. A switch identification tag shall be provided to identify the switch and its service information.
 - ii. See [3.5.1\(2\)](#) for labeling requirements.
- (3) Medium Voltage Duct Banks
- a. Spare Ducts in Medium Voltage Duct Banks
 - i. The A/E's design shall include spare ducts within the duct bank in consideration of future needs of the campus electrical system.
 - b. Assembly Requirements for Medium Voltage Duct Bank
 - i. A duct bank shall be an assembly of conduits with, supports, rebar, etc., encased in concrete and buried as described below.
 - ii. bank (not at building or manhole entries) shall be 5-in Schedule 40 PVC conduits, spaced a minimum of three inches between ducts.
 - iii. Duct bank turns greater than 30 degrees shall require 5-in diameter elbows of either galvanized rigid conduit wrapped with PVC tape, or fiberglass sweep elbows, connected to straight length conduit with smooth transitions.
 - iv. Each conduit in the duct bank at building entry, vault, or manhole entry shall be a 10 ft. length of rigid conduit, wrapped in PVC, connected to up-line conduit with smooth bore couplings, and threaded at the open end. Terminate each conduit opening in the building, vault or manhole with a flush mounted "bell-end" threaded into each conduit opening. Metal bell-ends shall be galvanized, rigid metal, and installed flush in the wall.
 - v. Each duct bank shall have a minimum of two (2) 1-in Schedule 40 PVC conduits located at the top of the duct bank (for future SCADA and 120V power connections in the manhole). Require these conduits to be terminated with a small extension into the manhole to allow for future connection to or extension of the conduit.
 - vi. Rebar in the duct bank shall consist of U-shaped #3 cross rebar installed at 36-in on center along the entire length of the duct bank. The cross rebar shall be pounded a minimum of 12-in into the ground below the bottom of the duct bank.
 - vii. The duct bank shall contain two (2) 4/0 bare copper grounds running throughout its entire length. The ground cables shall be terminated at grounds within each manhole or vault.
 - c. Concrete Encasement
 - i. Concrete encasement shall be a minimum of three inches between conduits, and four inches between conduits and earth.
 - ii. Require the Contractor to either mix red dye in the concrete, or sprinkle red dye on top of freshly poured concrete while still wet.

- d. Soil Cover Requirements
 - i. Coordinate site grading and landscaping to provide a minimum of 36-in cover between finished grade and the top of the ductbank.
 - ii. Require the Contractor to install a yellow metallic locator ribbon during backfill. The locator ribbon shall be placed directly above the centerline of the duct bank and 12-in below finished grade.
 - e. After Installation
 - i. After installation, direct the Contractor to pull a mandrel through each duct to insure that no debris has collected in the duct. The mandrel shall be not less than 12 inches long, and the mandrel diameter shall not be less than 1.5-inch diameter smaller than the duct diameter.
 - ii. Direct the Contractor to insert a full length polypropylene pull rope in each unused conduit, connect a plastic conduit plug to each end of the rope, and seal the plugs to each end of all unused conduits with silicone sealant.
 - f. Labeling Requirements
 - i. Require the Contractor to install a permanent engraved label on each end of the duct bank near the duct bank's placement within the building/manhole/vault.
 - ii. Additionally, the Contractor shall be required to install a permanent engraved label for each conduit leaving the manhole. Specific instructions are provided in [3.5 I \(2\)](#).
- (4) University Manholes (Medium Voltage)
- a. General
 - i. Manholes will be included in the design of the University's underground medium voltage electrical distribution system in accordance with the requirements below.
 - b. Site Location
 - i. The placement of manholes on campus shall be carefully considered with Facilities Management through the University Project Manager.
 - ii. Manhole placement shall include consideration for reasonable pulling tension.
 - iii. Access hatches for manholes shall be located in landscaped areas and not in parking lots and roadways.
 - c. Manhole Size
 - i. University manholes shall be 10-ft wide x 16-ft long x 9-ft high (inside dimensions).
 - d. Manhole Fabrication Requirements
 - i. The manhole shell shall be fabricated with 8-in reinforced concrete walls, roof and floor, either cast in place or pre-cast. Knock out panels shall be provided as needed for the project.
 - ii. Manhole construction shall be suitable for an H20 highway loading.
 - iii. Require a full width lift off panel on the roof for equipment access.
 - iv. The access opening shall be located in the corner of the manhole opposite the location of the medium voltage switch.
 - v. Grade rings are preferred to be poured in place to match existing grade or slope.
 - vi. Specify waterproofing for manhole openings, including the manhole entrance, air vents, etc. Require the Contractor to seal openings, grade

- rings, etc., with Sika “Sikadur Combiflex” sealing system or prior approved equal.
- vii. Each manhole shall have openings for two 12-in Schedule 80 PVC air vents. The vent openings shall be located on opposite walls, one located near the bottom of one short wall, and the other near the top of the opposite short wall.
 - viii. Specify flush mounted cast-in horizontal cable supports, equal to galvanized Unistrut, for the manhole walls.
 - ix. Specify a minimum of (3) evenly spaced rows of Unistrut supports with the lowest support at 12-in above the finished floor of the manhole, and the remaining two installed at 3'-8" and 6'-4" above the manhole floor.
 - x. These Unistrut cable supports shall circle the full interior, on all four walls of the manhole.
 - xi. Each manhole shall have four (4) iron ring pulling eyes cast into the manhole walls, one near the floor of each wall, centered on the wall.
 - xii. Each manhole floor shall be sloped to a grate drain and matching frame in the center which will drain to a rock sump provided under the manhole floor.
- e. Manhole Accessory Requirements
- i. Entry Hatch
 - (a) Specify a 4' x 4' galvanized steel “floor/vault/sidewalk” style hatch with two (2) 2' x 4' doors.
 - (b) Cover and frame shall be 1/4-in galvanized steel.
 - (c) Cover shall be diamond-patterned with a hot-dipped galvanized finish.
 - (d) Specify a formed channel frame with full anchor angle welded around the perimeter, designed for the collection and draining of water. The hatch frame shall have a 1.5-in drain coupling welded under the frame assembly, suitable for connection to an auxiliary drain pipe. The collection system shall be adequately sized to divert storm water or landscape irrigation from entering the manhole.
 - (e) Hatch operators shall be compression springs enclosed in telescopic tubes to provide lift assistance for each cover door. An automatic hold-open arm with grip release handle shall be specified for each door.
 - (f) Specify 3/8-in forged brass heavy duty hinges with stainless steel hinge pins. Hinges shall be recessed into the doors to provide a flush surface.
 - (g) Specify a stainless steel slam lock with fixed interior handle and removable exterior turn/lift handle. The access cover for the exterior handle shall be a screw plug insert which is gasketed and flush with the cover.
 - (h) Require the Contractor to connect a full size drain from the frame drain coupling to a gravel sump (separate from the manhole air vent drywells).
 - (i) The access hatch covers and entire assembly shall be designed to

- withstand an H-20 wheel loading.
- ii. The manhole ladder shall extend from floor to hatch entry point. The ladder shall be all stainless steel, 14" wide, with 1.5-in x 1/2-in runners and 3/4-in knurled risers at 12-in on center. The ladder shall be securely bolted to the structure at the top and bottom of the manhole with stainless steel bolts.
 - iii. Design a full width lift off panel in the manhole roof for equipment access.
 - iv. University manholes shall have two (2) 12-in Schedule 80 PVC air vents attached to opposite short walls.
 - (a) Air vent entries shall be located near the bottom of one short wall, and near the top of the opposite short wall.
 - (b) Each air vent riser shall extend below the manhole wall entry into a gravel drywell (1 cubic yard of gravel). This extension will allow rain and irrigation water flowing down from the topside air vent termination box to bypass the manhole wall entry and continue down into the gravel drywell.
 - (c) The A/E's design shall show the location of the joint air vent termination box. Both air vents shall be routed into a 24-in x 24-in concrete box with a powder coated expanded metal top (color to match or blend with the landscape surroundings). The vents shall extend up into the concrete box 12-in above finished grade, flush with the expanded metal top. The vent outlets and concrete box shall be located in landscaped areas (sidewalks and parking areas must be avoided).
 - v. Include specifications for an appropriate rock sump under the manhole grate drain.
 - vi. In addition to the flush mounted "cast-in" horizontal Unistrut supports, require the Contractor to install vertical, surface mounted, cable supports over the cast-in horizontal supports, equal to galvanized Unistrut. Vertical cable supports shall be installed in a minimum of four (4) columns along each long wall, and two (2) columns along each short wall.
 - vii. Require the Contractor to install a grounding ring, consisting of a 4/0 bare copper conductor, circling the entire manhole. Require the following connections to this ground ring:
 - (a) Two (2) 3/4-in x 10-ft copper clad ground rods located in opposite corners.
 - (b) All Unistrut support racks.
 - (c) Each bell end at each duct bank.
 - (d) Each ground conductor running through the duct bank.
 - viii. Each manhole shall have two (2) evenly spaced, ceiling mounted, vapor tight, wet location, 120V, LED, cast aluminum "jelly jar" light fixtures with cast guard. A light switch, enclosed in a cast iron box with weatherproof flip cover, shall be located near the manhole entrance.
 - ix. Each manhole shall have one (1) 20A, 120V duplex receptacle in a cast iron box with weatherproof flip cover, located on a wall near the top.
 - x. Require the Contractor to install a University furnished manhole identification tag at each manhole. Specific instructions are provided in [3.5 I \(2\)](#).

- xi. Cable entering/leaving the manhole shall enter/exit through 10-ft rigid conduit with bell ends at the manhole interior wall.
- xii. Require the Contractor to ring the manhole with each cable before terminating.
- xiii. Support each cable in the manhole at Unistrut cable supports with rubber cush- grips.
- xiv. Specify and/or detail all required safety connections (i.e., deadbreak connectors with cable clamps, drain wire, neutral grounds, etc.).

F. Motor Controllers

- a. Specify wiring standard to be Class-B.
- b. Require the Contractor to install a permanent engraved label(s) to clearly identify each controller and any spares/spaces. Specific instructions are provided in [3.5 I \(2\)](#)
- c. Specific VFD Requirements
 - i. Each drive shall be specified as a complete system and shall be assembled in a single NEMA rated enclosure suitable for the conditions in which it is to be located.
 - ii. Specify remote signal connection terminals (0-10 VDC = 0-100% speed, or, 4-20 mA = 20-100% speed). Label the VFD cabinet specifying which control signal is used.
 - iii. AC line reactors shall be specified.
- d. Inverter Protective Features/Required Alarms
 - i. Overcurrent Shut-Off
 - ii. Regenerative Overvoltage
 - iii. Electronic Thermal Protector
 - iv. Heatsink Overheat
 - v. Instantaneous Power Failure
 - vi. Ground Fault
- e. Door Mounted Operator Devices
- f. Required Door Mounted Operator Controls
 - i. Hand/Off/Auto switch
 - ii. Local/Remote switch
 - iii. Frequency Setting Speed Pot
 - iv. Power On light
 - v. VFD Enable light
 - vi. VFD Fault light
 - vii. External Fault light (safeties interlock)
 - viii. Bypass switch (for motors over 5-hp)
- g. Required Termination Points on Field Connection Terminal Strip
 - i. Safeties Interlock (N.C. contacts located remote)
 - ii. Remote Start/Stop Contact (N.O. contacts located remote)
 - iii. Remote VFD Fault Contacts (N.C.)
 - iv. Remote VFD/Bypass Enable Contacts (N.O.)
 - v. Remote Electronic Signal Input
- h. Environmentally Controlled Room
 - i. Each motor controller shall be installed inside the building in an environmentally controlled room. Written approval shall be obtained from

Facilities

Management for any exterior installation, including controllers serving rooftop equipment.

- i. VFD Local Vendor Requirements
 - i. N/A
- ii. Label Requirements
 - i. Require the Contractor to install a permanent engraved label mounted to the exterior face of the controller. Specific instructions are provided in [3.5 I\(2\)](#)

(2) VFD Manual Bypass

- a. A manual isolation bypass switch shall be specified for VFD's rated over 5-hp, where motor redundancy is not provided. The manual isolation bypass switch shall be on the line side of the inverter allowing maintenance operations to be safely performed while the system is operating in bypass mode. The bypass shall include minimum of two (2) mechanically interlocked contactors.

(3) Combination Starters

- 1. Starters shall be specified with hand-off-auto selector switch.

(4) Electronic Solid State Starters (where applicable)

- a. An electronic soft start system shall typically be specified for each motor 10HP and above. Soft start systems shall incorporate the features of the combination starter in addition to the following:
 - i. 18 Pulse converter design to maintain minimal AC line distortion.
 - ii. Adjustable ramp start of 0.5-180seconds.
 - iii. Adjustable current limit of 0-85% of locked rotor current.
 - iv. Adjustable soft stop from 0-60seconds.
 - v. Electronic timing relay adjustable from 0.1-60seconds.
 - vi. Automatic fault isolation.
 - vii. Elapsed time meter located on the front door of the starter.

G. Electrical Distribution

(1) General Requirements

- a. Overcurrent and Ground Fault Protection
 - i. Electrical service to all University buildings shall be 120/208V, 3P, 4W or 277/480V, 3P, 4W, or both.

(2) Arc Flash Study

- a. The A/E shall perform or model an arc flash study as part of its design services to meet requirements of NFPA 70 and NFPA 70E.
- b. Results of the study shall be submitted to the University, and appropriately applied to the review documents.
- c. The arc flash analysis shall include the following at each distribution bus:
 - i. Bolted Fault Current
 - ii. Arc Fault Current
 - iii. Protective Device Settings
 - iv. Protective Device Characteristic and Arc Fault Duration

- v. System Voltages and Equipment Class
 - vi. Working Distances
 - vii. Calculated Incident Energy
 - d. Calculated Arc Flash Protective Boundary
 - i. The results of the study shall be used to specify appropriate labels specific to each panel, identifying the ARC flash hazard class based upon NFPA 70E.
- (3) Transformers
- a. Distribution Transformers for University Buildings
 - i. Transformers shall be pad mounted on the exterior of the building, see [3.5 E \(1\) b](#) for additional requirements.
 - ii. Transformers shall meet the following requirements as a minimum:
 - (a) All copper windings with a delta primary and wye secondary.
 - (b) FR3 insulation fluid (vegetable oil based) with nitrogen blanket.
 - (c) Four (4) 2-1/2% full capacity primary winding taps, with two above and two below the rated primary voltage with an externally operated de-energized tap changer.
 - (d) Transformer primary shall have two (2) sets of three (3) 200A bushing wells (loop feed style) that will accept load break elbows or lightning arrestors. Lightning arrestors shall be provided and installed on second set of bushings.
 - (e) Each transformer shall be capable of being readily and easily locked. See [3.5 E \(2\) c](#) for lock requirements.
 - (f) Transformer sound levels shall comply with NEMA Standard TR.
 - (g) For transformers larger than 750 KVA/208-240V secondary, and 1500 KVA/480V secondary, the low voltage bushings shall be wall mounted with additional insulated support for the bushings.
 - iii. Transformers shall have a 12470V primary rating. If fed from an existing feeder that is not on the new campus standard 12470V system, the transformer shall be specified to be dual rated to allow for future transition to 12470V.
 - iv. Each transformer is to be protected on the primary side by a separate solid dielectric vacuum fault interrupting switch. The specified VFI shall coordinate with the existing University electrical distribution, and settings shall be provided to the Contractor.
 - v. Require the Contractor to install a permanent engraved label mounted to the exterior of the transformer. Specific instructions are provided in [3.5 I \(2\)](#)
 - vi. Acceptable Manufacturers
 - (a) Cooper Power Systems
 - (b) GE Energy
 - (c) Eaton Corporation Cutler-Hammer
 - (d) Schneider Electric Square D
 - (e) MGM Transformer Company
 - b. Step Down Transformers for University Buildings
 - i. When electrical power is needed at a voltage other than that provided by the building's electrical service, the needed voltage may be provided by

including a step down transformer in the system design.

- ii. Step down transformers shall be specified with the following requirements:
 - (a) Dry-type, K rated.
 - (b) Pad mounted.
 - (c) Copper windings.

 - (d) Specify a K-20 rating with 200% neutral for transformers smaller than 300kVA intended to handle nonlinear loads.
 - (e) Specify a K-13 rating with 200% neutral for transformers 300kVA and above intended to handle nonlinear loads.
 - (f) Temperature rise rating shall be 115 degrees through 15kVA and 150 degrees for 30kVA and larger.
- iii. Require the Contractor to install a permanent engraved label mounted to the exterior of the transformer. Specific instructions are provided in [3.5 I \(2\)](#)

(4) Switchboards and Distribution Boards

- a. Switchboards/distribution boards for University projects shall be specified with:
 - i. Copper busing.
 - ii. CU/AL rated lugs.
 - iii. Circuit breaker type.
 - iv. Fully rated.
 - v. Minimum of 25% space capacity.
- b. For remodeling projects, match new switchboards and distribution boards to the manufacturer/style of existing units in the building.
- c. Labeling Requirements
 - i. Specify a permanent engraved label for all switchboards mounted on the outside face of switchboard.
 - ii. Specify a permanent engraved label to clearly identify each switchboard breaker and spare/space.
 - iii. Specific instructions are provided in [3.5 I \(2\)](#).

(5) Panel Boards

- a. University panel boards shall be specified with:
 - i. Copper busing. Aluminum alloy bus bar is allowed in Building Main Distribution Panels rated 800 amps and above.
 - ii. CU/AL rated lugs.
 - iii. Circuit breaker type with bolt-on style breakers.
 - iv. Fully rated.
 - v. Minimum of 25% space capacity.
 - vi. Equipment and isolated ground bus.
- b. For remodeling projects, match new panel boards to the manufacturer/style of existing units in the building.
- c. Panel board covers shall be hinged door-in-door style. Each door shall have a flush, stainless steel cylinder lock with catch and coil spring loaded door pull. All panels shall be keyed alike, but inner and outer doors shall not be keyed alike.
- d. Panel boards shall have a sufficient number of spare conduits stubbed into ceiling spaces (or alternate locations approved by the University Project Manager) to allow

- for full future utilization of the spare capacity available in the panel board.
- e. Panel boards shall have sufficient space inside the cabinet for future cable pulls.
 - f. Provide a permanent engraved label for all panel boards mounted inside the door for flush panels and on the outside face of the door for surface panels. Specific instructions are provided in [3.5 I\(2\)](#).
- (6) Disconnecting Means for University Projects
- a. Equipment disconnecting means (thermal switch, disconnects, fused disconnects, circuit breakers, etc.) are to be provided at the unit or immediately next to the unit served. Installation of the disconnecting means at a remote location from equipment, or using a circuit breaker at the power panel as disconnecting means for equipment are not acceptable installation methods.
 - b. Final location of the equipment disconnects and controllers (air handlers, condensing units, exhaust fans, roof top units, pumps, etc.) are to be coordinated with the Facility Operations staff electrical engineer and Electric Shop through the University Project Manager prior to issuing construction documents.
 - c. The A/E's design shall facilitate compliance to OSHA CFR 1910.147, Control of Hazardous Energy (Lock Out Tag Out).
- (7) Outlets
- i. Meet the latest EPA Tier Standard.
 - ii. For 'research critical' buildings, design the transfer system such that operation of the secondary transfer switch will easily protect non-life safety research processes/systems during the monthly generator test.
 - b. Require generator emission data to be submitted through the University Project Manager to the University Department of Occupational and Environmental Health & Safety for review and generator approval.
 - i. During design, coordinate early with the University Project Manager to establish a timeline and application/submittal requirements for generator approval by the jurisdiction having authority.
- (8) Uninterruptible Power Supplies for University Projects
- (9) Miscellaneous Electrical
- a. Building Clock Systems for University Projects
 - i. A self-correcting clock system will be installed in University buildings either as called for in the project program, or to extend/replace existing building clock systems.
 - ii. Clocks and Clock System Controls
 - b. Communication Protocols
 - i. Data communication protocol for integration of electrical systems with the building management system shall be compatible with BACnet data communication protocol. This requirement shall be applicable to all electrical systems, including, but not limited to, lighting control systems, non-local UPS systems, emergency generators, transfer switches, paralleling switchgear, power monitoring, power metering, VFDs, motorized shade controllers, etc.
- (10) Structured Cabling
- a. Refer to [3.11 Communications and Security Wiring Systems](#).
- (11) Fire Alarms

- a. General
 - i. Fire alarm systems shall be fully addressable, analog and shall operate as non-coded, continuous sounding systems.
 - ii. All necessary provisions shall be made in the design of the fire alarm system to allow for automatic reporting of all alarms from the project fire alarm system to the remote station receiving console in University's Public Safety Building (Bldg 301).
- b. Compatibility
 - i. All equipment, devices and installations shall be compatible with the existing system of operation.
- c. Approved Manufacturer/Installer
 - i. Fire Alarm System
 - (a) The only approved manufacturer shall be FCI (Honeywell Gamewell Fire Control Instruments, model E3 Series or S3 Series). No other model or manufacturer will be approved.
 - ii. Fire Extinguisher Electronic Notifying Pressure Switch Monitoring System
 - (a) Specify an electronic notifying pressure switch fire extinguisher monitoring system. The approved manufacturer shall be MIJA, Inc., model en.Gauge. No other manufacturer will be approved.
- d. Fire Extinguisher Monitoring System
 - i. During design, coordinate with the University Fire Marshal through the University Project Manager to determine type of fire extinguishers (A, B, C, D, CO₂, Halon, etc.,) to be used in the project.
 - ii. For new buildings, design a hard wired fire extinguisher monitoring system, supervised through the building's fire alarm system.
 - iii. The system will signal an alert when the portable fire extinguisher falls below a preset, specified pressure level, removed from its designated location, when access to the extinguisher is obstructed or when the battery voltage drops to a preset rating. The system shall meet all code requirements and listed by Underwriters Laboratories, Inc.
 - iv. For existing buildings provide fire extinguishers with wired monitoring systems.
- e. Control Panel General Requirements
 - i. The fire alarm control panel shall detect the operation of any signal initiating device, display the description of the device and the area of the alarm, and print out the alarm type, location, time, and date.
- f. Required System Features
 - i. Digital transmitter with terminals and other necessary hardware/software to permit the transmission of trouble and alarm signal via AES radio and FocalPoint Gateway via UIT network. Two active Cat6 connections are required from main fire alarm control panel to a network switch located in the building.
 - (a) Gamewell-FCI Part: FPT-GATE-3 & ANX-SR
 - (b) A key operated "Drill Switch" to simulate the operation of an initiating device. The switch shall not trip the device which transmits a signal to the fire department, operates elevator return systems or operates fire doors.
 - (c) Fire alarm panels shall be red or black, baked enamel, lockable with a

default Gamewell-FCI PK625 Key, 16-gauge steel, with hinged door cabinets

- (d) Unless otherwise specified, minimum wire size shall be 16-gauge for audible alarm circuits, and 18-gauge for signal initiating circuits.
- (e) A complete system test, including all connections into the fire alarm panel, comprehensive operational review, and testing of all fire alarm devices and wiring shall be accomplished by a representative of the equipment supplier or manufacturer, qualified by the manufacturer to perform such work.
- f. Labeling
 - i. Provide permanent engraved labels at each fire alarm control, notification appliance (NAC), power supply, transponder, and speaker system panel. Specific instructions are provided in [3.5.1\(2\)](#)
 - ii. Provide self-adhesive labels for all initiation and notification devices. Specific instructions are provided in [3.5.1\(3\)](#)
- g. Final Inspection
 - iii. Upon completion of the work, require the Contractor to request a final inspection through the University Project Manager to the University Fire Marshal and University Building Official. During the final inspection, all fire alarm devices shall be tested by the Contractor and witnessed by these University officials.
- h. Warrantee Period
 - i. Specify that the accepted fire alarm system shall carry a full three year parts and labor warrantee. Require the Contractor, the equipment supplier, and the installer to provide continued emergency response services (responding within four hours of any reported system failure) through the full term of the warrantee.
- 1. For Miscellaneous Systems refer to [3.11 Communications and Security Wiring Systems](#).
- ii. Labeling & ID Tags for Medium Voltage Systems
 - 1. General Requirements
 - a. The A/E shall include the information provided below in project electrical specifications and drawings, requiring the Contractor to provide and install appropriate labels and tags throughout the project's electrical system.
 - b. The purpose of the labels and tags is to provide clear indications of the function of each item, the loads served, routing information, etc., for primary and secondary elements comprising the electrical system.
 - 2. Permanently Engraved Lamicoid Nameplates
 - a. Lamicoid nameplates shall be three-ply plastic, 1/16 inch thick. Letters shall be formed by engraving into the outer colored ply, exposing the white or black center-ply. Lettering shall be a minimum of 5/8-inch high, except as noted in individual sections.

LAMICOID NAMEPLATE COLORS		
NAMEPLATE	OUTER PLY	CENTER PLY (Lettering Color)
Master Nameplate	Black	White
Normal Power	Black	White
Emergency Power	Red	White
UPS Power	Blue	White
Medium Voltage	Yellow	Black

- b. Provide permanently engraved nameplate labels/tags for the master nameplate, for each manhole, duct bank, all distribution equipment, devices, etc., listed below as well as all other similar equipment. Other electrical sections in this supplement may have additional labeling requirements.
 - i. Each label shall include the arc flash hazard class based upon NFPA 70 E, where applicable.
- c. Master Nameplate
 - i. Provide a permanently engraved lamicoïd master nameplate at the main distribution location affixed with double sided adhesive tape covering the back of the nameplate, to identify the project, the engineer and the installation date.
- d. Duct Bank Identification Nameplates
 - i. Permanently engraved lamicoïd nameplate labels must be placed adjacent to each entering/leaving duct at the duct banks in the man hole.
 - ii. Labels are to be 3-in x 5-in yellow with black engraved letters.
 - iii. Labels are to include a 1/4-in hole in each corner. Each label shall be affixed to the wall using plastic anchors and screws.
 - iv. Lettering shall indicate the conduit's next destination point or last departure point (e.g., To MH #123, From Pad #123, To Vault #123).
 - v. Example: Duct Bank Identification Nameplate

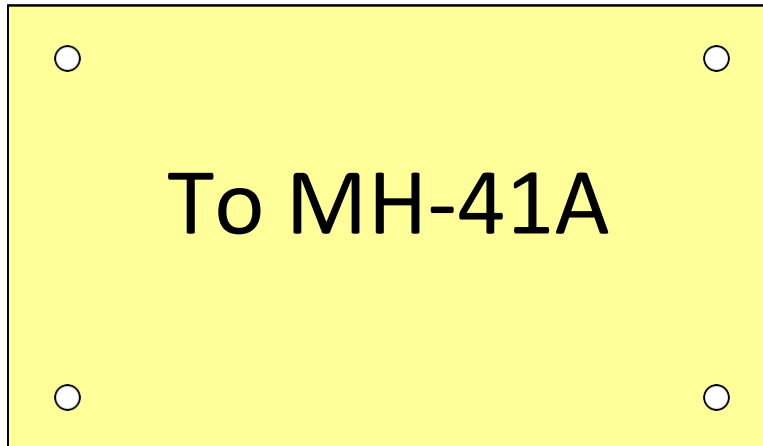

- e. MV Cable
 - i. Feeder identification tags shall be attached to each feeder near entrance or exit points inside manholes, vaults or pad locations; at any switch section the feeder connects to; and, inside the primary compartment of each transformer.
 - ii. Lamicoid tags shall be 2.5-in x 2.5-in x 1/16-in, diamond orientation (not a square), and shall be yellow with black engraved letters.
 - iii. Lettering shall be 3/8-in high, centered, and shall indicate the substation and feeder number.
 - (a) Example: F-71 (indicating substation 7, feeder#1)
 - (b) Example: RB F-10-2 (indicating the Red Butte Substation, Substation 10, feeder #2).
 - iv. Lamicoid tags shall be attached to phase B using a black weather resistant zip tie. Tags are to include a 1/4-in hole in the top corner to allow attachment by means of the zip tie.
 - v. Tags shall be located where lettering will be readily visible. The zip tie attachment must not be pulled too tight, allowing for minor adjustment by maintenance personnel.
- f. MV "Switch Cabinet" Identification Nameplates
 - i. Permanently engraved lamicoid nameplate labels shall identify each switch cabinet.
 - ii. Labels are to be 3-in x 5-in yellow background with black engraved letters.
 - iii. Each label shall be affixed to the cabinet with double sided adhesive tape covering the back of the nameplate.
 - iv. Each nameplate shall include the pad number, switch number, the building name and number served by the switch, and voltage.
 - v. Example: MV Switch Cabinet Identification Nameplate

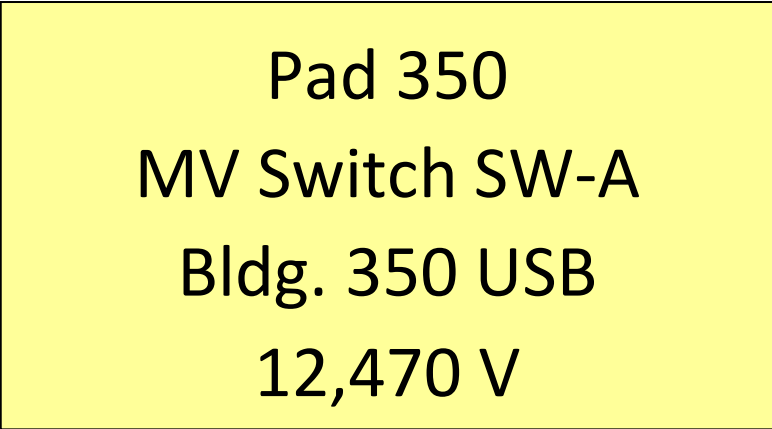

- g. MV “Switch” Identification Nameplate
 - i. A permanently engraved lamincoid nameplate label shall:
 - (a) Identify the device the switch will operate; or,
 - (b) Identify the destination manhole, vault, or pad number; the switch number; and, section it serves; or,
 - (c) Identify the destination switch and the section the feeder serves.
 - ii. Labels are to be 3-in x 5-in yellow background with black engraved letters.
 - iii. Each label shall be affixed to the switch with double sided adhesive tape covering the back of the tag.
 - iv. Example: MV Switch Identification Nameplate:

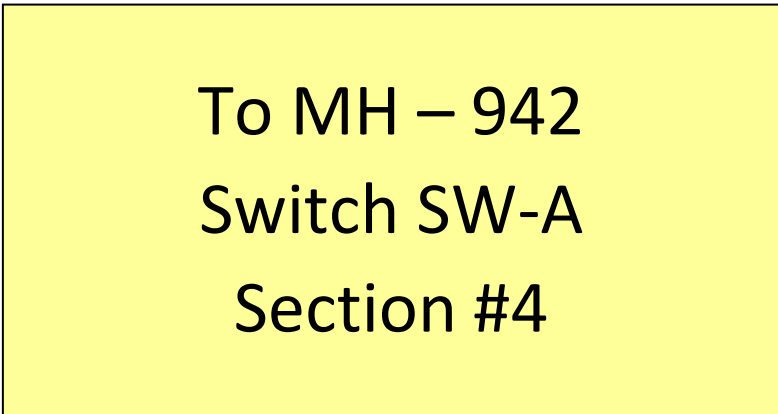

- h. Distribution Transformer Identification Nameplates
 - i. Permanently engraved lamincoid nameplate labels shall identify each transformer and its location.
 - ii. Labels are to be 3-in x 5-in yellow background with black engraved letters.
 - iii. Each label shall be affixed to the cabinet exterior with double sided adhesive tape covering the back of the nameplate.
 - iv. Each nameplate shall designate the pad number (same as the building number), transformer number, primary and secondary voltages, KVA rating, and the building name/number served by the transformer.

v. Example: Transformer Identification Nameplate

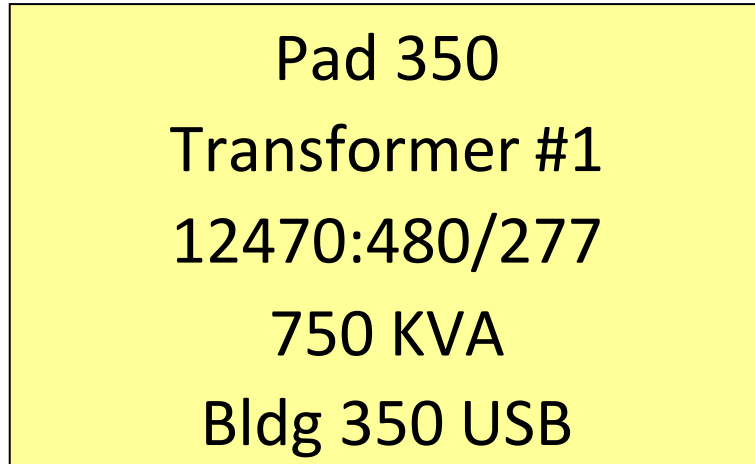

i. Step Down Transformer Identification Nameplate

- i. A permanently engraved lamicoid nameplate label shall identify each transformer.
- ii. The nameplate shall be 3-in x 5-in with yellow background and black engraved letters.
- iii. Each label shall be affixed to the cabinet with double sided adhesive tape covering the back of the nameplate.
- iv. The nameplate shall designate the transformer, electrical source feeding the transformer, load supplied, size (kVA), and the primary and secondary voltages.
 - (a) Example: Transformer T-1, Source PH1-1, 3, 5; Load PL1, 150kVA, 480:208/120.

j. Manhole Identification Nameplates

- i. Manhole identification nameplates will be supplied to the Contractor by the Facility Operations Electric Shop through the University Project Manager.
- ii. A manhole identification nameplate is required for each manhole, installed at existing and new manholes associated with the project.
- iii. The nameplate shall be mounted on the north side of the concrete ring as you enter the manhole, and shall be easily visible both from ground level outside and from the floor level inside the manhole. This standard will be followed for all manholes on campus, and provides a means for convenient orientation by observing the nameplate in a known location, either while entering or when established inside the manhole.
- iv. The nameplate shall be affixed to the concrete ring using plastic anchors and screws.

k. Switchboards, Distribution Boards, and Panel Boards

- i. Permanently engraved lamicoid labels are required for each switchboard, distribution board, and panel board, as described below.
- ii. For normal power, labels are to have a black background with white engraved letters.

- iii. For emergency power, labels are to have a red background with white letters.
 - iv. Each label shall be affixed to the cabinet in a readily visible location with double sided adhesive tape covering the back of the nameplate.
- I. Switchboard Label
 - i. The switchboard label shall include the switchboard name, electrical source feeding the switchboard, voltage, size (amps), number of phases, number of wires, and AIC rating.
 - (a) Example: MDP1, Transformer-1, 480V, 3P, 4W, 65kAIC
 - ii. If the switchboard contains a main building disconnect, this shall be included on the label.
 - (a) Example: Main Building Disconnect 1 of 2
 - m. Switchboard Breaker and Spare Space Labels
 - i. Switchboard breaker and spare space labels shall be installed to clearly identify each switchboard breaker and spare/space. Each label shall include the breaker number and the load served.
 - (a) Example: MDP1-1, Panel PH1
 - ii. For spare/space, the label shall indicate “spare” as well as the size in amps and phase.
 - (a) Example: Spare, 200A, 3P
 - (b) Example: Space, 400A max, 3P
 - n. Panel Board Labels
 - i. Panel board labels shall be mounted inside the door for flush panels, and on the outside face of the door for surface panels. The label shall include the panel name, source feeding panel, voltage, size (Amps), number of phases, number of wires, AIC rating, and the arc flash hazard class based upon NFPA 70E.
 - (a) Example: PH1, MDP1-1, 277/480V, 225A, 3P, 5W, 42kAIC, Arc Flash Class 1
 - ii. Use the following labeling scheme for panel boards

LEVEL	UPS/EMERGENCY POWER	VOLTAGE LEVEL	PANEL SEQUENCE
0 (Level 0/Basement)	U (UPS)	H (277/480 V)	1
1 (Level 1)	E1 (Emergency Life Safety – Connected to ATS-1)	L (120/208 V)	2
2 (Level 2)	E2 (Critical Emergency – Connected to ATS-2)		3
3 (Level 3)	E3 (Optional Emergency – Connected to ATS-3)		4
etc.	etc.	etc.	etc.

- iii. Examples:
 - (a) 2E1L1 – Level 2, Emergency Life Safety Power, 277/48120/208V0V, 1st panel on level 2

- (b) OUL6 – Level 0, UPS Power, 120/208V, 6th panel on level 0
- (c) 1H2 – Level 1, 277/480V, 2nd panel on level 1
- (d) 3L11 – Level 3, 120/280V, 11th panel on level 3
- o. Motor Control Centers (MCC), Motor Controllers
 - i. Permanently engraved 3-in x 5-in lamicoid labels are required to identify the MCC and each controller.
 - ii. For normal power, labels are to have a black background with white engraved letters. For emergency power, labels are to have a red background with white letters.
 - iii. Each label shall be affixed to the cabinet in a readily visible location with double sided adhesive tape covering the back of the nameplate.
 - iv. MCC labels shall identify the MCC, source feeding the MCC, voltage, size (amps), number of phases, number of wires, and AICrating.
 - (a) Example: MCC#1, MDP1-2, 600A, 3P, 4W, 42kAIC
 - v. Where applicable, the label shall also include the load served and the breaker size
 - (a) Example: EF-1, 125A
 - vi. For spare/space, the label shall indicate the size in amps and phase
 - (a) Example: Spare, 200A, 3P
 - (b) Example: Space, 400A max, 3P
- p. Variable Frequency Drives (VFD)
 - i. Permanently engraved 3-in x 5-in lamicoid labels are required to identify the equipment controlled, electrical source feeding the controller, voltage, number of phases, disconnect and fuse sizes in amps where applicable, and equipment horse power.
 - (a) Example: AHU-1, PH1-1,3,5, 480V, 3P, 200A/150A fuse, 75HP
 - ii. Additionally, require a second label on the VFD cabinet specifying which control signal is used.
 - iii. For normal power, labels are to have a black background with white engraved letters. For emergency power, labels are to have a red background with white letters.
 - iv. Each label shall be affixed to the cabinet in a readily visible location with double sided adhesive tape covering the back of the nameplate.
- q. Fire Alarm Control Panels (FACP), Fire Alarm Notification Appliance Circuit Panels (NAC), and Other Fire Alarm Panels/Cabinets
 - i. Permanently engraved 3-in x 5-in lamicoid labels are required to identify each panel. Require labels for each fire alarm control, notification appliance (NAC), power supply, transponder, and speaker system panel.
 - ii. For normal power, labels are to have a black background with white engraved letters. For emergency power, labels are to have a red background with white letters.
 - iii. Each label shall be affixed to the cabinet in a readily visible location with double sided adhesive tape covering the back of the nameplate.
 - iv. Each label is to include the panel name and the source feeding the panel
 - (a) Example: FACP, PL1-1 or NAC-1, PL1-3

- r. Additionally, provide permanently engraved lamicoide nameplate labels/tags for the following, as well as all other similar electrical devices and equipment.
 - i. UPS and Surge Protection Devices
 - ii. Safety Disconnects
 - iii. Generators
 - iv. Automatic Transfer Switches
 - v. Paralleling Switchgears
 - vi. Electrical Contactors and Relays
 - vii. Lighting Control Panels, Lighting Contactor Panels, Dimming Panels
 - viii. Time-clocks
 - ix. Security Panels
 - x. Power Supplies
- (3) Self-Adhesive Labels
- a. Specify self-adhesive labels for the devices and equipment as required.
 - b. Self-adhesive labels shall have black lettering with a clear (see through) background, and a self-adhesive sticky back.
 - c. Each label shall identify the applicable circuit number feeding the device. The label shall also display "EMERGENCY" or "UPS" as applicable next to the circuit number for devices fed from Emergency or UPS power.
 - i. For example, a receptacle fed from circuit 2 in panel 1P1 would read "1P1-2" on the label.
 - d. Require the Contractor to apply self-adhesive labels to the following devices and equipment, and all similar equipment.
 - i. Thermal Switches and Manual Starters
 - ii. Power Outlet Receptacles
 - iii. Light Switches
 - iv. Wall Mounted Occupancy Sensors
 - v. Wall Mounted Time Switches
 - vi. Dimming Switches and Wall Mount Dimming Controllers
 - vii. Fire Alarm Initiation Devices (Smoke Detectors, Heat Detectors, Pull Stations, etc.) and Fire Alarm Notification Devices (Horns, Strobes, etc.).
 - (a) Require self-adhesive labels for all initiation and notification devices.
 - (b) Each initiation device label shall indicate the addressable node, the addressable loop number, device type (S=sensor, M=monitor), and device number (i.e., N1-L1S001, N1-L2M001).
 - (c) Each notification device label shall indicate the device type (S=speaker, L=strobe), the circuit number, and the device number (i.e., S1-1 or L1-2).
- (4) Handwritten Labeling
- a. Specify legible handwritten labeling for all junction boxes containing power and fire alarm wiring.

- b. Require the Contractor to use a permanent chisel tip black marker, and write the required information in a neat and clearly legible manner clearly visible from the floor.
 - c. Label each junction box with the applicable circuit number(s) for the cables contained within.
- (5) Word Processor Generated Branch Panel Schedules
- a. Specify typewritten branch panel schedules incased in clear, transparent covers for each branch panel.
 - b. Require the Contractor to label every breaker or available space.
 - c. Actual room designations (room name and room number) assigned by the University shall be used. Instruct the Contractor to verify room designations. Room identifiers on project drawings may be different than final room assignments.
 - d. When the project requires changes in, or additions to existing panels, distribution boards, etc., provide new schedules and labeling to accurately reflect the changes.

3.2 Mechanical – General

A. Standards

- (1) Compliance Verification in Operation and Maintenance Manuals

B. Criteria

- (1) Outside Design Temperatures
- (2) Site Elevation
 - a. Equipment selections shall account for a site elevation of 4,750 feet (1,500 meters) above sea level, and equipment schedules shall indicate "sea level" capacity.
- (3) Indoor Design Temperatures
- (4) Ventilation Requirements
- (5) Heating Systems
- (6) Refrigerant Relief Piping
 - a. Evaporator coils located near heating coils; and, pressure relief devices and fusible plugs shall have relief piping, sized and routed per the requirements of ASHRAE Standard 15 "Safety Code for Mechanical Refrigeration".
- (7) Mechanical Rooms as Return Air Plenums
- (8) Start-Up Strainers
 - a. When start-up strainers are replaced with specified strainers prior to test and balance, require the Contractor to place each removed start-up strainer near the pump or Y-strainer it served for inspection by the University of Utah Facility Operations staff.
- (9) Factory Witness Tests of Equipment
 - a. The University Project Manager shall determine the need for a factory witness test of major equipment items.
- (10) Equipment, Pipe and Duct Identification
 - a. All plumbing, heating, air conditioning, automatic temperature control equipment (excluding thermostats and relays), and distribution systems shall be labeled. Electrical switches and starters for mechanical equipment shall also be labeled.
 - i. Equipment labels shall be 1/8-in thick plastic black face with white engraved lettering 3/16-in high or larger, and shall be attached securely.
 - (a) All labels associated with high temperature piping and in high temperature equipment room shall be as required in valve section below.

No non-metal labels allowed.

- ii. Equipment nameplates shall include the following minimum information:
 - (a) Plan identification
 - (b) Capacity specified at designed operating conditions
 - (c) Actual capacity as balanced at site operating conditions
 - (d) Area or zone served
- iii. All valves, regardless of size, shall have brass tags at least 1-in by 3-in in size and 0.051 inches thick. Lettering on the tag shall be engraved at least 1/8-in high. Each valve on the drawing shall be identified separately, and valve tags shall match the drawing identification.
- iv. Valve tags shall be connected to valve stems by steel rings and include the following minimum information:
 - (a) Plan identification
 - (b) Normal position
 - (c) Duty
 - (d) Area served
 - (e) Valve type
- v. Additionally, heating water valves, steam valves, and all valves located in the secondary (low pressure) side of HTW heat exchangers shall include the manufacturer, size, grade, and pressure-temperature service rating.
- b. All accessible duct and piping shall be color coded and identified with wording and arrows every 50-feet, at each riser, at each junction, at each access door, and where required to easily identify the medium transported.
- c. Duct and piping systems shall be identified by:
 - i. Background color
 - ii. Lettering color, and
 - iii. Flow direction arrow
- d. Duct and piping background color shall be applied to all exposed piping (either over bare pipe or the insulation) in mechanical rooms. Identifying lettering and arrows shall then be added as indicated above, and as necessary to be visible from anywhere in the room.
 - i. For duct in mechanical rooms, chases, and other exposed areas, as well as piping routed in other exposed areas such as chases, background color shall be applied in a two foot (2'-0") wide band with identifying lettering and a flow direction arrow.
 - ii. Background and lettering shall be semi-gloss enamel paint. The colors specified herein shall not vary. The table below lists the closest matching Pantone® color code for reference.

COLOR	PANTONE® MATCHING SYSTEM COLOR
Safety Red	485 C
Safety Orange	152 C
Safety Yellow	109 C
Safety Green	3415 C

Safety Blue	2945 C
-------------	--------

COLOR	PANTONE® MATCHING SYSTEM COLOR
Safety Purple	259 C
Brown	168 C
Gray	430 C
Black	Black
White	White

- iii. Identifying lettering shall be painted or stenciled on duct or pipe over the background color. Self-adhesive or glue-on type labels are acceptable. Letters shall be 2" high for duct and larger piping 3" or more, 1" high for 1-1/4" to 2-1/2" pipe, and 1/2" high for 1" pipe and smaller.
- iv. Arrows to indicate direction of flow shall be painted over the background color in the same color as the lettering. The arrow shall point away from the lettering. On duct and large piping 3" or more in diameter, the "shaft" of the arrow shall be 2" long and 1" wide. Smaller piping, 2-1/2" or less, shall have arrows with a shaft 1/2" wide and 2" long. Use a double-headed arrow if the flow can be in either direction.
- v. Piping and duct shall be identified with the following colors:

MEDIUM IN PIPE OR DUCT	BACKGROUND COLOR	IDENTIFYING LETTERING	LETTERING COLOR
COMPRESSED AIR			
Lab Service	Gray	Compressed Air	Black
Automatic Controls	Gray	Control Air	Black
COMPRESSED GAS			
Hydrogen	Brown	Hydrogen	Black
Natural Gas	Brown	Natural Gas	Safety Yellow
Nitrogen	Gray	Nitrogen	Black
Oxygen	Brown	Oxygen	Black
REFRIGERANT			
Freon	Black	Freon	White
STEAM – LOW PRESSURE (0 – 15 PSIG) (NOTE: NO BANDS FOR LOW PRESSURE)			
Steam – Low Pressure	Safety Orange	Low-Press. Steam	Black
STEAM – HIGH PRESSURE (OVER 15 PSIG) (NOTE: TWO BLACK BANDS REQUIRED FOR HIGH PRESSURE)			
Steam – High Pressure	Safety Orange	Hi-Press. Steam	White
VACUUM			

MEDIUM IN PIPE OR DUCT	BACKGROUND COLOR	IDENTIFYING LETTERING	LETTERING COLOR
Vacuum	Gray	Vacuum	Black
WATER **NOTE: DIRECTIONAL ARROWS ARE REQUIRED ON HTW PIPING.			
Boiler Blow-Off	Safety Yellow	Blow-Off Water	Black
Chilled Water Supply	Safety Blue	Chilled Water Supply	White
Chilled Water Return	Safety Blue	Chilled Water Return	White
Condenser Water Supply	Safety Blue	Cooling Water Supply	White
Condenser Water Return	Safety Blue	Cooling Water Return	Black
Condensate Return (Note: One white band is required for Steam Condensate Return.)	Safety Orange	Condensate Return	Black
Cold Water (Potable)	Safety Green	Domestic Cold Water	White
Non Potable	Safety Green	Unsafe Water	Black
Domestic Hot Water (Potable)	Safety Green	Domestic Hot Water	White
Domestic Hot Water Return	Safety Green	Domestic Hot Water Return	White
Fire Protection Water	Safety Red	Fire Protection	White
Glycol Solution	Safety Purple	Glycol Solution	White
High Temperature Supply	Safety Yellow**	High Temperature Water Supply	Black
High Temperature Return	Safety Yellow**	High Temperature Water Return	Black
Secondary Heating Water Supply	Brown	Heating Water Supply	White
Secondary Heating Water Return	Brown	Heating Water Return	White
Deionized	Safety Green	Deionized Water	White
Distilled Water	Safety Green	Distilled Water	White
Reverse Osmosis	Safety Green	Rev. Osmosis Water	White
Softened	Safety Green	Softened Water	Black
Roof Drain	Safety Green	Roof Drain	White
System Make-Up	Safety Green	Make-Up Water	White
Treated Water	Safety Green	Treated Water	Black
WASTE			
Acid-Resistant	(unpainted)	Acid Waste	White
Building Waste	(unpainted) or Black	Waste	White

MEDIUM IN PIPE OR DUCT	BACKGROUND COLOR	IDENTIFYING LETTERING	LETTERING COLOR
Polluted Water	Black	Polluted	Safety Yellow
ALL EQUIPMENT OR PIPING LOCATED OUTSIDE BUILDINGS			
All Equipment or Piping Located Outside Buildings	Brown	---	---

(11) System Commissioning

- a. The A/E shall cooperate fully with the commissioning agent during all phases of the project from inception of design through final seasonal testing. Support shall consist of but not be limited to the following items:
 - i. Provide technical material and project documentation to the commissioning agent
 - ii. Respond to project issues in the commissioning issues log on a timely basis
 - iii. Participate in commissioning meetings and inspections
 - iv. Collaborate with the commissioning agent and contractor to resolve commissioning findings

(12) Refrigerants

- a. R410a only is allowed for new equipment. R22 is only allowed to maintain current equipment. Use of all other refrigerants is to be approved by facilities through the University Project Manager.
- b. All applicable health and safety requirements for specified refrigerants shall be included in the design. These requirements shall include, but not be limited to, ASHRAE safety items noted in Standards 34 and 35, and NIOSH Workplace Guidelines.

C. High Performance Building System

- (1) No additional University design requirements.

D. Operability and Maintainability

(1) Access for Maintenance

- a. For elevated equipment design an appropriate platform for convenience and safety. If an access platform is not practical, coordinate with Facilities Management through the University Project Manager for an approved design of a lifting point or other means of maintenance access.
- b. All ductwork and piping at walking level that must be crossed for equipment maintenance and service shall have a cross-over ladder.

E. Alterations in Existing Buildings and Historic Structures

(1) Heating Systems

- a. Where existing steam systems must be extended or revised, verify the existing demand and generation capacity before adding any steam equipment to the system. The A/E shall detail the locations for each connection point for the Contractor.

(2) Extensions / Modifications of Existing Systems

- a. Building heating and cooling systems which are to be extended or modified will require analysis of the existing mechanical systems to determine the capacity available for expansion.

(3) Review of Existing Systems

- a. Existing Systems to Original Working Capacities
 - i. Modifications or extensions to an existing system require a thorough analysis and understanding of the impact on the original system. The A/E shall insure that its design includes adjustments to the original building systems (including record (as-built) drawings with modified performance values shown) to return all adjacent systems to original working capacities. If the original condition cannot be determined, then the A/E shall include the services of balancing technicians in his fee to determine the actual status of the existing systems.
 - ii. Verify with facilities as to the current set-points of the system. Do not rely solely on record drawings for system set-points.
- (4) Existing System Commissioning
 - a. Any HVAC system that is modified shall be rebalanced and recommissioned, see DFCM Design Requirements 5.12 for additional requirements. If the unit modified serves more than the area under the current scope of work, the entire area served by that unit must be re-balanced and recommissioned. If this presents undue hardships on the project scope/budget, an exception may only be granted in writing by Facilities through the University Project Manager.

3.2 Plumbing

A. Domestic Water Supply System

- (1) Generally, the water pressure on campus exceeds 80 psig. Refer to [3.2 C](#) for the University's water distribution system requirements.
- (2) All pressure regulators shall be adjustable, diaphragm type, globe style valve.
- (3) All pressure reducing valves (PRVs) are to be located in an accessible space 5 feet above finished floor for servicing. Strainers should be Class 250 rated, with a cast bronze or iron body, threaded ends, solid retainer cap. Install ball valve on strainer to allow for draining.
- (4) Ball valves shall be Class 250 rated, with bronze construction, bubble tight PTFE seats, with hard chrome plated brass or stainless steel ball.
- (5) Check valves shall be bronze, Y-pattern, and Class 250 rated.
- (6) Valves shall be domestically manufactured.
- (7) Valves 2.5-in and larger shall be flanged.
- (8) Specify valve stem installation to be horizontal or higher than the valve.
- (9) Install two (2) full size reduced pressure backflow preventers piped in parallel at the building water entry of lab and research buildings. Install one (1) full size and one (1) half size reduced pressure backflow preventer in parallel at the building water entry of office and classroom buildings.
- (10) Water supply systems scheduled for removal or demolition shall have their supply (and return) piping removed and capped at an active main or branch line to prevent stagnation in an idle branch pipe. All abandoned piping shall be removed.

B. Hot Water Service

- (1) Provide two pumps on the domestic hot water for HTW domestic water converters. Two pumps allow for standby and alternating use. Maintain domestic water circulation through the HTW converter at low use times to prevent damage and extend the life of the converter. Provide lead/lag controls for pumps.
- (2) Domestic hot water systems using HTW heat exchangers are to be designed with multiple storage tanks to allow maintenance on one tank while the system remains in service. Refer to [3.8 D](#) for heat exchanger requirements.

- (3) Water conditioning systems shall be designed for all buildings which supply potable (or non-potable) hot water for classroom sinks, toilet room lavatories, laboratory sinks, etc. These shall be provided with water softening equipment for this hot water.
 - a. All water conditioning systems shall have built in totalizing water meters on the inlet line and on the conditioned water supply line.
 - b. The design of all water conditioning systems shall include a hose bib in close proximity to installed equipment for mixing and tank filling activities. Include a floor drain when chemicals will be used in the equipment.
 - c. Water softeners shall have duplex resin tanks, a single brine tank which shall not exceed 48" in height, and an automatic regeneration system activated by the amount of flow, not by time clock. Blow in salt delivery systems are required.
 - d. Water softening or conditioning equipment shall be based on GE Osmonics, Pacific Water Incorporated, Water Specialties, or Fluid Treatment Systems, or approved equal. All other manufacturers shall be reviewed and approved by Facilities Management prior to bid.
 - e. Additionally, water conditioning equipment shall be provided for secondary steam and water systems connected to HTW generators and converters. Include water conditioning of makeup and feed-water to HTW steam generators.
 - f. Many applications such as laboratories or research buildings on campus require conditioned water other than softened water. Requirements may include deionized water, reverse osmosis water, filtered water, or a combination of these to achieve the proper degree of purity or polishing. The level of water purity needed shall determine the type of pipe material required.
- C. Sanitary Waste and Vent Systems
 - (1) Drain, waste, and vent piping scheduled for removal or demolition shall be capped at the main. All abandoned piping shall be removed and not left in place.
 - (2) Indirect piping shall be Type L hard drawn copper pipe with wrought copper fittings and lead free solder.
 - (3) Acid Resistant Waste Systems shall be provided in all lab areas or other areas such as lecture rooms, etc. using chemicals. The designer is responsible for choosing suitable piping material based on the type of acids which will be used in the pipe. For lab remodels or additions, match existing pipe material.
 - a. Acid resistant waste systems shall be directly connected to drain. Indirect drain systems are not acceptable.
 - b. Neutralization tanks shall be used on systems less than eight (8) fixture units or 30 gallons per day.
 - c. Dilution tanks shall be used on system greater than eight (8) fixture units or 30 gallons per day.
 - d. Support horizontal acid waste piping with a continuous full length channel or angle iron.
- D. Rainwater Drainage System
 - (1) All roof drains shall drain to pervious area or be captured for reuse.
- E. Plumbing Fixtures
 - (1) Fixtures in one building shall be of one manufacturer.
 - (2) All lavatories shall be provided with open grid strainers and not pop-up or other type of closeable drains.
 - (3) Specify eye wash and emergency shower fixtures with manual open and closing ball valves. Flushometer or self-closing valves are not acceptable. Accessible isolation valves

- are to be provided near each station.
- (4) New laboratories requiring emergency showers shall be designed with floor drains located under the emergency shower.
 - (5) Emergency eye wash and shower fixtures shall be specified as Haws, Bradley or Guardian Equipment.
- F. Natural Gas Systems
- (1) The University requires the gas meter to be installed outside the building at an easily accessible and well vented area away from any building air-intake.
 - (2) No gas lines shall be run underground downstream of the building regulator/meter set.
 - (3) Natural gas supply systems scheduled for removal or demolition shall have the piping removed and capped at an active main or branch line. All abandoned piping shall be removed.
- G. Fuel Oil Systems
- (1) No additional University design requirements.
- H. Compressed Air Systems
- (1) Specify Type L hard drawn copper with wrought copper solder fittings and lead free solder; or, ASTM A53 Grade A or B, Schedule 40 galvanized steel with 150-lb galvanized malleable iron screwed fittings.
 - (2) Ball valves for use in compressed air piping shall follow the University's requirements for domestic water applications.
 - (3) Butterfly valves for use in compressed air piping shall be ductile iron body, 200# WOG valve with bronze disc and type 304 stainless steel stem. The seat shall be specified Buna N rubber. Note that valves 5-in and smaller are to be specified with 10-position locking levers; and valves 6-in and larger are to be specified with manual gear operators. Butterfly valves shall be rated for temperatures up to 180° F maximum and shall be capable of tight shut-off at rated pressure without the need for downstream blind flanges.
- I. Vacuum Piping Systems
- (1) Vacuum Piping Systems shall be designed to prevent extraneous liquids in the system from exiting out through the vacuum hose cocks into the labs. Horizontal branch lines shall grade down 1-in per 40-ft towards the mains and shall enter into the top of the mains.
 - (2) Hose cock shall connect into the top of the branch lines and back-to-back hose cocks are not allowed.
 - (3) Vertically dropped lines shall be used only where no other routing method is available, and all remaining piping shall be sloped back to the vacuum source. If terminal vacuum lines are to drop vertically to terminal outlets, such outlets shall be trapped with convenient access and accompanying written instructions describing when and how to clear the trap.
 - (4) A receiver tank shall be required upstream of any vacuum pump or set of vacuum pumps to prevent liquids or solids from entering the pump.
 - (5) Specify Type L hard drawn copper with wrought copper solder fittings and lead free solder; or, ASTM A53 Grade A or B, Schedule 40 galvanized steel with 150-lb galvanized malleable iron screwed fittings.
 - (6) Ball valves for use in vacuum piping shall follow the University requirements for domestic water applications.

- (7) Butterfly valves for use in vacuum piping shall follow the University requirements for heating and air conditioning water service, except that all sizes are to be specified for non-leakage performance up to and including 29.9 inches of mercury (Hg).

3.8 HVAC Systems

A. Air Distribution Systems

(1) VFD By-Pass Switch

- a. Variable frequency drive systems shall be supplied with a by-pass switch allowing full speed operation upon VFD failure, refer to [3.5 F \(3\)](#) for requirements.
 - i. Bypasses are not required on systems where redundant capacity is installed, each individually supplying the system design flow rate.

(2) Fan powered VAV boxes are not to be used.

B. Piping System

(1) Glycol Systems

- a. Glycol systems shall be contained within mechanical rooms. Piping throughout the building shall contain no glycol. Any remote systems requiring glycol, service water shall be routed to the location with a plate and frame heat exchanger in a mechanical space with glycol introduced at that point.

(2) Hydronic Flow Control Balancing Devices

- a. Flow control devices shall be provided at all major terminal devices such as coils, converters, etc. Flow control devices are to have marked memory stop and handles are to be removed after balancing. Additional isolation valves are to be provided to prevent the use of flow control devices as shut-off valves. Pumps with variable speed drives shall not have flow control devices installed on them.

(3) Triple duty valves are prohibited.

(4) Design Requirements

a. Design Parameters for System Calculations

- i. System Operating Pressure = 460 psig for both “upper” and “lower” zones.
- ii. System Operating Temperature, “Upper Zone” = 390° F.
- iii. System Operating Temperature, “Lower Zone” = 435° F.
- iv. Minimum Approach Temperature:

$$\text{APPROACH TEMPERATURE} = (\text{HTW RETURN TEMP } ^\circ\text{F}) - (\text{SECONDARY SUPPLY TEMP } ^\circ\text{F})$$

- b. HTW steam generators:
 - i. 10° F (for 45 psig to 100 psig steam operating pressures)
 - ii. 15° F (for 44 psig and lower steam operating pressures)
- c. HTW water-to-water converters and water heaters, 15° F
- (5) Maximum Pressure Drop
 - a. The maximum allowable pressure drop from the HTW building entry through each mechanical room including piping, equipment, and controls shall be 20 psig.
- (6) Equipment Ratings
 - a. All equipment, valves and piping shall be pressure and temperature rated based on requirements listed in this section.
 - b. HTW to heating water heat exchangers must be approved by Facilities Management prior to bidding and final selection.
- (7) Blowdown Heat Recovery on Humidifier Steam Generators
 - a. Steam generators used for humidification shall be designed with heat recovery on the blowdown line. The recovered heat shall temper the makeup water to the steam generator to avoid shocking the generator.
- (8) Piping System Design
 - a. Use Fanning or other equally acceptable formulae to calculate flow, velocity, and resistance of the water piping.
 - b. Shall conform to most current version of ASME B31.1
 - c. Consultant shall direct the Contractor to provide a weld-map including a copy of each welder's certification.
 - d. All valves are to be pneumatic, normally closed with spring return.
- (9) The maximum allowable pressure drop in branch lines from the main to building equipment and returning to the main shall be 2 psi per 100 equivalent feet of pipe, with a maximum water velocity of 7 feet/second.
- (10) Minimum pipe size shall be NPS 3/4 for HTW lines above ground and NPS 2-1/2 for underground branch lines.
- (11) The minimum bury depth to the insulation wrap shall be no less than 5 feet between the top of the insulation and the ground level for plain pipe. Thermacor Process L.P. Duo Therm "505" pre-insulated pipe requires a minimum bury depth of 24-in. If conditions require a shallower depth, the minimum bury can be 12-in for Thermacor "505" pipe if under a concrete slab on grade. The minimum insulation depth to the top of the pipe shall be 6-in (and varies to 10-in).
- (12) Buried pipe crossing over or under high temperature water lines.
 - a. Routing of new HTW piping may require revisions to existing underground utilities. New buried utility piping will require special considerations for crossing HTW piping.
 - b. To prevent damage to pipe and/or contents from the elevated temperatures expected at crossing high temperature water lines, the following requirements apply (with the exception of pre-insulated piping):

- i. Buried piping systems which shall cross over or under HTW lines shall be metal pipe (no plastic) for at least 5 feet either side of the cross point of the HTW pipe line.
 - ii. A buried water, sewer, or storm sewer pipe which crosses HTW piping shall be constructed of a 20-foot section(s) of ductile iron pipe, with the middle of the ductile pipe section centered over or under the crossing HTW pipe(s). The angle of crossing shall not be less than 60°. Any storm drain entry box, or piping joints within five feet lateral clearance of a crossing point over or under high temperature water piping shall have an epoxy concrete envelope around the storm drain joints.
 - iii. Buried pipe which crosses HTW piping shall have adequate vertical clearance; a minimum of two feet (2') is allowed without a copper guard. If the clearance between the crossing pipes shall be closer than two feet, design a 4' wide, 1/4" copper plate(s) midway between the crossing piping and the HTW piping. The copper plate(s) shall extend a minimum of 3 feet either side of the HTW piping.
 - iv. Buried electrical and telecommunications duct banks which cross HTW piping shall have adequate vertical clearance; a minimum of one foot (1') is allowed without a copper guard. If the clearance between the duct banks shall be closer than one foot, design a 4' wide, 1/4-in copper plate(s) between the duct banks and the HTW piping. See Detail HTW-18.
- (13) If new Thermacor Process L.P. Duo Therm "505" pipe system is to be installed, and a connection to an existing Gilsulate insulating fill system or a Z-Crete cast-in-place insulation system is required, design a transition which may include a vault, foundation, or doghouse. Direct connections between the differing pipe/insulation systems shall not be permitted.
- (14) Minimum size shall be NPS 3/4 for drains and NPS 1/2 for vents. Refer to drawing details provided herein. Gate valves shall be used on all HTW drains and vents.
- (15) Due to the high potential for high pressure water to flood adjacent areas, rooms shall be designed to contain water and quickly drain it away. All instrument air tubing in the HTW equipment rooms shall be copper.
- (16) HTW Vent Lines
 - a. Vent valves are to be installed at the highest point of the HTW system inside the building. Vent valves are also to be installed at the high point of each high temperature water converter (HTW side of each water and steam converter/generator) in both the supply and return piping.
- (17) Design to Minimize Shock
 - a. If the length of HTW piping between the control valve and the converter/generator exceeds 20 feet, include a bypass line near the converter/generator to allow HTW circulation which will serve to keep the idle HTW consistently hot and thereby prevent start-up shock.
 - b. When selecting heavy wall pipe (*i.e.* Schedule 80), the A/E shall account for the smaller inside pipe diameter in design calculations.
 - c. Submit detailed calculations to Facilities Management for review. The calculations used in the design of all HTW extensions shall be approved by Facilities Management prior to construction.

- i. Fathom model shall be updated, refer to utility section for modeling and delivery requirements.
 - d. Piping insulation thickness shall be shown in table form on the drawings or in the specifications.
- (18) Avoid Pad Support Under Heat Exchangers
 - a. Do not specify a housekeeping pad under HTW heat exchangers. Hydraulic lifts are used to remove heat exchanger heads and a minimum of 3 feet clearance is required at the floor behind the heads for proper access.
- (19) HTW Equipment Rooms
 - a. See [3.4 H](#) for special structural design requirements.
- (20) Emergency Shut-Off Control Valve at Building Supply
 - a. Include an emergency shut-off control valve at new buildings and new installations of a high temperature water system. Manual remote operation of the valve is to be located outside of the HTW equipment room near the door. The purpose of the emergency shut-off control valve is to protect the equipment room from destruction after a tube rupture or head gasket failure. The HTW emergency shut-off control valve shall have the following characteristics:
 - i. The control valve shall be installed inside the building on the HTW supply line and shall be full line size with a full port.
 - ii. Cast steel valve body conforming to ANSI Class 600 specifications. Flange surface shall match ANSI Class 600.
 - iii. The seat leakage shall be limited to the requirements of ANSI B16.104, Class IV. Control valve shall close against a 500 psi pressure difference and shall be suitable for 450° F.
 - iv. The control valve shall be specified normally closed, failing to the closed position on loss of control air. The valve shall be a rotary ball design with a side mount actuator that can be right or left of the pipe. Actuator shall be air operated with spring return. The maximum air to operate the valve shall be 60 psig. The maximum allowable air to actuator to be 125 psig.
 - v. Control valve shall have remote control for opening and closing through the campus automation system.
- (21) Blowdown Heat Recovery on Steam Generators
 - a. Steam generators shall be designed with heat recovery on the blowdown line. The recovered heat shall temper the makeup water to the steam generator to avoid shocking the generator.
- (22) System Review by Facilities Management
 - a. In all cases, piping design, equipment selections, and controls are to be reviewed with Facilities Management through the University Project Manager at each design phase.
- C. Building Automation
 - (1) Manufacturers: Subject to compliance with requirements, provide products by the following:
 - a. "Honeywell" controls as furnished and installed by Wasatch Controls
 - b. Trane US, Inc.
 - c. "Metasys" by Johnson Controls
- D. Chilled Water System
 - (1) Refer to [3.10 G](#) for additional chiller requirements.

1.4 ADDED Alternative Design

The Alternate Design is to provide a continuously exhausted laboratory ventilation system for new and existing research and educational laboratories under fire alarm and loss of primary building power conditions.

This Alternate Design will apply only to laboratories classified as Group B occupancies where the types and quantities of hazardous materials both stored and used per Control Area do not exceed quantities listed in Tables 307.71 (1) and 307.71.(2) of the IBC. Laboratory ventilation system supply and exhaust systems will be allowed to penetrate fire-rated exhaust shafts without fire and smoke dampers. Upon activation of the fire alarm and notification system or loss of primary electrical building power, the laboratory ventilation system supply and exhaust systems will operate at 50% of their maximum capacity.

Prescriptive Code requirements specify installation of fire and smoke dampers at the penetration of fire-rated shafts and floor assemblies with few exceptions. The intent of the Code for the installation of fire and smoke dampers is to prevent the spread of fire, smoke and fumes through these penetrations to other parts of the building. This requirement effectively cuts off the supply and exhaust air for laboratory ventilation systems under both alarm and loss of primary power conditions. The closure of fire and smoke dampers, when actuated, would prevent the exhausting of hazardous materials thus creating a more hazardous condition by allowing these materials to permeate the laboratory. The Comparison Chart identifies specific Code requirements and the equivalent design characteristics of the Alternate Design. As noted in the Comparison Chart, the Alternate Design will not deviate from the Code Requirements except for the provisions of the IBC Section 716.5.3.1.

In summary, the following outlines the required characteristics of the Alternate Design.

- The Alternate Design applies only to Group B occupancy laboratories.
- Fire and smoke dampers shall not be installed at the penetration of fire rated shafts and horizontal assemblies serving laboratory ventilation systems.
- The laboratory ventilation systems for new buildings shall include an adequate power source for the laboratory ventilation system, which will operate at 50% of their maximum capacity for a 90-minute time period following loss of primary building power.
- Alterations or additions to laboratory ventilation systems in existing buildings shall be connected to an existing alternate power source where available and where spare capacity exists. Otherwise, connection to the building's primary power is permitted.
- Alterations to an existing laboratory ventilation system that affect 50% or more of a floor or building shall be connected to an alternate power source.
- Any laboratory ventilation system associated with a Group H Occupancy shall comply with all prescriptive code requirements found in the International Code Council set of codes as adopted by the State of Utah.

3.1.1 ADDED Backflow Protection

Whether or not non-potable water is supplied to the hood, a spill-proof pressure vacuum breaker for high hazard application, with test ports shall be provided on the supply line outside each laboratory ventilation system. The backflow preventer shall be visible and easily accessible for testing. The backflow preventer shall be located 18" to 24" below the ceiling on the outside of the laboratory ventilation system or on an adjoining wall, and its critical line shall be a minimum of 6" above the highest outlet. The installing contractor shall test the backflow preventer and submit results to the University Project Manager.

3.2.7 ADDED Radioisotope Hoods

Radioisotope hoods shall be conventional hoods or bypass hoods. The University Radiological Health Department (RHD) shall be informed of each new radioisotope hood being planned for a project, or any such hoods to be modified or upgraded to radioisotope status. RHD will review the hood application and determine if any special treatment is required, such as charcoal or HEPA filters, nonstandard face velocities, etc.

3.3.1 CHANGED Face Velocity

The face velocity basis of design shall be 100 fpm at a sash height of 18" above the work surface.

The final product shall provide containment below a control level of AU (As Used) 0.1 ppm as determined by methods described in the ANSI/ASHRAE 110-1995 *Method of Testing Performance of Laboratory ventilation systems*.

3.3.3.1 ADDED Air Flow Monitoring

Air Flow Monitoring shall be mounted on the hood so as to be readily seen by the hood user. The indicator shall sense face velocity either directly or indirectly (belt driven sash sensors are not acceptable). The device shall provide digital display indicating face velocity with low/high flow audible and visual alarms (adjustable). Approved manufacturers include Phoenix Controls, TSI, or approved equal.

3.3.4 CHANGED Hood Location

All hoods should be located to minimize cross currents and turbulence from laboratory furniture arrangements and busy walkways.

3.4 ADDED Asbestos

Do not use materials containing asbestos in new hoods and cabinet installations. Existing laboratory ventilation systems containing asbestos materials can remain provided the asbestos is in good condition. All modifications to a hood that impact the asbestos materials shall be performed by a certified asbestos contractor.

3.5 ADDED Venting

Corrosive and flammable storage cabinets installed under laboratory ventilation systems shall be as follows:

- Corrosive Cabinets

Provide a vent pipe from the back of the cabinet to the work surface. The pipe must be located in the space behind the baffle. The vent pipe shall extend 0.5" above the work surface.

- Flammable Cabinets

Two vent pipes shall be connected to the back of the flammable cabinet through factory-installed bungs, one high and one low, and joined at a common vent pipe (minimum NPS 1-1/2 steel) which shall extend to the hood exhaust duct. The vent pipe shall be connected between the venturi damper and exhaust fan rather than between the laboratory ventilation system and the venturi damper.

- Install a flame arrester in the flammable cabinet's vent opening.

5.2.4 ADDED Hoar Frost

Make-up air systems shall include provisions to prevent hoar frost build-up at intake louvers and pre-filters.

5.2.4 ADDED Hydronic Coils

Cooling and heating coils installed in make-up air handlers shall have a glycol solution to prevent

the coil from freezing. See 3.5 Mechanical Part 1 for glycol systems requirements.

5.2.5 ADDED Electric Heating Coils

5.3.1.2.1 ADDED Duct Material

Duct material shall be 16 or 18-gauge Stainless Steel Series 316, welded with "MIG" or "TIG" method. Screwed slip joint connections sealed with silicone sealant are acceptable. Other duct material may be used, with prior approval.

5.3.1.3 ADDED Fans in Series

5.3.1.4 ADDED Velocities

Transport duct velocities shall be 1000-2000 FPM for gases and 3500-4500 FPM for particulates, depending on the particle size and specific gravity.

5.3.1.5 ADDED Dampers

Install a single blade volume control damper with locking quadrant in the hood duct between the hood and venturi damper for all laboratory ventilation system systems.

5.3.1.6 ADDED Elbows

The activation of a fire damper caused by a fire in a laboratory chemical hood will shut off airflow from that hood making it impossible to remove the combustion products from the hood and forcing the hood to become positively pressurized. This condition makes it likely the fire will escape the fire resistant hood into the laboratory.

With the exhaust flow from one or more hoods shut off, the laboratory may become positively pressurized with respect to the corridor, encouraging the spread of the combustion products, and perhaps the fire, from the laboratory to adjoining spaces.

5.3.2.12 CHANGED Constant Suction, Redundancy, Emergency Power

- Manifold Exhaust, New Construction

Manifold exhaust and makeup air systems shall be connected to an emergency power supply to ensure hood performance during power outages.

- Manifold Exhaust, Remodel or Renovation

Emergency power is not required.

- Individual Exhaust Systems (single-hood/single-fan)

Emergency power is not required.

5.3.3.1 ADDED Exhaust Fan Components

- Motors
- Coatings
- Fan Casing Drains
- Duct Pressure

5.3.3.2 ADDED Labeling and Identification

- Laboratory ventilation systems

All laboratory ventilation systems shall be clearly identified and labeled to indicate which fan or

ventilation system they are connected to.

- Exhaust Fans

All exhaust fans shall be clearly identified and labeled to show which hood(s) and/or ventilation systems they are serving. Exhaust fan labels shall indicate current and future design airflows and shall be updated whenever changes are made to the systems they are serving.

- Corrosive and Flammable Cabinets

All corrosive cabinets shall be labeled "Corrosive" and all flammable cabinets shall be labeled "Flammable".

5.3.5.1 ADDED Termination Devices

5.3.5.2 ADDED Corrosive Condensate

8.10.3.1 CLARIFICATION Automatic Fire Dampers

In 2001 at the University of California a fire resulted in an injury and caused approximately \$3.5 million in damage. Based on the investigation, it was concluded that not having the fire dampers on the exhaust duct of the ventilation system at the shaft wall appears to have been beneficial in this fire scenario. The investigation observed that the exhaust system was effective at removing significant quantities of combustion products from the building during the fire, thereby reducing the amount of combustion products spreading to other areas of the building. The shutting down of the supply air by fire dampers did not significantly hinder the exhaust system since fresh air was provided through a broken window. However, if the window had not failed, the team concluded that the exhaust system probably would not have performed as well.

If protection of the openings is desired, one method is to use a subject assembly. Where a branch duct connects to an enclosed exhaust riser located inside a shaft, which has a required fire resistance rating of 1 hour or more and in which the airflow moves upward, protection of the opening into the fire resistance-rated enclosure should be made with a steel subduct turned upward a minimum of .06m (22 in.) in length and a minimum thickness of 22 gauge [0.76 mm (.030)]. The steel subduct should be carried up inside the riser from each inlet duct penetration. This riser should be appropriately sized to accommodate the flow restriction created by the subduct.

-

COMPARISON TABLE	
CODE	ALTERNATE DESIGN
IBC:	
<p><u>IBC Tables 307.7(1) & 307.7(2)</u> Hazardous materials in quantities less than Tables 307.7(1 & 2) per Control Area to be classified as Group B occupancy. All others to be a Group H occupancy.</p>	No change to Code requirements.
<p><u>IBC Section 707.3.1</u> Fire resistive rated shaft enclosures at openings between stories for more than 2 stories.</p>	No change to Code requirements.
<p><u>IBC Section 714.3.1</u> Unprotected openings for penetrations less than 6" in diameter are permitted at shafts.</p>	No change to Code requirements.
<p><u>IBC Section 717</u> Penetrations by ducts and air transfer openings of fire resistive rated shaft enclosures are to be protected with approved fire and smoke dampers.</p>	Fire and smoke dampers are not allowed as they would interrupt supply and exhaust air for laboratory ventilation systems. Provides continuous supply air and exhaust for products of combustion and hazardous materials regardless of quantities.
IMC:	
<p><u>IMC Section 501.4</u> Exhaust system must maintain negative pressure and make-up air.</p>	No change to Code requirements.
<p><u>IMC Section 502.1</u> Exhaust system required for laboratories using hazardous materials.</p>	No change to Code requirements.
<p><u>IMC Section 502.8.2</u> Hazardous materials in any quantity to be in a negatively exhausted environment.</p>	No change to Code requirements.
<p><u>IMC Section 502.9.5</u> Flammable and combustible liquids in any quantity shall be provided with an exhaust system.</p>	No change to Code requirements.

COMPARISON TABLE	
CODE	ALTERNATE DESIGN
<p><u>IMC Section 510.2</u> A hazardous exhaust system shall be required wherever operations involving the handling or processing of hazardous materials, in the absence of such exhaust systems and under normal operating conditions, have the potential to create:</p> <ol style="list-style-type: none"> 1. A flammable vapor, gas, fume, mist or dust is present in concentrations exceeding 25% of the lower flammability limit of the substance for the expected room temperature; 2. A vapor, gas, fume, mist or dust with a health-hazard rating of 4 is present in any concentration; 3. A vapor, gas, fume, mist, or dust with a health-hazard rating of 1,2 or 3 is present in concentrations exceeding 1% of the median lethal concentration of the substance for acute inhalation toxicity. 	<p>No change to Code requirements. The design professionals will need to demonstrate that for the given project, chemical inventory quantities and list and the anticipated processes, that this provision is not a concern. Otherwise, a hazardous exhaust system will be required.</p>

3.9 Automatic Sprinkler Systems

A. Fire Extinguishing Systems

- (1) The University does not permit automatic fire sprinkler systems to be fabricated in combination with systems for heating or cooling, such as water source heat pumps connected to fire sprinkler piping.
- (2) Each valve in the fire protection system shall be provided with an approved supervisory switch or "tamper" switch (including post indicator valves and antifreeze loop control valves) wired into the fire alarm system of the building.
- (3) A flow switch shall be required at the main riser and at each isolated zone. New systems shall be separated into a different zone at each floor with a flow control assembly that shall include a flow switch, control valve and main drain tie-in.
- (4) Non-glycol fire protection sprinkler systems require drain valves at all low points and a system test/drain valve at the building riser.
- (5) The design is to include a floor sink at all drains discharging from sprinkler systems, including the inspector's test drains, low point drains and the system auxiliary drain at the building riser. Connect the floor sinks to the nearest sanitary sewer and provide an air gap at the floor sinks.
- (6) Antifreeze loops shall be separated from the fire extinguishing system with an isolation valve and a check valve.
- (7) Sprinkler heads in equipment rooms, storage rooms, etc. shall be furnished with guards.

B. Piping Systems

- (1) Schedule 40 black steel pipe shall be specified for piping sized 2-in and smaller.

- (2) Schedule 10 black steel pipe shall be specified for piping sized 2.5-in and larger.
- (3) Dry pipe systems require Schedule 40 black steel pipe.
- (4) The use of CPVC pipe is acceptable for use in Residential Occupancies and Light Hazard Occupancies. CPVC pipe shall be used according to its listing as prescribed by the manufacturer's specifications.
- (5) For 1.25-in and larger fittings, specify 150-lb malleable iron with mechanical grooved pipe couplings. Approved manufacturers are Victaulic, Gruvlok, and Grinnell.

3.10 Components

A. Air Handling Units

- (1) Indoor Air Handling Units: no additional University requirements
- (2) Roof-Top Units
 - a. Refer to [3.3 B \(10\)](#) for roof mounted equipment requirements.

B. Filtration

- (1) Refer to [3.8 N](#) for additional laboratory ventilation requirements.

C. Cooling and Heating Coils

D. Pumps

(1) HVAC Pumps

- a. Pumps specified for University projects are to include the following:
 - i. Base mounted pumps shall be specified to have bases grouted.
 - ii. Variable frequency drives with a by-pass switch allowing full speed operation upon VFD failure, refer to [3.5 F \(3\)](#) for additional requirements.
 - (a) Intent is to allow flow control over the full 20 to 60 Hz range, with 60 Hz being the design point for operating pressure at the flow design point.
 - (b) Bypasses are not required on systems where redundant capacity is installed, each individually supplying the system design flow rate.
 - (c) Pumps operating with VFDs shall be tested for maximum design flow rate and pressure developed once installed. If the design flow rate and pressure developed point occurs at less than 54 Hz, require the VFD to be reprogrammed to limit the amp draw

E. Boilers

F. Chillers

- (1) Replacing Chillers

3.11 Communications and Security Wiring Systems

A. Introduction

- (1) Designer Qualifications.

- a. The University expects a high quality, standards-based communications infrastructure on campus. The design of communications infrastructure for new or remodeled facilities shall be engineered by a qualified Registered Communications Distribution Designer (RCDD) actively affiliated with the Building Industry Consulting Services International (BICSI) organization. Further, engineering designs shall meet all applicable Federal, State, and local codes and standards, and shall be designed in accordance with this Design Manual and University of Utah Supplement.

- (2) Communications Entrance.

- a. The design for new buildings will include a communications service entrance and provisions for running communications conductors to various parts of the building. The scope of these provisions will be determined in consultation with Facilities Management through the University Project Manager. The communications service entrance will interconnect the building with the University underground communications duct system. The communications service entrance will include a minimum of six 4-in ducts into the building. The service entrance ducts shall be run without bends. Where this is not possible specific approval of Facilities Management electrical engineer(s) through the University Project Manager will be required.
 - (3) CAD Layering.
 - a. Telecommunications wiring, conduit, and raceways are to be layered separately from electrical layers.
 - (4) Installation by UIT.
 - a. In an effort to maintain a consistent structured wiring system throughout campus, University Information Technology (UIT) department is the only entity on campus authorized to install new communication cabling, both inside and between buildings. Therefore, the designer is to notify contractors that the University of Utah installs their own telecommunications wiring in new and remodeled spaces. Project specifications are to require the Contractor to coordinate the work with the University, thereby properly sequencing the installation of the wiring with the rest of the construction work. Wiring shall be completed prior to the installation of drop ceiling grid.
 - (5) Total Raceways.
 - a. It shall not be acceptable to run low voltage wiring as a free air system. All low voltage wiring systems shall be run in conduit in walls up to a raceway system. The raceway system can be specified as J-hooks, cable tray, conduit, or any other approved cable management system.
 - (6) Cable Tray.
 - a. Where appropriate cable tray shall be provided to facilitate the installation of communication cable in University buildings. Where provided, cable tray shall be installed in such a manner that free and unobstructed access is provided at all times after completion of construction.
- B. Communications Duct Banks
 - (1) General
 - a. Duct banks will be provided to house underground communication cables. See Detail Drawing COM-3. Duct banks will be concrete encased round bore plastic duct. Typically, the duct size should be 4 inches. Spare ducts will be provided in duct bank installations in consideration of the future needs of the campus communications system. Duct banks will have a minimum slope of 4 inches per 100 ft. Seal around all cables entering manhole with Virginia KMP Presstite Permagum. Provide plastic plugs in both ends of all unused ducts and seal with silicon sealant. Concrete encasement will be a minimum of three inches between ducts and between ducts and earth. The top of the concrete encasement will be a minimum of 3 ft. below finished grade. Care shall be taken during installation to insure no debris gets into the line. After completion a mandrel not less than 12 inches long and approximately 1 ½ inch diameter less than the duct diameter will be pulled through each duct to ensure that no debris has collected in the duct. Mandrel pulls shall be witnessed by the A/E and University Project Manager. The A/E should inspect duct bank construction before

concrete is poured. Provide polypropylene pull rope in each unused duct.

(2) Rigid Galvanized Steel

- a. Where duct banks enter manholes, buildings or vaults, a 10-ft. length of rigid galvanized steel conduit will be used for each duct. All elbows and offsets in duct runs will be made of rigid galvanized steel.

(3) Maximum Bend Radius

- a. All communications ducts shall be installed in such a manner as to be free of bends, twists, turns etc. Absolutely no 90, 45, 30-degree bends shall be allowed. A maximum bend radius of 5 degrees shall be allowed. Any other bend necessary shall require approval of Facilities Management Electrical Engineer(s) and the Campus Utility Services Electronics Shop (upon request to the University Project Manager). Any bends required greater than 5 degrees shall be rigid steel. The A/E shall provide elevation drawings that show elevation differences.

C. Telecommunications Service Entrance and Termination

(1) General Information:

- a. "Telecommunications service entrance" on campus is defined as the means by which connections for Local Exchange Carrier's, Campus Distribution, Interexchange Common Carrier, etc. will enter and terminate in campus buildings. Entrance conduit begins at the communications manhole nearest the structure and ends when terminated in the Equipment Room for that structure, see [3.11 D](#) for Equipment Rooms.

(2) Types of Entrances

- a. The acceptable means of service entrance on campus is an underground conduit system. All entrance conduit shall be 4-in PVC conduit, encased in concrete, and buried at a minimum of 24-inches below grade. The actual number of conduits designed for any campus structure will be determined by the University Project Manager and UIT Project Coordinator during the design phase of the project.
- b. On each new building, and where approved for each remodel, include a 2-in roof mounted galvanized rigid conduit with weather-head in the system design. The new conduit is to extend 2-ft above the finished roof. The base is to be sufficiently secured to support future electronic equipment which may be attached to the conduit. The designer shall coordinate with the A/E for a location:
 - i. which is reasonably close to (preferably directly over) a telecommunications room;
 - ii. which is near a roof access for maintenance and service; and,
 - iii. which would have walkway approach protection to limit the possibility of roof damage. If possible, this roof conduit should be located directly over the top floor telecommunications room. Extend conduit into the building either to the telecommunications room or to the nearest communications cable tray. Review the design with the University Project Manager and UIT project coordinator for approval at the design development submittal review or prior to completion of the bidding documents.

(3) Bends

- a. Bends in service entrance conduit are generally considered unacceptable. However, should bends be unavoidable, they shall be reviewed for approval by Facilities Management and UIT prior to installation; and, they will be long, sweeping bends with a radius not less than ten times the internal diameter of the conduit. There shall

be no more than the equivalent of two quarter bends (180° total) between pull points. All bends and sweeps are to be in rigid conduit.

(4) Preventing Shearing:

- a. In order to prevent shearing of conduits, each entrance conduit is required to have 10-feet of rigid steel conduit leaving and entering any structure including buildings, manholes, etc. Ends of metallic conduit shall be reamed and bushed.

(5) Manholes

- a. Communication manholes will be provided for the underground communications distribution system.
- b. Manholes used for communications will not be used for the distribution or termination of any electrical cables.
- c. Communication Manhole Fabrication Requirements
 - i. Covers will be clearly marked "COMMUNICATIONS".
 - ii. Communications manholes will have a minimum of 96 square feet of floor area (unless pre-approved by UIT) with a minimum 8-ft ceiling height; and, are to be reinforced concrete, either poured in place or pre-cast; and, must be suitable for H20 highway loading.
 - iii. Manholes must be equipped with bonding inserts and struts for racking. Include cast-in provisions for cable supports (equal to Super Strut Series No. C300).
 - iv. Include pulling eyes cast into each wall of the manhole. Pulling eyes shall be at least 2.2-cm in diameter.
 - v. Manholes must include a sump of at least one (1) cubic yard of crushed rock with a 3-ft diameter.
- d. Required manhole accessories shall include, but not be limited to:
 - i. Manhole cover and seat shall be in accordance with Detail Drawing COM-4.
 - ii. Require a minimum of two ground rods for each manhole, each shall be 3/4-in x 10-ft, copper clad steel, and each ground shall extend below the manhole at opposite corners of the manhole floor.
 - iii. Require complete water proofing of the manhole, entrance structure, and all openings.
 - iv. Require bell end entrances for all conduits. Specify threaded metallic type Emerson O.Z. Gedney Bell End Entrances (or equal). Require the Contractor to seal all conduit entrances.
 - v. Require a demountable stainless steel ladder affixed at both top and bottom, but removable from below by the worker if desired.
 - vi. The ladder system, including all hardware, is to be submitted for review and approval before purchase and installation.
 - vii. The ladder top shall be hooked to the side of the manhole.
 - viii. Each bottom rail shall be drilled to receive a security pin which locks the ladder to angle flanges anchored to the concrete manhole floor. Specify both the pin and its associated pin lock to be attached to the ladder rail by stainless steel chain to prevent misplacing the pin locking devices (the required security chain is not shown in the picture below). This assembly will provide a safe entry descent, and enable workers to unpin the bottom rails and unhook the ladder top when additional workspace is desired while working in the manhole.

- ix. All hardware shall be specified stainless steel.
- x. The following pictures indicate the approved attachments, except for the required *pin-to-pin lock-to-ladder rail* stainless steel chains (one for each ladder rail) described above.



- e. Spacing of manholes will be carefully considered to allow reasonable pulling tensions for cable pulls between manholes. Spacing between manholes shall not exceed 400-feet.
 - f. The University of Utah requires all communications manholes to be fitted with a secure access system. Coordinate with the University Project Manager and UIT for current approved details regarding manhole security and access systems. The only approved secure access system is manufactured by the University Metal Shop, with a lock provided by the University Key Shop. When manholes are included in the design, coordinate with the University Project Manager to either:
 - i. Cover the cost by internal work order, or
 - ii. Notify Facilities Management Business Services that an allowance of \$1,000 is required on the Bid Response Form when bidding documents are being prepared. The work order amount or bid allowance shall be \$1,000 for each manhole.
- (6) Terminating Conduit Inside a Building
- a. Service entrance conduits should enter the communications room without bends. If the conduits enter the building below the finished floor, this is best accomplished by creating a trench for the conduits to enter. The trench must be a minimum of three (3) feet wide to allow the bending of cable inside the trench. The trench must be fitted with a steel grate to cover the entire span of the trench. Knockouts in the grate, for cable entrance and exit, must be provided. The grate must be capable of withstanding weight in excess of 1,000 pounds. If conduits enter from the ceiling, they should terminate 4-in below the finished ceiling. It is imperative that slope and grade be considered in the design and installation of entrance conduits, ensuring that conduits inside the building are not lower than the conduits leaving the manhole, thus creating drainage problems.
- (7) Redundant Entrance Provision

- a. All new buildings shall be equipped with dual entrance facilities, originating from separate manhole structures. All standards that apply to the primary entrance facility apply to the redundant facility. Any deviation from this standard shall be approved by both the University Project Manager and UIT Project Coordinator.
 - (8) Fill
 - a. All conduit must be concrete encased.
- D. Equipment Rooms (ER)
 - (1) Equipment Rooms (or “ER”) provide secure space and maintain suitable operating environments for large communications and/or computer equipment. Equipment Rooms are generally considered to serve a building, where Telecommunications Rooms generally serve only one floor of a building. Any or all functions of a Telecommunications Room may be provided by an Equipment Room.
 - (2) The Equipment Room is typically the point of demarcation (“dmarc”) for the following services:
 - a. Local Exchange Carrier (Qwest)
 - b. Fiber Optic Network
 - c. Building Maintenance Systems
 - d. Security Systems
 - (3) Considerations for Design
 - a. When designing Equipment Rooms, consider incorporating building information systems other than traditional voice and data communications systems (*e.g.* CATV distribution systems, alarm / security systems, and audio/paging systems). In most instances, the Equipment Room may also serve as the entrance facility for the building communication.
 - b. The design of a new Equipment Room should begin with an assessment that considers each of the factors listed below. The information gathered from this assessment shall be considered by the designer at all stages of the project design, along with guidelines and requirements of applicable local, state, federal standards, this Design Manual and the University of Utah Supplement.
 - i. Customer Requirements
 - ii. Telecommunications Pathway Locations
 - iii. Service Provider (Local Exchange Carrier [LEC]) Requirements
 - iv. Environment/Facility Conditions and Resources
 - (4) Locating the Equipment Room
 - a. The location of the main Equipment Room can have significant impact on all other aspects of communications systems distribution design. Location selection is to include consideration of spaces immediately adjacent to the Equipment Room (beside, below, and above). In general, the main Equipment Room should be located near the building center to minimize cable distance.
 - b. Design of Equipment Rooms shall take in to consideration:
 - i. Services to be terminated
 - ii. Access and proximity to distribution cable pathways
 - iii. Building facilities and access to the Equipment Room
 - iv. Local Exchange Carrier (LEC) requirements

- v. Proximity to electrical service and EMI sources
 - vi. Space required for equipment
 - vii. Provisions for future expansion
 - c. Do not locate Equipment Rooms in places that are subject to the following conditions:
 - i. Water infiltration
 - ii. Steam infiltration
 - iii. Humidity from nearby water or steam
 - iv. Heat (*e.g.*, direct sunlight)
 - v. Any other corrosive atmospheric or environmental conditions
 - d. Shared use of Equipment Room space with other building facilities shall be avoided. Locations which are unsatisfactory for Equipment Rooms include space in or adjacent to:
 - i. Electrical Closets
 - ii. Boiler Rooms
 - iii. Washrooms
 - iv. Janitor Closets
 - v. Storage Rooms
 - vi. Any space that contains sources of excessive EMI; hydraulic equipment or other heavy machinery that may cause excessive vibration, steam pipes, drains, or clean-outs
 - e. Avoid locations that are below the water level unless preventive measures against water infiltration are employed. The room shall be free of plumbing and electrical utilities that are not directly required to support the Equipment Room function. A floor drain is required if there is any risk of water entering the facility.
- (5) Working Clearances
- a. NEC Section 110-16 requires three (3) feet of clear working space around equipment with exposed live parts. This applies to communication Equipment Rooms.
- (6) Conduit Accessibility
- a. It is essential that clear, unobstructed access to cable trays and conduits be provided within the Equipment Room. Entrance conduit and distribution conduit/cable trays should enter and exit on the same wall. If this is not possible, a cable tray inside the room should be provided for distribution from wall to wall.
- (7) Electrical Systems
- a. Power for telecommunications equipment in Equipment Rooms should be supplied by feeders dedicated only to supplying that equipment (NEC Article 215). Quadplex power receptacles with separate 20-amp feeders and isolated grounds, should be mounted on every wall in the Equipment Room, spacing should be on 6-ft centers, and located 84-in above the finished floor. Other power requirements (*e.g.* fluorescent lighting, motors, air conditioning equipment, etc.) should be supplied by a separate feeder, conduit, and branch panel.
- (8) Dimensions
- a. Determination of “adequate size” for the Equipment Room depends upon what services are to be terminated there. Input from UIT personnel, LAN support groups,

Electronics Shop, HVAC and UCard personnel should be considered. Minimum size for an Equipment Room is 10-ft by 15-ft. The actual size of the Equipment Room will be determined during the design phase of the project when more information, pertinent to the size and application of the building, is available.

(9) Space Allocation & Layout:

- a. The layout of major communications equipment in the main Equipment Room shall facilitate the effective routing of power and communications cabling. The main Equipment Room shall provide adequate space for:
 - i. All planned equipment
 - ii. Access to equipment for maintenance and administration
 - iii. Future growth
- b. In addition to space for communications and security system requirements, an Equipment Room may also include space requirements for environmental control equipment, power distribution/conditioners, and UPS systems.

(10) Determining Size of Equipment Rooms (Based on Area Served)

- a. When specific equipment that may be used in an Equipment Room is not yet known, the following criteria may be used to determine the minimum size of the Equipment Room.
 - i. Divide the amount of useable floor space (building area used by occupants during normal daily activity, including hallways, copier rooms, etc.) by 100 ft.² (or smaller if average work area size is less) to determine the number of individual work areas; or, count the number of individual work areas (offices, conference rooms, cubicles, etc.).
 - ii. Multiply the number of work areas to be served by 0.75 ft.² to determine the minimum Equipment Room size.
- b. If there are fewer than 200 work areas, the Equipment Room shall be no less than 150 ft.². In special use buildings (hospitals, hotels, etc.) Equipment Room sizes may vary. Refer to ANSI/EIA/TIA-569-B.

(11) Fire Protection / Fire Rating / Fire Suppression

- a. All ER spaces shall be designed with pre-action fire suppression systems (the space remains water free until both heat and smoke detectors are activated). Fire alarms should be installed in accordance with [3.5 H \(5\)](#). Portable fire extinguishers should be located in the room as close to the entrance as possible. A minimum of a 2-hour fire rating should be provided with a fire sprinkling system exterior to the room.

(12) Environmental Considerations

- a. Environmental considerations should be determined prior to design; however, assume that air conditioning will be a year-round requirement and should be capable of maintaining a maximum temperature of 75 degrees F and a relative humidity of 30% to 50%.

(13) Floor Requirements

- a. Equipment Room spaces are generally considered to be computer rooms. Design these rooms with raised floors, 18-inch clearance (minimum), to ensure maximum flexibility of power and communication cabling.

(14) Loading Requirements

- a. The floor rating under distributed loading must be greater than 12 Kpa (250 lb/ft.²).

- b. The floor loading under concentrated loading must be greater than 4.4 M (1,000 lbs) in areas that will support communications equipment, racks, and cabinets.
- (15) Ceiling Requirements
- a. The recommended height of the finished ceiling to the finished floor in an Equipment Room is sufficient height to allow 8 ft. 6 in. clear space below light fixtures. Any ceiling protrusions (ventilation, sprinklers, etc.) must be located with a minimum clearance height of 8 ft. 6 in. The ceiling finish must minimize the introduction of dust, and be light colored to enhance room lighting.
- (16) Lighting Requirements
- a. Equipment Rooms shall be designed with adequate and uniform lighting that provides a minimum equivalence of 540-lux (50 foot-candles) when measured 3 ft. above the finished floor. Locate lighting fixtures a minimum of 8 ft. 6 in. above the finished floor. Locate light switches near the entrance(s) to the Equipment Room. Power for lighting should not come from the same circuits as power for the communications equipment. Provide emergency lighting as required by applicable building codes.
- (17) Security Design Considerations
- a. Provide adequate clear wall space to accommodate the required number of CCure iStar security control panels as determined by UCard. Provide an adequate quantity of power outlets to serve the iStar panels.
- (18) Cable Management
- a. Cable management, either overhead or under the floor, must be given careful consideration during design. As a minimum, all communication spaces shall be designed with cable trays installed at a height of 108-in above the finished floor, with minimum dimensions of (4" d x 12" w) and which wraps the entire room. Considerations for additional cable trays and/or raised floor will require consultation with the University Project Manager, the UIT project coordinator, and the tenants of the proposed building or space.
- (19) HVAC Requirements
- a. Telecommunications equipment requires full time operation of heating, ventilating, and air conditioning in the room to meet the criteria shown below. If the building's HVAC system cannot provide continuous service to satisfy the ER room's environmental requirements, consult with the University Project Manager and UIT project coordinator to consider an independent HVAC system. If approved, each ER space would be designed with an independent cooling system capable of operation when other chiller and ventilation systems may be interrupted (*e.g.* fire alarm tests, maintenance, season off-times for cooling or heating, etc.). The system should be designed with a high performance cooling system utilizing positive pressure techniques.

TEMPERATURE RANGE	64 degrees to 75 degrees F
HUMIDITY RANGE	30 percent to 55 percent relative
HEAT DISSIPATION	750 to 5,000 BTUs per hour per cabinet (number of cabinets to be determined through consultation with Facilities Management through the University Project Manager).

- (20) Electromagnetic Interference (EMI)
 - a. Because EMI causes severe problems with electronic equipment, telecommunications rooms shall not be shared with electrical feeders, branch circuits of noisy equipment or transformers.
- (21) Un-Interruptible Power Systems (UPS)
 - a. A building UPS system shall be installed and connected to all communication spaces; and, should be equipped with access to building emergency generator power to protect critical voice and data systems. The sizing of the UPS will depend on the size and use of the building which is to be determined during the design phases with the assistance of UIT and the building occupants' IT staff.
- (22) Telecommunications Grounding and Bonding
 - a. A proper grounding and bonding infrastructure is essential for the reliable operations of today's sensitive telecommunications equipment and systems.
 - b. The building telecommunications grounding and bonding should follow ANSI-J-STD-607-A. This standard is intended to augment (not replace) the requirements specified in the NEC.
 - c. The grounding and bonding infrastructure originates at the electrical power service entrance and extends throughout the building. Pre-drilled copper grounding bus bars are to be installed in all TR's and ER's.
 - d. Whenever two or more telecommunications bonding backbones (TBB) are used within a multistory building, they are to be bonded together with a grounding equalizer (GE) at the top floor and every third floor in between.
 - e. The size of wire used in the telecommunications bonding backbone is distance driven. See Drawing Detail COM-2.

TELECOMMUNICATIONS BONDING BACKBONE LENGTH (FT)	TELECOMMUNICATIONS BONDING BACKBONE (AWG)
1 – 13 feet	6 AWG
14 – 20 feet	4 AWG
21 – 26 feet	3 AWG
27 – 33 feet	2 AWG
34 – 41 feet	1 AWG
42 – 52 feet	1/0 AWG
53 – 66 feet	2/0 AWG

- E. Telecommunication Rooms ("TR")
 - (1) Telecommunications Rooms differ from Equipment Rooms and entrance facilities in that they are generally considered to be "floor-serving" (as opposed to "building-serving") spaces that provide a connection point between backbone and horizontal distribution pathways. Requirements for the design of ERs found in this document, specifically

power/UPS, HVAC, fire alarm / suppression, security, cable management, and electrical systems also apply to TR design.

- (2) Telecommunication Rooms are “floor-serving” spaces for:
 - a. Voice equipment (e.g. KSU's, etc.)
 - b. Data equipment (routers, concentrators, etc.)
 - c. Cable terminations (both horizontal and backbone)
 - d. Fiber optic terminations (both horizontal and backbone)
 - e. Cross-connect wiring
- (3) Size
 - a. TRs vary in size depending on their function and the size of the floor area they serve. Typically size requirements are based on distributing telecommunications service to one individual work area per 100 feet² of occupied work space. While the actual size of Telecommunications Rooms will depend on the application of the building and therefore will require input from various entities during the design phase of the project, minimum Telecommunications Room sizes are shown in the table below:

IF THE SERVING AREA IS....	THEN THE TR MUST BE AT LEAST....
Below 740 meters ² (8,000 feet ²)	3.0 meters x 3.0 meters (10 feet x 10 feet)
Larger than 740 meters ² (8,000 feet ²)	3.0 meters x 3.6 meters (10 feet x 12 feet)

- (4) Working Clearances
 - a. NEC Section 110-16 requires three (3) feet of clear working space around equipment with exposed live parts. This applies to Telecommunication Rooms.
- (5) Conduit Accessibility
 - a. It is essential that clear, unobstructed access to cable tray and conduits be provided within the Telecommunication Room. When possible entrance conduit and distribution conduit/cable tray should enter and exit on the same wall, if this is not possible cable tray inside the room should be provided for distribution from wall to wall.
- (6) Electrical Systems
 - a. Power for telecommunications equipment in Telecommunications Room should be supplied by feeders dedicated only to supplying that equipment (NEC Article 215). Quadplex power receptacles with separate 20 amp feeders and isolated grounds, should be mounted on every wall in the Telecommunications Room, spacing should be on six (6) foot centers, located 84-in above the finished floor. Other power requirements (e.g. fluorescent lighting, motors, air conditioning equipment) should be supplied by a separate feeder, conduit, and branch panel. Refer to [3.11 D \(22\)](#) for grounding requirements.
- (7) Lighting
 - a. Telecommunication Rooms should have adequate and uniform lighting. Design room lighting to maintain an intensity of 50 foot-candles (LM/ft²) at 3 feet above floor level. Coordinate light fixture positions with the equipment layout, especially overhead cable trays, to ensure the light is not obstructed.
- (8) HVAC Requirements

- a. Telecommunications equipment requires full time operation of heating, ventilating, and air conditioning systems. If the building's HVAC system cannot ensure continuous operation (including weekends, holidays, off-season, maintenance, etc.), coordinate with the University's Project Manager and UIT to consider stand-alone systems with independent controls. Typical room requirements are as follows:

TEMPERATURE RANGE	64 degrees to 75 degrees F
HUMIDITY RANGE	30 percent to 55 percent relative
HEAT DISSIPATION	750 to 5,000 BTUs per hour per cabinet (number of cabinets to be determined through consultation with Facilities Management through the University Project Manager).

(9) Structural Guidelines

- a. Telecommunications Room walls should extend from the finished floor to the structural ceiling (*e.g.* the slab).
- b. If ceilings shall be installed, they shall be a minimum of 2.6 meters high to provide space over the equipment frames for cables and suspended racks.

(10) Fire Alarm

- a. A fire alarm should be installed in all Telecommunications Rooms. A portable fire extinguisher should be made available inside all Telecommunications Rooms. Refer to [3.5 H \(5\)](#) for fire alarm requirements.

(11) Locating Telecommunication Room

- a. It is imperative that TRs be located so as to minimize cable lengths for both horizontal and vertical cable runs.
- b. Vertical Distribution
 - i. When designing TRs for vertical distribution it is preferable to "stack" TRs so that the Telecommunication Room on level one is located directly below the Telecommunications Room on level two, etc. TRs should be connected to one another via four (4), 4-in conduits. Conduits should penetrate the floor in the TR on the far left corner of the TR, and extend no less than 2-in above the finished floor.
- c. Horizontal Distribution
 - i. Telecommunication Rooms shall be located so as to maintain a distance no greater than 90-meters (cable length) from the furthest termination point (communication outlet) being served by that TR. Ensure that conduits and cable trays feeding the Telecommunication Room terminate *completely inside* the TR.

F. Communications Distribution Systems (Pathways & Spaces)

(1) Definition

- a. Communications pathways and spaces are facilities used to distribute and support cable and connecting hardware between Equipment Rooms; and, between Equipment Rooms and the work area outlet. These spaces may include conduit, cable tray, open air plenums, cellular floor duct, etc.

(2) Backbone Communication Pathways

- a. Backbone communication pathways may consist of shafts, conduits, raceways, and floor penetrations (*i.e.* sleeves or slots) which provide routing space for communication cables.
- (3) Sleeves & Slots
- a. Vertically aligned TRs with connecting sleeves or slots are the most common type of backbone pathway.
 - b. Position cable sleeves or slots adjacent to a wall, which can support backbone cables. Sleeves or slots shall not obstruct wall terminating space. All sleeves and slots shall be constructed in accordance with the National Electrical Code (NEC) and local fire codes, and shall have curb, a minimum 2 inches high from the finished floor.
 - c. Design sleeves with a 4-in diameter, unless a smaller size is required by the structural engineer.
 - d. The following table provides general guidelines for determining the number of 4-in sleeves required, based on ANSI/EIA/TIA-569.

TOTAL SQUARE FEET	QTY- OF SLEEVES
Up to 50,000	3
50,000 to 100,000	4
100,000 to 300,000	5-8
300,000 to 500,000	9-12

- e. The following table provides general guidelines for determining the sizes of slots required, based on ANSI/EIA/TIA-569.

TOTAL SQUARE FEET	SIZE OF SLOT
Up to 250,000	6-in x 9-in
250,000 to 500,000	15-in x 46-in
500,000 to 1,000,000	23-in x 51-in
1,000,000 to 2,000,000	38-in x 61-in

- (4) Open Shafts
- a. Open shafts should only be used where large quantities of cables are required. Backbone cables should never be located in elevator shafts.
- (5) Conduit / Enclosed Metallic Raceways
- a. Conduit or enclosed raceways may be used to run cables “point to point” where intermediate splicing is not required, or where physical protection or enhanced security is required.
 - b. The following table indicates the “conduit fill ratio” based on area and the minimum bend radius. Apply these fill percentages to straight runs with nominal offsets equivalent to no more than two 90° bends.

CONDUIT			AREA OF CONDUIT			MINIMUM BEND RADIUS
Trade Size (in.)	Internal Diameter	Area = $.79D^2$ Total 100%	Maximum Occupancy A (1 Cable) 53% Fill	Maximum Occupancy B (2 Cables) 31% Fill	Maximum Occupancy C (3 or more) 40% Fill	10X Conduit Diameter
¾	0.82	0.53	0.28"	0.16"	0.21"	8
1	1.05	0.87	0.46"	0.27"	0.35"	11
1 ¼	1.30	1.51	0.80"	0.47"	0.60"	14
1 ½	1.61	2.05	1.09"	0.64"	0.82"	16
2	2.07	3.39	1.80"	1.05"	1.36"	21
2 ½	2.47	4.82	2.56"	1.49"	1.93'	25
3	3.07	7.45	3.95"	2.31"	2.98"	31
3 ½	3.55	9.96	5.28"	3.09"	3.98"	36
4	4.03	12.83	6.80"	3.98"	5.13"	40
5	5.05	20.15	10.68"	6.25"	8.06"	50
6	6.07	29.11	15.43"	9.02"	11.64"	60

(6) Horizontal Communication Pathways

- a. Horizontal distribution systems (or horizontal pathways & spaces) consist of structures that conceal, protect, and support horizontal cables between the communications workstation outlet and the horizontal cross-connect in the serving Telecommunications Room.
- b. Horizontal communications pathways are used to distribute and support horizontal cable and connecting hardware between the workstation outlet and the Telecommunications Room. These pathways & spaces are the "container" for the horizontal cabling.
- c. It is the responsibility of the designer to review all proposed horizontal distribution systems with the UIT project coordinator to ensure that the systems design:
 - i. Makes optimum use of the ability of the horizontal cabling system to accommodate change,
 - ii. Is as unconstrained as possible by vendor-dependence,
 - iii. Complies with ANSI/NFPA 70 (ref. 7.1), this Design Manual and University of Utah Supplement, Local, State, and Federal Codes, and,
 - iv. Complies with ANSI/EIA-TIA-569 (Ref. 7.20).

(7) Design Considerations

- a. Horizontal distribution systems shall be designed to accommodate diverse user applications including:
 - i. Voice Communications
 - ii. Data Communications

- iii. Local Area Networks (LANs)
 - iv. Wireless Applications
 - b. The designer shall also consider any other building information systems (*e.g.* CATV, building alarms / security, audio PA systems, etc.), which may require area/space in the horizontal distribution system, and shall allow for these systems accordingly.
 - c. An effective design of a building's horizontal distribution system should meet the following criteria:
 - i. All applicable local, state, and federal, codes.
 - ii. All applicable BICSI, ANSI, NFPA, EIA/TIA, UL, NEC, IEEE, ASTM, BOCA, FCC, SBC, ISO, and State adopted codes. Provide flexible cable distribution to workstation locations
 - iv. Facilitate ongoing maintenance
 - v. Easily accommodate future changes in equipment and services
 - vi. Minimize occupant disruption when horizontal pathways and spaces are accessed.
 - vii. A minimum of three cable runs per individual workstation.
 - d. The horizontal distribution system shall be designed to handle all types of communications cabling (i.e., UTP, STP, Coax, and Fiber Optic). When determining the type and size of the cable pathway, consider the quantity and size of the cables that the pathway is intended to house, and allow for growth of the area served over the planning cycle.
 - e. When designing the horizontal distribution system, it is important to consider adds, moves, and changes, and minimal disruption to immediate occupants.
- (8) Number of Cable Runs per Work Area
 - a. The pathway design should allow for a minimum of three cable runs per individual work area.
- (9) Electromagnetic Interference (EMI)
 - a. Because EMI causes severe problems with electronic equipment, telecommunications, and data communications, avoidance of all potential sources or electromagnetic interference shall be a primary consideration when designing a horizontal distribution system. To avoid electromagnetic interference, all distribution pathways should provide clearances of at least:
 - i. Four ft. (4' or 1.2 m) from large motors and/or transformers
 - ii. One ft. (1' or 0.3 m) from conduit and cables used for electrical power distribution
 - iii. Five in. (5-in or 12 cm) from fluorescent lighting
 - b. Horizontal distribution pathways should cross perpendicular to fluorescent lighting and electrical power cables or conduits.
 - c. For additional clearance requirements, see ANSI/EIA-TIA-569 and ANSI/NFPA 70.
- (10) Grounding & Bonding
 - a. Horizontal pathways shall be grounded and bonded in accordance with the requirements specified in ANSI J-STD-607-A, except where other codes or local authorities impose more stringent requirements.
- (11) Fire-Stopping

- a. Install removable fire pillows.
 - b. All horizontal pathways that penetrate fire-rated barriers must be sealed in accordance with applicable codes. Provide smoke rated protection as required for smoke rated wall and floor penetrations.
- (12) Administration of Horizontal Distribution Systems
- a. Utilize standard methods and procedures for labeling and managing horizontal pathways. Locate markings so that they are clearly visible after installation, and easily distinguishable from any markings that appear on individual components. For details on guidelines and requirements for the administration of horizontal pathways and spaces, see BICSI TDM Manual Chapter 4 and ANSI/TIA/EIA-606.
- (13) Types of Horizontal Distribution Systems
- a. Many types of horizontal distribution systems are acceptable for installation at the University of Utah. Many buildings may require two or more of the following systems to meet all distribution needs. Acceptable types of horizontal pathways are:
 - i. Unlimited access (raised floors).
 - ii. Ceiling zones and grids
 - iii. Cellular floors.
 - iv. Conduit
 - v. Underfloor ducts (one-level or two-level)
 - vi. Cable tray
- (14) Sizing of Horizontal Pathways
- a. The size requirements for horizontal distribution pathways depend on the following:
 - i. Usable floor space served by the pathway.
 - ii. Maximum occupant density (*i.e.*, floor space required per individual work area).
 - iii. Cable type and diameter.
 - iv. Pathway capacity (requires that the fill factor be taken into account).

TRADE SIZE	CABLE OUTSIDE DIAMETER (INCHES)										
	Inches	0.13	0.18	0.22	0.24	0.29	0.31	0.37	0.53	0.62	0.70
½	1	1	0	0	0	0	0	0	0	0	0
¾	6	5	4	3	2	2	1	0	0	0	0
1	8	8	7	6	3	3	2	1	0	0	0
1 ¼	16	14	12	10	6	4	3	1	1	1	1
1 ½	20	18	16	15	7	6	4	2	1	1	1
2	30	26	22	20	14	12	7	4	3	2	2
2 ½	45	40	36	30	17	14	12	6	3	3	3
3	70	60	50	40	20	20	17	7	6	6	6
3 ½	-	-	-	-	-	-	22	12	7	6	6
4	-	-	-	-	-	-	30	14	12	7	7

- b. The usable floor space (also referred to as "office space") is generally considered to be the building area used by the occupants for their normal daily work functions. For design purposes, this space should include hallways. All other common areas in the building should be disregarded.
- c. The occupant density or floor space allocation per office or individual work area for the University is 100 ft² of usable floor space.
- d. Cable Density. Design for pathway capacity to accommodate a minimum of three horizontal cable runs per workstation location.
- e. Cable Diameter: For planning purposes use the following table to determine the minimum amount of Horizontal Pathway Distribution capacity.

HORIZONTAL CABLE TYPE	TYPICAL OUTSIDE DIAMETER
Four-Pair Category 5, 100-ohm UTP	0.25 to 0.28 inches
Two-Pair Shielded Twisted Pair, 150-ohm STP	0.31 to 0.43 inches
Duplex 62.5/125pm Optical Fiber Cable	0.11 to 0.18 inches

- f. Conduit Capacity: Adequate planning should allow for a minimum of 1 inch conduits to each workstation location. Maximum conduit fill capacities shall not be exceeded in accordance with ANSI/NFPA 70, Chapter 9.

(15) General Conduit Distribution

- a. A horizontal conduit system consists of conduits radiating from the Telecommunications Room to the work station outlets in the floor, walls, ceilings, and columns of a building.

(16) Suitable Conduit

- a. The following types of conduit are deemed suitable for building installation at the University:
 - i. Flexible Metal Tubing - (limitations apply, obtain specifications and direction from the UIT project coordinator)
 - ii. Rigid metal conduit (typical two (2), 3/4 inch conduits to each workstation location for horizontal distribution).

(17) Conduit Runs

- a. Conduit runs should be designed for the most direct route, parallel to building lines, with no more than two (2), 90 degree bends between pull points or pull boxes. Design each run with a maximum horizontal cable run of ninety (90) meters (295 ft.). Continuous sections shall not be longer than thirty (30) meters without pull points or pull boxes installed.
- b. It is recommended that conduit runs be kept to no more than 45 meters (150 ft.) in total length including sections through pull boxes.

(18) Conduit Quantity and Size

- a. A minimum of two (2), 3/4-inch metal conduits shall be installed from the Telecommunications Room and terminated to each four square workstation outlet.
- b. Include in the design, the installation of one 3/4" metal conduit from the Telecommunications Room to termination at each wireless access point.

(19) Conduit Bend Radii

- a. The radius of a conduit bend shall be at least 6 to 10 times the diameter of the conduit. Conduits designated for Futureflex tubing shall be installed with a minimum bend radius of 12 times the diameter of the conduit.
- (20) Conduit Entering Telecommunications Rooms
- a. Horizontal distribution conduits entering a Telecommunications Room should terminate near the corners and allow for proper cable racking. If conduits are entering through the floor, they must terminate four inches (4") above the finished floor. If conduits are entering through a wall, the conduits must be reamed and bushed, and terminated as close as possible to the terminating rack or wall.
- (21) Completing Conduit Installation
- a. Upon completion of Horizontal Distribution Conduit, the conduits will be:
 - i. Left clean, dry and unobstructed
 - ii. Capped for protection
 - iii. Labeled for easy identification
 - b. All conduits will be equipped with a contiguous length of plastic or nylon pull string with a minimum rating of 200 lbs. (90 Kg) or a 12 AWG wire.
- (22) General Cable Tray Systems
- a. Cable tray systems are used primarily as main corridor distribution apparatus. Cable tray systems should be designed as equipped to support only telecommunications and data communications cable. Shared systems with power are not acceptable under the guidelines listed in avoiding EMI.
- (23) Suitable Cable Tray Systems
- a. The following cable tray systems are acceptable for installation at the University:
 - i. Channel
 - ii. Ladder
 - iii. Solid Bottom
 - iv. Trough
 - v. Wire Mesh (basket), dual hung with no center support
- (24) Cable Tray Runs
- a. Cable tray systems should be installed with a minimum number of bends installed, if more than three 15 degree turns are installed in a contiguous length, then de-rate the effective capacity of the cable tray by twenty-five (25) percent. Delineations in a level cable tray installation are often unavoidable, however these delineations should be kept at a minimum with each delineation not exceeding 30 degrees and 24 inches offset. The total delineation for the tray span should not exceed 180 degrees.
- (25) Cable Tray Size and Capacity
- a. Cable tray size and capacity will be determined by the amount and type of cable installed, the static load capacity of the tray, and the length of the support span. Cable tray systems should be designed to accommodate 100 percent future growth.
- (26) Cable Tray Installation Clearance
- a. Cable tray systems are to be installed with as much clearance as possible from other building facilities, and installed in the lowest position below all other building facilities but above the ceiling grid, in accordance with ANSI/NFPA standards and meeting the following criteria:

- i. 8 in. clearance from obstructions on both sides.
 - ii. 8 in. clearance from obstructions to the top.
 - b. Installation of cable tray pulley systems installed in a solid ceiling environment should provide access points at 20 ft. on-center, and at any directional deviation greater than 15 degrees and/or 90 degree turns.
- (27) Cable Tray Entering Telecommunications Rooms
 - a. Cable tray entering a Telecommunications Room should wrap around the room and allow for proper cable racking.
- (28) Completing Cable Tray Installation
 - a. Upon completion of horizontal cable trays, the trays shall be inspected by the designer to verify that the trays are:
 - i. Free and clear of all obstructions and debris
 - ii. Free of burrs, sharp edges, and projections
 - iii. Labeled for easy identification
 - iv. Identified as "Telecommunications Cable Tray Only"
- (29) Other Types of Horizontal Distributions Systems
 - a. The university has identified other types of acceptable horizontal distribution systems that may be installed. These include, but are not limited to:
 - i. Unlimited access (raised floors).
 - ii. Ceiling Zones and Grids
 - iii. Cellular Floors.
 - iv. Conduit
 - v. Underfloor ducts (one-level or two-level)
 - b. Due to the individuality, complexity, and the broad scope of requirements for these systems. UIT will review each of these specified systems on a 'case-by-case' basis.
- (30) Outlet Boxes, General
 - a. Telecommunications outlet boxes installed in dry-wall, plaster, or concrete block wall shall be single gang plaster (mud) rings. Wall phones and wireless connections shall use single gang plaster (mud) rings.
- (31) Mounting Outlet Boxes, Office Environment
 - a. Outlet boxes installed in an office environment must be specified to meet the following criteria:
 - b. At least 4 in² by 2-1/8 in. deep
 - c. Mounted at least 18 inches above the finished floor or even with adjacent electrical duplex services
 - d. Outlet boxes shall not be placed back to back
- (32) Mounting Outlet Boxes, Above Counters
 - a. Outlet boxes installed above a counter will meet the following criteria:
 - i. Counter with Backsplash: At least 6 inches above the top of the counter to the center of the outlet.
 - ii. Counter without a Backsplash: At least 12 inches above the top of the counter to the center of the outlet.
- (33) Mounting Outlet Boxes, Wireless

- a. At least 4 in² by 2-1/8 in. deep
 - b. Mounted at 10 inches below the finished ceiling
 - c. Outlet boxes shall not be placed back to back
 - d. Distance between units determined by the project designer
- (34) Elevator Phone
- a. Elevator phones on campus are installed and maintained by UIT.
- (35) Communication Connection
- a. Include in specifications that the Contractor will be responsible for the installation of the traveling cable from the elevator panel to the Car Operating Panel (“COP”). A minimum of four (4) 18 gauge wires will be provided in the traveling cable for the purpose of communication services transport. The communication wires will extend from the COP to the access panel opening that is provided for the communication device.
- (36) Conduit
- a. The Contractor shall provide a home run 3/4-inch conduit extending from the top of the elevator panel and extending to the nearest Telecommunication Room (TR or ER). UIT will provide the necessary cable to connect the emergency line to the elevator panel.
- (37) Communication Device
- a. The elevator communication device (phone panel) will be a standard design and configuration per drawing Detail COM-1. The ‘back-box’ is required per the drawing. The University UIT Department will furnish and install the device. The approved device for elevator installation is Ramtel Corporation Model RR833. The unit is a stainless steel, brushed finish panel which meets ADA requirements. The minimum required opening that shall be provided for the approved device is 9 1/4" H x 6-5/8" W with a minimum 4-inch clearance for the back of the device.
 - b. The elevator car is to be factory prepared for this device; or, the Contractor shall prepare the car to receive the device per Detail COM-1. Note that the device shall be mounted at a height which positions the activation button no higher than 48-3/4" above the finished floor.
- (38) Emergency Service Line
- a. The telephone line that is used in the elevators is a standard Centrex line that automatically rings to Public Safety.
 - b. It is the responsibility of the University Project Manager to order the line for the elevator and to notify Public Safety that a new elevator phone is being added to their system.
- G. Security Systems
- (1) Access Control and Intrusion Detection
- a. System
 - i. The Access Control and Intrusion Detection system is the Software House CCure system which includes a microprocessor based and managed access control system, with options for intrusion detection, and personal protection (duress) security and specifies sensors, detection devices, signal equipment, system controls, and displays. Each system installed will utilize either the iSTAR Pro or iSTAR Edge Controllers, or designated dialer.

- ii. The system shall tie into the existing CCure access control system currently installed on the University Campus.
- iii. The system shall have access controlled doors as well as perimeter doors and hatches monitored with door position switches.
- iv. The system shall interface with the fire alarm system and in the event of an alarm, shall unlock all controlled doors designated for emergency egress.
- v. Any card access component of this system shall be an extension of the existing campus-wide CCure access control system utilized by the University of Utah for all their facilities, with all existing functions available and be completely compatible with the then current version of the CCure system installed.
- vi. Duress alarm: Performed by indicated hard wired stationary duress alarm button locations and remote wireless receivers that are triggered by portable transmitters.
- vii. Alarm Annunciation: In addition to the audible signal sounds and visual text indication on the system keypad, video images from associated cameras in the area may, at the election of Facilities Central Services, be called up immediately and automatically to an assigned workstation for viewing. No additional operations for video call up by the control officers shall be necessary. Provide all licensing as required for CCure system and video system to perform automatic video camera call up via event programming in CCure.
- viii. Battery backup for all components in security system shall be capable of operating for a minimum of 8 hours in the event of a power failure.
- ix. Security contractor shall interface ADA openers where security access control is installed to allow for proper ADA access/egress as per building code.

(2) Testing

- a. The campus Facilities Central Services Office will perform final system testing. Contractor shall provide notification to Project Manager that system is complete and ready. Project Manager will schedule the final testing with the University Facilities Central Services.

(3) Warranty

- a. Specify two-year warranty to repair or replace components of access control and intrusion detection devices and equipment that fails in materials or workmanship. Warranty should be started upon completion of final walk through and sign off with University Facilities Central Services.

(4) Equipment

- a. Equipment specified for the CCure system will be required to use the approved University Parts list. The Parts list can be found in [6.0](#).
- b. Surge Protection: Comply with minimum requirements of UL Standard 1449, "Transient Voltage Surge Suppressors," for each component using solid-state devices and having a line voltage power source connection or an exterior underground signal connection.
- c. Controllers: Provide at the locations identified, a complete and CCure System including but not limited to the following equipment:

- i. iSTAR Pro or iSTAR Edge controller: iSTAR Pro controllers can be purchased and installed as either an 8 door package or a 16 door package. The Altronix Power Supply AL300ULX can be used for powering 2 iSTAR Pro controllers when they are installed in the same room.
 - ii. For a list of approved parts for the 16 and 8 Reader Front End Package Equipment refer to the University Parts list. The Parts list can be found in [6.0](#).
 - iii. I-class Card Readers
 - iv. Relay Output Contact
 - v. Motion Detectors
 - vi. Request to Exit Devices
 - vii. Door Contacts
 - viii. Power Supplies and Transformers
- d. Magnetic Door Locks
 - i. Magnetic door locks shall not be used within alarm and access systems at the University
- e. Power Supplies
 - i. Provide power supplies as per manufacturers written recommendations with total number of powered devices for each power supply restricted to only consuming 75 percent of the power supplies rated amperage. Provide separate power supplies for system controllers (As per manufacturer), card readers (12VDC, 5A), and locks (24VDC, 7A).
 - ii. 120V 60Hz from locked disconnect device. System components are supplied with power through separate power supplies. Provide all required power supplies and associated transformers as specified by the manufacturer and required for the installation.
 - iii. Power Source Transfer: When normal power is interrupted, system is automatically switched to backup supply without degradation of critical system function or loss of signals or status data. Whenever possible, the system should be tied to the building's emergency power.
 - iv. To ensure adequate power, installer shall calculate the total power requirements of the iSTAR Pro controller and related hardware. If the maximum power consumption exceeds the output of the iSTAR Pro power supply, an additional power supply shall be connected to the system.
- f. Card Access System Hardware
 - i. The access control panel (iSTAR Pro and/or iSTAR Edge controller) shall be provided and wired with back-up battery power for a minimum of 8-hours operation upon loss of AC power.
 - ii. The access control panel shall have provisions for relay suppressor kits for each relay used, to protect the access control panel from collapsing electrical fields.
 - iii. Card readers shall be HID Prox-Pro and HID Mini-Prox readers matching the readers currently installed on campus for door control. The access control panel shall support card readers using Wiegand, Proximity and Biometrics technologies.

- g. Door and Window Switches
 - i. Balanced-magnetic switch, complying with UL 634, installed on frame with integral overcurrent device to limit current to 80 percent of switch capacity. Bias magnet and minimum of [two] [three] encapsulated reed switches shall resist compromise from introduction of foreign magnetic fields.
 - ii. Position switches on doors shall be magnetic reed switch type and shall be per manufacturers recommendations for the type of door installed on. Provide concealed door frame types.
 - iii. Flush-Mounted Switches: Unobtrusive and flush with surface of door and window frame.
 - iv. Overhead Door Switch: Balanced-magnetic type, listed for outdoor locations, and having door-mounting magnet and floor-mounting switch unit.
 - v. Remote Test: Simulate movement of actuating magnet from central station control unit.
- h. Exit Request Devices
 - i. Passive Infrared (PIR) Devices: Detect request to exit by monitoring infrared energy emitted within the door exit zone. Units are sensitive to the infrared wavelengths emitted by the human body and are insensitive to general area thermal variations.
 - ii. On door types (see drawing schedules) that do not show motion detectors being used, the request to exit function will be handled by the switched exit hardware devices. It shall be the responsibility of the security contractor to coordinate with the hardware contractor in wiring of power transfer hinges and switched exit devices. The only doors that do not require any exit request are doors with a reader on both sides.
- i. Acoustic Type, Glass-Break Sensors
 - i. Sensor Element: Microprocessor-based, digital device to detect breakage of plate, laminate, tempered, and wired glass while rejecting common causes of false alarms. Detection pattern shall be at least a 20-foot (6-m) range.
 - ii. Hookup Cable: Factory installed, not less than 72 inches (1830 mm).
 - iii. Activation Indicator: LED that lights on sensor housing when responding to vibrations, remaining on until manually reset at sensor controller or at central- station control unit.
 - iv. Controller: Integral with sensor housing or in a separate assembly, locally adjustable by control under housing cover.
 - v. Glass-Break Simulator: A device to induce frequencies into protected glass pane that simulate breaking glass without causing damage to glass.
- j. Photoelectric Sensors
 - i. Sensitivity: Detect standard-intruder movement within sensor's detection patterns at any speed of less than 7.5 fps (2.3 m/s) though the beam. Allow installation of multiple sensors within same protected zone that will not interfere with each other.
 - ii. Activation Indicator: LED indicator shall not be visible during normal operation. Indicator shall light when sensor detects a standard intruder. Locate test enabling switch under sensor housing cover.
 - iii. Remote Test: When initiated by central-station control unit, start a

test sequence for each detector element that simulates standard intruder movement within sensor's detection patterns, causing an alarm.

- k. Microwave Pir Dual Technology Motion Sensors
 - i. Single unit combining a sensor that detects changes in microwave signals and a PIR sensor that detects changes in ambient level of infrared emissions caused by standard-intruder movement within detection pattern.
 - ii. An alarm is transmitted when either sensor detects a standard intruder within a period of three to eight seconds from when the other sensor detects a standard intruder.
 - iii. Minimum Detection Pattern: A room 30 by 30 feet.
 - iv. PIR Sensor Sensitivity: Adjustable pattern coverage to detect a change in temperature of 2 deg F (1 deg C) or less, and standard intruder movement within sensor's detection patterns at any speed between 0.3 to 7.5 fps (0.09 to 2.3 m/s) across 2 adjacent segments of detector's field of view.
 - v. Microwave Sensor Sensitivity: Adjustable, able to detect standard intruder movement within sensor's detection pattern at any speed between 0.3 to 7.5 fps (0.09 to 2.3 m/s). Sensor sensitivity adjustments shall be accessible only when sensor housing is removed, and sensors shall comply with 47 CFR 15.
 - vi. Activation Indicator: LED indicator shall not be visible during normal operation. Indicator shall light when sensor detects a standard intruder. Locate test enabling switch under sensor housing cover.
 - vii. Remote Test: When initiated by central-station control unit, start a test sequence for each detector element that simulates standard intruder movement within sensor's detection patterns, causing an alarm.
 - l. Wire and Cable
 - i. Provide both TPS (Twisted pair Shielded) and TP (Twisted Pair), with the appropriate number of pairs. Provide Cat 5e UTP for emergency telephone signal wiring.
 - ii. Cable for Low-Voltage Control and Signal Circuits: shall be shielded twisted-pair cable with drain.
 - iii. HID Card Reader-Weigand-Composite cable part number CSC #702790.
 - (a) 1-22/6 conductor overall shield (Reader)
 - (b) 1-18/4 conductor (Lock Power)
 - (c) 1-22/2 conductor (Door Contact)
 - (d) 1-22/4 conductor (Request to Exit)
 - iv. RM Style Card Reader-RS485-CSC#112102
 - (a) 1-18/2 pair individually shielded
 - v. Inside Card Reader on IN/OUT Door-Weigand-CSC#110253
 - (a) 1-22/6 conductor overall shield
 - vi. Alarm Door Contact-CSC#110105
 - (a) 1-22/2 conductor
 - vii. Duress/Panic Button-CSC#110105
 - (a) 1-22/2 conductor
 - viii. RM input/output Modules-RS485-CSC#112102
 - (a) 1-18/2 pair individually shielded
- (5) Installation Requirements for Wiring

- a. Install all wiring in raceways
 - b. ¾ inch minimum conduit is required
 - c. Multiple home runs may be contained in a single conduit of appropriate size.
 - d. Conceal raceways except in unfinished indoor spaces.
 - e. Conduit fill shall not exceed 40%.
 - f. Wiring shall be neat and workmanlike.
 - g. Cables shall be individually labeled.
 - h. Cable Central Services using spools, guides, supports and other devices.
 - i. Cable shielding and grounding SHALL be utilized in panels and enclosures.
 - j. Shield grounding SHALL be at the panel and NOT at the device (to avoid ground loops)
 - k. Cable routing within the enclosure or panel shall be neat and workmanlike.
 - l. Number of terminated conductors shall be in accordance with manufacturers' recommendations and/or requirements.
 - m. Un-terminated conductors shall be electrically isolated and secured within the enclosure or panel.
 - n. Appropriate splices, taps or terminations shall be in an approved junction box.
 - o. External device power supplies shall be installed in Facilities Central Services approved locations.
- (6) Naming and Programming
- a. Convention:
 - i. Use the official University campus building numbers, and the University designated room numbers.
 - ii. Descriptive abbreviations should be used as most CCure program display boxes are limited in size.
 - b. iSTARs:
 - i. Building Number: iSTAR Number L#
Door# Room Description Ex: 0003:03
L1 0166 Northwest Comm Rm
0079:02 L2 2000D L2 Data Closet 0525:19 L4
East Comm Rm by Elevator.
 - ii. A more complete description of the iSTAR's location, access requirements (card access, key number, how to find the room where the iSTAR is located, etc.) should be entered in the description section of the configuration identification screen.
Ex.; Located on level one, room 1001, (or across from elevator) using key RT2674 or access card.
 - iii. Programming:
 - (a) Leave time zone box blank.
 - (b) Tamper, AC power fail and Low Battery inputs should all be defined and properly working.
 - (c) An event should be defined for controller communication failure.
 - c. iSTAR Clusters:

- ii. A more detailed description should be entered if the cause of the event or required action to the event needs to be displayed on the General Activity Monitor screen.
 - b. Clearance:
 - i. Naming: Building Number – Partition name if other than default, Description, (type) – (IZ-intrusion zone, PH-pharmacy, etc.), time range (D-D 0000-0000)
 - (a) Ex: 0093 Natatorium Men’s Pool Entry Clr 0179 Ext Ent M-F 0800-1700 Clr
 - ii. The type and/or location of the doors in the clearance should be clear.
 - c. Schedule:
 - i. Naming: Building Number: iSTAR number (if applicable for event activation) – Description, time range (D-D0000-0000)
 - (a) Ex: 0053:01 Disability Center Unlock M-F 0800-1700 Scd 0722:02 Shop Area Force Arm M-S 2200 Scd 0086 Custodial Day M-F 0600-1500 Scd
 - (b) Since there is no place for a detailed description, the time specification name should supply as much information in as an abbreviated form as possible.
 - ii. Programming:
 - (a) The time zone box shall be left blank when defining a time specification.
 - d. Groups:
 - i. Naming: Building Number: Floor (if applicable):Description
 - (a) Ex: 0512 Ext Door Grp for door group 0556 Patient ElevGrp for elevator group 0865 EvtGrp for event group 0064 InputGrp for input group 0035 OutputGrp for output group
 - (b) There is a description box that can be used to clarify particular group information if necessary
- (8) Grounding
- a. Manufacturer's Field Services: Provide services of a factory-authorized service representative to supervise the field assembly and connection of components and system pre-testing, testing, adjustment, and programming.
 - b. Inspection: Verify that units and controls are properly labeled and interconnecting wires and terminals are identified.
 - c. Pre-testing: Align and adjust the system and perform pre-testing of all components, wiring, and functions to verify conformance with specified requirements. Correct deficiencies by replacing malfunctioning or damaged items with new items. Retest until satisfactory performance and conditions are achieved.
 - d. Testing: Provide at least 10 days' notice of acceptance test performance schedule.
 - e. Operational Tests: Perform operational system tests to verify conformance with specifications. Test all modes of system operation and intrusion detection. Methodically test for false alarms in each zone of space intrusion devices by simulating activities outside indicated detection patterns.
 - f. Installer Start-up Responsibility: The Installer shall initiate system operation. The

Installer shall provide competent start-up personnel until the system is fully functional. Upon reoccurring technical problems, the Installer shall supply factory University Design Requirements direct Manufacturer's support in the form of factory technical representation and/or diagnostic equipment until the resolution of those defined problems.

- g. Final testing shall be observed by a representative of the campus Facilities Central Services Office. Complete security system shall be approved and accepted by Facilities Central Services.

H. Video Surveillance Systems

(1) General

- a. The contractor or sub-contractor installing the video system must be qualified and trained to OnSSI standards and Axis certified.
- b. Video Central Services systems shall integrate with the Software House CCURE 9000 software. The IP video surveillance control and Central Services system shall handle an unlimited number of cameras and alerts through a desktop-based or mobile video client.
- c. The contractor or sub-contractor installing the video system shall be qualified and trained to OnSSI standards and Axis certified.

(2) Warranty

- a. Manufacturers standard form in which manufacturer and Installer agree to repair or replace components of video surveillance devices and equipment that fails in materials or workmanship within specified warranty period which is two years from date of final walkthrough and sign-off by Facilities Central Services.

(3) Equipment

a. Video Surveillance Wire/Cable

- i. The primary cabling is Ethernet cabling, either Cat 5 or Cat 6. Cat 6 cable shall be used for any new or replacement cable installations. Additional cable may be required for the environmental controls of outdoor housings or additional power requirements for PTZ (Pan-Tilt-Zoom) cameras. However, as cameras have continued to evolve, the additional power required for these (Power-Over-Ethernet) standard. Any deviation shall require approval from Facilities Central Services prior to installation of substitute cabling. Ethernet extenders may be used in rare circumstances to provide reliable connectivity. Use of extenders shall be approved by Facilities Central Services during the design process.

b. Video Surveillance Equipment

- i. The University has standardized on the Axis product line for video surveillance. Common Axis camera models used by the university are listed. Other camera models may be required for specific surveillance purposes, but shall contain the remote focus feature. However, any substitution or deviation from Axis camera products, or these specific Axis models, shall be approved by Facilities Central Services prior to installation.

- (a) Legacy analog camera conversion: existing camera installations can be converted to the Ocularis OnSSI system with the addition of conversion hardware. While replacement of analog cameras with newer high-definition models is preferred, the following hardware shall be used in situations where analog camera images are determined to be sufficient.

c. OnSSI Video Software and Hardware

- i. Facilities Central Services maintains the centrally managed servers the Ocularis Surveillance system as well as the appropriate server(s) for the cameras at various locations throughout the campus. Installations/conversions of fewer than 8 cameras will record to existing Ocularis servers. Installations/conversions of 9 or more cameras will require an additional recording server which will be supplied and maintained by Facilities Central Services. Cost of these servers is covered within monthly camera fees already billed to the departments.
 - ii. Video Monitoring Workstations require a minimum of:
 - (a) CPU: Intel core i7 (similar or better)
 - (b) RAM: 8GB
 - (c) Operating System: Microsoft Windows 7 Professional 64- bit.
 - (d) Graphics Adapter: PCI-Express, 1GB RAM w/dual DVI outputs 35 simultaneous Video Channels –1GB
 - (e) Software: Microsoft .NET 3.5 Framework and DirectX 9.0 or newer.
 - iii. Switches: All IP camera installations shall be connected to a campus standard PoE rated switch.
 - d. Raceways, Electrical Boxes, and Fittings shall be per 3.5 Electrical.
- (4) Installation
 - a. Install video surveillance systems and components where indicated, in accordance to NFPA 70, with equipment manufacturer's written instructions, in compliance with National Electrical Code, and with recognized industry practices, to ensure that video surveillance system complies with requirements and serves intended purposes.
 - b. Wiring Method: Install all wiring only in raceways, 3/4" minimum, or cable trays. Multiple home runs may be contained in a single conduit of appropriate size. Conceal raceways except in unfinished indoor spaces. Conduit fill shall not exceed 40%.
 - c. Wiring within enclosures: Label, bundle, wrap, and train the conductors to terminal points with 6-inches of slack minimum, 12-inches of slack maximum. Provide and use cable Central Services hardware and distribution spools. Wire shielding, where used, should remain un-cut as much as possible.
 - d. Number of Conductors: As recommended by system manufacturer for functions indicated.
 - e. Splices, Taps, and Terminations: Make splices, taps, and terminations on numbered terminal strips in junction, pull and outlet boxes, terminal cabinets, and equipment enclosures.
 - f. Tighten connections to comply with tightening torques specified in UL Standard 486A.
 - g. Identification of Conductors and Cables: Color-code conductors and apply wire and cable marking tape to designate wires and cables so media are identified and coordinated with system wiring diagrams.
 - h. Install power supplies and other auxiliary components for camera devices at the locations pre-approved by Facilities Central Services.
- (5) Grounding
 - a. Ensure that any power supplies are properly connected to an earth ground near the AC input wiring.

- b. For devices appropriate for cable shield grounding, ensure that any shield wires are grounded at the power supply end of the cable to the ground referenced above.
- c. Do NOT connect the shield to ground at the far end cabled device. (This will avoid the potential for “ground loops”.)
- d. When disconnecting wiring, disconnect ground wires last (to provide maximum protection to the equipment and personnel.)

4.0 LANDSCAPE AND IRRIGATION STANDARDS

The DFCM Landscape and Irrigation Standards shall be followed on all University projects, along with the additional University requirements detailed below.

4.1 General

A. Applicability

- (1) All landscape designs prepared for the University shall include the general and specific requirements described in this supplement, and include applicable graphics located in the section containing the detail drawings.
- (2) The purpose of this supplement, including the detail drawings, is to acquaint the design consultant (Landscape Architect, herein referred to as "A/E") with these University specific landscape and irrigation requirements, as established by the University Department of Landscape Maintenance.

B. Site

- (1) The University is situated on a 1,500-acre site, encompassing 600 developable acres. The site supports over 300 buildings. Since moving to its current location in 1900, the University campus has evolved into a 'look' and 'feel' identifiable as "The U of U." A mission objective of the University Department of Landscape Maintenance is to ensure that the University's identity and setting is applied consistently in the design of campus green space.

C. Purpose

- (1) Over years of campus evolution, the Landscape Maintenance Department has evaluated, and continues to evaluate products, materials, and methods of irrigation and plantings in support of a cost effective, low maintenance landscape infrastructure which maintains the traditional University identity. Products, materials, plants, and system assemblies described herein and in the detail drawings have been selected to standardize campus landscape and irrigation systems; minimize the stocking of parts from multiple manufacturers; and, efficiently conserve University energy, water, and maintenance resources.

D. Definitions

- (1) University Landscape Reference Standards
 - a. Use plant names in the specifications obtained from "Standard Plant Names" or "Bailey's Encyclopedia of Horticulture." When a name is not found in either reference, consult local resources from the nursery trade for a name which will not confuse local landscape contractors. Refer to the University Plant List, [4.3 A \(4\)](#).
- (2) Tree and Planting Specifications
 - a. Tree and planting guidelines are to be specified in accordance with ISA (International Society of Arboriculture), Utah State University Extension Service (Extension Forester), and the U.S. Department of Agriculture, except where the requirements herein are more restrictive.
- (3) Plant Tagging Requirements
 - a. Require all plants to be tagged by the supplier nursery with the identification labels consistent with the specified plant names and project drawing identifiers if drawing symbol identifiers are used.

E. Designer(s)

- (1) No additional University design requirements.
- F. Contractor Qualifications and Experience
- (1) Require at least one registered Certified Irrigation Contractor (CIC), with a current certification from the Irrigation Association to be included in the Contractor's work crew as a direct employee of the Contractor. The CIC will be required to meet weekly with the Irrigation Foreman of the University Landscape Maintenance Department to walk the work site and review the progress of the Work.
- G. Submittals
- (1) Joint A/E and Facilities Management Site Meeting
 - a. When the building footprint is known, and prior to submission of the design development drawings, coordinate with the University Project Manager to arrange a site meeting with the University Project Manager and the University Landscape Maintenance Department.
 - b. Existing site conditions and A/E's proposed improvements will be evaluated at the meeting.
 - c. Trees and other site vegetation, both within the intended construction site limits and adjacent to the construction site, will be evaluated. Roots from adjacent trees and vegetation which could be damaged by construction activities (*i.e.*, vehicular traffic, lack of water, excavation, etc.) will be addressed.
 - d. Analyze access routes for equipment, staging locations, and temporary storage areas likely to affect the site.
 - e. Inventory the trees within the contract limit lines. Record the location, size, and health of each tree to be saved. Identify trees which will require pruning to allow for future structure.
 - f. Photograph each tree to establish a base line health status and condition of the tree before construction.
 - g. Estimate the size of the protection zone for each tree and determine the feasibility of fencing the affected trees at the protection zone line. Show the protected zone areas on the project drawings.
 - h. Information gathered at the site meeting will be used to establish the following:
 - i. The environmental value of special vegetation and trees in and around the project site will be considered.
 - ii. The Department of Landscape Maintenance will provide the specific terms to be included in the project documents regarding tree replacement (both for intended replacement and for unintended loss). See [4.3 B \(2\)](#).
 - iii. The Department of Landscape Maintenance will identify the current dollar value for each tree remaining on site. The A/E shall insert tree value(s) in the drawings and specifications. See [4.3 B \(1\)](#).
 - iv. The Landscape Maintenance Department will provide special care instructions for existing vegetation to remain. These shall be included in the project documents. See paragraph e) herein. Examples of tree protections methods are provided in [4.3 B \(4\)](#).
 - i. The A/E shall prepare minutes of the meeting to record specifics for each tree. The A/E shall distribute the minutes to the University Project Manager and Landscape Maintenance Department.

H. Construction Inspection and Post-Construction Monitoring

- (1) Instruct the Contractor that landscaping work shall be suspended at any time when it may be subject to damage by climatic conditions. However, no substantial work suspension may be made without permission of the A/E and University Project Manager.
- (2) Any plant not alive, in poor health, or in poor condition at the end of the guarantee period will be replaced immediately. All replaced plants shall be guaranteed and maintained according to the specifications for another four (4) consecutive growing months (growing months to be defined as April, May, June, July, August and September).

4.2 Water Allowance

- A. No additional University design requirements.

4.3 Landscape Design Standards

A. Landscape Plan

(1) Plant Selection

- a. For University projects, the A/E is to specify drought resistant plants per the [4.3 A \(4\)](#), and as directed by the Landscape Maintenance Department.
- b. The A/E is to meet with the Landscape Maintenance Department to review all plants intended for the site prior to bid. As part of the review, any proposed plant which is not on the University Plant List shall be specifically presented to the Supervisor of the Landscape Maintenance Department. If approved, a written notice of approval shall be forwarded to the University Project Manager (and DFCM Representative if applicable) prior to bid.
- c. Specified plants shall be sound, healthy, vigorous, and free from pests and diseases. They shall be well branched, be in full leaf, and have a healthy root system. All plants specified shall be nursery grown. Require the Contractor to obtain plants which conform to specie and size specified.

(2) Maintenance of Plant Materials

- a. The specifications will require the Contractor to be responsible to maintain all planted materials in a healthy and growing condition for a period of any four (4) consecutive growing months (growing months to be defined as April, May, June, July, August and September).
- b. Specify this maintenance to include weeding, cultivating, fertilizing, monitoring water schedules, controlling insects and diseases, re-guying and staking, and all other operations of care necessary for the promotion of root growth and plant life so that all plants are in a condition satisfactory to the University at the end of the guarantee period.
- c. The specifications shall state that the Contractor shall be held responsible for failure to monitor watering operations and shall replace any and all plant material that is lost due to the improper application of water.

(3) Plant Material

- a. For University of Utah projects, the name and address of the source(s) or supplier(s) for all plant materials shall be furnished to the University Project Manager and A/E prior to the delivery of any plant materials.
- b. All plant materials are to be inspected by the A/E at the time of delivery on site. This inspection does not constitute final acceptance of any plant material. All plant material will be inspected again at time of final inspection and once again at the end

of the warranty period. Include in project specifications that any plant found to be unacceptable at any of these inspections shall be immediately removed and replaced.

- c. The A/E shall monitor the project and confirm that no unauthorized substitutions are present. If such are found, the A/E is to reject the material and require immediate replacement. If proof is submitted that specific plants or plant sizes are unobtainable, consider written substitution requests for the nearest equivalent plant or size. All substitution requests shall be made in writing and preferably before the bid due date. Review any substitution request with the Landscape Maintenance Department before taking action.

(4) University Plant List

BOTANICAL NAME	COMMON NAME
DECIDUOUS TREES	
Acer sp	
Acer ginnala	Amur Maple
Acer grandidentatum	Bigtooth Maple
Acer griseum	Paperbark maple
Acer palmatum	Japanese Maple
Acer palmatum dissectum	Lace leaf Maple
Acer platanoides	Norway Maple
Acer rubrum	Red Maple: Brandywine. Red sunset
Acer saccharinum	Sugar Maple
Acer tatarica	Tatarian Maple
Acer truncatum	Shantung Maple or Purpleblow
Aesculus X carnea	Red Horsechestnut
Albizia julibrissin	Misosa, Silk Tree, Albizia
Amelanchier alnifolia	Saskatoon, Western Serviceberry
Amelanchier arborea	Downy Serviceberry
Amelanchier grandiflora	Autumn Brilliance
Amelanchier laevis	Princess Diane Serviceberry, Cole's Select Serviceberry, Laevis Serviceberry
Amerlancier utahensis	Utah Serviceberry
Betula nigra	River Birch
Betula papyrifera	Paper Birch
Betula occidentalis	Betula fontinalis
Carpinus betulus 'fastigata'	European Hornbeam

BOTANICAL NAME	COMMON NAME
DECIDUOUS TREES	
Catalpa Sp.	Northern Catalpa
Cercidiphyllum japonicum	Katsuratree
Cercis canadensis	Eastern Redbud or Judas Tree
Cercis occidentalis	Western Redbud
Cercocarpus intricatus	Littleleaf mountain mahogany
Cercocarpus ledifolius	Curlleaf Mountain Mahogany
Chilopsis linearis	Desert Willow
Cladrastis lutea kentuckea	Yellowwood
Cornus florida	Flowering Dogwood
Cornus kousa	Kousa Dogwood
Cornus sericea & alba	Red-osier or Red-Stemmed Dogwood
Corylus colurna	Turkish Filber, Turkish Hazel
Cotinus coggygia & obouatus	Smoketree
Crataegus sp.	Hawthorn; Paul Scarlet
Eucommia ulmoides	Hardy rubber tree
Fagus sylvatica cultivars	European Beech
Fraxinus	Ash
Ginkgo biloba	Ginkgo, Maidenhair Tree
Gleditsia triacanthos var. inermis	Thornless Honey Locust
Koelreuteria paniculata	Goldenraintree
Laburnum X watereri	Goldenchain tree, Waterer Laburnum
Larix decidua	European Larch
Liriodendron tulipifera	Yellow-Poplar, Tuliptree, Tulip Poplar
Maackia amurensis	Amur Maackia
Magnolia x loebneri	Magnolia
Magnolia x soulangiana	Saucer Magnolia
Magnolia sprengeri	Sprenger Magnolia
Magnolia stellata	Star Magnolia
Malus,	Flowering Crab, Prairiefire(pink) -Flowering Persistant Only, springsnow(white)
Porsha mexicana	Clifforse, Quininebush
Prunus sp	

BOTANICAL NAME	COMMON NAME
DECIDUOUS TREES	
<i>Prunus maackii</i>	Amur Chokecherry
<i>Prunus virginiana</i>	Common Chokecherry
<i>Pyrus Calleryana</i>	Flowering Pear - red spine
<i>Quercus</i> sp.	
<i>Quercus gambelii</i>	Gambel Oak/Scrub Oak
<i>Quercus macroparpa</i>	Bur Oak
<i>Quercus robur</i> 'fastigiata'	English Oak
<i>Quercus shumardii</i>	Shumard Red Oak
<i>Quercus virginiana</i>	Live oak
<i>Robinia neomexicana</i>	New Mexico Locust
<i>Sorbus</i> sp.	Mountain Ash
<i>Tilia americana</i>	American Linden or Basswood
<i>Ulmus</i> 'Frontier'	Frontier Elm
<i>Ulmus glabra</i> 'camper downii'	Camper Down
<i>Ulmus parvifolia</i>	Lacebark or Chinese Elm
<i>Yucca brevifolia</i>	Joshua Tree
<i>Zelkova serrate</i> 'Schmidtlow'	Wireless Zelkova

BOTANICAL NAME	COMMON NAME
EVERGREEN TREES	
<i>Abies concolor</i>	White Fir
<i>Calocedrus decurrens</i>	Incense Cedar
<i>Cedrus atlantica</i> 'glanca'	Atlas Cedar
<i>Cedrus deodara</i>	Deodar Cedar
<i>Cedrus libani</i>	Cedar of Lebanon
<i>Chamaecyparis obtusa</i>	Hinoki falsecypress
<i>Cupressus sempervirens</i>	Italian Cypress
<i>Curpessus arizonica</i>	Arizona Cypress
<i>Juniperus osteosperma</i>	Utah Juniper
<i>Juniperus chinensis</i>	Chinese Juniper
<i>Juniperus scopulorum</i>	Rocky Mountain Juniper
<i>Juniperus virginiana</i>	Eastern Red Cedar

BOTANICAL NAME	COMMON NAME
EVERGREEN TREES	
Larix kaempferi	Japanese Larch
Metasequoia glyptostroboides	Dawn Redwood
Picea abies	Norway Spruce
Picea engelmannii	Engelmann spruce
Picea pungens glauca	White or Blackhills Spruce
Picea omorika	Serbian Spruce
Picea pungens	Blue Spruce
Pinus aristata	Bristlecone Pine - Rocky Mtn.
Pinus bungeana	Lacebark Pine
Pinus contorta var. latifolia	Lodge Pole Pine
Pinus edulis	Pinyon Pine
Pinus flexilis	Limber Pine
Pinus flexilis glauca	Vanderwolf Pine
Pinus leucodermis	Bosnian/Dwarf Pine
Pinus jeffreyi	Jeffrey Pine
Pinus monophylla	Singleleaf Pinyon Pine
Pinus monticola	Western White Pine
Pinus mugo	Mugo Pine
Pinus nigra	Austrian Pine
Pinus parviflora	Japanese White Pine
Pinus ponderosa	Ponderosa Pine
Pinus thunbergiana	Japanese Black Pine
Pinus wallichiana	Himalayan White Pine
Pseudotsuga menzeisii	Douglas Fir
Pseudotsuga menzeisii 'Glaucua'	Rocky Mountain Fir
Sequoiadendron giganteum	Giant Sequoia
Taxodium distichum	Baldcypress
Thuja occidentalis	Arborvite

BOTANICAL NAME	COMMON NAME
SHRUBS	
Abies balsamea 'Nana'	Dwarf Balsam Fir

BOTANICAL NAME	COMMON NAME
SHRUBS	
<i>Amelanchier alnifolia</i>	Saskatoon Serviceberry
<i>Amelanchier utahensis</i>	Utah Serviceberry
<i>Amorpha canescens</i>	Lead Plant
<i>Amorpha fruticosa</i>	Flase Indigo
<i>Arctostaphylos patula</i>	Greenleaf manzanita
<i>Artemisia cana</i>	Silver Sagebrush
<i>Artemisia filifolia</i>	Sand Sagebrush
<i>Artemisia frigida</i>	Fringed Sagebrush
<i>Artemisia ludoviciana</i>	Prairie Sagebrush
<i>Artemisia nova</i>	Black Sagebrush
<i>Artemisia tridentata</i>	Big Sage, Sagebrush
<i>Atriplex canescens</i>	Four winged Salt Bush
<i>Atriplex conferifolia</i>	Shade Scale
<i>Atriplex gardneri</i>	Gardner Salt Bush
<i>Berberis sp</i>	William Penn
<i>Berberis fremonti</i>	Desert Holly
<i>Buddleia davidii</i>	Butterfly bush; black beauty
<i>Caragana arborescens</i>	Siberian Peashrub
<i>Ceratoides lanata</i>	Winterfat
<i>Cercocarpus ledifolius</i>	Curl-leaf Mountain Mahogany
<i>Chaenomeles japonica</i>	Flowering quince
<i>Chamaebatiaria milliefolium</i>	Fernbush
<i>Chilopsis linearis</i>	Desert Willow
<i>Chrysothamnus nauseosus</i>	Rubber Rabbitbrush
<i>Continus coggygria</i>	Smoke Tree or Smokebush
<i>Cornus sp.</i>	Red Twig Dogwood, Yellow Twig Dogwood, Tartarian Dogwood
<i>Cornus sericea 'Kelseyi'</i>	Dwarf Kelsey Dogwood
<i>Cowania mexicana</i>	Cliff Rose
<i>Cytisus scoparius</i>	Broom: moonlight, Burkwood, Hollandia, Lena, Lilac Time
<i>Daphne burkwoodii</i>	Daphne

BOTANICAL NAME	COMMON NAME
SHRUBS	
<i>Ephedra viridis</i>	Mormon Tea or Brigham Tea
<i>Euonymus alatus compacta</i>	Dwarf Winged Euonymus
<i>Fallugia paradoxa</i>	Apache Plume
<i>Forestiera neomexicana</i>	New Mexico Privet or Desert Olive
<i>Forysthia sp</i>	Dwarf Forsythia
<i>Forsythia courtasol</i>	Dwarf Gold tide
<i>Grayia Spinosa</i>	Snakebrush/Hop Sage
<i>Hesperaloe paruiiflora</i>	Red Yucca, Duct Red Yucca
<i>Hibiscus syriacus</i>	Rose of Sharon
<i>Hippophae rhamnoides</i>	Sea buckthorn
<i>Ilex sp.</i>	Holly
<i>Ilex meservea</i>	Holly Blue boy
<i>Ilex verticillata</i>	Winterberry holly
<i>Juniperus chinensis</i>	Phitzer Juniper, Blue Point Juniper and other upright varieties
<i>Juniperus horizontalis</i>	Creeping Juniper
<i>Juniperus Sabina</i>	Juniper
<i>Kerria japonica</i>	Japanese Kerra
<i>Kolkwitzia amabilis</i>	Beauty Bush
<i>Ligustrum vulgare</i>	Common Privet (several varieties of screening)
<i>Lonicera japonica</i>	Honeysuckle; Hilliana
<i>Mahonia aquifolium</i>	Oregon Grape
<i>Mahonia repens</i>	Dwarf oregon grape
<i>Peraphyllum ramosissimum</i>	Squaw Apple
<i>Peraphyllum caespitosum</i>	Rock Spirea, Tufted Rock Mat
<i>Perovskia</i>	Russian sage
<i>Philadelphus sp.</i>	Mockorange, Sweet Mockorange (dwarf varieties also available)
<i>Philadephus microphyllus</i>	Littleleaf Mockorange
<i>Physocarpus malvaceus</i>	Mountain Ninebark
<i>Physocarpus opulifolius</i>	Ninebark; Darts gold, Diabolo, Dwarf

BOTANICAL NAME	COMMON NAME
SHRUBS	
<i>Pinus mugo</i> cultivars	Dwarf Mugo Pine
<i>Potentilla fruticosa</i>	Shrubby Cinquefoil, 'Fronsty' or 'Hinrob', Marion Red Robin
<i>Prunus besseyi</i>	Western Sand Cherry
<i>Prunus x cistena</i>	Purple Sand Cherry
<i>Purshia mexicana</i> var. <i>stansburiana</i>	Cliff Rose
<i>Purshia tridentata</i>	Antelope Bitterbrush
<i>Pyracantha angustifolia</i>	Dwarf Pyracantha
<i>Rhamnus asplenifolia</i>	Fernleaf Buckthorn
<i>Rhamnus columnaris</i>	Upright Buckthorn
<i>Rhamnus smithii</i>	Smith's buckthorn
<i>Rhus aromatica</i> 'Grow Low'	Fragrant sumac
<i>Rhus glabra</i>	Smooth Sumac
<i>Rhus glabra cismontanta</i>	Dwarf Mountain Sumac
<i>Rhus glabra laciniata</i>	Cutleaf Smooth Sumac
<i>Rhus trilobata</i>	Oak.three leaf
<i>Rhus typhina laciniata</i>	tiger eye gold leaved
<i>Ribes</i> sp.	Alpine Currant, Golden Currant
<i>Rosa meidiland</i>	Meidiland Rose
<i>Salix purpurea nana</i>	Dwarf Blue Arctic Willow
<i>Salvia dorrii</i>	Dorr's Sage
<i>Sambucus</i> sp	Elderberry, black beauty,
<i>Shepherdia argentea</i>	Silver Buffaloberry
<i>Spiraea x bumalda</i>	Spriea; Anthony waterer
<i>Spiraea x vanhouttei</i>	Bridal Wreath Spiraea
<i>Symphoricarpos</i> sp	Coralberry/Snowberry
<i>Symphoricarpos orbiculatus</i>	Coralberry/Snowberry Indian current
<i>Symphoricarpos oreophilus</i>	Mountain Snowberry
<i>Syringa meyeri</i> 'Palibin'	Dwarf Korean Lilac
<i>Syringa patula</i> 'Miss Kim'	Miss Kim Lilac
<i>Taxus cuspidata</i>	Japanese Yew

BOTANICAL NAME	COMMON NAME
SHRUBS	
Taxus sp. (low spreading)	Spreading English Yew, Upright Yew, Browns, Yew and Others
Thuja occidentalis	Eastern White Cedar
Viburnum burkwoodii	Burkwood Viburnum
Weigela florida	Weigela
Yucca filamentosa	Yucca; garland gold, ivory tower, colorguard

BOTANICAL NAME	COMMON NAME
GROUND COVER	
Ajuga	Bugleweed
Arabis caucasica	Rock Cress
Cerastium tomentosum	Snow In Summer
Delosperma cooperi	Delosperma, Ice Plant
Delosperma nubigenum	Yellow Ice Plant
Euonymus fortunei	Winter Creeper
Fargesia	Pink Panda' and 2 others
Genista pilosa	Vancouver Gold'
Hedera helix	English Ivy
Helianthemum nummularium	Sunrose, Rockrose
Hypericum calycinum	Aaron's Beard, St. John's Wort
Lamium maculatum	Spotted deadnettle
Pachistima canbyi	Dwart Moutian Lover
Sedum sp.	Stonecrop
Thymus cultivars	Thyme; wooly
Veronica	Creeping Veronica
Vinca major and minor	Periwinkle

BOTANICAL NAME	COMMON NAME
VINES	
Campsis radicans	Trumpet Vine
Clematis 'Hybrids'	Clematis
Clematis ligusticifolia	White Virgin's Bower

BOTANICAL NAME	COMMON NAME
VINES	
Hedera helix	English Ivy
Hydrangea anomala subsp. petiolaris	Climbing Hydrangea
Polygonum aubertii	Silverlace Vine

BOTANICAL NAME	COMMON NAME
ORNAMENTAL GRASSES (USE AS ACCENT OR IN MASSES)	
Achnatherum calamagrostis	Spear Grass
Aristata purpurea	
Bouteloa gracilis	Blue Grama
Calmagrostis acutiflora 'Karl Foerster'	Feather Reed Grass
Calmagrostis brachytricha	Korean Feather Reed Grass
Carex sp	
Cespitosa 'Goldschleier'	Gold Vieled Tufted Hair Grass
Chasmanthium latifolium	Indian Woodoats
Cortaderia selloana	Pampas Grass
Deschampsia sp.	Tufted Hair Grass
Festuca sp.	Coyota
Hakonechloa macra	Japanese forest grass
Helictotrichon sempervirens	Blue Oat Grass
Miscanthus "Adagio"	Idaho fescue
Miscanthus "Purpurascens"	Flame grass
Miscanthus Sinesis	"Little Gem"
Miscanthus s. 'Gracillimus'	Maiden grass
Miscanthus s. 'Graziella'	Silver Grass
Miscanthus s. 'Morning Light'	Morning Light Japanese silver grass
Miscanthus s. 'Puenktchen'	Little Dot'
Miscanthus s. 'Variegatus"	Variegated Japanese Silver (Eulalia) Grass
Miscanthus s. 'Zebrinus'	Zebra Grass
Panicum virgatum	"Shenandoah"
Pennisetum oriental	Fountain Grass
Pennisetum ruppelii	Oriental Fountain Grass
Phalaris arundicacea	Feesey's Form

BOTANICAL NAME	COMMON NAME
ORNAMENTAL GRASSES (USE AS ACCENT OR IN MASSES)	
Saccharum ravennae	Ribbon Grass
Schizachyrium scoparium	Formerly: Erianthus ravennae ; Ravenna Grass
Sesleria autumnalis	Little blue stem
Sorghastrum nutans	Autumn Moor Grass
Sporobolus airoides	"Cheyenne"
Stipa gigantea	Giant Feather Grass

BOTANICAL NAME	COMMON NAME
HERBACEOUS PERENNIALS	
Agastache ssp.	Hyssop, Hummingbird Mint
Alcea rosea	Hollyhock
Alchemilla	Ladys Mantle
Alyssum saxatilis compactum	Basket of Gold
Anacyclus depressus	Mount Atlas Daisy
Anemone hupehensis	Japanese Anemone
Anemone hybrids	Anemone
Anemone pulsatilla	Pasque Flower
Antennaria dioica	Pussy Toes
Aquilegia sp.	Columbine
Arabis caucasica	Rock Cress
Arenaria ssp.	Sandwort
Armeria maritima	Common Thrift or Sea Pink
Artemisia frigida	Fringed Sage
Artemisia ludoviciana	Prairie Sagebrush
Artemisia schmidtiana	Silver Mound
Artemisia versicolor 'Seafoam'	Curlicue Sage
Asclepias tuberosa	Butterfly Milkweed
Astilbe sp.	Astilbe
Aubretia	Rock Cress
Baptisia	False Indigo
Brunnera sp.	Brunnera

BOTANICAL NAME	COMMON NAME
HERBACEOUS PERENNIALS	
Bulbs	Spring Flowering Bulbs
Callirhoe involucrata	Poppy Mallow
Calylophus spp.	Sundrops
Campanula sp.	Bellflower
Catananche sp.	Cupid's Dart
Chrysanthemum x superbum	Shasta Daisy
Coreopsis verticillata	Tickseed, moombean
Dephinium nattalianum	Perennial Larkspur
Dianthus sp	Dianthus Pinks
Diascia integerrima 'Coral Canyon'	Twinspur
Dicentra eximia	Fringed Bleeding Heart
Dicentra formosa	Pacific Bleeding Heart
Dicentra spectabilis	Bleeding Heart
Digitalis obscura	Dusty Foxglove, Willow Leaf Foxglove
Digitalis thapsi 'Spanish Peaks'	Spanish Peaks Foxglove
Echinacea purpurea	Purple Coneflower
Echinops sp.	Thistle
Epilobium angustifolium	Fireweed
Eriogonum umbellatum	Sulphur Flower
Eriophyllum lanatum	Woolyleaf, Oregon Shunshine
Eryngium alpinum	Blue Sea Holly
Eryngium sp.	Sea Holly
Gaillardia sp	Blanketflower
Gaura coccinea	Scarlot Guara
Geranium sp.	Cranebill
Gilia aggregata	Scarlet Gilia
Guara lindheimeri	"Siskyu Pink' Gaura
Gutierrezia sarothrae	Snakeweed
Hemerocallis hybrid	Daylily
Helianthella uniflora	Little Sunflower
Helianthemum nummularium	Sun Rose
Helleborus foetidus	bear's-paw hellebore

BOTANICAL NAME	COMMON NAME
HERBACEOUS PERENNIALS	
Heuchera sp.	Coral Bells
Hibiscus coccineus	Scarlet Hibiscus
Hosta sp.	Hosta
Houttuynia cordata	Chameleon plant
Hypericum calycinum	St. Johnswort
Iberis sempervirens	Candytuft
Iliamna rivularis	Mountain Hollyhock
Iris Hybrids	Iris
Kniphofia uvaria	Red Hot Poker
Lavandula angustifolia	Lavender
Limonium latifolium	Statice, Sea Lavender
Linum sp.	Golden Flax, Perennial Flax, Native Blue Flax
Lychnis coronaria	Rose campion
Mirabilis multiflora	Showy Four-O-Clock
Monarda didyma	Bee Balm - Cultivars supposedly mildew resistant: 'Jacob Cline', 'Dark Ponticum', 'Marshalls Delight'. 'Raspberry Wine'. 'Colrain Red'.
Narcissus species	Daffodil
Nepeta x Faassenii	Catmint
Oenothera sp.	Evening Primrose
Oenothera caespitosa	Evening Primrose
Papaver orientale	Oriental Poppy
Papaver sp.	Poppy, Oriental Poppy
Penstemon sp.	Firecracker Penstemon, Palmer Penstemon, Shrublet Penstemon, Wasatch Penstemon
Penstemon palmeri	Balloon Flower
Penstemon pinifolius	Pine leaf Penstemon
Perovskia atriplicifolia	Russian Sage
Phlox hoodii	Carpet Phlox
Phlox longifolia	Long leaved Phlox
Phlox subutata	Creeping Phlox
Physostegia sp.	Obedient plant

BOTANICAL NAME	COMMON NAME
HERBACEOUS PERENNIALS	
Polemonium	Jacob's ladder
Pulmonaria langifolia	
Ratibida columnaris	Prairie Coneflower, Mexican Hat
Rudbeckia sp.	Black Eyed Susan, Dwarf Rustic Coneflower
Salvia sp.	Salvia
Santolina sp.	Lavender Cotton
Saponaria ocymoides	Rock Soap Wort
Sedum sp.	
Solidago sp.	
Stanleya sp.	
Tradescantia sp.	
Tulipa hybrids	Tulip
Verbena sp.	
Zauschneria californica	Orange Carpet; catalina
Zauschneria latifolia	Orange Carpet; Garrettii
Zinnia grandiflora	Rocky Mtn. Zinnia

BOTANICAL NAME	COMMON NAME
CACTI	
Coryphantha vivipara	Nuttal's Pincushion
Echinocereus engelmannii	Hedge Hog Cactus
Echinocereus triglochidiatus	Claret Cup
Opuntia ssp.	Common Pricklypear
Pediocactus simpsonii	Simpson's Footcactus

BOTANICAL NAME	COMMON NAME
TURF GRASS	
Xerilawn	
Bella Blue	
BioMeadow	
RTF – <i>preferred in areas that will have minimum foot traffic – substitute for bluegrass</i>	
Blue Grass – <i>high traffic areas</i>	

Note: Do not plant turf in areas between hard surfaces less than 8-ft wide. Decorative rocks and boulders are preferred in landscaping where feasible.

- (5) Topsoil Guidelines
 - a. Topsoil for General Applications
 - i. Provide a minimum of 12-in of topsoil in all planting beds and a minimum of 6-in of topsoil in all lawn areas.
 - ii. Subsoil will not be accepted as topsoil.
 - iii. Soils with less than 4-percent organic matter shall be amended.
 - b. Soil Preparation and Amendments
 - i. When contract operations have been completed to a point where the areas will not be disturbed, the Contractor shall clean the subgrade so as to be free of waste material of all kinds.
 - ii. Direct the Contractor to scarify and pulverize the subgrade to a depth of 6 inches, then mix layered soils as follows:
 - (a) First distribute a 2 to 3-in layer of the new soil.
 - (b) Mix the new soil thoroughly with the existing soil.
 - (c) Distribute the remainder of the new soil on top.
 - iii. Scarification shall be completed in all areas that are to receive plant materials.
 - iv. Animal fertilizer is not to be used on Campus.
 - v. Specify chemical fertilizer to be 16-16-8 with guaranteed analysis marked on the container.
- (6) Compost
 - a. Compost materials include: composted weed residues, peat, leaf, and mushroom mulch. Require the Contractor to coordinate with the University Project Manager and A/E prior to using compost at the site to determine the appropriate compost for the intended area.
- (7) Mulch
 - a. Specify this material to be medium coarseness. All planting beds shall receive a 4-in mulch layer.
- (8) Sod
 - a. The University will not allow hydro-seeding nor any manual seeding. Seeding will not be used in place of sod.
 - b. Sod Specifications
 - i. All sod shall be 18 month old Kentucky Blue Grass that has been cut fresh the morning of installation. Only specify sod that has been grown on a commercial sod farm. Do not allow sod from any other source.
 - ii. Apply fertilizer prior to laying any sod.
 - iii. Specify that all sod that has not been laid within 24 hours shall be deemed unacceptable and will be removed from the site.
 - iv. Direct the Contractor to lay sod with seams tightly closed with no gaps between each piece of sod.
 - v. Instruct the Contractor to apply water directly after laying sod. Rainfall is not acceptable.

- vi. Require the Contractor to rope off and secure new grass areas until the sod is established or grown sufficiently to the first mowing.
- c. Fertilizer for Sod Applications
 - i. Commercial fertilizer shall be specified as a mixed commercial fertilizer, O-F-241C, type 1, grade 16-16-8, level B with guaranteed chemical analysis of contents marked on the containers.
- d. Topsoil Specifications for Sod
 - i. Specified topsoil shall consist of natural sandy loam and be of uniform quality, free from subsoil, hard clods, stiff clay, hard-pan, sod, partially disintegrated debris, or any other undesirable material. Soil shall be free of plants, roots, or seeds that would be toxic or harmful to growth. Topsoil shall be obtained from naturally drained areas and shall contain at least 4-percent organic material as determined by loss upon ignition of a moisture free sample that has been dried in accordance with current methods of the Association of Official Agricultural Chemists. pH range shall be 5.5 to 8.2 inclusive.
 - ii. Require the Contractor to furnish a certified report of an analytical chemist approved by the A/E showing the analysis of the topsoil proposed for use. Further require the Contractor to furnish a sample of the proposed topsoil to the A/E prior to delivery of topsoil on site.
- e. Top Soil Installation for Sod
 - i. When contract operations have been completed to a point where the areas will not be disturbed, the Contractor is to clean the subgrade so as to be free of waste material of all kinds. Direct the Contractor to scarify and pulverize the subgrade to a depth of not less than 4 inches. Scarification shall be completed in all areas that are to receive plant materials whether it is to be sod, trees, ground cover, or shrubs.
 - ii. Specify the distribution of topsoil to a depth of 6-in in all planting areas shown in the Contract Documents. Do not allow the placement of topsoil over subgrade that is frozen or damp.
 - iii. The surface on which the sod is to be laid is to be specified firm and free from footprints, depressions, or undulations of any kind. Specify the surface to be free of all materials larger than 1/2-in indiameter.
 - iv. The finish grade of the topsoil adjacent to all sidewalks, mow strips, etc., prior to the laying of the sod, shall be set such that the crown of the grass shall be at the same level as the adjacent concrete or hard surface.
- f. Sod Installation
 - i. Include the following inspecifications:
 - (a) Prior to laying of sod, the entire surface to receive sod shall be uniformly covered with the specified fertilizer at the rate of 4-lbs per 1,000 square feet. Notify the University Landscape Maintenance Department 24-hours prior to intended fertilizer application. The A/E, University Project Manager and University Landscape Maintenance may inspect the site and fertilizer prior to application, and witness the application procedure.
 - (b) Upon completion of the laying operation, an inspection of the area shall be made. All voids and large cracks between individual pieces of sod shall be filled with topsoil, prior to watering.

- (c) Watering of the sod shall be the complete responsibility of the Contractor by whatever means necessary to establish the sod in an acceptable manner prior to acceptance by the University. If an irrigation system is in place on the site, but for whatever reason, water is not available in the system, it is the full responsibility of the Contractor to water the sod by whatever means, until the sod is accepted by the A/E and University Landscape Maintenance Department.
 - (d) Upon completion of filling all voids in the newly laid sod areas, the sod is to be completely saturated with water.
 - (e) Protection of the newly laid sod shall be the complete responsibility of the Contractor. Instruct the Contractor to provide acceptable visual barriers, to include barricades set at appropriate distances with strings or tapes between the barriers, as an indication of new work. Specify that the Contractor is to restore any damaged areas caused by others (including vehicular traffic), erosion, etc., until such time as the lawn is accepted by the University.
- g. Sod Guarantee
- i. Specify that the Contractor shall be responsible for the protection, watering, and replacement of any damaged sod until acceptance by the University. This guarantee shall include filling any voids between sod pieces, repairing of any eroded areas, and maintaining the sod by watering, mowing, and controlling of insects, as well as advising the University of any maintenance or watering procedures necessary to care for and promote plant life. All sod shall be in satisfactory condition at the time of the substantial completion inspection.
- B. University Campus Tree Standards
- (1) Value of Campus Trees
- a. The University of Utah campus is Utah's State Arboretum. Each tree on campus has a significant value to the University, each is cataloged, and the condition of each tree is monitored.
 - b. The current monetary value for each tree will be established by the Landscape Maintenance Department for each project where trees may be affected by construction.
 - i. A/E drawings and specifications shall include the dollar value of each tree which is intended to remain on, and/or adjacent to the project site.
 - ii. The cost shown for each tree will establish the basis for the Contractor's liability if any tree is damaged due to construction activities or the Contractor's lack of care.
- (2) Tree Replacement on Campus
- a. Include the following statement in the Construction Documents:
 - i. "Written permission by the Landscape Maintenance Department (through the A/E and University Project Manager) is required prior to the removal of any tree on campus."
 - b. When a project includes the planned removal of trees, or when trees are removed by the Contractor for any reason, either the project or the party responsible for the removal shall replace each lost tree with at least two new trees.

- i. The Landscape Maintenance Department reserves the right to require replacement by more than two-for-one, or by a larger caliper specimen size, when tree removal will cause significant loss of value to the University (i.e., prominent landmark, tree function / value to the site, historical value, pairing loss to other trees, significant loss to the State Arboretum, etc.).
 - ii. The Landscape Maintenance Department will consider A/E suggestions for the species proposed for the replacement; however, the Landscape Maintenance Department is the jurisdiction having authority and will make the final determination of the selection of the tree species, and determine exact location(s) for replacement tree plantings.
 - iii. When trees are planned to be removed for new construction, the A/E's drawings / specifications shall identify the species and location of replacement trees as directed by the Landscape Maintenance Department.
- (3) Tree Damage During Construction
 - a. The A/E shall observe the status of the trees during regular inspection site visits. Tree damage at the project site, including overstressed, dying or dead trees, shall be reported to the Contractor and University Project Manager as soon as it is observed. Photograph the damage. The University Project Manager will coordinate with the Landscape Maintenance Department to determine the cause of the damage, assess the value of loss based on the tree's cost shown in the project documents, and direct any remedial action required to restore the tree.
 - b. The A/E shall include damage penalties in the specifications if trees are to be saved on site. Base the penalties on the value of each tree as determined by the University Landscape Maintenance Department.
 - c. For trees which are damaged beyond recovery due to Construction or lack of care, the Contractor shall be responsible for replacement in accordance with [4.3 B \(2\)](#).
- (4) Tree Protection at University Construction Sites
 - a. In the drawings and specifications, the A/E shall establish the Contractor's responsibility to care for and protect each tree which will remain on site, or face penalties for damage, or replace each lost tree in accordance with the terms established by the Landscape Maintenance Department.
 - b. General Requirements for Tree Protection
 - i. Trees can be damaged or killed by a wide variety of construction activities. Above ground injuries such as broken branches or torn bark are open wounds which can deplete a tree's energy resources and provide entry points for insects or diseases.
 - ii. Root damage can be a significant danger to a tree. Critical roots generally exist in the top one to three feet of soil extending out to the drip line of the tree canopy, and beyond to a distance of two times the height of the tree.
 - c. Protected Root Zone (TPZ – Tree Protection Zone)
 - i. Determine the area needed for the tree protection zone ("TPZ") for each tree, including trees which could be affected adjacent to the construction site. The TPZ is the approximate distance from the tree trunk in which a critical amount of the tree's roots may be found. This is the area which should be isolated from construction activity, and is determined as follows:
 - (a) Estimate the height of the tree.

- (b) Multiply the tree height by 0.40.
- (c) Measure and mark this distance from the tree trunk. If this distance is less than the extent of the tree's canopy drip line, extend the mark to the outside drip line.
- ii. Specify that nothing inside the TPZ is to be raked, cut, stored, or otherwise disturbed.
- iii. Specify regular watering during construction.
- d. TPZ Fence
 - i. Direct the Contractor to install protective fencing around each tree at the marked TPZ perimeter. Specified fencing shall be sturdy and highly visible to discourage entrance and disturbance of the area within the TPZ.
 - ii. Specify either chain-link, or sturdy wire mesh, or wood fencing. Require the Contractor to solidly anchor the fencing into the ground.
 - iii. Require the Contractor to attach weather protected warning signs every 50 linear feet along the fence (for a smaller TPZ, require a minimum of two signs at appropriate locations on the perimeter fence). Each sign shall be at least two feet wide, with red lettering on white background, with the following message prominently displayed:

TREE PROTECTION AREA

 DO NOT ENTER

 ZONA DE PROTECCION
 PARA ARBOLES – NO ENTRE

- iv. Specify fencing height of 4 to 6 feet or higher depending on the needs of the site and anticipated construction activities.
- v. If the A/E's design cannot guarantee that construction traffic will remain outside of a tree's TPZ for the entire duration of construction, require trunk protection as described herein, and additionally specify one or more of the root protection measures described below.
- e. Trunk Protection
 - i. Instruct the Contractor to install a closed cell foam pad around the trunk and buttress roots, overlaid with 2-inch thick wood planks (2-in x 4-in or 2-in x 6-in as appropriate) arranged vertically and approximately 1-in apart.
 - ii. Specify straps or wire to bind the planks in place.
 - iii. Do not allow the Contractor to drive fasteners into the tree.
 - iv. As determined by the length of the construction schedule, require the Contractor to adjust the strap or wire binding during periods of trunk diameter growth.
- f. Root Protection Measures
 - i. Options available to the A/E for root protection measures within the TPZ are:
 - (a) 6 to 12-in of wood chip mulch evenly distributed within the protection zone.
 - (b) A 3/4-in plywood deck, or a matt of 4 x 4 wood beams laid over 4+ inches of wood chip mulch evenly distributed within the protection zone.
 - (c) 4 to 6-in of gravel laid evenly over a taut, staked geotextile fabric.

- (d) Commercial logging or road mats assembled over support rails, laid over a 4-in to 6-in mulch layer.
 - ii. Root protection measures specified by the A/E shall be inspected daily by the Contractor and refreshed as conditions warrant (i.e., weather, time, traffic wear, etc.).
 - iii. Trunk and vehicle load protective methods described above shall be removed from the TPZ when the threat of damage has ended, or at Substantial Completion, whichever occurs first.
 - iv. The TPZ perimeter fence shall remain in place until immediately before the required construction activity within the TPZ.
 - v. The TPZ perimeter fence shall be replaced as soon as possible when the required construction activity in the TPZ is done.
- (5) Tree Planting Procedure
- a. The tree planting hole should be the same depth as the root ball, and three times the diameter of the root ball.
 - b. Trees shall be placed on undisturbed soil at the bottom of the planting hole.
 - c. The tree hole depth shall be determined so that the tree may be set slightly high of finish grade, 1-in to 2-in above the base of the trunk flare, using the top of the root ball as a guide.
 - d. Except in rare cases trees should not be staked.
 - e. Set tree on soil and remove ALL burlap, wire baskets, twine, wrappings, etc. before beginning any backfilling operations.
 - f. All tree holes shall be backfilled in 12 inch lifts and settled with water to minimize any settling of the tree.
 - g. Upon completion of backfilling operation, thoroughly water the tree to completely settle the soil and fill any voids that may have occurred. Use a watering hose, not the area irrigation system. If additional prepared topsoil mixture needs to be added, it should be a coarser mix as required to establish finish grade.
 - h. The amount of pruning shall be limited to the minimum necessary to remove dead or injured twigs and branches. All cuts, scars and bruises shall be properly treated according to the direction of the A/E. Proper pruning techniques shall be used. Do not leave stubs and do not cut the leader branch. Improper pruning shall be cause for rejection of the plant material.
 - i. Prepare a watering circle of 2' diameter around the trunk. For conifers, extend the watering well to the drip line of the tree canopy. Place 4-in of mulch around the planted trees.
 - j. Tree wrap is not used on campus.
 - k. Upon completion of all planting operations, The Contractor is to remove all undesirable material from the surface of the planting beds, including all rocks over the size of 1/2-inch diameter; re-establish all watering basins and install the specified mulch.
- (6) Tree Grates
- a. Tree grates should be specified for trees located in paved walkways so the inner rings can be cut as the tree grows. They should be removable grates for maintenance

purposes equal to D & L Supply Co. #R-8740 180-degree square with cast iron angle frame.

C. Roof Top Gardens

- (1) Irrigation system is required to be a two wire system controller with WiFi Module.
- (2) Soil moisture sensor is required for each planter bed.
- (3) Designer should structure zones based on light, reflection, plant type, and plant layout.
- (4) In line drip emitters need to be installed at 12-in spacing in a grid pattern using 0.6-in gph emitters.
- (5) Hydrometers should include infrared registers.
- (6) Where rooftop access is not protected by a guard as prescribed in the IBC; and maintenance or work of any kind is performed within 10 feet of roof edges or open sides of walking surfaces, guards or approved safety harness systems shall be installed.
- (7) All valves shall be freely accessible for maintenance from the roof, and be protected from the elements.
- (8) A hose bib shall be included at every manifold off of the mainline, an isolation valve shall be included in line preceding the hose bib.
- (9) Mainline isolation needs to be included inside of the building with easy access for the landscape maintenance department. It shall not be placed in areas that require safety certification and protection in order to access. Keys should be provided to the landscape department for any areas required to be locked.
- (10) Where rooftop access is not required by the IBC or IFC, and rooftop gardens are installed, access to the rooftop garden shall be provided by means of permanent ladders or stair systems.
- (11) A ¼-inch test cock is to be included for a pressure gauge test for irrigation to be on the same floor as the rooftop landscape. The test cock is to be installed near the point of change from Copper to PVC. Pressure should be designed to be 90 PSI at the test port.

D. Site Furniture

- (1) Anchors for Site Furniture
 - a. Specify all site furniture with appropriate anchors to the concrete slab on which they are mounted, per manufacturer's instructions.
- (2) Exterior Benches and Tables
 - a. Specify benches (backed or backless) and tables with coated metal grid assemblies with secure ground attachments.
 - b. Colors are to be selected and approved by Facilities Management.

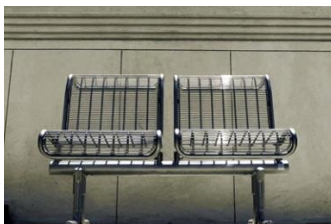



- c. Approved manufacturer is Landscape Forms, Inc. "Plexus" benches, "Carousel" tables.
- (3) Bike Racks
- a. Campus Planning will determine whether the proposed bicycle parking is located in an area of campus with higher or lower density parking demands.
 - b. The "inverted "U" bicycle rack with the galvanized finish is the campus standard for areas of campus with lower density bicycle parking demand.
 - i. For bike racks specified as an inverted "U" rack with no cross bar. The inverted "U" rack shall be fabricated from 2-in Schedule 40 galvanized tubing. The overall vertical dimension shall be 40-in. The overall width of the rack measured leg to leg shall be 22-in, measured from outside vertical tube to outside vertical tube.
 - ii. The installed rack shall have a vertical dimension of 34-in from top of concrete to top of the inverted "U". Each leg's remaining 6-in shall be cored into concrete with a 3-in diameter core, and filled after the rack is set with expansive anchoring cement, non-shrink grout.
 - iii. The completed installation shall be true and plumb, square to building lines. Each core drilled hole shall be no closer than 3-in to any concrete edge or expansion joint or line. When installing a series of racks, consideration shall be taken not to place them too close to each other, a minimum of 30-in shall be maintained between racks.
 - iv. If a series of inverted "U" bike racks is specified, require the Contractor set the racks such that the clear space between individual racks is a minimum of 30-in.
 - c. The stainless steel inverted "U" rack is recommended for high profile areas of campus with lower density demand, i.e. campus portals.
 - d. For high density bicycle parking demand areas, a rack meeting the following specifications is required:
 - i. the rack contains the front wheel, preventing bicycles from falling over;
 - ii. the rack itself is located on one side of the parking area, leaving more area clear when the racks are not in use than the "inverted U" rack;
 - iii. allows two point locking for security;
 - iv. the racks can be placed closely together and angled, allowing higher density layouts,
 - v. the finish is either galvanized or stainless steel.

- e. If desired, a brightly colored "artsy" bicycle rack, approved by Campus Planning, may be placed in a highly visible position to draw attention to the high density rack bicycle parking area.
- (4) Waste Receptacles
- a. Waste receptacles shall be located at each main entry to the building (next to the entry door but out of the way for snow removal) and on each patio. Design a concrete pad extension to the entry or patio specifically for trash receptacles and urns to avoid snow plows. Direct the Contractor to bolt waste receptacles and urns to the concrete pad. The waste receptacles shall be cast concrete units manufactured by WAUSAU TILE CO., Number TF 1040. Round receptacles will not be approved. Color shall be Sand. Waste receptacles shall also be equipped with a No. TF 2094 Snuffer Attachment.
 - b. Where exterior site furniture weight is a limiting criterion, and design approval is received for Plexus / Landscape Forms benches, specify waste receptacles (side opening with sand pan) from the same manufacturer, with coated metal grid assemblies
- (5) Urns
- a. Wall mount urns shall be cast concrete matching the trash receptacles in item 3 above. Specify WAUSAU TILE COMPANY Number UR 10201NS or UR11201NSPL, sand color. Selection of the specific unit style will be made by the University Project Manager and Landscape Maintenance Department. Provide a special concrete pad to avoid snow plows.
- E. Grounds Storage Closet
- (1) Each new building and each remodel, where applicable, is to include a storage closet for University Landscape Maintenance Department equipment and supplies, accessible from the exterior. Coordinate with the University Project Manager who will contact the Landscape Maintenance Department for specific design criteria. Generally, each storage closet should be at least 6' x 6' and 7' high (unobstructed), with general lighting, electrical outlets, and sufficient heat to prevent freezing.
- F. Chain Link Fences and Gates
- (1) Indicate acceptable materials and products which may be used in construction of this project. Determine manufacturers and consult with Facilities Management through the University Project Manager.
 - (2) No fencing shall be attached to any building or gate anchor to any building without approval of Facilities Management.
 - (3) Fencing Product/Materials
 - a. Fabric:
 - i. PVC coated steel chain link fabric with zinc coating applied to core wire. Material to be helically wound and interwoven in such a manner as to provide a continuous mesh without knots or ties except in the form of knuckling at both ends of the wires to form the selvage of the fabric.
 - ii. Fabric mesh size shall be 2-in x 2-in except in areas where children climbing on fences is to be discouraged. In such areas, the mesh size shall be 1-in x 1-in.
 - iii. Fabric breaking strength shall be 800-lbs per square foot.
 - iv. Fabric height to be as noted on drawings.

- v. Weight of zinc coating on fabric shall be 0.30 oz. per square foot.
- vi. Fabric selvage to be knuckled at both ends.
- vii. Thickness of PVC coating on fabric shall be 0.015 inches min.
- viii. Fabric color to be black.
- b. Pipe shall be zinc coated with a chromate conversion applied. Polyester resin color coating thermally fused to the zinc coated pipe.
 - i. End structural post shall be 2-1/2" o.d. diameter pipe with a wall thickness of 0.130 inches.
 - ii. Line posts shall be 2" o.d. diameter pipe with a wall thickness of 0.120 inches.
 - iii. Zinc coating shall be a min. of 0.06 oz. per square foot.
 - iv. Color coating shall be 0.004 inches thick and over cured.
 - v. Color to be coordinated with Facilities Management through the University Project Manager.
- c. Fittings. All fittings (bands, caps, eye tops, rail ends, sleeves, truss rods, bars, hinges, ells, clamps, scrolls, and clips) shall have an electrostatically applied polyester color resin that has been oven cured and thickness of 0.004 inches.
- d. Ties and Tension Wires. These items shall be of extruded PVC over zinc coated steel wire. Color to be coordinated with Facilities Management through the University Project Manager.
- e. Concrete footings and concrete mow strip shall be as per drawings and specifications for cast-in-place concrete.
- f. All gate material shall be consistent with the fencing material.
- g. Provide sufficient information to ensure quality workmanship. Indicate that experience is required and specify the qualifications of workmen and tolerances expected.

4.4 Irrigation Design Standards

A. Irrigation Plan

(1) General

- a. The landscape irrigation system will be specified and graphically represented on drawings using sprinklers, valves, piping, fittings, controllers, wiring, etc., of quality and capacity described herein.
- b. Once approved by the University, locations of sprinkler heads, valves, piping, wiring, etc., will be changed only with the permission of the Landscape Maintenance Department.
- c. The University expects an irrigation design which will result in a complete water distribution system efficient in operation, fully automated, low maintenance, and fully compatible with current industry standards, the University's maintenance plan, and the existing irrigation system structure.

(2) Piping

- a. Specify piping (except flex swing pipe) to be Schedule 40 pressure rated PVC with the ratings printed on the pipe, for sizes 1-in through 3-in. Specify piping to be Class 200 for sizes 4-in through 10-in, pipe ratings shall be clearly printed on the pipe. The pipe shall be new, free from cracks, holes, foreign material, blisters, inside bubbles,

wrinkles, dents, and weathering from storage outside more than three months. No pipe will be less than 1-in diameter.

- b. Main Line Piping
 - i. Main lines are to be sized appropriately to handle the gallons per minute (gpm) required to serve the three largest lateral systems.
 - ii. Main lines are to be specified with solvent welded joints (gasketed pipe will be considered on a case-by-case basis, and allowed only with permission of the University Landscape Maintenance Department). Specify primer and cement (glue) for the appropriate pipe type, applied per manufacturer's specifications. Products are to be applied per manufacturer's specifications. All connections on main lines shall be allowed to set for twenty-four hours prior to pressurization.
 - iii. Main line pipe shall be tested for a minimum of 2 hours, at a pressure of 150-psi. System shall be closed during test. Increase in pressure for testing shall be achieved by a powered pressure pump used for this specific purpose. Loss during testing shall not exceed 5%.
 - iv. Thrust Block
 - (a) The drawings and specifications shall require main lines to have a thrust block of poured concrete installed at each change of direction. The thrust block shall be of sufficient size for the pipe involved and rest on undisturbed ground. Thrust blocks shall be installed per Details LS-1, LS-2, and LS-3, Direct Bearing Thrust Blocks. No temporary thrust blocking shall be allowed.
- c. Lateral Line Piping
 - i. Lateral lines shall be specified as solvent weld with threaded connections at swing joints. Solvent welded lateral lines shall have the same specifications described for main lines. Threaded connections shall be sealed with Teflon type tape, and/or thread sealant, Rector Seal Number Five, or approved equal. Minimum pipe size shall be 1-in, no ¾-in pipe shall be allowed. Lateral pipes shall be 1-in, 1-¼-in, 1-1/2-in, 2-in, to a maximum of 2-1/2-in. Control valves and other components shall be designed to accommodate the lateral size.
- d. Flex Swing Pipe
 - i. Flex swing pipe shall be specified to be thick-walled polyethylene pipe, kink resistant, rated to at least 80 psi, and with a minimum of a two-year warranty. Approved manufacturers and models include: Rain Bird: SPX FLEX, Toro 'Super Funny Pipe', Irritrol 'Super Blue Flex'. This pipe is to be used only between heads and lateral lines and will not exceed lengths of 2-feet. Specify for use only on heads with ¾-in or smaller inlets, and sprinkler output of 6-gpm and less. Not for use with sprinklers having output over 6-gpm. For heads with 1-in or larger inlets specify a prefabricated swing joint of appropriate size.
- e. Pre-Bury Pipe Inspection Form
 - (a) All pipe shall be inspected by the University Irrigation Shop before it can be buried. When pipe has passed inspection, the University's representative will give the Contractor a pipe inspection form indicating which areas of pipe have passed. If pipe has not passed inspection, the University reserves the right to have the pipe dug up to insure it meets the standards noted herein.

(3) Sleeves

- a. Specify all sleeves to be PVC Class 200 minimum, two sizes larger than the total outside diameter of the piping contained in the sleeve. Sleeves shall be a minimum of 2-in. Specify the depth of installation for lateral and main lines. Coordinate the installation of sleeves with the location and installation of all hard surfaces. Require the Contractor to mark the location of all sleeves by attaching a locating magnet in both ends of the sleeve, and mark their location on record drawing. Where sleeves are buried under hardscape, instruct the Contractor to mark the location of each sleeve by installing a magnetized masonry nail, flush with the hardscape, indicating the location of each end of the sleeve. Insure that adequate amounts of sleeves are specified for both water lines and electrical control wires. Wires shall be in a sleeve separate from pipe, and wire sleeves shall be gray PVC Schedule 40 electrical conduit.

(4) Fittings

- a. Fittings for pipe sizes 3-in and over will be specified ductile iron gasketed fittings. If gasketed pipe fittings (elbows and tees) are used, these shall be thrust blocked against undisturbed soil. Refer to Details LS-1, LS-2, and LS-3, Thrust Blocking - Gasketed Piping / Sizing Procedure.
- b. Fittings on main and lateral lines 2-in and larger will be specified Schedule 80 pressure rated PVC.
- c. Fittings on lateral lines smaller than 2-in diameter shall be specified Schedule 40 pressure rated PVC.
- d. Flex Swing Fittings
 - i. Approved manufacturers and models for fittings on flex swing pipe shall be Rain Bird SB Series spiral barb fittings, Lasco Blue Twister, Toro Super Funny Pipe fittings, or approved equal.
- e. Do not allow galvanized fittings of any kind on any PVC lines or fittings.

(5) Non-Electric Valves

- a. Ball Valves
 - i. Specify ball valves to be domestic solid brass, meeting Federal Specification WW-V- 54, CLASS A TYPE 1. Valve sizes are to be the same size as the line on which installed. Specify ball valves as isolation valves on the upstream side of automatic valve clusters and place these valves in a standard valve box.
- b. Stop and Waste Valves
 - i. Specify stop and waste valves to be solid brass meeting Federal Specification WW-V-54, CLASS A, TYPE 1. Valve sizes are to be the same as the line size on which installed. This valve shall be installed below the frost line. Specify access to each valve by an appropriately sized PVC standpipe, and specify an 8-in round box to cover each valve. The round box shall be stabilized on brick, and with a 12-inch gravel sump beneath the valve.
- c. Hose Bib
 - i. Specify one hose bib per group of valves. The hose bib is to be installed on a manufacturer assembled Schedule 80, swing joint. See Detail LS-5 for additional information.
- d. Quick Coupler Valve

- i. Specify one quick coupler valve to be installed downstream of, and close to, the backflow preventer. The quick coupler valve is to be installed downstream of the master valve/flow sensing device.
 - ii. The quick coupler valve shall be a, two-piece, one inch, brass valve. Approved manufacturers and models shall be Rain Bird 44NP, Buckner QBRB5NP10, or Hunter Industries HQ-44LRC-NP.
- (6) Electric Remote Control Valves
 - a. Installation
 - i. Specify each valve to be installed using Schedule 80 piping on both the upstream and downstream sides, to extend beyond the valve box. Refer to Detail LS-4, Ball Valve Assembly and LS-7, Valve Manifold.
 - b. Specification Requirements
 - i. Specify electric remote control valves using the following requirements:
 - ii. One inch valves shall be plastic, approved manufacturers and models Rain Bird 100-PEB, Hunter Industries ICV-101G, or Toro 220-P:
 - (a) Glass-filled nylon reinforced bodies
 - (b) Fabric-reinforced diaphragms
 - (c) Brass flow control stem
 - (d) Manual external bleed
 - (e) Capability to operate low flows of .25 gpm or less
 - (f) Optional pressure regulating device available
 - (g) 1-in valves shall be designed with a minimum of 5-gpm and a maximum of 24-gpm for load.
 - iii. Valves larger than 1-inch shall be brass. Approved manufacturers and models shall be Toro 220 Series valves, Rain Bird GB, Hunter IBV.
 - (a) Corrosion resistant brass body and bonnet.
 - (b) Fabric-reinforced diaphragms.
 - (c) Manual external bleed.
 - (d) Optional pressure regulating device available. The pressure regulating device shall be serviceable while the main line is under pressure. The device shall not be installed under the solenoid.
 - (e) 1-1/2-in valves shall be designed with a minimum of 25 GPM and a maximum of 34 GPM for load. 2-in valves shall be designed with a minimum of 35 GPM and a maximum of 75 GPM for load.
 - (f) Zone size shall not exceed 75 GPM
 - iv. Specify that all valves will be tagged with University Landscape Maintenance Department approved tag indicating the appropriate controller and station number.
- (7) Electric Control Wire
 - a. Wire Specifications
 - i. Electric control wire shall be specified polyethylene (PE) UF/UL DIRECT BURIAL type. Wire which is routed from the electric remote control valve to the controller shall be #14 AWG. PVC coated UF/UL type wire shall not be used.

- ii. Specify all wiring to be direct run with no splices except as noted in below. Include a statement in the construction documents that wire outside of valve manifold cannot be spliced without the approval of the University Project Manager and Landscape Maintenance.
 - iii. The specifications shall require an extra or "spare" control wire provided to each valve group. This spare wire shall not be a single wire looped throughout the site. Five valve groups require five spare wires.
- b. Wire Color
- i. Wire coloring shall follow the following coding:
 - (a) Ground wire shall be green.
 - (b) Common wire to a valve shall be white.
 - (c) Controller electrical power wire shall be black.
 - (d) Master valve wire, other than the common wire, shall be orange.
 - (e) Flow sensing wire, other than the common wire, shall be Purple.
 - (f) Each control wire extending to a valve shall have a different color wire for each valve, excluding those colors designated for other purposes i.e. green, white, black, purple and orange.
- c. Splices
- i. Splices in electric control wire at the electric remote control valve shall be twisted together, then soldered and fitted with a direct bury UL listed wire connector. All splices shall be contained in a valve box.
- (8) Electric Controller
- a. Rain Bird ESP
- i. All clocks shall be equal to a Rain Bird ESP-SAT-LS or LW series controller or approved equal, installed according to manufacturer's instructions. Models within the series shall be -SITE-SAT, -SAT-LINK or -SAT-TW. Controller station counts shall be 24 or 40 only, no other count configurations allowed. Controllers shall be provided with a Rain Bird RB-SE-MET Ethernet device server. Refer to Detail LS-11, Pedestal Mounted Controller.
 - ii. The exact location of the clock shall be approved by the Landscape Maintenance Department.
 - iii. The controller shall be located such that it can communicate clearly to the University's central computer. A radio site survey is required to verify transmission clarity.
 - iv. All controllers shall be compatible with the University's existing central control system. Alternate manufacturers must be prior approved before bidding. Before prior approval will be considered, proposed products will be required to undergo on-site compatibility testing under direction of the University.
 - v. Central control equipment including but not limited to CCU's and controllers shall be commissioned, tested and approved by a Factory Authorized Service Technician from a local Rain Bird Authorized Distributor, before substantial completion will be granted. This task shall be at the Contractor's expense.
 - vi. Cluster Control units shall be model CCU-28, with a Rain Bird RB-DS-MPX Multiplexer and a RB-SE-MET Ethernet device server.
- b. Grounding

- i. Require the Contractor to ground all clocks according to manufacturer's recommendations, using either a three rod grounding grid or a grounding plate with a rod combination. See grounding details. If a three rod grounding triangle cannot be installed, contact the University Project Manager and the Landscape Maintenance Department.
 - ii. The grounding plate shall be manufactured for the express purpose of grounding. The plate shall measure a minimum of 4 inches by 96 inches, and no thinner than six one-hundredths of an inch.
 - iii. Grounding rods shall be 8-ft long, 5/8-in minimum diameter solid copper. Rods shall be placed a minimum of 8-ft apart.
 - iv. Connect rods and/or plate using #6 AWG or larger bare, solid copper wire to interconnect all rods.
 - v. Wire shall be run as straight as possible, with a bend of no tighter than ninety degrees and a radius no smaller than eight inches going into the controller. The ground wire entering the controller shall be of the shortest possible length and contain no bends kinks or coils in the wire.
 - vi. All grounding shall be tested to 10-ohms or less.
 - c. Central Control Radio Signal
 - i. The controller shall include radio signal access to the University's central controller. This shall be done by installing a 900 MHz spread spectrum radio card into the controller which is compatible with the controller. The radio card will be attached to a 900 MHz, 3db gain, antenna mounted on the controller. If the need for an antenna with a larger DB gain is determined, then the antenna of appropriate size shall be attached to the radio card and controller.
 - d. Controller hand-held Radio Remote Card
 - i. The controller will include a radio remote card compatible with the University's radio remote system. This card shall be connected to a compatible radio antenna, permanently installed, and transmitting at 27-MHz, Preferred antenna shall be TRC Irrigation Remotes model 35-001-006 low profile 'hockey puck' antenna, or approved equal.
 - e. Antenna Location
 - i. Antennas shall be installed at least forty feet away from electric motors, large power transformers, power lines, variable-frequency drives and other devices with a high level of electrical noise which could affect communication from the controller to the CCU. All antennas shall be permanently mounted on the exterior of the controller cabinet, nearby building or fixture. Antennas shall be positioned such that they are three feet away from all vertical surfaces and out from underneath roof awnings.
- (9) Master Valve / Flow Sensor
- a. The master valve and flow sensing device shall be a single, combined, unit with the capability of adding pressure regulation where needed, Netafim Reed Switch, Normally Closed models, LHMXXTG1-MEL or LHMXFG1-MEL, or approved equal. Photo Diode and normally open models shall not be specified. The valve shall be designed for high pressure, remote control applications via 14 AWG PE wire. The unit shall be double-chambered, and made of polyester coated cast iron, with a reinforced natural rubber valve diaphragm. No straight length of pipe will be

required upstream or downstream of the device. Only globe configured valves will be used.

b. Add Brass Ball Valves

- i. When ports are available on the valve, two brass ball valves will be added to the valve, attached by two brass nipples, to allow for drainage and winterization of the valve.

(10) Backflow Prevention

a. Reduced Pressure Assembly Valves

- i. Specify backflow preventers to be approved reduced pressure assembly valves with accessory construction, modular design, and replaceable seats. Specify this valve assembly to meet the following standards: ASSE No. 103; AWWA C506-78; CSA b65.4; and, FCCCCHR of USC. This valve shall be serviceable "in line" and have ball valve test cocks and valves on both sides for testing.

b. Installation

- i. Installation will be on the main line in an accessible location.

c. Site Location

- i. The exact location for the reduced pressure assembly is to be approved on site by the Landscape Maintenance Department. Specify the reduced pressure assembly to be installed above ground in a lockable metal enclosure approved by the Landscape Maintenance Department. See Detail drawing LS-17.

d. Drains

- i. Specify the installation of drains upstream and downstream of the reduced pressure assembly. These shall be 'American made' brass stop and waste valves. Specify each drain to be provided with a gravel sump 12-in x 12-in x 12-in filled with 1-in minus washed gravel. Each drain is to be accessible by an appropriately sized PVC standpipe and covered with an 8-in round box. The round box shall be stabilized on brick, and installed with a 12-inch-deep gravel sump beneath the valve.

(11) Heads

a. Spray Heads

- i. Spray heads shall be Rain Bird RD-XX-S-P30 or Hunter PROS-XX-PRS30-CV series spray heads, or approved equal, of appropriate height for the plant material it services.
- ii. At no time use the side inlet.
- iii. Heads shall have the following characteristics:
 - (a) UV resistant plastic.
 - (b) Stainless steel spring.
 - (c) Retractable stem that flushes while retracting.
 - (d) Ratcheting riser.
 - (e) Five-year warranty.

b. Small Rotors

- i. Small rotors shall be approved manufacturers and models: Rain Bird 5000-PL-XC-SAM-R series, Hunter I-20-XX-CV.
- ii. Small Rotors shall have the following characteristics:

- (a) A radius of 25 to 50 feet.
 - (b) Durable, commercial grade body, cap and riser top.
 - (c) A flow shut off mechanism in the rotor such that water can be cut off to the head while the lateral irrigation system is still in operation.
 - (d) All rotor adjustments like arc, head shut-off, radius, nozzle set screw, riser access, shall be readily accessible from the top of the head.
 - (e) A twelve inch, four inch, and stainless steel riser options.
 - (f) A ratcheting or slip clutch riser.
 - (g) Low angle and matched precipitation rate nozzles shall be available.
 - (h) An optional built in check valve that can hold back at least seven feet of water due to an elevation change of the pipe.
 - (i) Five-year trade warranty.
 - (j) A matched precipitation rate nozzle package for 25, 30 and 35-foot radius of coverage.
- c. Large Rotors
- i. Large rotors shall be approved manufacturers and models, Rain Bird 8005 series rotor, Hunter I-25 series rotor.
 - ii. Large rotors shall have the following characteristics:
 - (a) A radius of 39 to 60 feet.
 - (b) Durable, commercial grade body, cap and riser top.
 - (c) Brass reinforced nozzle to riser connection.
 - (d) Vandal resistant arc adjustment that will return to a user defined arc.
 - (e) In-head option to change from part-circle to a continuous 360°, true full circle, head.
 - (f) All rotor adjustments like arc, head shut-off, radius, nozzle set screw, riser access, shall be readily accessible from the top of the head.
 - (g) A stainless steel riser option.
 - (h) Built-in check valve that can hold back ten feet of water due to an elevation change of the pipe.
 - (i) Five-year trade warranty.
- (12) Nozzles
- a. No variable arc nozzles for spray heads will be allowed.
 - b. Multi-Stream Rotary Nozzles
 - i. Multi-stream rotary nozzles for spray heads are allowed, approved manufacturers and models: Hunter Industries MP Rotator nozzles, Rain Bird RVAN nozzles. The radius of arc shall be adjustable from the top of the nozzle. Multi-stream nozzles shall be installed on spray heads with pressure regulated stems.
- (13) Head Location
- a. Drawing Requirements
 - i. Show all irrigation head locations on drawings diagrammatically. Although the Contractor will be required to exactly determine the location of each head for proper coverage, the A/E shall exercise all due diligence in establishing head

- spacing, head specifications for best coverage, and piping design for minimum pressure loss to provide peak headperformance.
- ii. After due diligence in the design, the A/E shall include a note on the drawings indicating:
 - (a) "It shall be the Contractor's responsibility to determine the exact location of each irrigation head to accommodate the conditions found on the site in order to provide COMPLETE coverage of all areas. If a deficiency is found during the installation process, contact the University Project Manager and the landscape consultant at that time."
 - b. Manufacturer's Recommended Spacing
 - i. The A/E's design shall locate sprinklers at 90% OR LESS, of the manufacturer's published coverage radius. The A/E shall also use the manufacturer's published optimum pressure recommendation for the respective sprinkler head. (i.e. using a pressure rating higher than the published recommendation in order to justify increased spacing is not acceptable) Site conditions such as wind or slope may require tighter spacing than the 90%. At no time shall the A/E match or exceed the manufacturer's published coverage for spacing.
 - c. Layout Adjustments
 - i. Do not allow the Contractor to make adjustments in the designed layout unless prior approved to clear existing fixed obstructions.
 - ii. Direct the Contractor to note all deviations from the drawings on the as built drawings.
 - d. Perpendicular & Flush to Finished Grade
 - i. Specify all irrigation heads to be set perpendicular and flush to the finished grade unless otherwise designated on the drawings and specifications.
 - e. No Mixed Head Types
 - i. The design shall not mix head types in a zone. All heads shall be matched precipitation rates within a sprinkler zone.
 - f. The design shall not have head to head coverage extending through fencing or other barriers, or over walks or pavement. Mow curbs, paths, walks shall be border watered with part circle heads on both sides.
- (14) Valve Boxes
- a. Installation Requirements
 - i. Specify each valve box to be placed on a bed of 1-in minus washed gravel 6-in deep below the valve box. Use the same manufacturer's valve boxes throughout the construction site, Carson & Brooks, tee top lids. Additionally, direct the Contractor to set the box on a foundation of pressure treated wood frame or brick, which is placed on well compacted, undisturbed soil. Note that there shall be 2-in clearance between the base of the valve and the gravel bed. Also note that there shall be 2-in clearance between the top of the valve and the valve box lid. Valve boxes shall be green in color only. Specify that all valve box lids shall be 'lipped' or 'T' cover configuration, not 'flush' cover configuration. Specify that all valve box lids shall have labels branded into lid, using a device same as or similar to Nova Tool Co. model BI-CC-XX 2-in bronze letters. Box branding shall be as follows:

BOX LID BRANDING LABEL	ITEM OR EQUIPMENT IN THE BOX
XXX – YY	Controller #XXX – Station #YY
ISO	Isolation or Line Valve
WS	Wire Splice
S/W	Stop & Waste Valve
QC	Quick Coupler
HYD	Hydrometer
GND	Grounding Equipment

b. Site Location

- i. The Contractor shall be directed to install all valve boxes no closer than three feet from sidewalks, curbs, and all hard surfaced areas. Where three feet clearance from hardscape is not possible, locate the valve box as far as practical from areas of vehicle traffic. Do not allow the Contractor to install valve boxes at the low point of the landscaping.

c. Valves in Box

- i. Limit the number valves per valve box. The maximum number allowed in each box is shown in the chart below:

VALVE BOX SIZE	ELECTRIC VALVE SIZE AND QUANTITY
Standard Valve Box	One Valve per Box
Jumbo Valve Box	One 2-in Valve, or Two 1-1/2-in Valves, or Two 1-in Valves
Little Giant	Two 2-in Valves, or Three 1-1/2-in Valves, or Three 1-in Valves
Giant	Three 2-in Valves, or Four 1-1/2-in Valves, or Four 1-in Valves

(15) Trenches

a. Lateral Lines

- i. Specify trenches for lateral lines to be dug such that a minimum of 8-in and a maximum of 18-in of cover on top of the pipe, and as wide as necessary to properly install piping.

b. Main Lines

- i. Specify trenches for main lines to be dug a minimum of 18-in deep (from grade to top of pipe) and as wide as necessary to properly install piping.

- ii. Direct the Contractor to route all electrical wiring in the main line trench as shown on Detail LS-12, Trench Detail. Require the Contractor to attach the electrical wires every 15-ft with tape to the underside of the main line.
 - c. Multiple Pipes
 - i. Require trenches with more than one pipe installed to have a pipe separation distance of 4-in between each pipe. No exceptions will be considered for this requirement.
 - d. Buried Wire
 - i. Wire not in a main line trench shall have a minimum of 12-in of cover to finish grade. Wire will be buried below and to the side of pipe with a separation from the pipe of no fewer than 3 inches.
 - e. Location
 - i. Specify that trenches shall be at least 12-in away from curbs, buildings, and sidewalks; and, three feet from all roads. No exceptions will be considered for this requirement.
 - f. Backfilling of Trenches
 - i. Instruct the Contractor to backfill around and over the pipes in accordance with Detail LS-12, Trench Detail. All material that is to come in contact with the pipes shall be less than 1/4-in in diameter and shall be imported for this specific use. The existing material on site can only be used as backfill material above the piping upon the approval of the A/E; then, it may be used in accordance with Detail LS-12. Compaction requirements shall generally be 95% under walks and roadways and 85% in lawn and shrub areas, unless information shown on Detail LS-12 or elsewhere on the drawings is more restrictive.
- (16) Drip and Sub-Surface Irrigation Systems
- a. Manufacturer's Recommendations
 - i. Direct the Contractor to follow manufacturers' recommendations for installing drip irrigation systems.
 - b. No Point Source Systems
 - i. No point-source systems shall be permitted on University projects.
 - c. Use End Feed / Grid Design
 - i. Design drip systems using an end feed, grid design.
 - d. End Feed Piping
 - i. End feed pipes at each end of the grid (also known as footers, headers, or exhaust pipes) shall be 1-in Schedule 40PVC.
 - e. Manifolds
 - i. Manifolds shall include the following devices, in this order:
 - (a) Brass isolation ball valve.
 - (b) Use an automatic valve. Do not exceed 14-gpm per zone.
 - (c) Manifold union.
 - (d) Disc filter with 140 mesh disc filter rings, of appropriate size.
 - (e) In-line pressure regulator valve of appropriate size and flow.
 - ii. All of the devices in the manifold shall be spaced such that all of the devices are fully operational and accessible for maintenance purposes.

- f. Drip Tube Requirements
 - i. Use inline drip tubing, approved manufacturers and models Netafim Techline CV or Rain Bird XFCV.
 - ii. Drip tubing shall be pressure compensating, have a continuously self-flushing drip emitter design, and have a 2-psi check valve in each emitter.
 - iii. Direct the Contractor to bury the tubing 2 to 5-inches. Do not place tubing under weed barrier fabric.
 - iv. Require anchoring the drip tubing with stainless steel soil staples every 4 feet. Use two soil staples at each tee, elbow or cross.
 - v. Place manual line flushing valves at each dead end, and low point in the system. Line flush valves shall be placed in a 10 inch round box, stabilized on brick, and with a 12-inch gravel sump beneath the valve.
 - vi. Tubing shall be 0.40, 0.60 or 0.90 GPH set at 18-in emitter spacing in tubing. Tubing row spacing shall be uniform at 18-in on center.

(17) Flushing and Preliminary Testing

- a. Direct the Contractor to flush and test each zone after installation of new piping, swing pipe, and prefabricated swing joints, but before installation of irrigation heads and before trenches have been completely backfilled. The control valve shall be opened fully and a full head of water used to flush out the system. Each automatic valve shall then be disassembled, inspected for rocks, cleaned, and reassembled. Install irrigation heads and test each zone for complete coverage.
- b. Specify that testing will be performed after completion of each circuit, and again after completion of the entire system. At this time any necessary repair work will be done at the Contractor's expense and the entire system will be in good working condition prior to the Substantial Completion Inspection.

(18) Winterization

- a. All irrigation systems at the University are winterized starting October 15th. If the Substantial Completion Certificate has not been issued before winterization, it will be the responsibility of the Contractor to coordinate with the Landscape Maintenance Department Irrigation Shop regarding winterization, and the Contractor shall be responsible to winterize the system and prevent all components from freezing. Require the Contractor to then be responsible to activate the system in the Spring, with the assistance of the Landscape Maintenance Irrigation Shop to insure there are no problems.

(19) Irrigation System Guarantee

- a. All work shall be guaranteed for compliance with the drawings and specifications for a period of one year after the date of Substantial Completion. The Contractor shall correct any deficiencies when notified during the warranty period, and additionally correct, to the satisfaction of the University, any damage to buildings or grounds caused by the deficient work, without cost to the University. All guarantees shall be in writing and approved by the A/E before submitting to the University. The written guarantee is due to the A/E for review and approval on or before the date of Substantial Completion.

B. Submittals prior to Construction

- (1) No additional University requirements.

C. Submittals prior to Substantial Completion

- (1) Prior to the Substantial Completion inspection, require the Contractor to coordinate with the University's Irrigation Department to subcontract with a Certified Landscape Irrigation Auditor (CLIA), at the Contractor's expense. At a pre-approved time and date, the Contractor's CLIA auditor will be directed to a location or locations specified by the University to conduct the audit. The Substantial Completion Inspection will not be authorized until the CLIA report is acceptable to the University.
- (2) During the Substantial Completion Inspection, the entire system, both electric and hydraulic, will be tested in the presence of the A/E, the Landscape Maintenance Department, and the University Project Manager to insure complete coverage of all areas to be watered. This test shall be performed by using the irrigation controller. Any deficiencies identified at this time will require revisions by the Contractor at the Contractor's expense.

5.0 HIGH PERFORMANCE BUILDING SYSTEMS

The DFCM HPBS shall be followed on all University projects, along with the additional University requirements detailed below.

5.1 LEED Requirements

- A. All University of Utah projects exceeding \$10 million of construction costs and which constructs a new building or an addition to an existing building shall meet the following additional minimum standards, unless the Chief Design and Construction Officer (CDCO) of the University of Utah approves an exception. The CDCO may not approve an exception for a new building without first consulting with the University President.
- B. The project shall achieve a minimum of Silver Certification under the current LEED standard if the project is of a type for which LEED Certification is applicable.
- C. The project shall specifically achieve the LEED credits as outlined in [Table 5.1](#)
 - (1) Table 5.1 is not inclusive of all credits allowed under LEED but shows the required credits in the University’s Design Requirements as listed under *University of Utah LEED Conditions* column.
 - (2) The *DFCM HPBS Requirements* column shows the DFCM High Performance Building Standard items that shall be followed in addition to the University’s requirements.
 - (3) HPBS requirements not listed are either not as strict as University’s Design Requirements or not as strict as LEED requirements. LEED credits that are not listed but would be required to achieve LEED Silver can be pursued at the design firms' discretion as long as the outcome is a minimum of LEED Silver certification.
 - (4) [Table 5.1](#) is a quick reference guide of how LEED Silver, the University’s Design Requirements and DFCM HPBS relate to each other in order for projects to meet LEED and HPBS design requirements. Design teams are responsible to verify requirements in HPBS and LEED and report any discrepancies to the Project Manager for clarification.

TABLE 5.1: QUICK REFERENCE GUIDE FOR THE UNIVERSITY’S LEED STANDARDS AND THE DFCM HIGH PERFORMANCE BUILDING STANDARDS

LEED CATEGORY OR PREREQUISITE	LEED CREDIT NAME	UNIVERSITY LEED STANDARDS	DFCM HPBS REQUIREMENTS
Prerequisite	Integrated Project Planning and Design	Prerequisite for “Healthcare”. Highly recommended for all other projects.	Projects shall follow HPBS 5.15 (Owner’s Project Requirements)
Credit	Integrative Process	Required	Project must follow HPBS 5.1 (Integrated Design Process)
LOCATION AND TRANSPORTATION			
LT	Sensitive Land Protection	Highly Recommended	
LT	Surrounding Density and Diverse Uses	Highly Recommended	
LT	Access to Quality Transit	Highly Recommended	
LT	Bicycle Facilities	Required	

LT	Reduced Parking Footprint	Lack of building specific parking on campus make this credit challenging. May require “Campus” or “Group Approach” to comply	
LT	Green Vehicles	Lack of building specific parking on campus make this credit challenging. May require “Campus” or “Group Approach” to comply	Project shall follow HPBS 5.3 E (Transportation Management-parking stalls)
SUSTAINABLE SITES			
SS	Rainwater Management	Required; following campus design standards will meet the credit requirements of Path 2	
SS	Heat Island Reduction		Project shall follow HPBS 5.4 D (Heat-Island Effect)
SS	Light Pollution Reduction	May require “Campus Approach” to apply	Project shall follow HPBS 5.4 E (Light Pollution Reduction)
SS	Construction Activity Pollution Protection - prerequisite	Required: Coordinate with Occupational and Environmental Health and Safety for potential additional campus requirements	
SS	Environmental Site Assessment – prerequisite	Required for Healthcare	
SS	Site Assessment	Highly Recommended	
WATER EFFICIENCY			
WE	Outdoor Water Use Reduction	Required; project shall earn a minimum of 1 point	
WE	Indoor Water Use Reduction	Required; project shall earn a minimum of 2 points	
WE	Water Metering	Highly Recommended	
ENERGY AND ATMOSPHERE			
	General	HPBS requirements are mandatory	Project shall follow HPBS 5.14 (Incentives and Rebates) Please also see Materials and Resources HPBS 5.5 B requirement (Appliances and Equipment)

EA	Fundamental Commissioning and Verification Prerequisite		Project shall follow HPBS 5.12 (Commissioning) and HPBS 5.13 (Envelope Commissioning)
EA	Building-Level Energy Metering Prerequisite	Following the DFCM HPBS will meet LEED requirements	AND project shall follow HPBS 5.10 (Metering)
EA	Enhanced Commissioning	Required; project shall earn 6 points (Option 1: Path 2 and Option 2).	Project shall follow HPBS 5.12 (Commissioning) and HPBS 5.13 (Envelope Commissioning)
EA	Optimize Energy Performance	Required; project must earn a minimum of 13 points exclusive of consideration of cogeneration at the U. Cogeneration may be used in the LEED submittal, however.	Project may not go below threshold set in HPBS 5.5A(1) without DFCM review and approval
EA	Advanced Energy Metering	Required. This credit is well aligned with the metering requirements of DFCM HPBS	Project must follow HPBS 5.10 (Metering)
EA	Demand Response	Projects considering this credit should work closely with UU Energy Management office.	
EA	Renewable Energy Production	Highly Recommended. Coordinate with Energy Management and Sustainability Office for potential additional funding opportunities.	
MATERIALS AND RESOURCES			
MR	General	HPBS requirements are mandatory.	Project shall follow HPBS 5.5 B (Appliances and Equipment) Project shall follow HPBS 5.7 B (Water bottle filling stations) Project shall follow HPBS 5.7 D (Sustainable Material Sourcing)
MR	Building Product Disclosure and Optimization-- Environmental Product Declarations	If this credit is achieved along with Building Product Disclosure and Optimization-- Sourcing of Raw Materials, then the project does not need to follow DFCM HPBS 5.7 D (1), 5.7 D (2), and 5.7 D (3).	

MR	Building Product Disclosure and Optimization--Sourcing of Raw Materials	Please see above note regarding Building Product Disclosure and Optimization--Environmental Product Declarations.	
MR	Construction and Demolition Waste Management	Required; project shall earn a minimum of 1 point. Provide final Waste Report documentation to UU Sustainability Office	
MR	Construction and Demolition Waste Management Planning – Prerequisite	Provide final plan and documentation to UU Sustainability Office	
MR	Storage and Collection of Recyclables - Prerequisite	Coordinate design approach with Facility Operations Recycling and Sustainability Managers.	
	PBT Source Reduction – Mercury (Prerequisite for Healthcare)	Required for Healthcare	
INDOOR ENVIRONMENTAL QUALITY			
IEQ	Low-Emitting Materials		If the LEED credit is not pursued, projects shall follow HPBS 5.8 (Indoor Environmental Quality) Sections C, D and E
IEQ	Construction Indoor Air Quality Management Plan	Required	
IEQ	Indoor Air Quality Assessment	Required	
IEQ	Interior Lighting	Option 2 of this credit is required; individual spaces that require specialty finishes based on functionality may be exempted from this requirement as identified in programming documents	If LEED Credit Option 1 is not pursued, then the project shall follow HPBS 5.8 H (Task and overhead lighting)
IEQ	Daylight		If the LEED credit is not pursued, project shall follow HPBS 5.8 I (Access to daylights and views)
IEQ	Quality Views		If the LEED credit is not pursued, project shall follow HPBS 5.8 I (Access to daylights and views)

INNOVATION			
	Innovation	Required; project shall earn 1 innovation point that meets or exceeds the requirements in DFCM HPBS 5.9 (Education and Outreach Program)	

5.2 University's Measurement and Verification Plan

A. Introduction

- (1) In order to encourage better project design, enable better building operation and account for increased energy savings and reduced emissions, the University developed this Measurement and Verification (M&V) Plan. The purpose of this M&V Plan is to establish a consistent method for quantifying the performance of energy conservation measures by comparing actual energy consumed by a building, its systems and subsystems to the predicted energy consumption developed during project design. All projects shall comply with the University's Measurement and Verification Plan.
- (2) The basis of this M&V Plan is the Efficiency Valuation Organization's International Performance Measurement and Verification Protocol (IPMVP). *IPMVP Volume 1: Concepts and Options for Determining Energy and Water Savings* (available at www.evo-world.org) outlines four options (Options A through D) for measuring and reporting a project's savings. Option B: Retrofit Isolation: All Parameter Measurement is the only option allowed under this M&V Plan.
- (3) Compliance with this M&V Plan will provide a path for projects registered under LEED to earn EA Credit: Enhanced Commissioning, Option 1 Path 2 and for projects registered under LEED to earn the Advanced Energy Metering credit. Additionally, compliance with this Plan will assist the University as it works to meet its commitments to sustainability and energy efficiency including the American College and University President's Climate Commitment (climate neutrality by 2050) the Better Buildings Challenge (20% reduction in energy intensity by 2020).

B. Project Specific Measurement and Verification Plan Requirements

- (1) A project specific Measurement and Verification Plan shall be developed by the design team along with the development and design of energy conservation measures. All design strategies and devices needed to fulfil the M&V Plan shall be budgeted in the project and included in project documents. Details of the Plan shall be coordinated with Facility Operations/Energy Management. The following outline represents the minimum requirement for a project specific M&V Plan and is designed to meet the needs of LEED EA Credit Enhanced Commissioning Option 1, Path 2.
 - a. Table or listing of project's energy end uses and which are monitored
 - b. Indication of the location of all monitoring devices
 - c. Specific information regarding the baseline conditions established for the project
 - d. Specific information regarding the method/frequency for analysis against the documented baseline conditions

C. Metering Requirements

- (1) Energy and water meters are fundamental to meeting the requirements of this M&V Plan. Utility grade meters shall be installed at the building level for each utility feeding each

building or major subunit of a complex. Sub-metering shall be installed on each subsystem as required by the project specific M&V Plan. Sub-metering shall also be installed to isolate any functional and/or billable subdivision within a building. In addition to metering devices, data acquisition devices shall be installed in each building to enable communication between each metering device and the University's Energy Information System (EIS) and/or Building Automation System (BAS). Details of the required metering and meter communications shall be coordinated with Facility Operations/Campus Utility Services and Energy Management.

- (2) Following is an outline of basic metering and data requirements. This is a general list; exact metering shall be based on specific building requirements as outlined in the project specific M&V Plan. (See DFCM HPBS 5.10 for specific meter requirements.)
- (3) Primary metering (utility grade meters)
 - a. Building level. This also applies to separate programmatic spaces (spaces requiring individual energy accounting or billing)
 - i. Electricity
 - ii. Gas
 - iii. Chilled Water
 - iv. High Temperature / Hot Water
 - v. Water
- (4) Sub-metering (utility grade meters not required if alternative means are available)
 - a. Electricity
 - i. Lighting
 - (a) Interior Lighting
 - (b) Exterior Lighting (walkways, parking lots, etc.)
 - (c) Special use lighting (athletic fields, etc.)
 - ii. Plug loads
 - iii. High Intensity/Process Loads (data centers, specific equipment)
 - iv. HVAC System Equipment (fans, pumps, etc.)
 - b. Thermal Energy
 - i. Primary Heating (boilers (gas), heat exchangers (btu))
 - ii. Domestic Hot Water (water heaters (gas), heat exchangers (btu))
 - iii. Primary Cooling (chillers (electrical), heat exchangers (btu))
 - iv. Pressure/temperature ports on hydronic equipment, such as cooling and heat coils.
 - c. Water
 - i. Irrigation
 - ii. Domestic
 - iii. Mechanical water usage (makeup/feed water)
- (5) Data Requirements
 - a. Meters to provide instantaneous data to BAS for operational monitoring of HVAC system
 - b. Meters to provide 15-minute interval data to EIS for trending and analysis
 - c. Electrical meters to report volts, amps, power (kW), energy (kWh), etc.

- d. Gas meters to report pressure and temperature compensated volume in hundred cubic feet (CCF) or thousand cubic feet (MCF)
 - e. Chilled and High Temp/Hot Water meters to report flow in gallons per minute (gpm), supply and return temperature, energy (kBtu or MMBtu)
 - f. Water meters to report volume in cubic feet (CF) or gallons
- D. Responsibility and Accountability
- (1) It is the responsibility of the design team to develop the project specific M&V Plan. The design team shall ensure all required metering devices are budgeted and included in the design documents. It is the responsibility of the project team (design team, contractors, commissioning agent) to verify that all metering devices are reporting, recording, and communicating prior to project substantial completion.
 - (2) It is the responsibility of the University (Facilities Management/Facility Operations) to provide coordination and information to the design team in support of developing the project specific M&V Plan. Upon substantial completion, the University will take ownership of Measurement and Verification Plan and the process of collecting and reporting data.

6.0 SUMMARY OF PRODUCTS AND VENDORS

6.1 General

- A. The intent of this section is to provide a central repository for the manufacturers, vendors and products that are found in the University Design Requirements, and are therefore specifically needed by the University. This section lists items with approved products, manufacturers, vendors, etc., (one product or a small group of products) which represent the required quality standard for each item. Some of these items are “sole source” and will be specified without the opportunity for substitution.
- B. During the bidding process and prior to the bid due date, the A/E will assist the University in the evaluation of substitution requests (prior approval requests) submitted by vendors / suppliers. Refer to [1.5](#) for University Approved Equal requirements.
- (1) These requests for prior approval will generally be submitted by the A/E no later than a deadline established by Facilities Business Services and placed in the bidding documents.
 - (2) Each substitution request will be evaluated by the A/E who will forward a summary of its recommendations to the University in a proposed addendum format for University review. The A/E will submit the proposed addendum to both the University Project Manager and to Facilities Business Services/Contracts. The University Project Manager will distribute the proposed substitutions to Facilities Management for review.
 - (3) Upon approval of the A/E’s recommendation by Facilities Management, Facilities Business Services will post the A/E’s addendum in the University’s web based bid system.
 - (4) The A/E shall not distribute addenda to bidding contractors / vendors.
- C. Product changes or special design circumstances may suggest a deviation from these standards. For all University projects, any anticipated change to, or variance from any portion of the supplement will require a review by the Design Standards Committee. Refer to [1.2 B](#). Each request for change or variance shall be submitted through the University Project Manager to the committee on the appropriate form found in [Design Process, University of Utah Supplement](#) or on the Facilities website.

6.2 List of University Approved Products

A. Civil Products

LOCATION	PRODUCT DESCRIPTION	UNIVERSITY APPROVED VENDOR / MGFR	PROCUREMENT REQUIREMENT
3.2 A (2)	ADA Curb Ramps	Armorcast Products Company	For Other Products / Manufacturers, Prior Approval is Required

B. Architectural Products

LOCATION	PRODUCT DESCRIPTION	UNIVERSITY APPROVED VENDOR / MGFR	PROCUREMENT REQUIREMENT
3.3 B (3) a.	Roof Boards (High Traffic)	Georgia-Pacific “DensDeck”	For Other Products / Manufacturers, Prior Approval is Required

LOCATION	PRODUCT DESCRIPTION	UNIVERSITY APPROVED VENDOR / MGFR	PROCUREMENT REQUIREMENT
3.3 B (3) b.	Roof Under Overburden	Hydrotech "Garden Roof"	For Other Products / Manufacturers, Prior Approval is Required
3.3 B (4) a.	Roof Membrane Termination Sealant	Dow 795 / 790	For Other Products / Manufacturers, Prior Approval is Required
3.3 B (6) a.	Roof Drain Domes	Josam, Smith, Wade, Zurn	For Other Products / Manufacturers, Prior Approval is Required
3.3 B (7) b.	Roof Penetration Sealant	Dow 890	For Other Products / Manufacturers, Prior Approval is Required
3.3 B (8) a.	Roof Conduit and Pipe Supports	PipePier Support Systems	Similar To (No Prior Approval Required)
3.3 B (10) c.	Roof Curb	Unistrut	Similar To (No Prior Approval Required)
3.3 D (1)	Waterproofing, Fluid Applied	American Hydrotech, Inc. Monolithic Membrane #6125 Grace Construction Products Procor 20, and/or 75 Barrett Company Ram-Tough 250 DM	For Other Products / Manufacturers, Prior Approval is Required
3.3 D (2)	Joint Sealants	<u>Dow 790, Dow 795, Sika WS 290, Sika WS 295</u>	Similar / Equal To (No Prior Approval Required)
3.3 K (2)	Face Brick	Interstate Brick Company (SLC): Baja Brown, Matte Interpace Industries, Inc.: Desert Brown, Wirecut Robinson Brick Company: Colorado Rose	No Other Products / Manufacturers Allowed
3.3 N (7) c.	Electronic Locks	CCure	Sole Source, No Other Products Approved (Standardized Security Requirements)
3.3 N (7) c.	Electronic Locks, Interior, for Buildings without CCure	Essex	Sole Source, No Other Products Approved (Standardized Security Requirements)

LOCATION	PRODUCT DESCRIPTION	UNIVERSITY APPROVED VENDOR / MGFR	PROCUREMENT REQUIREMENT
3.3 N (7) c.	Electronic Locks, Interior, for Doors without Power	Locknetics	Sole Source, No Other Products Approved (Standardized Security Requirements)
3.3 N (7) d.	Cylinder Locks	Schlage "Standard 6 Pin Format" / L Series / ND Series	For Other Products / Manufacturers, Prior Approval is Required
3.3 N (7) d.	Panic Bars	Von Duprin 99 Series or 33 Series	For Other Products / Manufacturers, Prior Approval is Required
3.3 N (7) i.	Door Closers	LCN #4041 Series (domestic mfg.)	Sole Source, No Other Products Approved (Standardized Maintenance Requirements)
3.3 N (8)	Door Openers, Automatic	LCN #4611 or #4622	For Other Products, Prior Approval is Required
3.3 O (6) h.	Rubber Base	Johnsonite , Burke, Roppe, VPI	Similar / Equal To (No Prior Approval Required)
3.3 O (7)	Paints, Interior	Pratt and Lambert ProHide or Cellu-tone or Vitralite Sherwin Williams ProMar 200 Dupont 76 Kwal-Howells Accu-Pro Satin 1910	No Other Products Allowed
3.3 O (7)	Paints, Exterior	Pratt and Lambert, Ameritone , Glidden, Sherwin Williams, Kwal-Howells	No Other Manufacturers Allowed
3.3 O (8)	Wall Coverings	Vicretex , Essex	Similar / Equal To (No Prior Approval Required)
3.3 P (1)	Chalkboards and Markerboards	ADP Lemco	Similar / Equal To (No Prior Approval Required)
3.3 P (4) a.	Towel Dispenser (Owner Furnished, Contractor Installed)	Steiner SST	Sole Source, No Other Products Approved (Standardized Maintenance Requirements)
3.3 P (4) a.	Soap Dispenser (Owner Furnished, Contractor Installed)	Ulitmatic L-3	Sole Source, No Other Products Approved (Standardized Maintenance Requirements)

LOCATION	PRODUCT DESCRIPTION	UNIVERSITY APPROVED VENDOR / MGFR	PROCUREMENT REQUIREMENT
3.3 P (4) a.	Toilet Paper Dispenser (Owner Furnished, Contractor Installed)	Ulitmatic S-44C	Sole Source, No Other Products Approved (<i>Standardized Maintenance Requirements</i>)
3.3 P (4) b.	Toilet Accessories	American Specialties, Inc. Bobrick Washroom Equipment, Inc. Bradley Corporation	No Other Manufacturers Allowed
3.3 Q (3) c.	Laboratory Tops	Prime Industries, Laboratory Tops, Inc., Durcon, Epoxyn Products	No Other Manufacturers Allowed
3.3 Q (3) f.	Laboratory Waste and Drain Piping, Substitute for Pyrex	Durcon, Duriron	No Other Manufacturers Allowed
3.3 Q (3) h.	Paper Towel Dispenser, Laboratory Casework	Scott 995	For Other Products / Manufacturers, Prior Approval is Required
3.3 R (1)	Laboratory Casework	Sheldon, Hamilton, Kewaunee, Granite Mill Graniteline	For Other Products / Manufacturers, Prior Approval is Required
3.3 R (2)	Louver Blinds, Horizontal	Bali Classic Blind Series 3000	For Other Products / Manufacturers, Prior Approval is Required
3.3 S (2)	Floor, Waterproof, Washable	Crossfield Products Dex-O-Tex	Similar / Equal To (No Prior Approval Required)

C. Electrical Products

LOCATION	PRODUCT DESCRIPTION	UNIVERSITY APPROVED VENDOR / MGFR	PROCUREMENT REQUIREMENT
3.5 A (3) c.	Fuses for Pole Lights	CooperPower Systems Bussmann KTK-6 with HEB-JJ In-Line Fuse Holder	Sole Source, No Other Manufacturers Approved (<i>Standardized Maintenance Requirements</i>)
3.5 A (3) d.	Pole Light Base Concrete Forms	Sonoco Sonotube	Similar To (No Prior Approval Required)
3.5 A (3) e.	Light Poles, 10' & 20'	Sterner Lighting by Hubbell Lighting, Inc. LSI Industries, Inc.	No Other Manufacturers Allowed (<i>Standardized Maintenance Requirements</i>)

LOCATION	PRODUCT DESCRIPTION	UNIVERSITY APPROVED VENDOR / MGFR	PROCUREMENT REQUIREMENT
3.5 A (3) f.	Walkway Lighting, 10' Pole Light Fixtures	LSI Industries, Inc., Enterprise Round Area Light, Model # SPL – ENS – PT – H – 2 – 100MH – F – MT – BLK – TE – 0450SFTR	Sole Source, No Other Manufacturers Approved (Standardized Maintenance Requirements)
3.5 A (3) f.	Walkway Lighting, 10' Pole Light Fixtures	Beta Lighting, Inc. by Ruud/Cree, Edge Model # ARE–EDR–3M–R5–08–D– UL–BK–350–43K	Sole Source, No Other Manufacturers Approved (Standardized Maintenance Requirements)
3.5 A (3) g.	Parking Lot Lighting, 20' Pole Light Fixtures	Lithonia Lighting, Round Area Light, Model # KVR2 – 250S – SYMFL – 277 – PT4.5 – DBL – LPI	Sole Source, No Other Manufacturers Approved (Standardized Maintenance Requirements)
3.5 E (2) a 3.5 E (4) d.	Cable Mounting in Manhole	Unistrut	Similar To (No Prior Approval Required)
3.5 E (2) a.	Cable Mounting Clamps	ZSI, Inc. Cush-A-Grip	For Other Products / Manufacturers, Prior Approval is Required
3.5 E (2) a.	Cable	Okonite, Kerite Company, General Cable Corporation, Superior Essex	No Other Product / Manufacturers Allowed
3.5 E (2) a.	Splices	Raychem TE, 3M	No Other Manufacturers Allowed
3.5 E (2) a.	Terminations	Thomas & Betts Corporation Elastimold, Cooper Power Systems, 3M, Richards Manufacturing	No Other Product / Manufacturers Allowed
3.5 E (1) c.	Padlock for Switch / Transformer Enclosure Gate	ASSA, Inc. #65190B	Sole Source, No Other Manufacturers Approved (Standardized Maintenance Requirements)
3.5 E (2) b.	Medium Voltage Solid Dielectric Switches	Thomas & Betts Corporation Elastimold G&W Electric Company Eaton VisoVac Fault Interrupter	No Other Manufacturers Allowed
3.5 E (2) c.	Padlock for Switch Cabinet Door	ASSA, Inc. #65190B	Sole Source, No Other Manufacturers Approved (Standardized Maintenance Requirements)

LOCATION	PRODUCT DESCRIPTION	UNIVERSITY APPROVED VENDOR / MGFR	PROCUREMENT REQUIREMENT
3.5 E (4) d.	Grade Ring Sealing System	Sika Corporation "Sikadur Combiflex"	For Other Products / Manufacturers, Prior Approval is Required
3.5 F (1)	N/A		
3.5 F (2)	N/A		
3.5 F (4)	Combination Starters	Eaton Corporation Cutler-Hammer GE Energy Siemens AG	No Other Manufacturers Allowed
3.5 F (5)	Electronic Solid State Starters	Schneider Electric Square D GE Energy Eaton Corporation Cutler-Hammer Siemens AG	No Other Manufacturers Allowed
3.5 G (3)	Padlock for Transformer Cabinets	ASSA, Inc. #65190B	Sole Source, No Other Manufacturers Approved <i>(Standardized Maintenance Requirements)</i>
3.5 G (3)	Distribution Transformers	Cooper Power Systems GE Energy Eaton Corporation Cutler-Hammer Schneider Electric Square D MGM Transformer Company	No Other Manufacturers Allowed
3.5 G (3) b.	Step Down Transformers	Eaton Corporation Cutler-Hammer GE Energy Schneider Electric Square D Siemens AG Synergy Energy, Inc	No Other Manufacturers Allowed

LOCATION	PRODUCT DESCRIPTION	UNIVERSITY APPROVED VENDOR / MGFR	PROCUREMENT REQUIREMENT
3.5 G (4)	Digital Power Meters	Electro Industries/Gauge Tech (EIG) "Shark" GE Energy Schneider Electric Square D "Power Logic"	No Other Manufacturers Allowed
3.5 G (5)	Switchboards / Distribution Boards	Schneider Electric Square D GE Energy Eaton Corporation Cutler Hammer Siemens AG	No Other Manufacturers Allowed
3.5 G (6)	Panel Boards	Schneider Electric Square D GE Energy Eaton Corporation Cutler Hammer Siemens AG	No Other Manufacturers Allowed
3.5 G (9)	Engine Generator Sets	Caterpillar Generac Power Systems Kohler Power Systems Cummins Onan Detroit Diesel	No Other Manufacturers Allowed
3.5 G (9)	Large UPS Systems	Emerson Network Power Liebert MGE UPS Systems, Inc. Mitsubishi Electric Automation, Inc. Toshiba Corporation	No Other Manufacturers Allowed
3.5 H (3) a.	Clock System	Primex Wireless Sapling, Inc.	For Other Products / Manufacturers, Prior Approval is Required
3.5 H (5)	Fire Alarm Systems	FCI (Honeywell Gamewell Fire Control Instruments, Model E3 or S3 Series)	Sole Source, No Other Manufacturer or Vendor will be Approved <i>(Standardized Maintenance / Fire Security Requirement)</i>
3.5 H (5)	Electronic Notifying Pressure Switch (Fire Extinguishers)	MIJA, Inc. "en.Gauge"	Sole Source, No Other Manufacturer or Vendor will be Approved <i>(Standardized Maintenance / Fire Security Requirement)</i>
3.5 H (5) d.	Portable Fire Extinguishers, Electronically Monitored	Mija, Inc.	For Other Products, Prior Approval is Required

D. Plumbing Products

LOCATION	PRODUCT DESCRIPTION	UNIVERSITY APPROVED VENDOR / MGFR	PROCUREMENT REQUIREMENTS
3.7 B (4)	Water Softening or Conditioning Equipment	GE Osmonics, Pacific Water Inc, Water Specialties, Fluid Treatment Systems	For Other Products / Manufacturers, Prior Approval is Required
3.7 E	Emergency Eye Wash / Emergency Showers	Haws, Bradley, Guardian	For Other Products / Manufacturers, Prior Approval is Required

E. Mechanical Products (General and HVAC)

LOCATION	PRODUCT DESCRIPTION	UNIVERSITY APPROVED VENDOR / MGFR	PROCUREMENT REQUIREMENTS
3.8	Control Valves	Johnson Controls, Inc. Metasys Trane US, Inc. Trane Wasatch Controls Honeywell	No Other Products / Manufacturers Allowed <i>(These Contractors were selected by advertised procurement)</i>
3.8	BTU Meters	Fluxus ADM 7407	For Other Products / Manufacturers, Prior Approval is Required
3.8	Air Compressors	Quincy Compressor FS-Curtis Air Compressors Ingersoll-Rand Company	For Other Products / Manufacturers, Prior Approval is Required
3.8	Vacuum Pumps	Quincy Compressor FS-Curtis Air Compressors Ingersoll-Rand Company	For Other Products / Manufacturers, Prior Approval is Required
3.8	Reciprocating Chillers	Carrier Trane York	For Other Products / Manufacturers, Prior Approval is Required
3.8	Centrifugal Chillers	Carrier Trane York	For Other Products / Manufacturers, Prior Approval is Required
3.8	Pumps, 1-hp or higher	Bell and Gossett Taco Paco Armstrong	For Other Products / Manufacturers, Prior Approval is Required

LOCATION	PRODUCT DESCRIPTION	UNIVERSITY APPROVED VENDOR / MGFR	PROCUREMENT REQUIREMENTS
3.8	Automatic Temperature Control Systems	Johnson Controls, Inc. MSEA Trane US, Inc. Trane Wasatch Controls Honeywell	No Other Products / Manufacturers Allowed (These Contractors were selected by advertised procurement)
3.8 F	Building Automation Systems	Johnson Controls, Inc. Metasys Trane US, Inc. Trane Wasatch Controls Honeywell	No Other Products / Manufacturers Allowed (These Contractors were selected by advertised procurement)
3.8 F	Controllers	Johnson Controls, Inc. Metasys Trane US, Inc. Trane Wasatch Controls Honeywell	No Other Products / Manufacturers Allowed (These Contractors were selected by advertised procurement)

F. High Temperature Water Products

LOCATION	PRODUCT DESCRIPTION	UNIVERSITY APPROVED VENDOR / MGFR	PROCUREMENT REQUIREMENT
3.8 D	Pre-insulated HTW Pipe, Below Grade	Thermacor Process, L.P. Duo Therm "505"	For Other Products / Manufacturers, Prior Approval is Required
3.8 D	Control Valves, HTW Heat Exchangers & Steam Generators	Fisher	For Other Products / Manufacturers, Prior Approval is Required
3.8 D	Controls, HTW Heat Exchanger	Powers 535 Controller	For Other Products / Manufacturers, Prior Approval is Required
3.8 D	Feedwater Controls	McDonnell Miller 150S, Mercoid, Magnetrol	No Other Product / Manufacturers Allowed
3.8 D	Low Water Cut-Out Alarm / High Water Level Cut-Out Alarm	McDonnell Miller 150, Mercoid, Magnetrol	No Other Product / Manufacturers Allowed

G. Laboratory Ventilation Products

LOCATION	PRODUCT DESCRIPTION	UNIVERSITY APPROVED VENDOR / MGFR	PROCUREMENT REQUIREMENT
----------	---------------------	-----------------------------------	-------------------------

LOCATION	PRODUCT DESCRIPTION	UNIVERSITY APPROVED VENDOR / MGFR	PROCUREMENT REQUIREMENT
3.8 N	Hood Manufacturers	Thermo Scientific Hamilton, Kewaunee Scientific Corporation, Labconco Corporation, ALC-Collegeedale, Mott Manufacturing, Ltd.	For Other Products / Manufacturers, Prior Approval is Required
3.8 N	Flow Measuring Device	Phoenix Controls, TSI Incorporated	For Other Products / Manufacturers, Prior Approval is Required
3.8 N	Coatings, Exhaust Fan	Eisenheiss, Heresite	For Other Products / Manufacturers, Prior Approval is Required

H. Communications and Security Wiring Products

LOCATION	PRODUCT DESCRIPTION	UNIVERSITY APPROVED VENDOR / MGFR	PROCUREMENT REQUIREMENT
3.11 B (1)	Cable Seals at Manholes	Virginia KMP Presstite Permagem	Sole Source, No Other Manufacturers Approved (<i>Standardized Maintenance Requirements</i>)
3.11 C (5)	Conduit Entrances	Emerson O.Z. Gedney Bell End Entrances Type TNS	Equal To (No Prior Approval Required)
3.11 F (37)	Communication Device, Elevator Phone Panel	Ramtel Corporation RR833	Sole Source, No Other Products Approved (<i>Standardized Maintenance Requirements</i>)

END OF DOCUMENT