

OS1

Mid-Range High-Resolution Imaging Lidar

FIRMWARE VERSION: 3.1.x

HARDWARE VERSION: REV7

SUMMARY

The mid-range OS1 lidar sensor features 90 m range on a dark 10% target, a 42.4° vertical field of view, and high reliability for the most rugged conditions. The OS1 is designed for all-weather environments and use in industrial automation, autonomous vehicles, mapping, smart infrastructure, and robotics.

HIGHLIGHTS

- Configurable Minimum Range and Return Ordering
- Low Data Rate Profile now available with Dual Returns
- Camera-grade near-infrared and signal data
- Multi-sensor crosstalk suppression
- Ouster Studio for pointcloud evaluation
- Ouster SDK, ROS, and C++ drivers for SW development

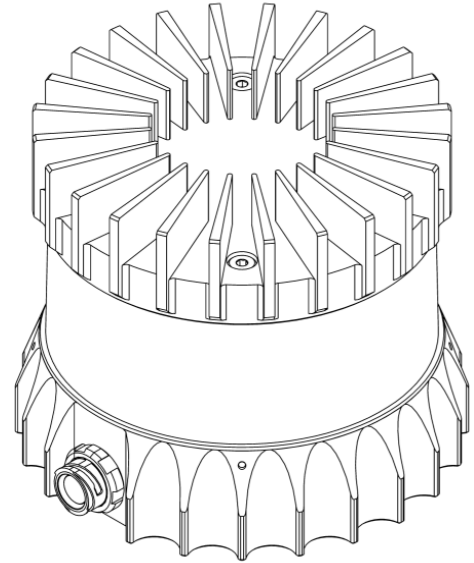

OPTICAL PERFORMANCE

| | |
|--|---|
| Range (80% Lambertian reflectivity, 1024 @ 10 Hz mode) | 170 m @ >90% detection probability, 100 klx sunlight |
| Range (10% Lambertian reflectivity, 1024 @ 10 Hz mode) | 90 m @ >90% detection probability, 100 klx sunlight |
| Minimum Range | 0.0 m (0.3 m optional, and 0.5 m default) |
| Vertical Resolution | 32, 64, or 128 channels |
| Horizontal Resolution | 512, 1024, or 2048 (configurable) |
| Rotation Rate | 10 or 20 Hz (configurable) |
| Field of View | Vertical: 42.4° ± 1.0° (+21.2° to -21.2°) Horizontal: 360° |
| Angular Sampling Accuracy | Vertical: ±0.01° / Horizontal: ±0.01° |
| False Positive Rate | 1/10,000 |
| Range Resolution | 0.1 cm Note: For <i>Low Data Rate Profile</i> the Range Resolution = 0.8 cm |
| # of Returns | up to 2 |
| Return Order | Strongest to Weakest, Farthest to Nearest, and Nearest to Farthest |

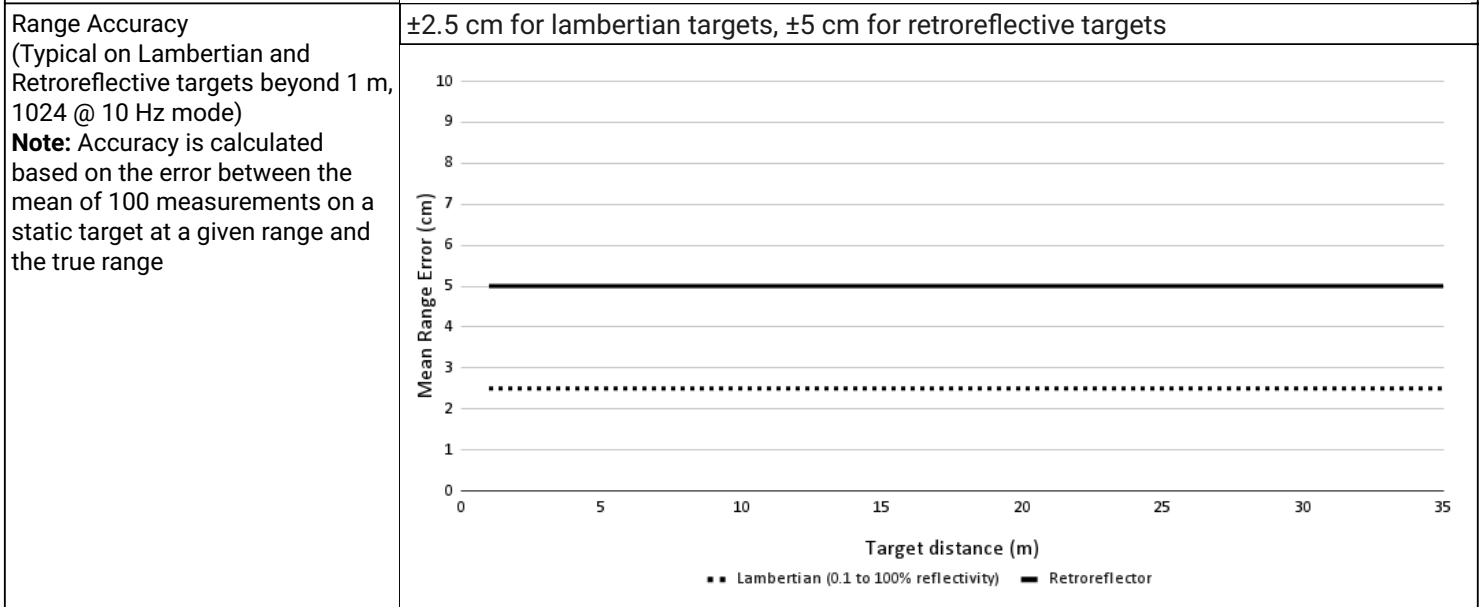
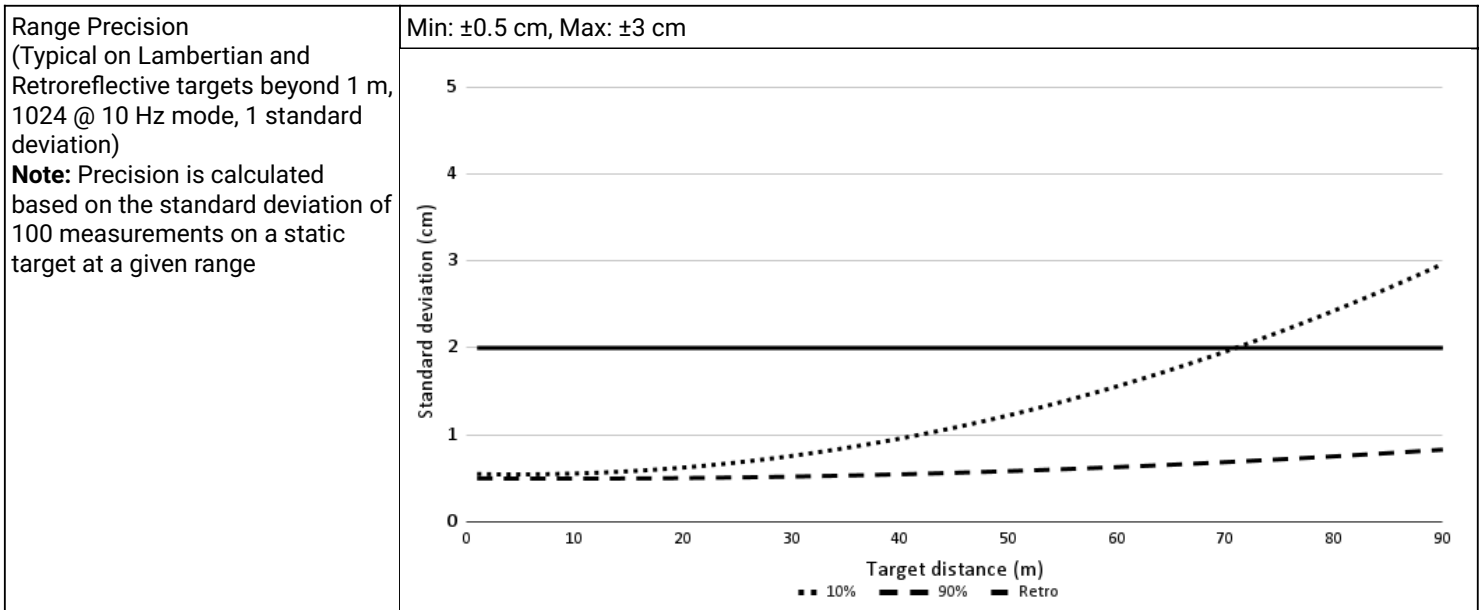

LASER

| | |
|------------------------------|---|
| Laser Product Class | Class 1 eye-safe per IEC/EN 60825-1: 2014 |
| Laser Wavelength | 865 nm |
| Beam Diameter Exiting Sensor | 9.5 mm |
| Beam Divergence | 0.18° (FWHM) |

LIDAR OUTPUT

| | |
|--|--|
| Connection | UDP over gigabit Ethernet |
| Points Per Second | 1,310,720 (32 channel) 2,621,440 (64 channel) 5,242,880 (128 channel) |
| Data Rate (megabits per second) (Low Data Rate Profile, 1 return, 1024 @ 10 Hz mode) | up to 11.83 Mbps (32 channel) up to 22.32 Mbps (64 channel) up to 43.29 Mbps (128 channel) |
| Data Rate (megabits per second) (Low Data Rate Profile, 2 returns, 1024 @ 10 Hz mode) | up to 22.32 Mbps (32 channel) up to 43.29 Mbps (64 channel) up to 85.24 Mbps (128 channel) |

| | |
|---|---|
| Data Rate (megabits per second) (Single Return Profile, 1024 @ 10 Hz mode) | up to 32.81 Mbps (32 channel) up to 64.26 Mbps (64 channel) up to 127.18 Mbps (128 channel) |
| Data Rate (megabits per second) (Dual Return Profile, 1024 @ 10 Hz mode) | up to 43.29 Mbps (32 channel) up to 85.24 Mbps (64 channel) up to 169.12 Mbps (128 channel) |
| Data Per Point | Range, Signal, Reflectivity, Near-infrared, Channel, Azimuth angle, and Timestamp |
| Timestamp Resolution | < 1 μ s |
| Data Latency | < 10 ms |
| Data Integrity | End to End CRC that covers entire data packet |

IMU OUTPUT

| | |
|----------------------|--|
| Connection | UDP over 1000Base-T or 1000Base-T1 |
| Samples Per Second | 100 |
| Data Per Sample | 3 axis gyro, 3 axis accelerometer |
| Timestamp Resolution | < 1 μ s |
| Data Latency | < 10 ms |
| Additional Details | InvenSense IAM-20680HT; datasheet for more details: https://invensense.tdk.com/download-pdf/iam-20680ht-datasheet/ |

CONTROL INTERFACE



| | | |
|----------------------------|---|---|
| Connection | HTTP API | |
| Time Synchronization | Input sources: <ul style="list-style-type: none"> • IEEE1588 Precision Time Protocol (PTP); Accuracy: <1 ms error • gPTP; Accuracy: <1 ms error • NMEA \$GPRMC UART message support • External PPS; Accuracy: <1 ms error • Internal 10 ppm drift clock; Accuracy: <20 ppm error Output sources: <ul style="list-style-type: none"> • Configurable 1 - 60 Hz output pulse | |
| Lidar Operating Modes | <ul style="list-style-type: none"> • x 512 @ 10 Hz or 20 Hz • x 1024 @ 10 Hz or 20 Hz • x 2048 @ 10 Hz | |
| Additional Programmability | <ul style="list-style-type: none"> • Multi-sensor phase lock • Queryable intrinsic calibration information: <ul style="list-style-type: none"> • Beam angles • IMU pose correction matrix | <ul style="list-style-type: none"> • Return ordering • Minimum range • Azimuth masking • Low-power standby mode |

MECHANICAL/ELECTRICAL

| | |
|-------------------|---|
| Power Consumption | 14 - 20 W <ul style="list-style-type: none"> • 16 W nominal • 28 W peak at startup if operating at -40 °C Note: Ouster recommends use of a power supply of no less than 30 W if using in cold conditions |
| Connector | Standard 1000BASE-T or Automotive Standard 1000BASE-T1 |
| Operating Voltage | 9.5 V - 51 V <ul style="list-style-type: none"> • Suitable for 12 VDC to 24 VDC nominal systems • Not suitable for 48 V nominal battery based systems • Under-voltage WARNING level alert occurs at 9.5 VDC at the connector • Under-voltage ERROR level alert occurs at 9.0 VDC at the connector • Below 9.0 VDC at connector, sensor may shutdown • Over-voltage conditions/alarms occur at 51 VDC at the connector • Over-voltage lockout onset at 58 VDC (\pm1 V) at the connector • Over-voltage lockout release at 55 VDC (\pm1 V) at the connector |

| | |
|------------|--|
| Dimensions | Diameter: 87 mm (3.42 in) Height: • Without cap: 58.35 mm (2.3 in) • With thermal cap: 74.2 mm (2.9 in) |
| Weight | Without cap: 410 g (14.5 oz) With radial cap: 482 g (17.0 oz) With halo cap: 502 g (17.7 oz) |
| Mounting | Bottom: 4x M3 screws, 2x locating 2 mm pin holes Top: 4x M3 screws, 4x locating 2 mm pin holes, 1x M6 screw |

OPERATIONAL

| | |
|-----------------------|---|
| Operating Temperature | -40 °C to +60 °C (with mount) Between +53 °C and +60 °C, sensor automatically reduces range (max 20% range reduction) |
| Storage Temperature | -40 °C to +105 °C |
| Ingress Protection | IP68 (1 m submersion for 1 hour, with I/O cable attached) IP69K (with I/O cable attached) |
| Shock | IEC 60068-2-27 (Amplitude: 100 g, Shape: 11 ms half-sine, 3 shocks x 6 directions) |
| Vibration | IEC 60068-2-64 (Amplitude: 3 G-rms, Shape: 10 - 1000 Hz, Mounting: sprung masses, 3 axes w/ 8 hr duration each) |
| Compliance | <p>For US</p> <p>Laser Safety:</p> <ul style="list-style-type: none"> • EN/IEC 60825-1:2014 Class 1 eye safe • FDA US 21CFR1040 Notice 56 Class 1 <p>Product Safety:</p> <ul style="list-style-type: none"> • UL 62368-1 • UL 60950-22 (outdoor use) • CSA-C22.2 No. 62368-1-19 • CSA-C22.2 No. 60950-22-07 (outdoor use) <p>EMC: FCC 47CFR Part 15, Subpart B, Class A</p> <p>For EU</p> <p>Laser Safety: EN/IEC 60825-1:2014 Class 1 eye safe</p> <p>Product Safety: EN/IEC 62368-1</p> <p>EMC:</p> <ul style="list-style-type: none"> • EN 55032:2012/AC 2013; CISPR 32:2015 • EN 55024:2010; CISPR 24:2010 • EN 61000-3-2:2014 • EN 61000-3-3:2013 <p style="text-align: center;">    </p> |

Note: Ouster UK (Ltd): 125 Princes Street, Edinburgh EH2 4AD, Scotland, United Kingdom
Contact: Neil Calder, Phone Number: +44(0).131.563.9078

ACCESSORIES

| | |
|---------------|--|
| Interface Box | Polycarb/FR4, 100 g, 75 mm x 50 mm x 25 mm (LxWxH), 2 m CAT6 cable, 24 V power adapter, 5 m sensor cable |
| Mount | Aluminum, 530 g, 110 mm x 110 mm x 20.5 mm (LxWxH), 4 x M8 thru holes |

SOFTWARE

| | |
|----------------|----------------------|
| Sample Drivers | Ouster SDK, ROS, C++ |
| Visualizer | Ouster Studio |

EXTERIOR DIMENSIONS

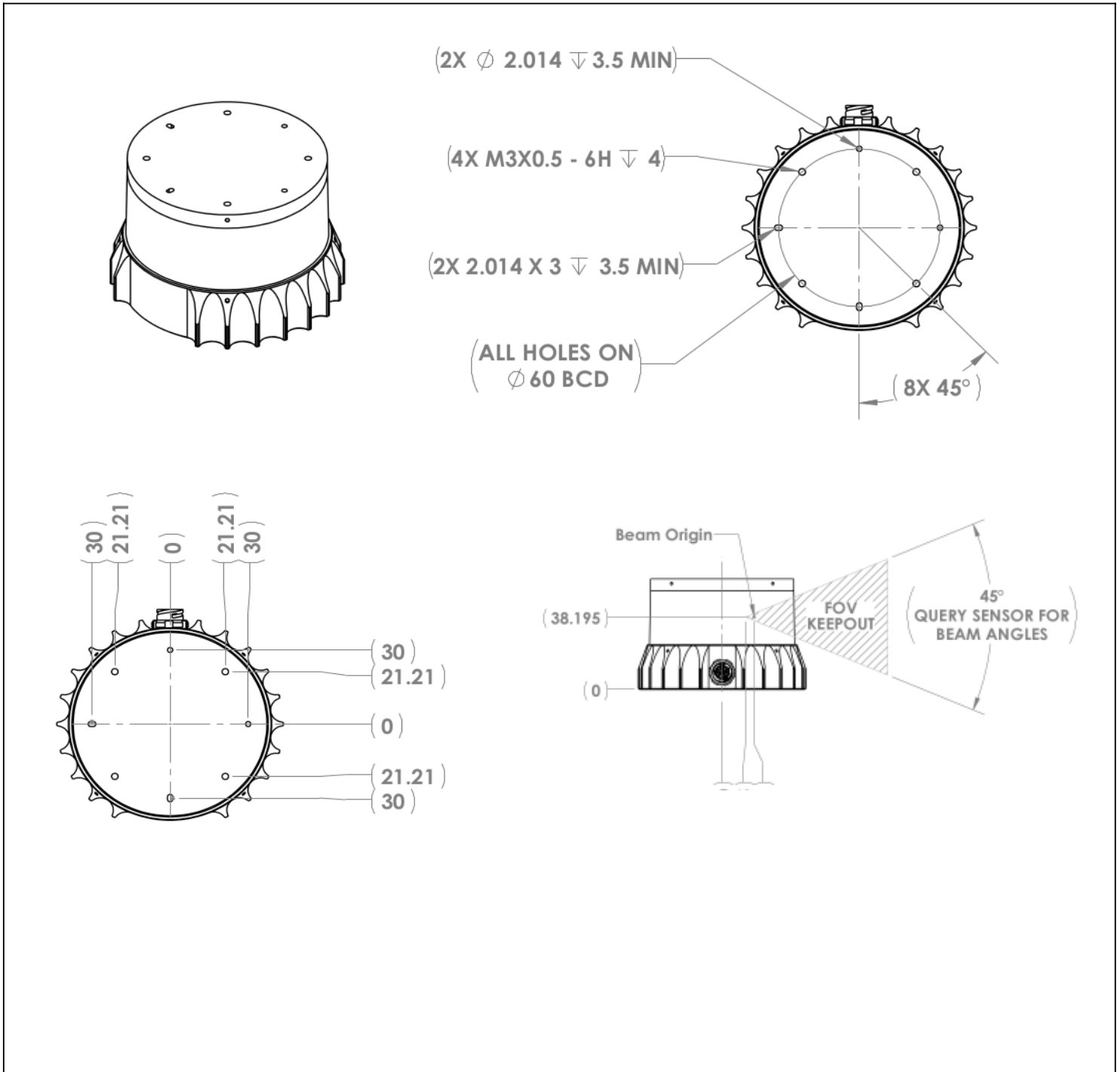

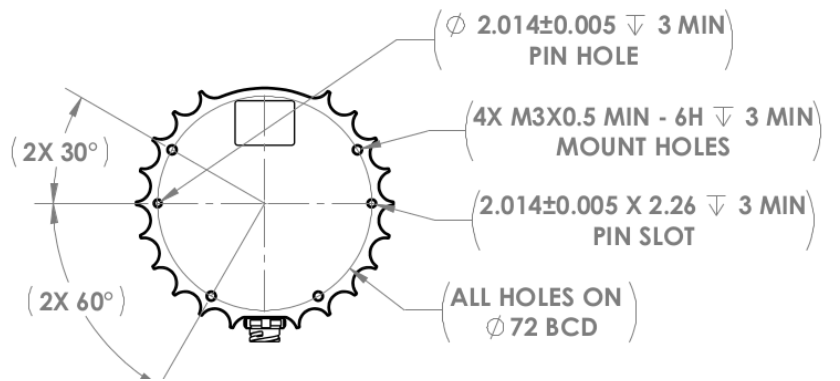
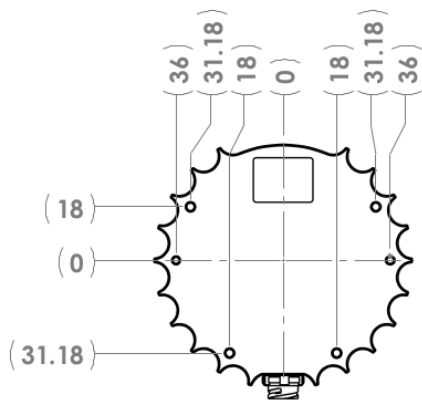
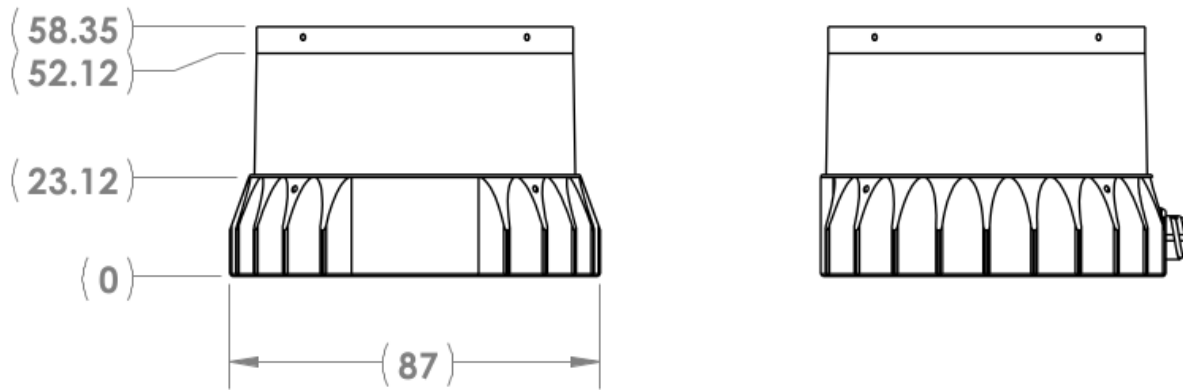

*Specifications are subject to change without notice.

WWW.OSTER.COM

REV: 06/2024 • © 2024 Ouster, Inc. • All rights reserved