

Raspberry Pi 3-pin Debug Connector Specification

Introduction

Raspberry Pi is standardising on using a small, keyed, 3-pin connector which can be used for either UART or 2-wire serial debug interfaces. Future Raspberry Pi devices with dedicated serial debug or UART interfaces will, where possible, use this connector and follow this specification.

The oldest and most universal ‘debug’ port is a simple 16550-style UART. A UART requires 2 unidirectional pins, one to transmit data from the target to the host (TX) and one for the other direction (RX).

The 3-pin serial debug connector interface is designed to work with a single unidirectional clock pin and a bidirectional data I/O pin. This arrangement can support ARM’s Serial Wire Debug (SWD) or things like cJTAG, for example.

This document uses the words **target** and **host** to describe the debug target (e.g., a Raspberry Pi Pico) and debug host (the debug dongle, e.g., RP2040 running debugprobe) respectively.

***Note when talking about UART TX and RX, we are talking about these pins from the target perspective. E.g., if the target is a BCM2711 SoC, then RX means the signal driving into the SoC and TX driving out from the SoC.**

Pinout

Each of the interfaces needs 2 pins and a ground, so a keyed 3-pin connector can be used for both:

Pin Number	UART Signal	Serial Debug Signal
1	RX	SC (serial clock)
2	GND	GND
3	TX	SD (bidirectional serial data)

We specify the pinout such that the unidirectional SC (which is driven into the debug target) is on the same pin as the UART RX signal that is in the same direction (this avoids contention as we are using the same connector for both UART and serial debug so mis-plugging is possible).

We specify that SD and UART TX are on the same pin. Using the specified pinout If you plug a UART into a serial debug interface it is ‘safe’ and no contention will occur. If you plug a serial debug interface into a UART, contention is possible on the TX/SD pin but current will be limited by the termination resistors.



We further specify ‘source termination’ resistors on both pins at both ends of the link:

- 100 Ohm resistor on the SC/TX and SD/RX IC pins at the host
- 100 Ohm resistors on the SC/RX and SD/TX IC pins at the target

These resistors *must* be placed very close to the IC pins of the debug host and the target device so the serial combination of 200R only has to ‘drive’ the pin capacitance and shortest possible PCB trace capacitance.

The resistors provide some slew limiting (better for signal integrity and EMC), short-circuit and ESD current limiting. Note that the 100R resistors at the target are not strictly required but highly recommended unless the platform is very low cost and/or space constrained.

The series resistors will limit the maximum speed of the interface, however over a few 10s of CM of cable and PCB ~30MHz performance should still be achievable.

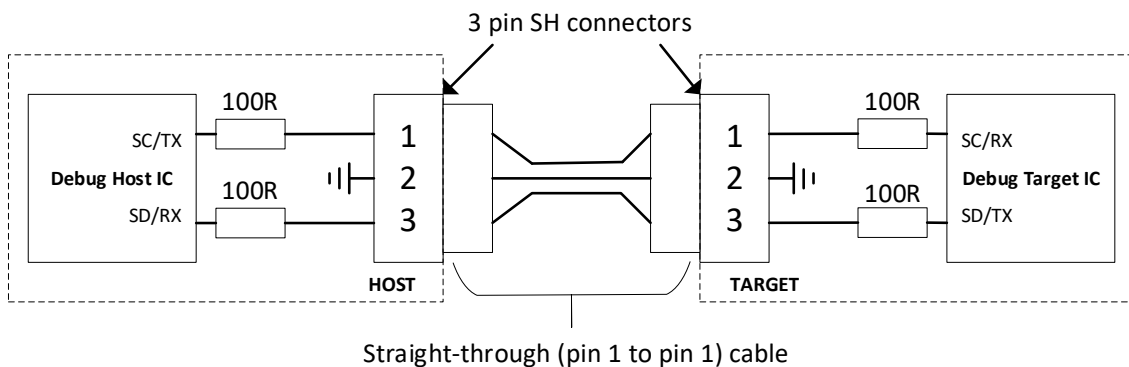

Voltages

We specify that the interface on the debug host should operate at 3.3V (+/- 10%). It is recommended that targets use 3.3V I/O where possible but they can operate at IO voltages of between 1.8 to 3.3V (+/- 10%) as long as they follow the rules below.

Hosts and targets using these interfaces **MUST** have 3.3V **failsafe** pads. (Failsafe means that even if the host or debug target is unpowered, the pins will survive 3.3V+10% being applied to them continuously and will not draw any current).

We allow a debug target to work at lower voltages, say 2.5V or 1.8V, but in this case, as before, the pins used **MUST** still be both 3.3V tolerant and failsafe to 3.3V (plus 10%). **Note that the RP2040**



microcontroller pins satisfy the above tolerance and failsafe requirements when being used at any voltage from 1.8V to 3.3V.

We further specify that debug hosts MUST be able to work correctly with IO voltages down to 1.8V on their TX/SD pin (pin 3). This allows targets using 1.8V IO (which, as per the previous paragraph still must have 3.3V tolerant and failsafe pins) to interface to the debug host reliably.

Connector

We specify the connector to be a 1.0mm pitch 3-pin JST 'SH' connector either BM03B-SRSS-TB (top entry) or SM03B-SRSS-TB (side entry) types, or compatible alternatives.

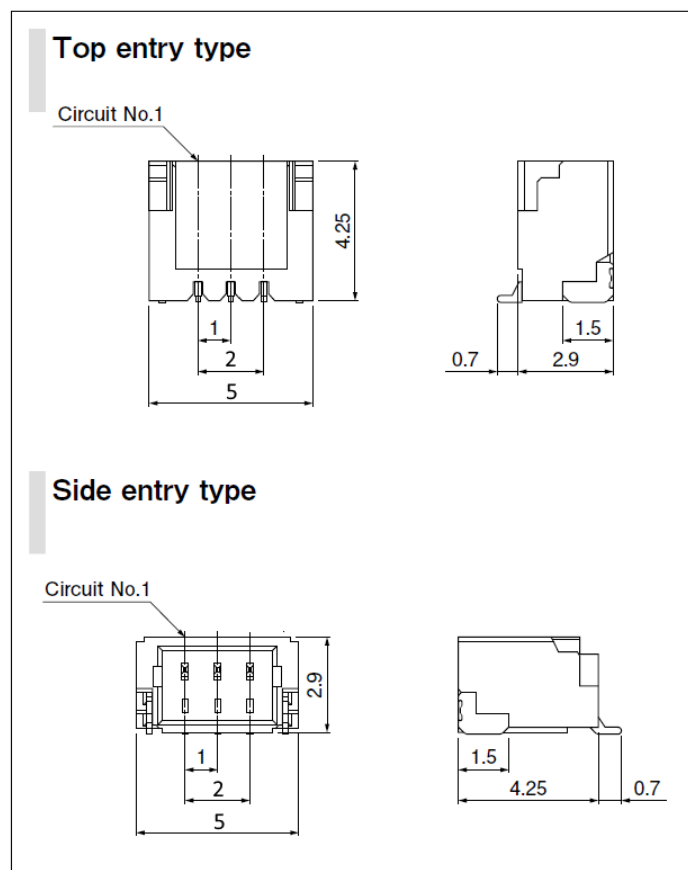

The following PCB footprints show the pin numbering for both top and side entry types and signal direction from the target perspective. For clarity, the fact that we are showing UART on a side entry type and serial debug on the top entry type is just for example – either type can use either interface:



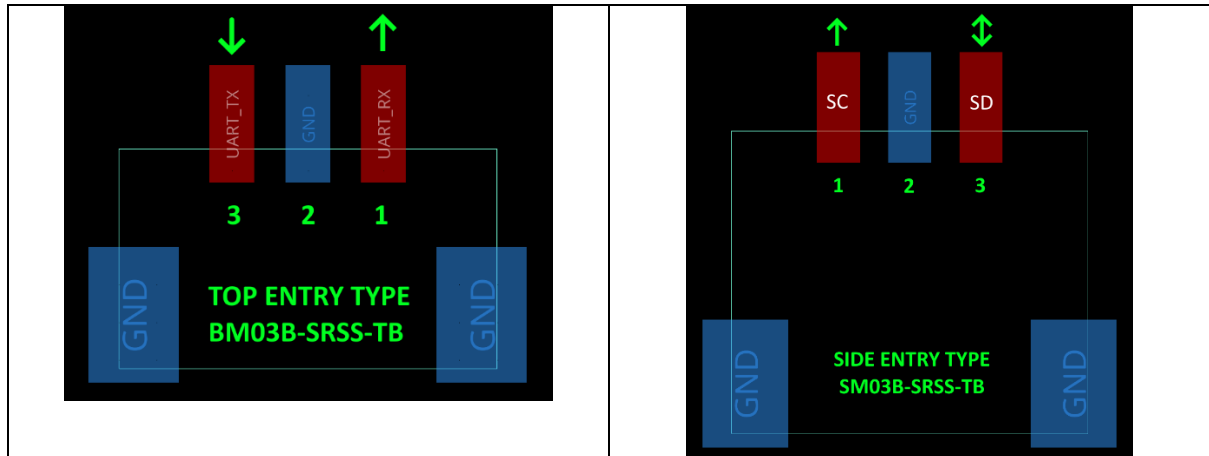

Further Requirements

Products should, where possible, clearly mark what interface the 3-pin connector is for, to avoid users plugging in the wrong interface. If it is not possible to clearly mark the connector (e.g. if the PCB is too small and/or dense) then it should be clearly marked in the product documentation.

Mark 'UART' next to the connector for a UART.

Mark the type of 2-wire debug interface next to the connector for serial debug (e.g. 'SWD' or 'cJTAG') or alternatively mark as 'DBG', 'DEBUG' or 'DEBUG'.

