



**Deep Space Network**

# 209

## Open-Loop Radio Science

---

Document Owner:

Approved by:

Signature provided                      01/16/2019  
Alina Bedrossian                      Date  
Science System Engineer

Signature provided                      01/15/2019  
Timothy Pham                      Date  
Communications Systems Chief  
Engineer

Prepared By

Released by:

Signature provided                      01/10/2019  
Stephen Rogstad                      Date  
OLR Software CDE

Signature provided                      01/17/2019  
Christine Chang                      Date  
DSN Document Release Authority

DSN No. **810-005, 209, Rev. D**  
Issue Date: February 14, 2019  
JPL D-19379; URS CL#19-0898

---

**Jet Propulsion Laboratory**  
California Institute of Technology

*Users must ensure that they are using the current version in DSN Telecommunications Link Design Handbook website:*  
<https://deepspace.jpl.nasa.gov/dsndocs/810-005/>

© <2019> California Institute of Technology.  
U.S. Government sponsorship acknowledged.

## Review Acknowledgment

*By signing below, the signatories acknowledge that they have reviewed this document and provided comments, if any, to the signatories on the Cover Page.*

<u>Signature provided</u>	<u>12/20/2018</u>
Jeff Berner	Date
DSN Project Chief Engineer	

<u>Signature provided</u>	<u>01/04/2019</u>
Sue Finley	Date
OLR Subsystem Engineer	

***Document Change Log***

<b>Rev</b>	<b>Issue Date</b>	<b>Prepared By</b>	<b>Affected Sections or pages</b>	<b>Change Summary</b>
Initial	1/15/2001	R. Sniffin	All	All
A	6/1/2010	A. Kwok	All	Added Wideband VLBI Science Receiver (WVSR) and VLBI Science Receiver (VSR). Eliminated the Rev. E designation for the document series.
B	02/09/2015	A. Bedrossian S. Finley D. Shin	Section 2	Add DSS-35
C	11/17/2016	A. Bedrossian D. Shin	Section 2	Add DSS-36 Remove DSS-45 Updated Figures Some minor editorial corrections throughout the document
D	02/14/2019	S. Rogstad A. Bedrossian	All	Updates for OLR Delivery Remove DSS-15

## *Contents*

<b><u>Paragraph</u></b>	<b><u>Page</u></b>
1 Introduction.....	6
1.1 Purpose.....	6
1.2 Scope.....	6
2 General Information.....	6
2.1 Functions.....	6
2.2 Hardware Configuration .....	7
2.3 OLR Signal Processing.....	8
2.4 Available IF Inputs .....	11
2.5 OLR Signal Detection.....	11
2.6 OLR Operation.....	12
2.7 Data Delivery .....	12
2.7.1 Ancillary Data.....	12
2.8 Performance .....	13
2.8.1 Frequency Stability .....	14
2.8.2 Phase Noise.....	15
2.8.3 Amplitude Stability.....	15

## *Illustrations*

<b><u>Figure</u></b>	<b><u>Page</u></b>
Figure 1. OLR Signal Flow.....	7
Figure 2. Relationships between Processing Bands for OLR.....	9

**Tables**

<b><u>Table</u></b>	<b><u>Page</u></b>
Table 1 - Sample of OLR Supported Bandwidths .....	10
Table 2 - Available IF Inputs at each complex .....	11
Table 3. Open Loop Receiver Characteristics .....	13
Table 4. Two-Way (Uplink and Downlink) Allan Deviation Estimates .....	15
Table 5. Uplink and Downlink Phase Noise Estimates .....	15

## **1 Introduction**

### **1.1 Purpose**

This module describes the capabilities and performance of the Deep Space Network (DSN) open-loop receiving equipment used for supporting radio science (RS) experiments. Radio science experiments formerly used the Radio Science Receiver (RSR), VLBI Science Receiver (VSR) and Wideband VLBI Science Receiver (WVSR). These three assemblies have been replaced by the Open Loop Receiver (OLR) Subsystem.

### **1.2 Scope**

This module discusses the open-loop radio science receiving equipment functions, architecture, operation, and performance. Although some RS experiments require uplink support and closed-loop Doppler and ranging data, this module only describes the open-loop recording capability that is used during radio science experiments. Open-loop recording is carried out by the OLR Subsystem. Details of the closed-loop Doppler tracking system can be found in module 202, Doppler Tracking. Details of the uplink functions can be found in the 70-m, the 34-m High Efficiency (HEF), and the 34-m Beam Waveguide (BWG) telecommunications interface modules 101, 103, and 104 respectively.

## **2 General Information**

Radio science experiments involve measurements of small changes in the phase, frequency, amplitude, and polarization of the radio signal propagating from an interplanetary spacecraft to an Earth receiving station. By properly analyzing these data, investigators can infer characteristic properties of the atmosphere, ionosphere, and planetary rings of planets and satellites, measure gravitational fields and ephemerides of planets, monitor the solar plasma and magnetic fields activities, and test aspects of the theory of general relativity. Details of Radio Science System applications may be found in the JPL Publication 80-93, Rev. 1, written by S.W. Asmar and N.A. Renzetti, titled: *The Deep Space Network as an Instrument for Radio Science Research*. (<https://ntrs.nasa.gov/search.jsp?R=19950015039>).

### **2.1 Functions**

The functions of the DSN with respect to conducting radio science experiments can be summarized as follows:

- Providing uplink carrier signals to the spacecraft with a pure spectrum, including low phase noise and stable frequency.
- Acquisition, down conversion, digitization, and recording of the downlink carrier with minimal degradation to its frequency, phase, and amplitude stability.

- Assuring that the expected signals are being acquired and recorded.

## 2.2 Hardware Configuration

All radio science experiments require use of the antenna, microwave, antenna-mounted receiving equipment, and frequency and timing equipment at the stations, as well as the receivers in the signal processing center (SPC). They also require the Ground Communications Network (GCN) to deliver data from the stations to users at JPL, where experiments are monitored. A block diagram of the open-loop receiving capability is shown in Figure 1.

The receiving equipment on each DSN antenna produces one or more intermediate frequency (IF) signals with S-band producing an IF in the range 200 to 300 MHz; X-band 100-500 MHz and Ka-band 100-600 MHz. These IF signals are routed to an IF Gain Control (IGC) assembly and then digitized by the IF Digitizer (IFD). The IF digitizer channelizes the IF band and sends digital packets through the Digital IF Switch (DIS) to the OLR receivers.

Each of the 8 station OLRs can support up to 16 different IF inputs and each of the 16 possible configurable recording channels (see table Table 1) can have a different BW, bit depth and static/predicted frequency configuration. . However, limitations to this should be noted. An OLR should not be shared between users during a track, due to concerns about interference and having to divide up the available 16 channels. Users usually need multiple channels to record a given IF. Also, the total aggregate input bit rate of each OLR cannot exceed the 10Gbps Ethernet pipe.

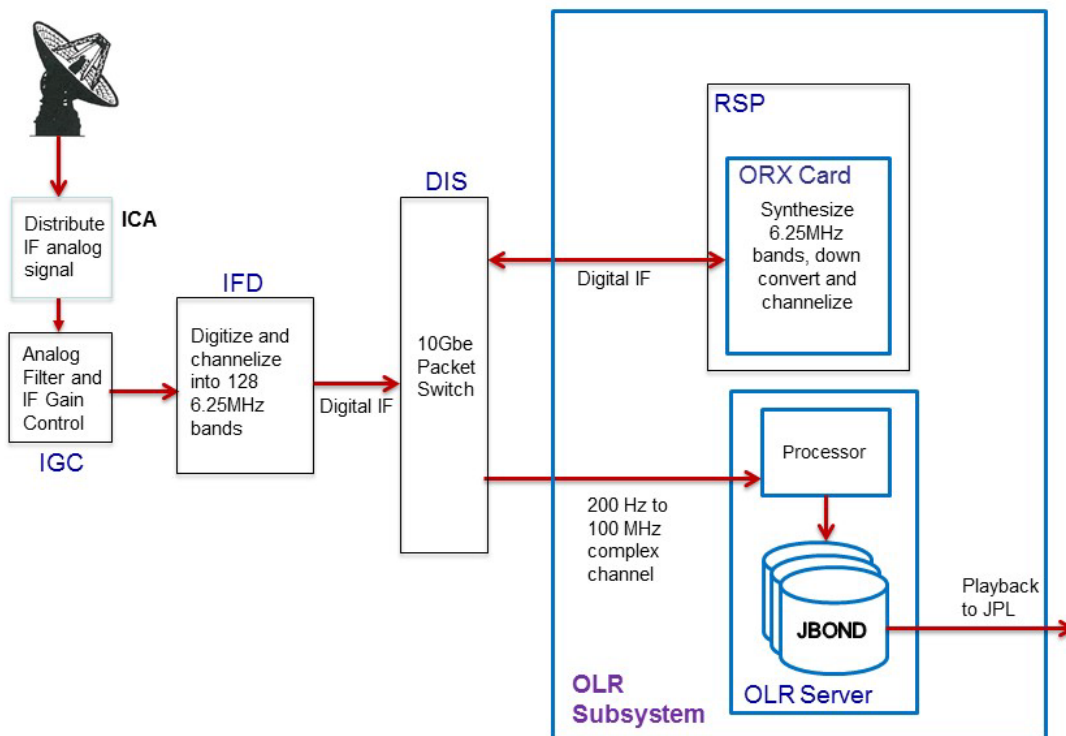

Figure 1. OLR Signal Flow

### **2.3            *OLR Signal Processing***

The IF signal is sampled in the IF Digitizer (IFD) where it is digitized and downconverted to 0-800MHz complex with a center frequency of 400MHz. However, the IF Gain Control (IGC) assembly filters the signal before entering the IFD to limit its bandwidth to the range of 86–607 MHz. This corresponds to a received frequency range of 2086-2607MHz at S-band, 8186-8707MHz at X-band, and 31786-32307MHz at Ka-band. However, the actual effective received frequency range will depend on the filter characteristics of the equipment on the selected antenna and may be narrower. Figure 2 illustrates the processing bandwidth through the OLR Subsystem.

The filtered IF signal is digitized at 3200 Ms/s with a 12-bit resolution, then downconverted to 0-800MHz complex with a center frequency of 400MHz and an equivalent resolution of 14 bits.

The recording channel filters are specified by their bandwidths, the desired resolution (bits/sample) and an offset from the predicted sky frequency predict file. This frequency predicts file is created by the DSN network support function and contains the spacecraft frequency altered by spacecraft trajectory and Earth-rotation. Table 1 lists a sample of the supported OLR filter bandwidths and resolutions. The OLR provides many other bandwidths and bit rates, however this table shows only those typically required by RS users. For a more exhaustive list of supported OLR channel bandwidths, see Section 3.2 of 820-013 0222-Science.



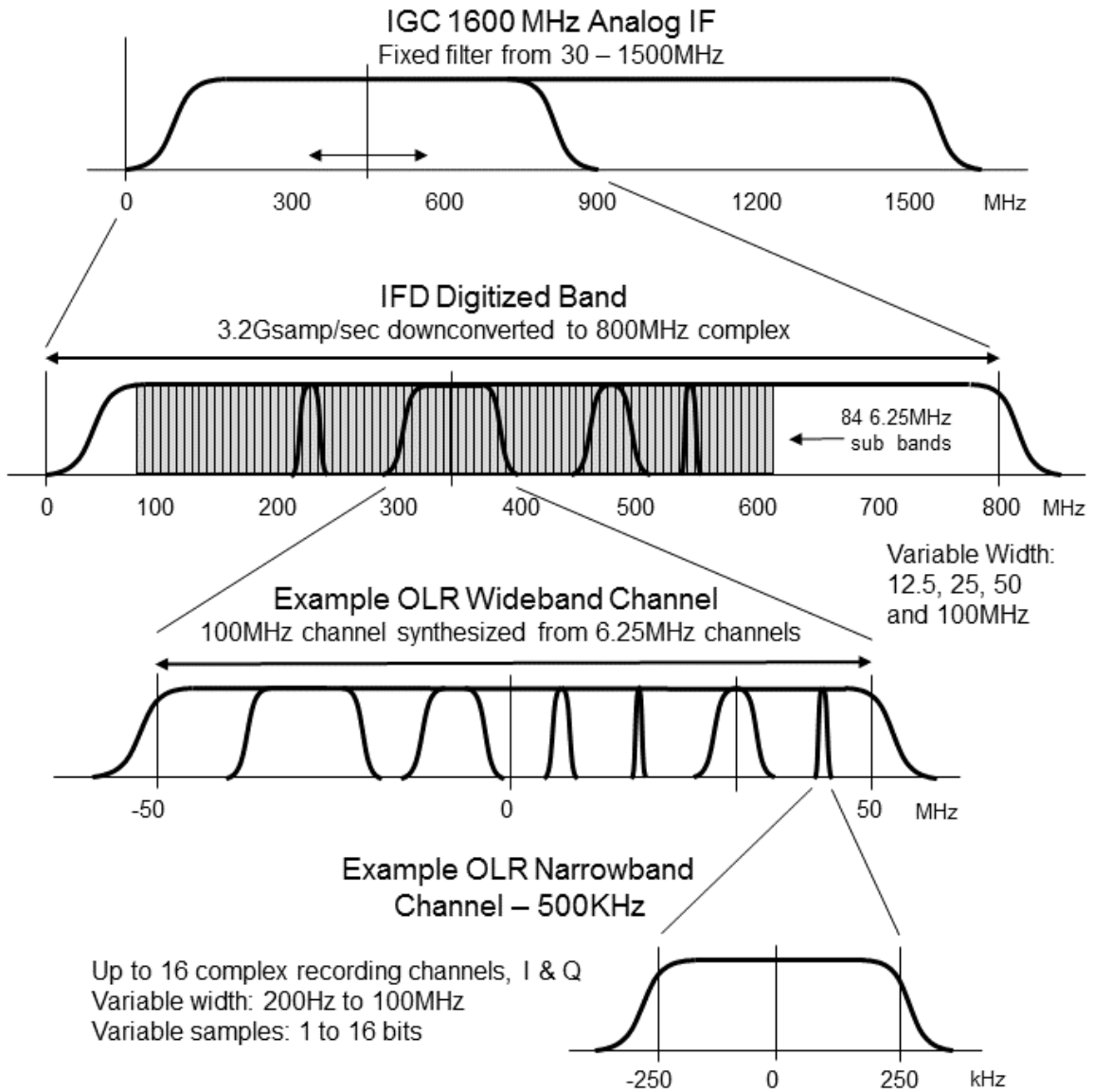

Figure 2. Relationships between Processing Bands for OLR

Table 1 - Sample of OLR Supported Bandwidths

<b>Category</b>	<b>Bandwidth</b>	<b>Resolution (b/sample)</b>	<b>Upper Data Rate (b/s)</b>
Narrowband	200 Hz	8,16	6400
	250 Hz	8,16	8000
	500 Hz	8,16	16000
	1 kHz	8,16	32,000
	2 kHz	8,16	64,000
	4 kHz	8,16	128,000
	8 kHz	8,16	256,000
	16 kHz	8,16	512,000
	25 kHz	8,16	800,000
	50 kHz	8,16	1,600,000
	80 kHz	8,16	2,560,000
	100 kHz	8,16	3,200,000
	250 kHz	8,16	8,000,000
	500 kHz	8,16	16,000,000
	Wideband	1 MHz	8,16
2 MHz		8,16	64,000,000
1 MHz		2,4	8,000,000
2 MHz		2,4	16,000,000
4 MHz		2,4	32,000,000
8 MHz		2	32,000,000
16 MHz		2	64,000,000
32 MHz		2	128,000,000
40 MHz		2	160,000,000
50 MHz		2	200,000,000

## 2.4 Available IF Inputs

Using a single client on a server, the OLR is capable of tracking and recording channels from up to 16 IF inputs at one time. These IF inputs available at each of the 3 DSN complexes are shown in Table 2.

## 2.5 OLR Signal Detection

The OLR does not have a mechanism to align its passband to (establish lock with, or track) the received signal. Instead, it relies on predicts to position its passband. This creates a risk that a predict error might result in the wrong portion of the received spectrum being processed. To assist in recognizing this, the OLR analyzes the data in each channel and provides a detected signal indication on the main display for that channel for diagnostic purposes only.

In addition to the detected signal indication, the OLR provides a frequency-domain representation of the bandpass being recorded in each channel using a Fast-Fourier Transform (FFT). Characteristics of the FFT such as number of points, averaging, and update rate are under user control.

Table 2 - Available IF Inputs at each complex

Goldstone IF Inputs	Madrid IF Inputs	Canberra IF Inputs
14_S1	63_S1	43_S1
14_S2	63_S2	43_S2
14_X1	63_X1	43_X1
14_X2	63_X2	43_X2
24_S1	65_S1	34_S1
24_X1	65_X1	34_X1
		34_K1
25_X1	54_S1	34_K2*
25_X2	54_X1	
25_K1	54_K1	35_X1
25_K2*	54_K2*	35_X2
		35_K1
26_S1	55_X1	35_K2*
26_X1	55_X2	
26_X2	55_K1	36_S1
26_K1	55_K2*	36_X1
26_K2*		36_X2
	DDA1	36_K1
DDA1	SGA1	36_K2
SGA1	SGA2	
SGA2		DDA1
		SGA1
		SGA2

\*Will be available July 2019, after installation of the DTT cables.

## **2.6            *OLR Operation***

Of the 8 OLRs per station, six operate in a connection (link-assigned) mode and two in a stand-alone mode. In the connection mode, the Network Monitor and Control (NMC) function receives monitor data from the OLR for displays at the NMC and provides a workstation from which the OLR can be operated. OLRs that are not assigned to a link are operated in a stand-alone mode without interference to any activities in process at the complex. Monitor data is not forwarded to the NMC by OLRs operating in the stand-alone mode.

The OLR employs a client-server architecture where each one acts as a server capable of accepting multiple connections from users operating the appropriate receiver client software at any time. In the link-assigned mode, one of these clients is the NMC workstation. The OLR does not recognize any remote client as being superior to the others so it is up to the user to assign responsibility for control to one client with the other clients operating in a passive mode. NMC clients, on the other hand, have priority over remote clients and will terminate remote clients when brought up in a connection. Users who want to remotely monitor link-assigned OLR activities should bring up a remote client after it is put in the link.

All functions of the OLR may be performed from the OLR client in real time. Of special interest to the RS experimenter is the ability to adjust the predicted frequency profile, to slew the individual channel frequencies, to adjust FFT parameters, and to enable or disable recording for each channel.

## **2.7            *Data Delivery***

When recording is enabled, baseband samples and ancillary information, discussed below, are formatted into a file of one-second data records and stored on an OLR server for delivery via network playback to JPL or other users. A separate data file is created for each channel. Data delivery is via file transfer using Secure Shell (SSH) protocol. Data also may be obtained via Secure File Transfer Protocol (SFTP). The OLR is capable of playing data back in legacy 0159-Science format as well as 0222-Science format.

### **2.7.1        *Ancillary Data***

The following ancillary data are included as a header in each data record. A detailed description of the data is contained in DSN Document 820-013, module 0159-Science. The users will need to include the last two items in the filename for each channel to properly identify the supporting station, tracking pass, and spacecraft.

- Data record version
- Receiver configuration
- Channel identification
- Time tag for first sample in block
- Station and pass identification

- Spacecraft identification

## 2.8 Performance

The principal characteristics of the OLR are summarized in Table 3. In addition, radio science experiments are influenced by the overall stability of equipment at the stations. The following sections provide information on performance characterization in terms of frequency stability, phase noise, and amplitude stability for the ground stations.

Table 3. Open Loop Receiver Characteristics

Parameter	Value	Remarks
Frequency Ranges Covered		
At OLR Input (MHz)	100 - 600	
Referenced to S-band (MHz)	2,086 – 2,607	S-band downlink allocation is 2,200–2,290 MHz for near Earth application and 2,290–2,300 MHz for deep space applications
Referenced to X-band (MHz)	8,186 – 8,707	X-band downlink allocation is 8,400–8,450 MHz for deep space application and 8,450–8,500 MHz for near Earth applications
Referenced to Ka-band (MHz)	31,786 – 32,307	Ka-band downlink allocation is 31,800–32,300 MHz for deep space applications.
IF Attenuation		Applied by IGC
Range (dB)	0 – 31.75	
Resolution (dB)	0.25	
Doppler Compensation		
Maximum Doppler Shift (km/s)	30	At all downlink frequencies
Maximum Doppler Rate (m/s <sup>2</sup> )	17	At all downlink frequencies
Maximum Doppler Acceleration (m/s <sup>3</sup> )	0.3	At all downlink frequencies
Maximum Tuning Error (Hz)	0.5	At all downlink frequencies
Maximum Bitrate (Mb/sec)	512	Maximum recordable data rate per OLR with no performance degradation, assuming all 8 station OLRs are running at this rate.

Table 3. OLR Characteristics (Continued)

Parameter	Value	Remarks
Baseband Resolution (MHz)	1	
Configurable Recording Channels	16	Available on each of the 8 OLRs
Narrow Channel Tuning		
Tuning (MHz)	±50	
Resolution (Hz)	<1	
Recording Bandwidths	200 Hz – 50 MHz	
Resolutions (bits/sample)	1-16*	
Time Tagging		
Resolution (s)	1	Data is time tagged once per second
Accuracy (µs)	1	With respect to station clock
Signal Detection Display		1 for each subchannel being recorded
Number of points in FFT	128 – 131,072	Default is 1024
Spectra Averaging	1 – 1000	Default is 10
FFT Interval (s)	1 – 10,000	Default is 10

\*The 16 bits/sample will be available July 2019

### 2.8.1 *Frequency Stability*

DSN stations are designed to meet radio science requirements for stability. Frequency stability of the ground station is characterized by means of Allan deviation. RS System Performance Testing (SPT) has been conducted with the exciter, transmitter, the low noise amplifier (LNA), and the OLR receiving equipment. In this test configuration, an uplink signal generated by the exciter is frequency shifted via the test translator to a downlink frequency. The downlink signal is injected at the front-end of the LNA and passed through the RF-IF downconverter IGC and IFD which provides the IF signal to the OLR. SPT excludes instability in the frequency and timing equipment and the mechanical vibrations of the antenna. This is because frequency and timing instability is cancelled out, while the mechanical vibrations of the antenna are not included in the test configuration. Measurements of these items can be obtained via other means, making it possible to provide an estimate of the overall frequency stability for the stations.

Repeated SPT measurements have provided the basis of estimating the Allan deviation over a specified integration time for the ground station. Table 4 shows the 2-way Allan deviation numbers that any DSN ground station can achieve. These estimates include all elements in the ground station that constitutes the measurement path through which the OLR data are obtained. The values shown are meant to be the upper bound for performance (i.e., the not-to-exceed numbers). The measurements and analysis have accounted for the various station types (HEF, BWG, 70m), the different frequency band combinations (S, X, and Ka), and various system configurations.

**2.8.2 Phase Noise**

Phase stability (Spectral Purity) testing characterizes stability over very short integration times. The region of the frequency band where phase noise measurements are performed can be as far as 10 kHz off the carrier frequency. Such measurements are reported in dB relative to the carrier (dBc), in a 1 Hz band at a specified distance from the carrier.

Phase noise data have also been captured as part of the SPT measurements. Table 5 shows the not-to-exceed phase noise levels for the different frequency bands, at specified offsets. As is the case with frequency stability testing, these numbers have been obtained through many repeated SPT measurements. They represent what the DSN can achieve under normal operation conditions.

**2.8.3 Amplitude Stability**

Amplitude stability tests measure the amplitude fluctuations produced by the open-loop receiving system relative to a constant (mean) amplitude input signal. The amplitude stability performance is specified in terms of a threshold on the amplitude fluctuations relative to the mean amplitude, and the corresponding probability that such fluctuations will not exceed such a threshold. Analyses with the collected data indicate that the 1-sigma number (67% of the time) of the amplitude stability at a given DSN station over a 30-minute observation at any frequency bands is less than 0.2 dB. This number includes the gain variation due to antenna pointing errors.

Table 4. Two-Way (Uplink and Downlink) Allan Deviation Estimates

Averaging Time, s	Allan Deviation			
	1	10	100	1000
Station				
34-m HEF / 34-m BWG / 70-m	$7.0 \times 10^{-13}$	$2.0 \times 10^{-13}$	$3.0 \times 10^{-14}$	$5.0 \times 10^{-15}$

Table 5. Uplink and Downlink Phase Noise Estimates

Offset from Carrier, Hz	Phase Noise, dBc		
	1	10	100
Frequency Band			
S-band (Uplink or Downlink)	-63	-69	-70
X-band (Uplink or Downlink)	-63	-69	-70
Ka-band (Uplink or Downlink)	-50	-55	-57