

# COOPERATIVE DEVELOPMENT OF L75 LOX ETHANOL ENGINE: CURRENT STATUS WITH FOCUS ON CAPACITIVE CHAMBER TESTING

MARRIOTT PARK HOTEL, ROME, ITALY / 2–6 MAY 2016

**Daniel Soares de Almeida<sup>(1)</sup>, Cristiane Maria de Moraes Pagliuco<sup>(1)</sup>, Bernardo Reis Dreyer de Souza<sup>(1)</sup>, Holger Burkhardt<sup>(2)</sup>, Claus Lippert<sup>(2)</sup>, Axel Preuß<sup>(3)</sup>, Günter Langel<sup>(4)</sup>**

<sup>(1)</sup> IAE, Institute of Aeronautics and Space, Praça Mal. Eduardo Gomes, 50, São José dos Campos, Brazil, Email: danieldsa@iae.cta.br, cristianecmmp@iae.cta.br, bernardobrds@iae.cta.br

<sup>(2)</sup> DLR, German Aerospace Center, Königswinterer Str. 522-524, 53225 Bonn, Germany, Email: holger.burkhardt@dlr.de, claus.lippert@dlr.de

<sup>(3)</sup> Airbus Safran Launchers, P.O Box 801168, 81663 Munich, Email: axel.preuss@airbus.com

<sup>(4)</sup> Consultant, Email: guenter.langel@me.com

**KEYWORDS:** Green propulsion, ethanol, capacitive chamber, development status

**ABSTRACT:** In 2011 DLR and AEB agreed to cooperate in the field of liquid propulsion. The L75 engine project, which started in 2008 in Brazil, is the focus of this effort. The most important event in the project up to this date is the test campaign of the capacitive thrust chamber, a full-scale model of the L75 injection head and combustion chamber, which is the main focus of this paper, along with the status of other advances made in the project during the last year.

## 1. INTRODUCTION

The L75 liquid propellant rocket engine (LPRE) development started in 2008 in Brazil. Acquiring liquid rocket technology is the next logical step building on the existing solid rocket motor heritage and a key technology for mastering access to space. The Brazilian Space Agency AEB and its counterpart the German Aerospace Center DLR decided in 2011 to extend the more than 30 years of successful Brazilian-German space cooperation with so far strong focus on sounding rockets to the field of liquid propulsion [1].

The common work started with a review of the development status and a switch from the original Liquid Oxygen (LOX) -kerosene propellant combination to LOX-ethanol. Various factors supported this decision, such as the L5 engine tests in Brazil with LOX-ethanol, the LOX-ethanol know-how of German industry based on their past “green OMS” activities with Rocketdyne, the know-how within DLR Lampoldshausen based on the LOX-ethanol steam generators for altitude testing and last but not least the feasibility of future L75 sub-system or system hot-fire testing in Lampoldshausen due to environmental regulations.

Subsequently work was focused on the consolidation of the engine specification and the development plan.

The main topics of collaboration are on engine development strategy, thrust chamber and turbo pump development.

The design, manufacturing and testing of the capacitive thrust chamber hardware is currently the most visible effort. This full-scale hardware was manufactured in 2015, and the test campaign is scheduled from June 2016 until the end of this year, using two injection head designs: one Brazilian, done by IAE, and one German, done by Airbus Safran Launchers (ASL-Ottobrunn). Main objectives of these tests are to gain initial information on combustion efficiency and stability of both designs.

## 2. L75 ENGINE

The main requirements of the L75 are to provide 75 kN of thrust for an upper stage of a launch vehicle, with a burn time up to 400 seconds.

The choice for the gas generator cycle was due to its simplicity and the fact that it allows separate development of the engine subsystems.

The Thrust Chamber Assembly (TCA) employs a regenerative combustion chamber and dump-cooled nozzle extension, both cooled by the fuel.

The turbo pump assembly (TPA) is composed of an oxidizer pump, a fuel pump and a supersonic axial-flow turbine with partial admission, all assembled on a single shaft. Combustion gases from a LOX-ethanol gas generator (GG) feed the turbine.

The main propellant valves have pyrotechnical actuation, and the two regulation valves are servo-actuated.

Pyrotechnic igniters are used in the TCA and the GG. A pyrotechnic gas generator provides spin start for the turbo pump.

Figure 1 presents the engine flow schematic, and Figure 2 the digital mockup. Table 1 presents the main parameters of the engine.

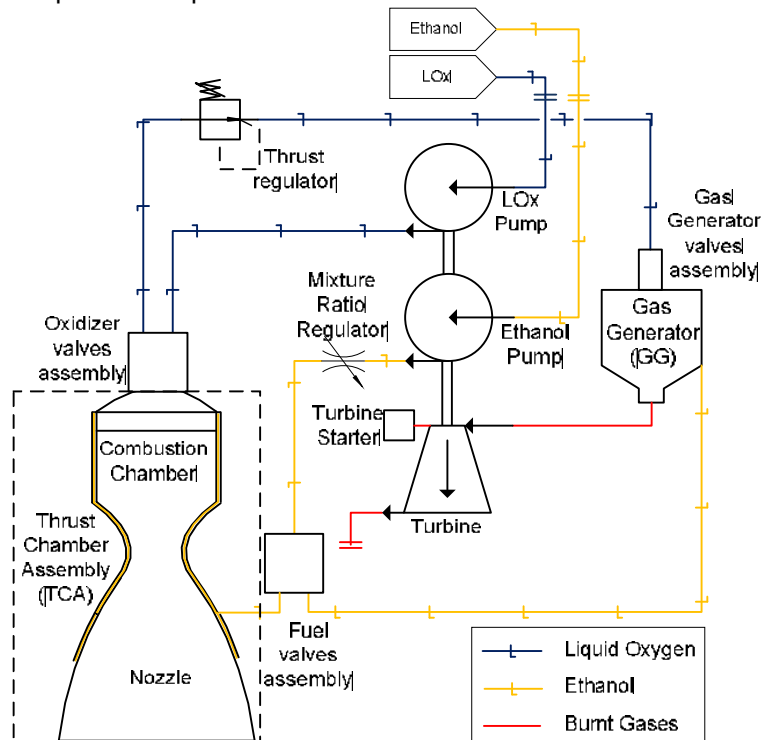

Figure 1. L75 flow schematic

Table 1 – L75 engine reference point data

Parameter	Value	Unit
Thrust in vacuum	75,0	kN
Specific impulse	315	s
LOX flow	14,4	kg/s
Ethanol flow	9,83	kg/s
Chamber pressure	5,85	MPa
Nozzle area ratio	147	-
GG pressure	4,82	MPa
GG LOX flow	0,31	kg/s
GG ethanol flow	1,00	kg/s
Turbine inlet temperature	900	K
Turbo pump shaft speed	24,2	krpm

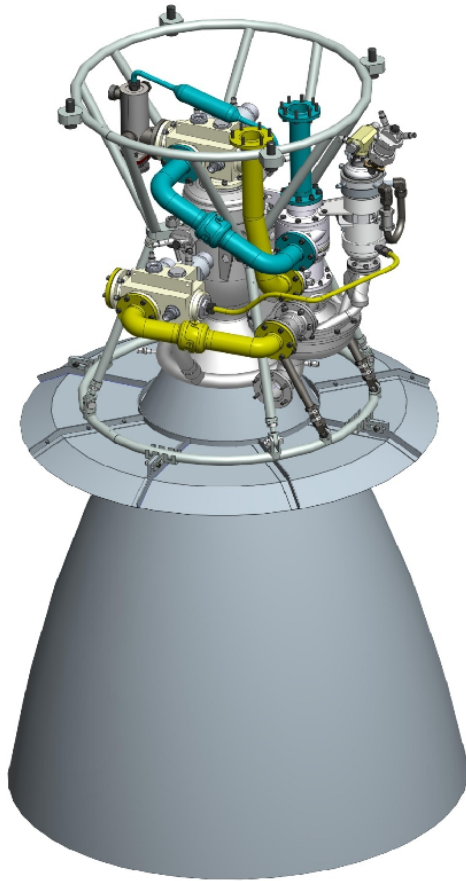

Figure 2. L75 digital mockup

### 3. DEVELOPMENT STATUS

#### 3.1 System Engineering

The engine development is supported by heritage of the parties involved. Existing data bases and experiences from previous programs were used for initial layout. Technological activities for combustion devices and powerpack components are initiated or ongoing to extend the data base to allow for mathematical models improvement. Functional models of the engine in steady state and transient conditions were developed. The steady-state model was used to define the engine operational envelope and derive requirements for its sub-systems. This same model can be used for engine tuning in later project phases. Figure 3 shows the L75 extreme envelope obtained with the steady state model.

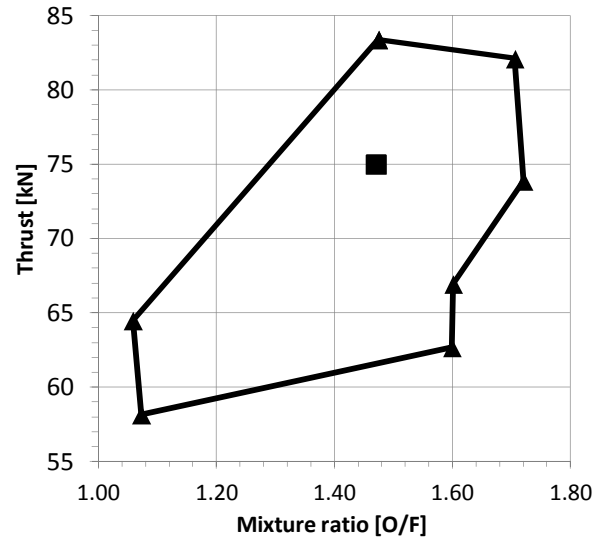

Figure 3. Engine extreme envelope

A fault detection algorithm for the L75 control system was developed with the transient model of the engine [2]. Frequency-domain and other dynamic specifications are being derived with the aid of this model.

#### 3.2 Component testing

Cold flow testing, using water as simulation fluid, has been performed for the oxidizer valve assembly, fuel valve assembly, gas generator valve assembly and mixture ratio regulator. Design changes were implemented for the gas generator valve assembly and the mixture ratio regulator. Flow tests for the valves have been repeated and further functional tests will follow. Design changes for the oxidizer/fuel valve assembly for pressure drop optimization are being proposed.



Figure 4. Gas generator valves assembly mounted for water flow test

### 3.3 Pump and turbine cold test stand

The pump test stand is operational for tests using water as simulation fluid. The LOX pump is installed and final checks are being in process to start the test campaign.



Figure 5. LOX pump test device being installed

On the turbine testing side, the nitrogen gas high-pressure feed line, which will drive the turbine, is mounted. Electrical integration with the control and acquisition system and the mounting of the turbine exhaust section shall take place after the LOX pump test campaign.

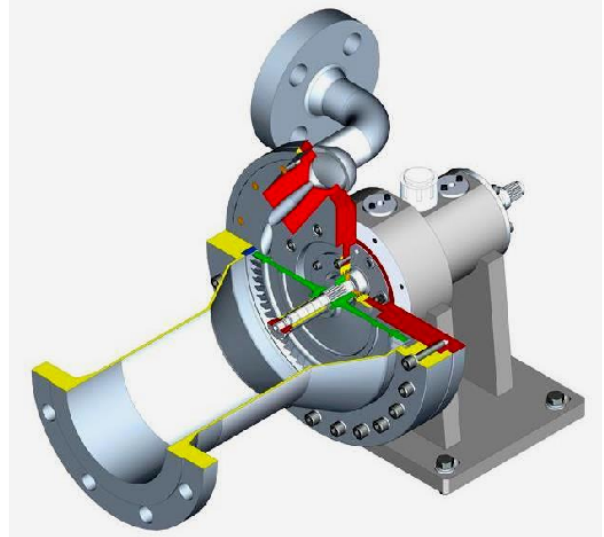

Figure 6. Turbine test device digital mockup

### 3.4 20 kN test stand

After the GG hot tests in 2014, the IAE's 20 kN test stand went through a major overhaul to increase its propellant pressurization capacity and enable full envelope testing of the L75 gas generator.

The test stand is now going through commissioning, focusing to deliver the capabilities to perform the GG hot tests with up to 500 g/s of LOX and 1,5 kg/s of ethanol, well below the upper limit of 5 kg/s for each propellant of the upgraded set-up.



Figure 7. Test cell of the 20 kN stand

## 4. THRUST CHAMBER PRE-DEVELOPMENT MODEL

In LPRE design, an early characterization of the thrust chamber behavior through initial hot tests is

mandatory to limit development risks. This is due to a great number of interacting phenomena, such as combustion and acoustics, with no possibility of accurate prediction by analysis.

One major step in thrust chamber design leads to a Capacitive Thrust Chamber (CTC) test, which allows a deep investigation on combustion phenomena and provides data for validation of the injector head design and thus for the achievement of operational requirements.

This thrust chamber configuration uses capacitive cooling for initial study of combustion behavior without the cooling jacket interference. This configuration reduces complexity and increases the precision of the input parameters, such as fuel temperature, fuel mass flow, and mixture ratio, and thereby ensures the repeatability of hot tests.

The main objectives of the CTC are to investigate the behavior of combustion stability in transient and quasi-static conditions, combustion efficiency and pressure loss. The combustion instability phenomenon is generally characterized by a coupling between energy release by combustion process and acoustic motion inside combustion chamber, which leads to pressure oscillations,

reducing  $C^*$  efficiency or even causing a complete destruction of the combustion chamber.

Capacitive cooling consists in a chamber wall with high thermal capacity and thermal conductivity, absorbing the maximum amount of combustion heat without melting, in order to increase operational test time. However, the typical test time for such configurations is limited to some few seconds only.

#### 4.1 Physical description

The CTC is split into three main sub-assemblies: the injection head, the cavity ring and the combustion chamber. A schematic view of the CTC physical elements is in Figure 8, a cut out view in Figure 9 and the assembled hardware in Figure 10. The three sub-assemblies of the CTC are bolted together, allowing for easy exchange of different combustion chambers and injection heads, depending on the test objectives.

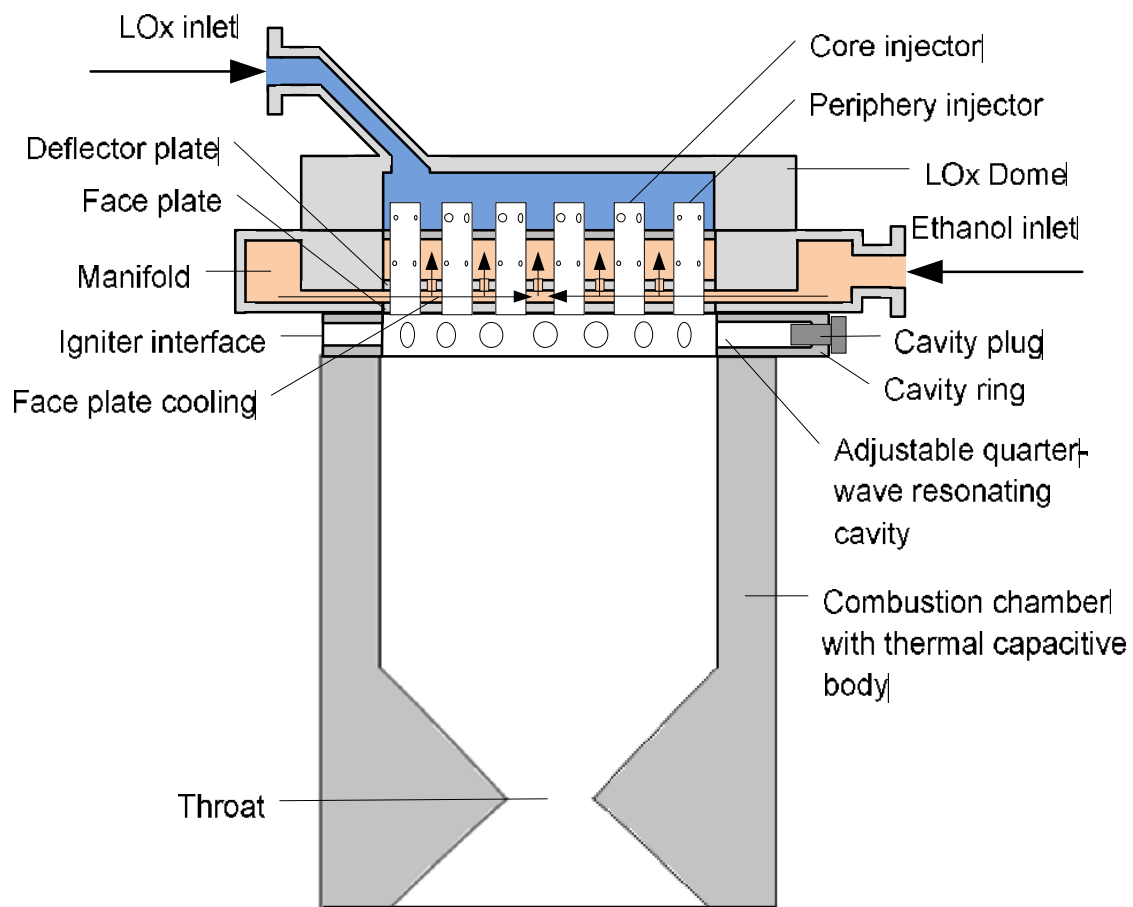

Figure 8. CTC physical architecture schematic

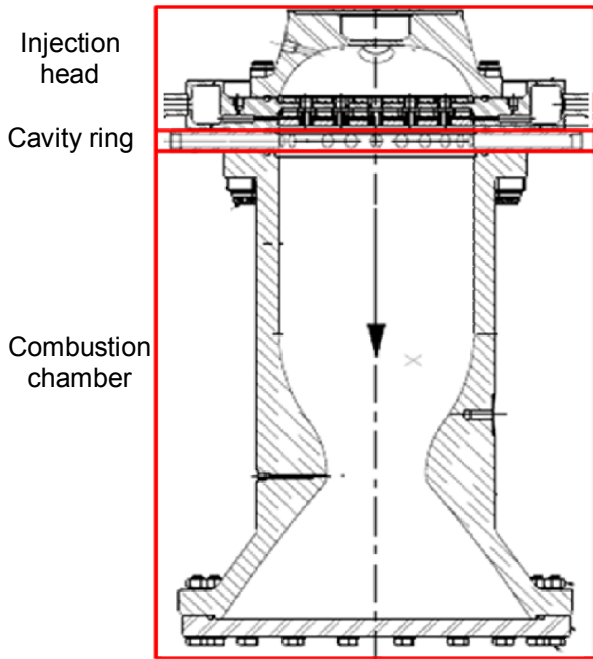

Figure 9. CTC cut out view



Figure 10. Assembled CTC hardware

For test representativeness, the CTC employs the identical injection system and combustion chamber internal contour as designed for the L75 TCA. The Brazilian injection head is designed with trimmed injection, in which the outer ring of injection elements have a lower mixture ratio for

lower combustion temperature and reduced thermal load. All other injection elements feed the core combustion region, designed with the mixture ratio for maximum specific impulse in vacuum. All injection elements are of bi-propellant double-swirl-coaxial type, with several applications in LOX-kerosene engines.

The cavity ring (Figure 11) is equipped with quarter-wave absorber holes. The cavities are foreseen to provide damping in case of occurrence of dynamic combustion disturbance. By adjusting the length of the cavity boreholes frequencies can be tuned and adopted to the chamber resonant frequencies. Table 2 presents the eigenfrequencies of the CTC up to 7 kHz.

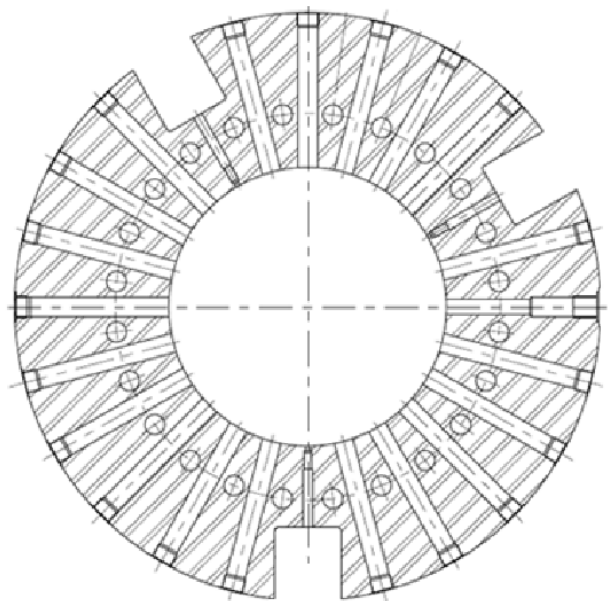

Figure 11. Cavity ring cut out view

Table 2 – CTC's eigenfrequencies lower than 7 kHz

Mode	Frequency [kHz]
1T	3,73
1L1T	4,09
2L1T	5,03
2T	6,19
3L1T	6,29
1L2T	6,41

#### 4.2 Development of the brazing process

An important accomplishment related to the manufacturing of the CTC hardware is the development of the injection head brazing process by IAE.

The development started with several small-scale injection head brazing models, as shown in Figure 12 and Figure 13, to evaluate the effect of process parameters in responses such as the wettability of the brazing paste, leak tightness of the assembly and material properties recovery after post brazing heat treatment.



Figure 12. Small-scale injection head brazing model showing the faceplate

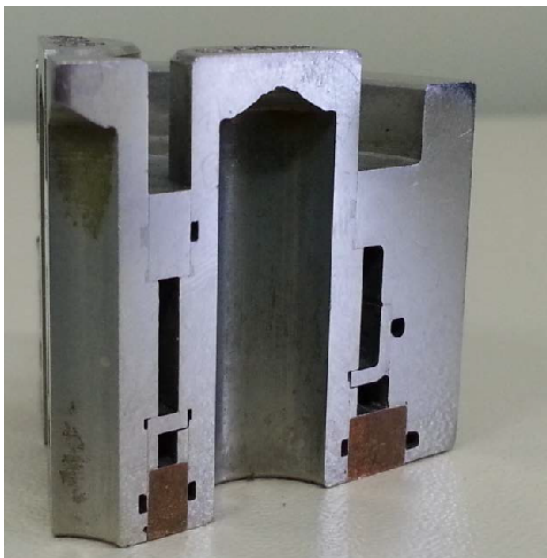

Figure 13. Small-scale injection head brazing model cut out

The manufacturing of a full-scale blind injection head followed the small-scale ones. Leak tightness tests and proof pressure tests were cleared on the blind injection head before manufacturing the one with real injectors (Figure 14), which also passed through leak tightness, pressurization and flow tests.

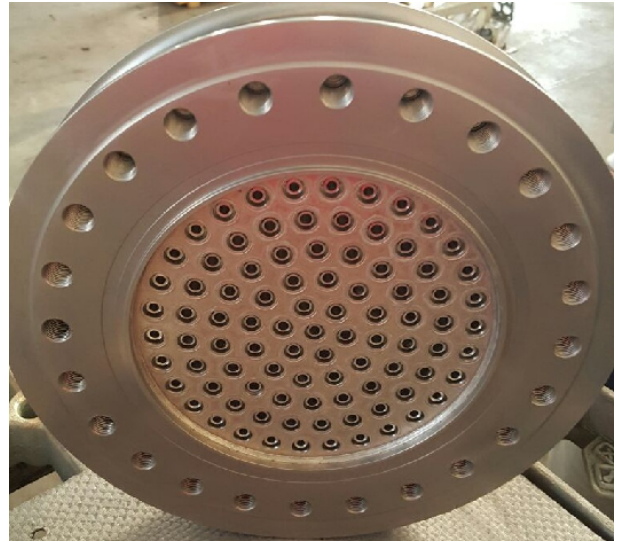

Figure 14. Full-scale injection head

#### 4.3 Alternative injector head design

For the common test campaign, ASL-Ottobrunn will provide a second, alternative injector head design based on the L75 operational specification. The two injector heads will act as back up for each other in order to use the test slot as efficiently as possible and allow for hardware modification or adaptations, e.g. cavity ring tuning or necessary detailed data analysis without losing valuable test time.

The ASL-Ottobrunn injection element is based on best practice elaborated within years of operating storable propellant systems, as well as on know-how gained during some "green OMS" activities. It is characterized by a swirl / slot design. The injector head's general design allows for implementing classical baffles or liquid baffles in case of any instability issues.

It is planned to perform the initial tests with the capacitive combustion chamber provided by IAE. Figure 15 shows a 3D view on the injector head including an ASL igniter/measurement ring.

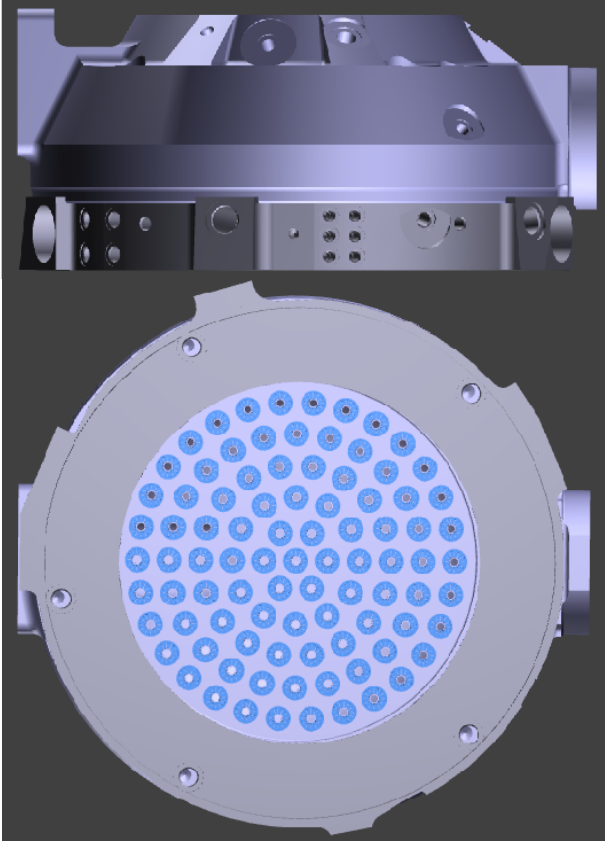

Figure 15. ASL-Ottobrunn injector head design

#### 4.4 Testing

The points of technical interest for the CTC test campaign are derived from the L75 extreme envelope points. The extreme operational envelope defines a region of the operational space in which the engine and its components shall present positive safety margins. Its definition takes into consideration engine requirements, operational limits and safety criteria for the engine components.

Figure 16 presents the CTC test envelope and the combustion chamber design point inside it. The test campaign will focus on obtaining combustion stability data in the lower left quadrant, and combustion performance data in the upper right quadrant.

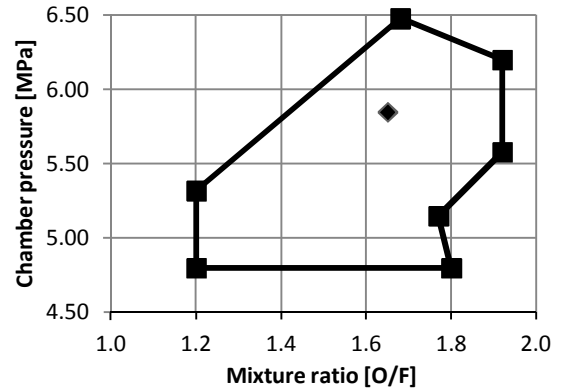

Figure 16. CTC test envelope and design point

The P8 test stand at DLR Lampoldshausen (Germany), shown in Figure 17, will be used for the test campaign starting in June 2016. An ethanol supply will be added to the facility during an upgrade directly preceding the test period. Currently P8 has LOX, GH2/LH2 and GCH4/LCH4/LNG high pressure propellant supplies. Further details on P8 test facility history and capabilities, as well as, on the ASL-Ottobrunn test heritage can be found in [3] and [4].

The test points will require mass flows up to 16 kg/s of LOX and 9,4 kg/s of ethanol, and feed pressures up to 80 bar in the LOX inlet and 115 bar in the ethanol inlet.



Figure 17. P8 test stand at DLR Lampoldshausen

Capacitively-cooled combustion chamber bodies made of copper and steel will be used. Initial tests will run with the more robust steel chamber, when the ignition sequence is still being optimized, allowing only short duration tests (<1 second) to evaluate stability during the ignition transient. The copper chamber will allow the measurement of quasi steady state combustion, providing data on combustion stability during operation and a glimpse of combustion efficiency in longer burns (around 3 seconds).



The acoustic damping cavities of the cavity ring will be used if any instability or low damping are present, or remain plugged otherwise. A bomb test, to excite acoustic modes of the chamber, is planned to be performed during transient or steady state operation to evaluate the damping performance of the system. Vacuum ignition tests are also envisaged.

After the investigation of stability related issues, a water-cooled combustion chamber provided by ASL-Ottobrunn will allow tests in steady state regime at several test points in a single burn. This phase will provide data on combustion efficiency and an initial idea of the integral heat load.

## 5. CONCLUSION

The paper presents the status of the cooperation of DLR and IAE for the development of the L75 engine. The progress obtained in 2015, as well as the expected goals in 2016 are included. A major cooperative effort in 2016 is the test campaign of the capacitive thrust chamber, which is on schedule to take place at P8 test facility under responsibility of ASL-Ottobrunn at DLR/Lampoldshausen, Germany.

## 6. ACKNOWLEDGMENTS

The German activities are financed by DLR with funds of the German Federal Ministry for Economic Affairs and Energy (reference: 50RL1411). IAE thanks the Brazilian Space Agency AEB for funding the L75 project.

## 7. REFERENCES

1. Almeida, D.S., Pagliuco, C.M.M. (2014). Development Status of L75: A Brazilian Liquid Propellant Rocket Engine, J. Aerosp. Technol. Manag., São José dos Campos, Vol.6, N° 4.
2. Araujo, L.M., (2016). Design of a Fault Identification System for the L75 Liquid Rocket Engine, Master's Thesis, ITA, São José dos Campos, Brazil.
3. Habertzettl, A., (2000). European Research and Technology Test Bench P8 for High Pressure Liquid Rocket Propellants, AIAA-2000-3307, 36th Joint Propulsion Conference, July 16-19, 2000, Huntsville, Alabama, USA.
4. Preuss, A., et al. (2009). 10 Years of Subscale Testing at P8 Test Facility Lampoldshausen, EUCASS2009- 235, 3<sup>rd</sup>