

Multi-fidelity Parametric Cabin Component Modeling Approach for Application-driven Geometry Generation

Ganesh Vivek Rajendran, Jan-Niclas Walther, Jörn Biedermann, Björn Nagel

DLR Institute of System Architectures in Aeronautics, 21129 Hamburg, Germany

Abstract:

The aircraft cabin geometry is essential at many stages of the aircraft design process, ranging from preliminary design to detailed virtualisation. At each stage, for analysis purposes, a geometry model with an appropriate fidelity level is required. The aircraft cabin includes full-height components like closets, galley, and lavatory. This paper proposes a methodology, which derives CAD geometry for aircraft cabin full-height components from a set of design parameters at multiple distinct fidelity levels. Based on the complexity and for demonstration purposes, the galley model is selected.

The galley's parametric description is based on data provided by the Common Parametric Aircraft Configuration Schema (CPACS), an established data model for aircraft design, and enhanced by component-specific parameters. The multi-fidelity model is the combination of low fidelity and high-fidelity models based on this description. The CAD geometry generation has been implemented using the Open Cascade Technology (OCCT) library. The multi-fidelity model provides consistent CAD geometry according to the model generation requirements of different disciplines based on the same set of parameters.

The approach presented helps to accelerate multi-disciplinary design cycles, as tailored geometry with as little overhead as possible is available for disciplinary model generation. The CAD geometry generated in this model can be applied to experience aircraft cabin designs in virtual reality or to analyse the dependencies between the aircraft cabin components and other systems. Furthermore, it can be used to validate the proposed enhanced cabin schema containing more detailed data about the cabin components.

Keywords

CPACS, Cabin, Multi-fidelity, CAD, Open Cascade Technology, Virtual Reality

1. Introduction:

At present, the Virtual Product is an important research topic at the German Aerospace Center (DLR) [1]. The development, testing, and production of new aircraft designs are associated with financial risk and time [1, 2], which restricts new or existing companies to expand their catalogue to new components. Virtual Products help to shorten the design cycle by reducing time consumption for analysis, validation, and certification. In this way, companies can be encouraged to add new components to their catalogue with decreased management and technological risks. DLR is performing research in the field of Virtual Products [2]. The Institute of System Architectures in Aeronautics is focusing on adding aircraft cabin components to its virtual Portfolio.

Engineers and researchers have different geometrical models for computational design and analysis tasks [3], and the output of each geometrical model deviates from the actual physical model. The design process begins with less accurate low fidelity geometrical models and proceeds to precise high-fidelity geometrical models. The fidelity level is linked to the detail of the geometrical model.

One of the critical aspects of designing aircraft cabin components is managing their connections and dependencies [4]. When an individual aircraft component is

modified, there are no modification traces to other dependent components. Therefore, it is always important to have traceability of links between the components. For example, when an aircraft seat position is modified, the seat location placards must be aligned with the seat position. Consequently, the aircraft seat and seat location placards are linked to each other.

Another critical aspect is communicating a constant geometry definition across the various disciplinary analyses. The geometrical requirements for each disciplinary analysis vary. For example, LOPA (Layout of Passenger Accommodations) or space allocation geometrical requirements are lengths, width and height for visualisation analysis or VR, additional geometrical details are required to generate the appropriate shape and equipment information, and for strength analysis like FEM, the geometrical model requires attachment information in addition to the visualisation or virtual reality (VR) model. In all cases, the length, width, height and some shape information are common. These geometries indicate that the communication of constant geometry definition is essential. The constant geometry definition is based on component-specific parameters. The Common Parametric Aircraft Configuration Schema (CPACS) is a central data model [5, 6, 7] and enhances the communication between various

disciplines. It also enables the traceability of links or dependencies between the components [8].

This paper presents the Virtual Cabin Component Environment (VCCE) package, the CAD geometry generator for aircraft cabin components. It translates parametric data from CPACS or VCCE GUI inputs into CAD geometry using the Open Cascade Technology (OCCT) library [9]. This application-driven VCCE Geometry Generator demonstrates the interoperability of geometry generation and CPACS data. For demonstration purposes, the galley model with medium complexity is selected to explain the capabilities of this package.

2. CPACS and Geometry Library

CPACS, developed at the DLR [5, 6, 7], is gaining popularity among engineers as the standard data exchange format for collaborative aircraft design processes between various disciplines. The projects like Agile, VicToria, Digital-X uses the CPACS to achieve the goal of multi-disciplinary optimisation (MDO) [10, 11, 12]. CPACS is based on hierarchically structured data sets in XML standards shown in Figure 1(a). It includes the parametric description of the aircraft model and allows the exchange of data and information across the components and disciplines [4]. It links data from different product lifecycle phases in a meaningful way and allows their evaluation by applications in the digital thread [13].

Most of the geometrical libraries are in C++ format. DLR has created its geometrical library named TiGL Geometry Library [14, 15]. It is an open-source program written in C++ and provides interfaces to other programming languages like C, C#, JAVA, MATLAB and Python. The geometry library generates geometry based on the parameter data, and it generates both the interior and external geometry of an aircraft from the parametric description in CPACS. TiGL uses the open-source OpenCascade Technology (OCCT) CAD kernel [9] to generate the geometries. The TiGL package includes the TiGL viewer to visualise the generated geometry, as illustrated by Figure 1(b).

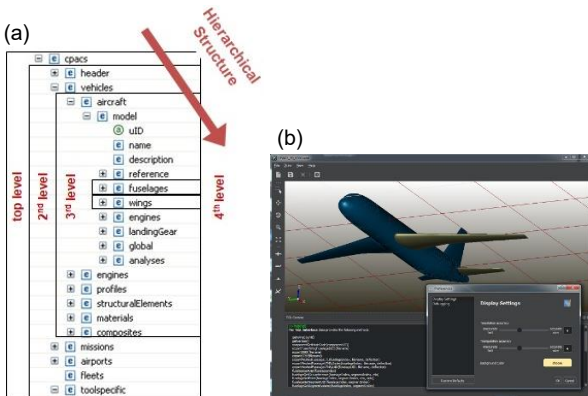

Figure 1 (a) CPACS Hierarchically Structured as XML tree; (b) a screenshot of the TiGL Viewer, which displays CPACS geometries [14] [15]

3. Multi-fidelity

This chapter explains the multi-fidelity parametric modelling approach. The cost-effective and time saving low-fidelity model is engaged in the earlier design phase to explore, e.g. the space allocation [3]. The expensive and more precise high-fidelity model is used when sufficient data is obtained about the design [3]. Using high-fidelity geometry in the early design phase enables high-fidelity analysis sooner, which reduces the cost of implementing detailed engineering work in future. The geometrical design of high-fidelity analysis models can vary with disciplinary requirements. The model with varying fidelity attains the status of multi-fidelity [16].

Applied to the example of cabin components, the low-fidelity model describes the size. Incorporating boundary conditions to represent analytical model geometries and the model becomes an example of multi-fidelity geometry by adding these boundary conditions into the design parameters [16].

The parametric model can modify its geometry when a parameter value is modified. For example, a rectangle has three parameters (length, width and height); when a parametric value has been modified, the geometry of the rectangle modifies.

Whereas in the multi-fidelity model, the parameters remain the same. However, based on the fidelity, the geometry detail varies. For example, a rectangle with a hole has the following parameters: Length, width and height of the rectangle, diameter, depth and position of the hole. Here the parameters do not change, but the geometry generated varies with fidelity levels. Figure 2 shows the example multi-fidelity model. Level 0 generates the geometry as a topologically two-dimensional surface. Level 1 generates the geometry as a three-dimensional body, and Level 2 adds the hole detail to the geometry. The parameters are the same in all three levels, but the details of the geometry change with the fidelity levels.

The multi-fidelity parametric model combines the benefit of both the parametric model and multi-fidelity model. In general, the term multi-fidelity represents the multi-fidelity parametric model.

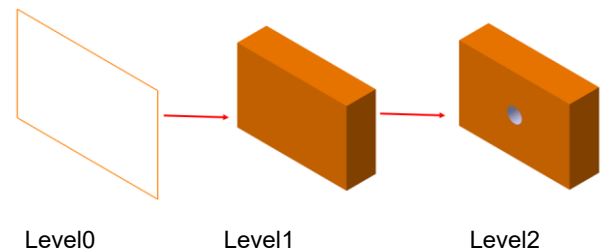

Figure 2 Example Multi-fidelity model

In this paper, based on our study about full high aircraft components,

- the design of the closet model is simple compared to the sidewall, PSU panels, seat or lavatory
- also, the galley model is simple as a closet but become complex by adding equipment

- the design of the lavatory model is complex comparing closet and galley become more complex by adding equipment and piping

Based on the complexity of the aircraft cabin component, the moderately complex galley model is selected as an example to demonstrate the multi-fidelity parametric approach. It is an aircraft full height cabin component. The parametric description of the galley can be stored in CPACS.

4. Multi-Fidelity Modeling Software Architecture

VCCE is a software package under the development phase, and all of its dependency's packages are open source. VCCE acts as a central data module (see chapter 5). Like TiGL, it relies on the open-source OCCT CAD kernel and CPACS. OCCT is used to perform the geometrical and topological modelling of the CAD data, create solids via constructive solid geometry (CSG) and visualisation [14, 9]. CPACS is used to provide input on the aircraft. The VCCE package is based on C++ objects and classes and contains data and methods. The software architecture of VCCE to generate CAD geometry from parametric data is shown in Figure 3. VCCE contains many modules for different purposes of the package.

This package's input module includes the component-specific parameters module; the input can be read from a central data model or be created or modified using VCCE's GUI. The schema has parametric information of cabin components. The required fidelity level has to be selected to generate the desired geometry. The parametric data from the VCCE GUI enables the inside-out design process, and on the other hand, external data from the CPACS schema is included in an outside-in design process.

Each aircraft cabin component parameter is stored as an independent object in the design algorithm module. Also, the design algorithm module stores the knowledge and design rules of the aircraft cabin component. The design algorithm includes geometric knowledge from diverse disciplines and design levels ranging from low-fidelity to high-fidelity. The high-fidelity level requires adequate details to generate a reliable solution. The design algorithm possesses the traceability of links or dependencies to other components. For example, see Figure 4 the width of the aircraft cabin components sidewall, overhead stowbin, dado panels, ceiling panels are attached to the aircraft frame. When the position of the frames changes, the dependent components as well change their position. Also, when the gap between the frames are modified, the dependent components as well of modify its length. The link and dependency relationships are stored in the object structure.

The design algorithm in VCCE helps for the following application,

- Multi-fidelity generation geometry for different analyses like space allocation, visual analysis or VR and stress analysis

- Positioning and interface checking between the aircraft cabin components at installation level virtually

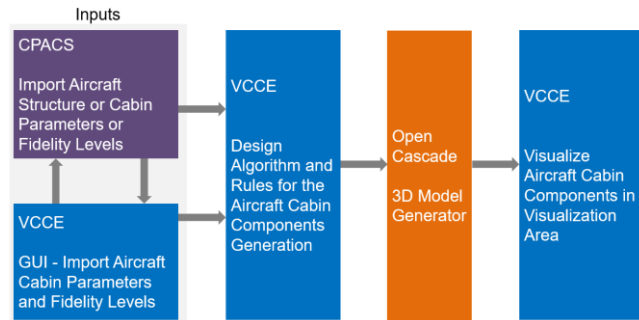

Figure 3 Software Architecture of VCCE

The 3D Model Generator module includes operations like building the curves and surface required to build the geometry. All these operations are based on OCCT. The input module defines parametric points. Then these points are used to build-up curves, which are connected to create; eventually, several surfaces joined together to form the solid [14, 17]. The Boolean operations are used to achieve the desired shape. OCCT's visualisation modules are used to visualise the generated geometry in the visualisation area.

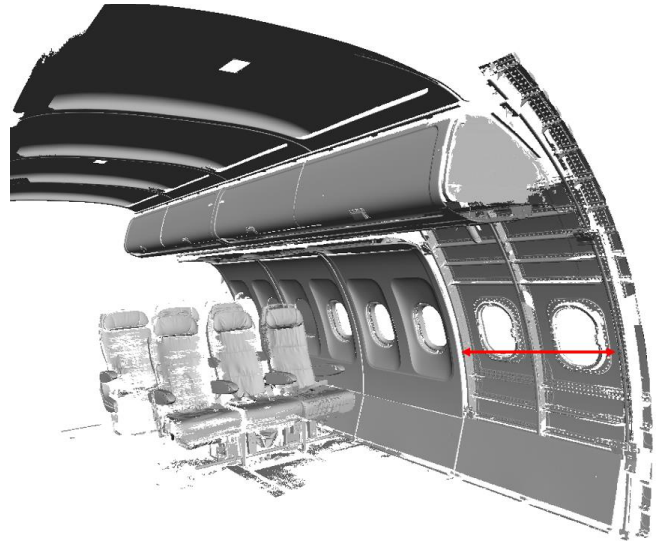

Figure 4 A320 Mock-up 3D Scan Model [18]

5. VCCE Central Data Model

VCCE provides an object-oriented central data model developed specifically for the aircraft cabin components design. The central data model is designed to be flexible to adopt the intended cabin component's design. It enables the capability to generate various cabin components in different fidelity levels. [19] As illustrated by Figure 5, the VCCE central data model incorporates three main elements: Storage, Construction Rules and GUI.

Storage: The parametric description of the aircraft cabin components are stored on disk in CPACS XML format.

Construction Rules: The stored parametric descriptions are read, and the construction rules algorithm converts the parametric description to a geometric model. The geometric model used in this package is OCCT Model. Support for commercial environments like CATIA V5 or 3D Experience can be added to the software in future.

GUI: Here, the parametric descriptions from storage are read and displayed in GUI. The engineer can change the parameters and save them back to the storage or pass the parametric description to the Construction Rules element.

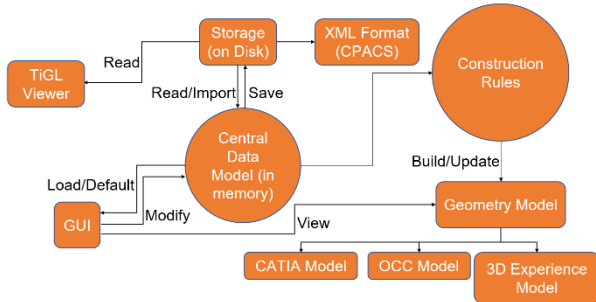

Figure 5 Central Data Model

6. Example Case and Discussion

This chapter shows multi-fidelity CAD geometry for the galley model and compares the CAD geometry between different fidelity levels. This comparison shows the benefit of using a multi-fidelity parametric modelling approach.

6.1 Applications for different levels:

The multi-fidelity approach aims to generate different CAD geometry for different analyses specifically. In this chapter an overview of the possible applications of the different CAD geometry levels are explained. Table 1 shows the application of different fidelity levels.

Multi-fidelity levels 0 and 1 CAD geometries support the creation of the LOPA and Space allocation. These CAD geometries assist in finalising the 3D space for the components in the aircraft.

The level 1 and level 2 CAD geometries help to visualise the components in the initial stage. These CAD geometries give an early idea about how the components appear. These CAD geometries support the engineer in deciding on the design of the component. The engineer can alter the value of the parameters to achieve the desired design.

The level 3 CAD geometry is used for detailed visual analysis of the component. This CAD geometry is also used to find the clashes between the elements present in the component.

Level 4 can be used for FEM analysis. This CAD geometry is generated based on the design rules considered for FEM analysis. The CAD geometry generated in this level does not have holes, but they have attachment points instead of holes.

These points define the load transmission through the fasteners and calculate the stress distribution on the elements (brackets and panels).

Level 5 is a high-fidelity design model, which has very detailed information about the component. This design includes holes, thickness.

Levels	Application
Level 0 and 1	Lopa Creation or Space Allocation
Level 1 and 2	Initial Visualization
Level 3	Visualization and Clash Analysis
Level 4	FEM Analysis
Level 5	Detail Model

Table 1 Application of different levels

6.2 Galley model Level 0:

Figure 6 shows the multi-fidelity CAD geometry galley model at level 0; level 0 is the lowest level of this tool's multi-fidelity and is called the low fidelity model. On the left side of Figure 6, the minimum parameters required to build this CAD geometry are shown. They are width, height and lengths at various heights. The X-direction, Y-direction, Z-direction represent the model's width, length and height, respectively, in this paper. When the positioning of the galley model is at the centre of the aircraft, only one value of the lengths in Y-direction is required. However, when the position of the galley model is at the outboard side of the aircraft, multiple values of the lengths in Y-direction are required. These multiple values generate the curve profile at the outboard side, as shown in Figure 6. In the future, this could be linked to geometry generated from CPACS [20].

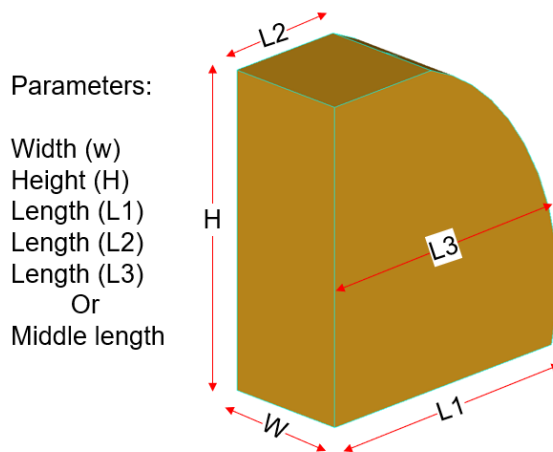

Figure 6 Level 0 full model view

6.3 Comparison of Level 0 and Level 1:

Level 0 represents the outer shape of the galley model. However, level 1 represents the wall, inside panels and equipment of the galley model as surface. On the left side of Figure 7(a), the additional parameters required to build galley model level 1 from level 0 are shown. The parameters are the number of horizontal and vertical panels, and the trolley details and Level 1 show the galley model's view with panels and equipment as surfaces.

Parameters:

- No.of Horizontal Panels
- No.of Vertical Panels
- No.of Trolleys

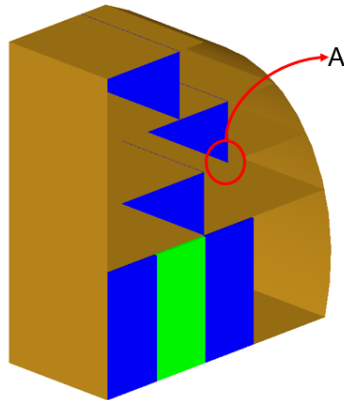

(a) Full model view

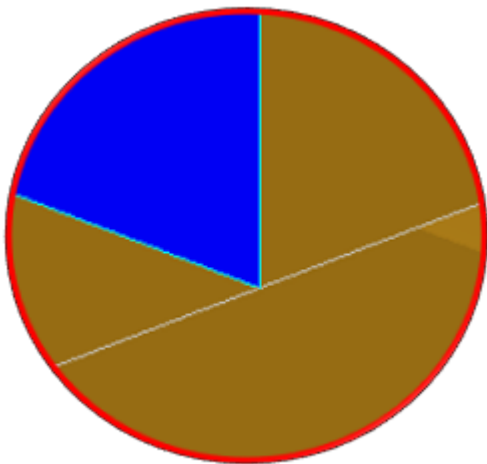

Detail A

(b) Detail view

Figure 7 Level 1 – Simple Surface

6.4 Comparison of Level 1 and Level 2:

The galley model at level 2, also called Simple Panel, is shown on the Figure 8(a). Level 2 looks similar to level 1; however, level 2 has additional detail (thickness) of panels. The detailed view in Figure 7(b) and Figure 8(b) shows the difference between level1 and level2. The thickness of horizontal, vertical, and frame panels (including galley

outboard, inboard, forward or aft panel) is modified independently. The thickness of each horizontal panel can be different and modified independently.

Parameters:

- Thickness of Horizontal Panels
- Thickness of Vertical Panels
- Thickness of Frame Panels

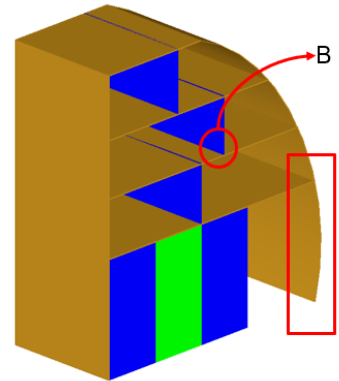

(a) Full model view

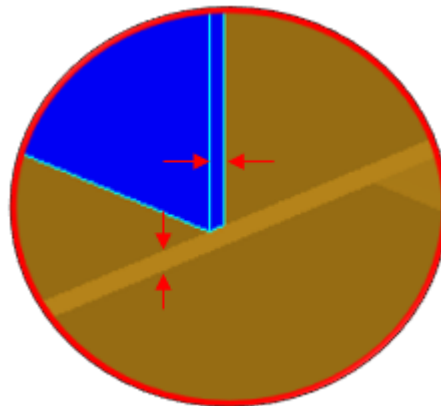

Detail B

(b) Detail view

Figure 8 Level 2 – Simple Panel

6.5 Comparison of Level 2 and Level 3:

The galley model level 3 shows the detail panel shape and attachment information, comparing with level 2. The details are,

- detail panel shape
- number of brackets required to attach a panel to galley model
- number of brackets required to attach the galley model to the aircraft floor

Detail panel shape:

The rectangle highlighting in Figure 8(a) and Figure 9(a) shows the panel comparison on the outboard side of the galley model between level 2 and level 3. The manufacturing of curved panels is expensive and complex to assemble. To reduce the manufacturing cost and complex assembly procedure, it is better to have a straight panel on the outboard side.

The number of brackets required to attach a panel:

Every panel requires brackets to attach the panel to the galley frame or neighbouring panel, and the frame panels are held together with the help of brackets. The default number of brackets are four brackets for each panel. The detail views in Figure 8(b) and Figure 9(b) shows the bracket attachment between the panels. The number of brackets can be modified independently.

The number of brackets required to attach the galley model:

The number of brackets required to attach the galley model to the aircraft floor usually depends on the weight of the galley model and the weight of the equipment and load transferring capacity of the fastener. In this example, the number of brackets positioned on the inboard and outboard sides of the galley is two. The number of brackets positioned on the backside of the galley is three. The number of brackets on each side can be modified independently. However, in future, the number of brackets required can be calculated from the weight of the galley and the equipment.

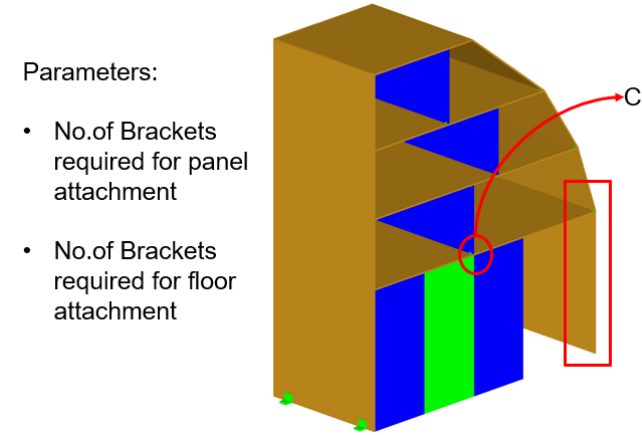

(a) Full model view

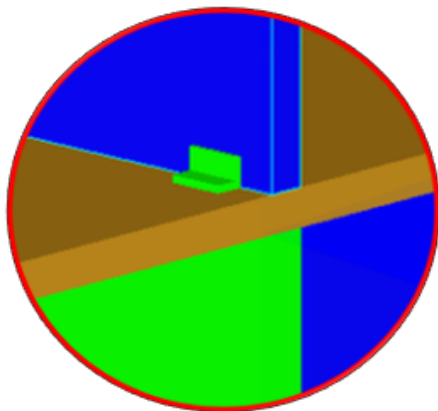

Detail C

(b) Detail view

Figure 9 Level 3 – Model with attachment

6.6 Comparison of Level 3 and Level 4:

The galley model level 4 belongs to the high-fidelity model and has an attachment point to represent the fastener. These points help the structural analysis engineer to perform the stress calculation. The minimum parameters required to design a bracket are fastener diameter D and thickness of the bracket T . The design rule to find the minimum length of the bracket is

$$L = 2 * (1.5D) + 2D$$

and the minimum width of the bracket is

$$W = T + 2 * (1.5D)$$

where $1.5D$ is the edge distance and $2D$ is the pitch distance between the holes.

Figure 9 and Figure 10 shows the comparison between the level 3 model and the level 4 model. The significant difference is that level 4 has fastener attachment points comparing with the level 3 model. The fastener points are visible in detail view Figure 10(b).

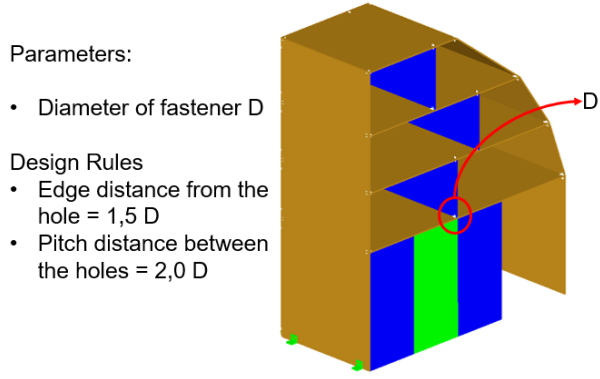

(a) Full model view

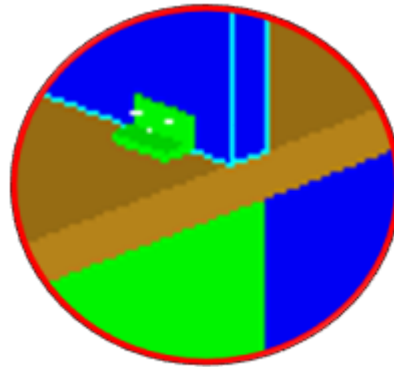

Detail D

(b) Detail view

Figure 10 Level 4 – Model with attachment and attachment points

6.7 Comparison of Level 4 and Level 5:

The galley model level 5 is the detailed high-fidelity galley model. This level is the highest fidelity model with complete galley details. The significant difference between level 4 and level 5 is that level 5 has a physical hole for attachment, whereas the level 4 galley model has only attachment points. Figure 11(a) shows the full view of the level 5 galley model, and Figure 11(b) show the detailed view of panel attachment, and from Figure 11(b), it's understandable that the bracket has physical holes.

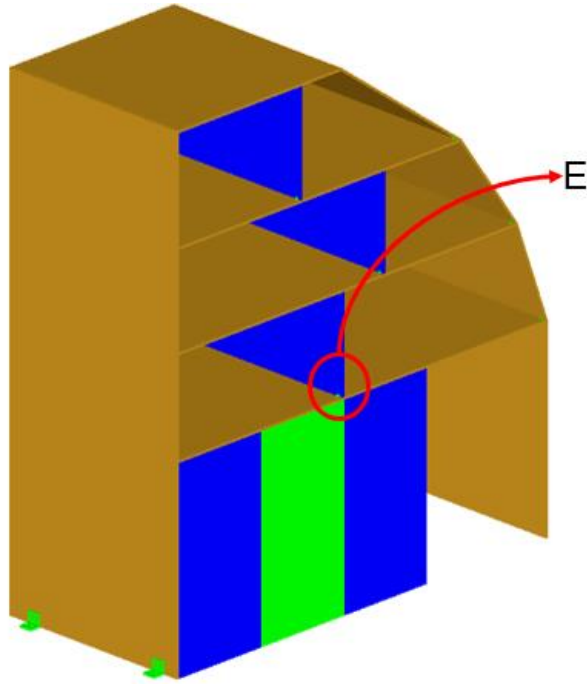

(a) Full model view

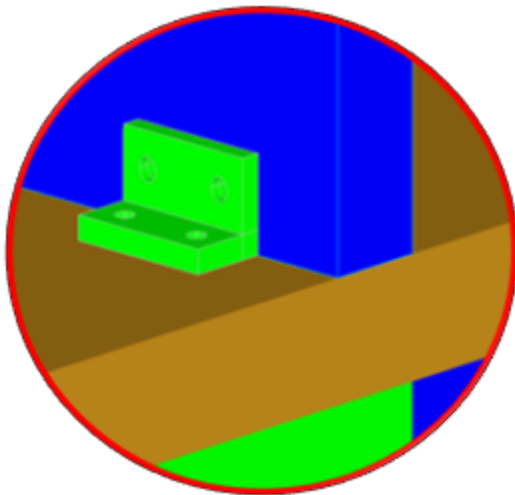

Detail E

(b) Detail view

Figure 11 Level 5 – Detail Model

6.8 Before and after modification:

Here is the output CAD geometry when few parameters are modified. For example, modify two parametric values. They are,

- modify the position of a horizontal panel
- modify the position of a vertical panel

Figure 12 shows the CAD geometry output before modification and after modification.

When the position of a horizontal panel is modified, the length of the relevant panels is modified. Also, the bracket positions were adjusted. The green arrow line indicates the change in length of the vertical panels and outboard frame panels. The brackets in the green circle indicate the relevant movement.

When the position of a vertical panel is modified, the positions of the relevant brackets are adjusted. The brackets in the yellow circle indicate the relevant movement.

All panels and brackets are linked to each other. When any parametric value is modified, the relevant movement or modification are updated automatically. This automatic update illustrates how every element in the galley component is either linked or dependent on each other.

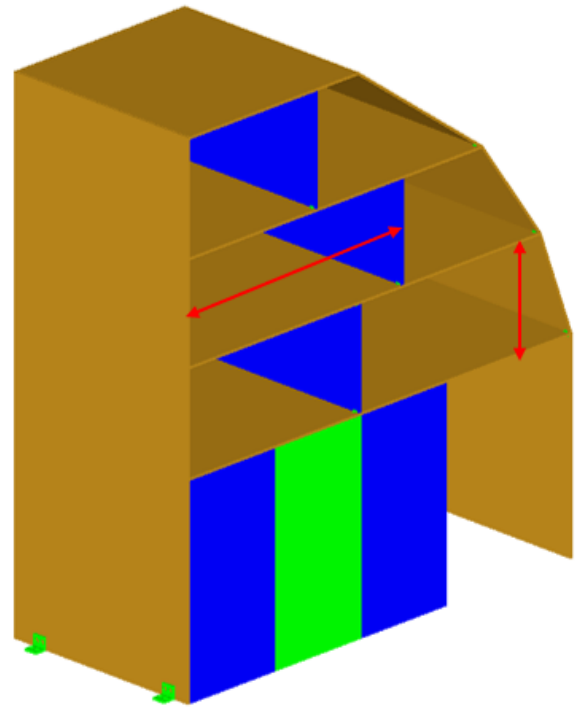

Before

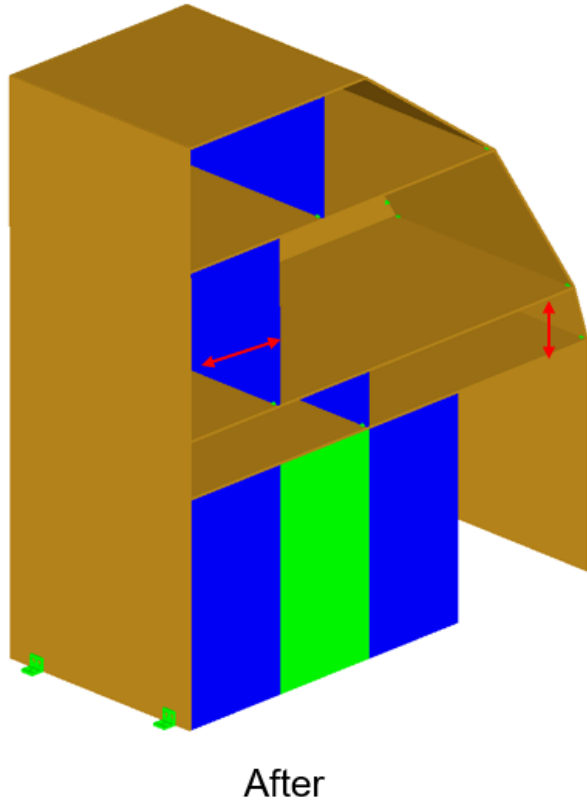

Figure 12 Before and After modification

7. Conclusion and Future Scope

This paper presented the VCCE software, an automated approach for deriving consistent cabin component geometry models. VCCE translates component-specific parameters into multi-fidelity geometries. It can be used in the aircraft cabin components design optimisation process by changing the component-specific parameters and regenerate the geometry in VCCE. VCCE helps to accelerate the design cycle time of aircraft cabin components, which directly reduces the cost of the component. The component-specific parameters are processed in the knowledge-based design system to generate consistent tailored geometry models, which can be made available to various disciplines. This way of model generation helps to ensure geometric consistency among disciplines in multi-disciplinary processes. The multi-fidelity modelling generally ensures consistency between various disciplinary abstractions of the component geometry.

In future, a module needs to be developed to read and modify the CPACS parametric data using the GUI and improved support for modelling directly using the GUI. Figure 13 shows the example GUI for the galley model.

Another future scope of the software is to include commercial CAD kernels like CATIA V5 and 3D Experience.

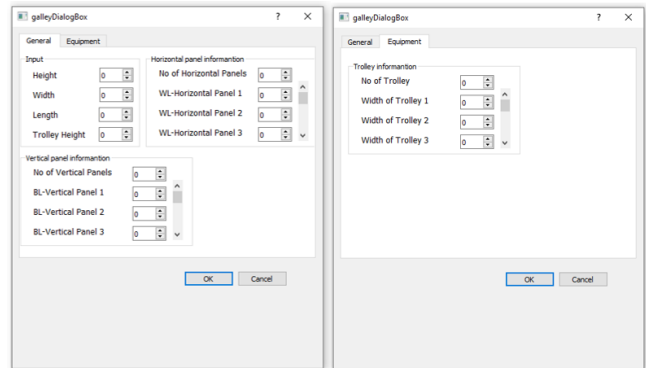

Figure 13 Example GUI for galley model

References

- [1] "DLR - Virtual product," [Online]. Available: <https://www.dlr.de/content/en/articles/aeronautics/guiding-concepts/virtual-product.html>.
- [2] "DLR - Virtual Product House," [Online]. Available: <https://www.dlr.de/content/en/articles/aeronautics/aeronautics-research/virtual-product-house.html>.
- [3] D. E. Christensen, "Multifidelity Methods for Multidisciplinary Design Under Uncertainty," Master thesis, Massachusetts Institute of Technology, 2012.
- [4] M. Fuchs and F. Beckert, Experience of cabin designs in virtual reality, ONERA-DLR Aerospace Symposium, 2020.
- [5] B. Nagel, D. Boehnke, V. Gollnick, P. Schmollgruber, A. Rizzi, G. La Rocca and J. Alonso, "Communication in Aircraft Design: Can we establish a Common Language?," in *International Council of the Aeronautical Sciences*, Brisbane, Australia, 2012.
- [6] M. Alder, E. Moerland, J. Jepsen and B. Nagel, "Recent Advances in Establishing a Common Language for Aircraft Design with CPACS," in *Aerospace Europe Conference*, Bordeaux, Frankreich, 2020.
- [7] "CPACS," Deutsches Zentrum für Luft- und Raumfahrt e.V, 2018. [Online]. Available: <https://cpacs.de/>. [Accessed August 2021].

- [8] J.-n. Walther and P. D. Ciampa, "Knowledge-based automatic Airframe Design using CPACS," in *CEAS Conference*, 2017.
- [9] "OpenCascade," [Online]. Available: <https://www.opencascade.com/>. [Accessed 2021].
- [10] "AGILE Project Homepage," 2021. [Online]. Available: <http://www.agile-project.eu/>. [Accessed August 2021].
- [11] S. Görtz, A. Krumbein, M. Ritter and J. Hofmann, "DLR-Projekt VicToria- Virtual Aircraft Technology Integration Platform," in *Deutscher Luft- und Raumfahrtkongress*, 2018.
- [12] N. Kroll, "DLR Project Digital-X: towards virtual aircraft design and flight testing based on high-fidelity methods}," *CEAS Aeronaut J (CEAS Aeronautical Journal)*, vol. 7, no. 1, p. 3–27, 2016.
- [13] H. Meyer, J. Zimdahl, A. Kamtsiuris, R. Meissner, F. Raddatz, S. Haufe and M. Bäßler, "Development of a Digital Twin for Aviation Research," in *Deutscher Luft- und Raumfahrt Kongress*, Germany, Online, 2020.
- [14] M. Siggel, J. Kleinert, T. Stollenwerk and R. Maierl, "TiGL: An Open Source Computational Geometry Library for Parametric Aircraft Design," in *6th European Seminar on Computing (ESCO 2018)*, Pilsen, Tschechien, 2018.
- [15] M. Siggel, "TiGL (TiGL Geometry Library)," DLR, [Online]. Available: https://www.dlr.de/sc/en/desktopdefault.aspx/tabid-12766/22301_read-51485/. [Accessed August 2021].
- [16] D. S. Lazzara, R. Haimes and K. Willcox, "Multifidelity Geometry and Analysis in Aircraft Conceptual Design," in *19th AIAA Computational Fluid Dynamics*, San Antonio, Texas, 2009.
- [17] "OpenCASCADE document," OpenCASCADE, 13 August 2021. [Online]. Available: <https://dev.opencascade.org/doc/overview/html/index.html>. [Accessed August 2021].
- [18] F. Rauscher, J. Biedermann, C. Pätzold , F. Meller and B. Nagel, "Permanent Aktualisiertes 3D-Modell Der Realgeometrien Von Forschungsumgebungen," in *Deutscher Luft- und Raumfahrt Kongress*, 2021.
- [19] S. Herbst, "Development of an Aircraft Design Environment Using an Object-Oriented Data Model in MATLAB," PhD Technische Universität München, 2018.
- [20] J. -N. Walther, P. D. Ciampa and B. Nagel, "Disciplinary Implications Of A System Architecting Approach To Collaborative Aircraft Design," in *ECCOMAS Congress*, 2020.
- [21] "TiGL," DLR, 2020. [Online]. Available: <https://dlr-sc.github.io/tigl/>. [Accessed August 2021].