

Lawrence Berkeley National Laboratory

LBL Publications

Title

Coordinated microgrid investment and planning process considering the system operator

Permalink

<https://escholarship.org/uc/item/35k793t2>

Authors

Armendáriz, M
Heleno, M
Cardoso, G
[et al.](#)

Publication Date

2017-08-01

DOI

10.1016/j.apenergy.2017.05.076

Peer reviewed



Lawrence Berkeley National Laboratory

Coordinated Microgrid Investment and Planning Process Considering the System Operator

M. Armendariz^a, M. Heleno^b, G. Cardoso^b, S. Mashayekh^b, M. Stadler^{b,c}, L. Nordström^a

^a KTH Royal Institute of Technology, Osquindas väg 10, 7 tr, Stockholm, Sweden

^b Lawrence Berkeley National Lab, 1 Cyclotron Rd, Berkeley, CA 94720

^c Center for Energy and innovative Technologies (CET), Doberggasse 9, 3681 Hofamt Priel, Austria

To be published in Applied Energy

May 2017

Partial funding for this work was provided by the Office of Electricity Delivery and Energy Reliability, Distributed Energy Program of the U.S. Department of Energy under Contract No. DE-AC02-05CH11231.

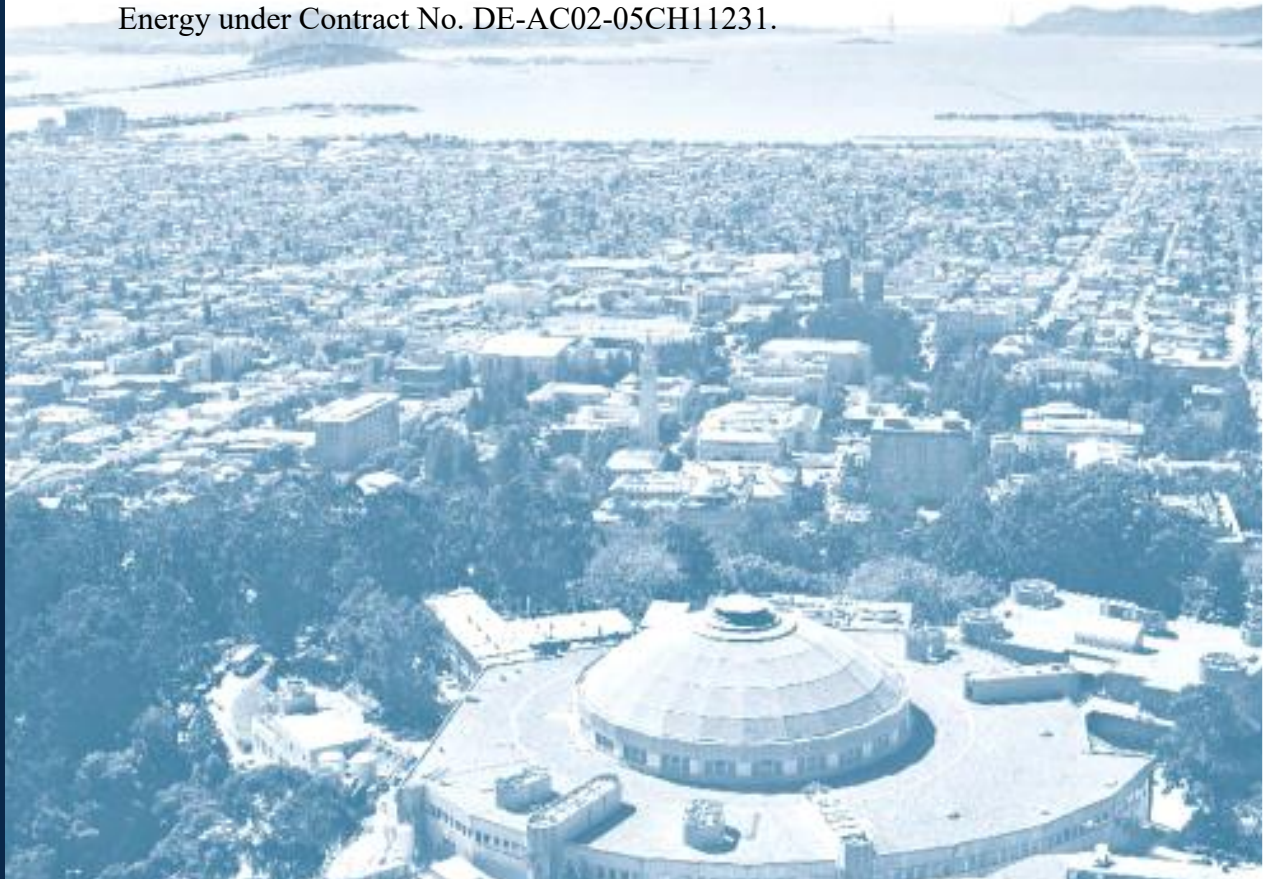

Disclaimer

This document was prepared as an account of work sponsored by the United States Government. While this document is believed to contain correct information, neither the United States Government nor any agency thereof, nor The Regents of the University of California, nor any of their employees, makes any warranty, express or implied, or assumes any legal responsibility for the accuracy, completeness, or usefulness of any information, apparatus, product, or process disclosed, or represents that its use would not infringe privately owned rights. Reference herein to any specific commercial product, process, or service by its trade name, trademark, manufacturer, or otherwise, does not necessarily constitute or imply its endorsement, recommendation, or favoring by the United States Government or any agency thereof, or The Regents of the University of California. The views and opinions of authors expressed herein do not necessarily state or reflect those of the United States Government or any agency thereof or The Regents of the University of California.

Coordinated Microgrid Investment and Planning Process Considering the System Operator

M. Armendariz^a, M. Heleno^b, G. Cardoso^b, S. Mashayekh^b, M. Stadler^b, L. Nordström^a

^aKTH Royal Institute of Technology, Osquldas väg 10, 7 tr, Stockholm, Sweden

^bErnest Orlando Lawrence Berkeley National Lab, 1 Cyclotron Rd, Berkeley, CA 94720

Corresponding Author: Mikel Armendariz (mikel@kth.se)

Abstract: Nowadays, a significant number of distribution systems are facing problems to accommodate more photovoltaic (PV) capacity, namely due to the overvoltages during the daylight periods. This has an impact on the private investments in distributed energy resources (DER), since it occurs exactly when the PV prices are becoming attractive, and the opportunity to an energy transition based on solar technologies is being wasted. In particular, this limitation of the networks is a barrier for larger consumers, such as commercial and public buildings, aiming at investing in PV capacity and start operating as microgrids connected to the MV network. To address this challenge, this paper presents a coordinated approach to the microgrid investment and planning problem, where the system operator and the microgrid owner collaborate to improve the voltage control capabilities of the distribution network, increasing the PV potential. The results prove that this collaboration has the benefit of increasing the value of the microgrid investments while improving the quality of service of the system and it should be considered in the future regulatory framework.

Keywords

Distribution grid voltage control, microgrid design, model predictive control, photovoltaics.

1. Introduction

The number of photovoltaic (PV) installations have exponentially increased over the last decades and a more accelerated growth, pulled by the emerging economies, is expected by 2020 [1]. This trend is driven by the falling prices of PV modules, e.g. between 2010 and 2020 the reduction of the average price of the PV systems is projected to be 75% [2]. Moreover, policy and regulatory measures have been incentivizing photovoltaic investments, such as Feed-in Tariffs (FiT) [3], which is a well-established policy to accelerate the renewable energy deployment into the grid. Authors in [4] outline the available FiT payment plans *i.e.*, *Percentage FiT*, *Fixed Price FiT* and *Premium FiT*. Examples of FiT schemes in

Europe are shown in [5] and in [6]. Other measures are capital subsidies for equipment purchase [7] as well as financial incentives and remuneration compensation schemes, such as self-consumption [8] , net-metering [9] and net-billing [10].

In addition, in order to maximize the on-site DER penetration it is a common practice to apply Demand Response (DR) procedures to decrease the load in peak hour conditions, demand curtailment and rescheduling in response to real-time market prices. A survey of DR potentials and benefits in smart grids is shown in [11] and in [12], where real industrial case studies and research projects are presented. In [13] a review is conducted focusing on real time market architectures and incentive policies for integrating DER (e.g., PV and wind energy) and DR in electricity markets of the North America, Australia and Europe. Authors claim that in the future such market architectures that integrate DER and DR will facilitate the asset utilization and thus they will contribute to maintain the security and the reliability of power systems.

This massive growth of DER installations, in particular PV, has brought new challenges to the operation of distribution systems. This is noticeable especially in Medium Voltage (MV) and Low Voltage (LV) networks, which are more vulnerable to the variations of the distributed generation. Several examples of the consequences brought by the large PV penetration in the distribution systems can be found in the literature [14]-[17]: voltage variations and unbalance, power congestion at the substation feeders, reverse power flows that can trip the protection relays affecting the grid reliability and islanding protection, etc.

A traditional solution to deal with these challenges is the active curtailment of the PV generation whenever it causes problems to the grid operation [18]. However, this procedure has been discouraged under the recent regulatory frameworks with the argument that curtailment is a threat to the investment in renewables and to the

accomplishment of emission targets [19]. Thus, the alternative solutions to PV curtailment are either regulatory or technical. On the regulatory side, self-consumption legislation has been approved in a significant number of countries [20]. Self-consumption policies aim at redesigning the PV remuneration tariffs to incentivize an adequate sizing of the PV installations and to promote the investment in behind-the-meter storage technologies [6], reducing the PV injection into the grid. On the technical side, several solutions to improve the supervision and control of the distribution grid to avoid the contingencies caused by the excess of PV generation have been proposed. An example of a supervision tool can be found in [21], where a probabilistic load flow method to quantify the over-voltages in a residential distribution network with high penetration of PV is presented. Also, a variety of design and control strategies to achieve operational security of distribution networks under scenarios of large PV penetration: grid-scale battery storage system design method to overcome voltage variations is presented in [22], an optimization method based on VAR compensation assisted with a communication infrastructure is proposed in [23], the coordination between static-VAR compensation and On Load Tap Changer (OLTC) are explored in [24] and the benefits of using Static Synchronous Compensator (STATCOM) for dynamic voltage regulation to avoid PV curtailments in peak situations is shown in [25].

These technical approaches to improve grid controllability proved to be very efficient in increasing the capabilities of distribution systems to host more PV capacity. However, they entail investment and operational costs to the distribution system operators (DSO) and, especially in scenarios of unbundling electricity sectors, DSOs have no interest in making those investments and bearing those costs. In fact, they have no motivation to enable more PV capacity, since their remuneration depends on electricity consumption and the

challenges of solar integration are mostly peak power related [19]. Moreover, the installation of photovoltaic units has the practical effect of reducing the net consumption of the prosumers, which decreases the income of the DSOs.

The difficulties of the system to accommodate more solar power persist in most distribution networks, especially those that already have a considerable number of photovoltaic installations connected to the LV network. This is a particular barrier for larger consumers, such as commercial and public buildings, aiming at investing in PV capacity and start operating as microgrids connected to the MV network (e.g., [26] and [27]). Three main reasons explain the limitations imposed by the distribution grids to the microgrids investment and planning process: 1) microgrids require a significant amount of PV to justify the investments and, since all the capacity is concentrated in the same node, it increases the risk for the system; 2) self-consumption policies are not an effective solution for typical commercial and public buildings microgrids, due to the severe variability of the load (e.g., consumption decreases dramatically during the weekends in office buildings or during the entire summer in schools), which requires unbearable investments in storage to avoid PV feed-in for several days in a row; 3) as discussed further on this paper, microgrids investment and planning is a complex process encompassing multiple energy vectors and technologies, which means that a constraint imposed to a technology (in this case to the PV) can dramatically change the energy mix, increasing the overall investment and operation costs.

Summarily, microgrid owners are interested in making significant investments in PV to decrease their energy costs, but this large amount of PV cannot be accommodated by the distribution system, unless new investments are made by DSOs, which have no economic

inventive to make them. Thus, this paper aims to respond to this impasse, by presenting an investment approach to the microgrids investment and planning process, where DSO and microgrid owners collaborate to improve the voltage control capabilities of the grid and increase the PV potential. An example of PV investments in a school, operated as a microgrid and connected to the MV network, is shown to illustrate the approach.

The contributions of this paper are the following: first, we propose a concerted approach, where the system operator and the microgrid owner cooperate in the investment process to increase the amount of PV capacity installed by the microgrid, without causing voltage problems to the distribution network; second, we demonstrate the advantages of involving the system operator in the microgrid investment and planning process in comparison with the standard isolated investment approach; third, we test and compare three voltage control strategies that increase the PV potential of the distribution network.

This paper is divided as follows: section 2 presents the conceptual approach towards a collaboration between the system operator and the microgrid owner in the investment and planning process and it discusses the main advantages and limitations; section 3 proposes technical solutions to enhance grid controllability so that the optimal solutions from the investment and planning process can be applied; section 4 presents a case study involving a realistic distribution network with a microgrid investment and finally section 5 presents the main conclusions of the paper.

2. Microgrid investment and planning: a coordinate approach

2.1. Microgrid Investment and Planning problem

Microgrid investment and planning is a complex problem that considers different energy generation and storage technologies and multiple energy vectors to supply energy loads,

typically while trying to minimize both capital and operational costs. Several tools can be found in literature to address this problem, such as REopt [28], RETScreen [29], SAM [30], HOMER [31] and DER-CAM (Distributed Energy Resources Customer Adoption Model) [32]. A comprehensive comparative study of tools for distributed generation projects is conducted in [33], where authors categorize the tools based on the type of use and capabilities, the addressed sector and the type of analysis (e.g., economic, energy-related or environmental analysis). These tools vary in data granularity (both in space and time), detail (linear vs non-linear), and solution method (optimization vs simulation). A discussion on the strengths and weaknesses found in each model type can be found in [34]. This work is supported by the use of DER-CAM, which addresses the electricity sector and fits the purpose of the study because it is valid to conduct economic and energetic analysis. The generic formulation of DER-CAM is described in (1)-(4).

$$\min. C = \sum_t InvC_t \cdot Ann_t + \sum_h \left(\sum_t UtilC_h + FOM_{t,h} + LMC_h - SR_h \right) \quad (1)$$

s.t.

$$GS_{t,h} + U_h - S_h = L_h + SC_{t,h} + LM_h \quad (2)$$

$$\underline{GS}_{t,h} \leq GS_{t,h} \leq \overline{GS}_{t,h} \quad (3)$$

$$F_h \leq \overline{F}_h \quad (4)$$

The objective function defined by C , considers DER investment costs given by $InvC_t \cdot Ann_t$, where Ann_t is an annuity rate to account for annual ownership costs and allow comparing t technologies with different lifetimes. Additionally, different operational costs are considered in the objective function, such as utility costs, $UtilC_h$, fuel and maintenance expenses associated with different DER, $FOM_{t,h}$, as well as costs related to load management decisions such as curtailments and DR events, LMC_h , and potential revenue from power exports, SR_h .

The key constraints are hourly (h) energy balances (2), generically stating that utility purchases (U_h), the dispatch of local generation and storage units ($GS_{t,h}$), and power exports (S_h), must balance energy loads (L_h), charging of storage units ($SC_{t,h}$), and load management events (LM_h). Other key constraints include the operational boundaries of DER, generically represented in equation (3), or the \overline{F}_h feed-in limit (4), which defines the maximum reverse electric power flow from the microgrid to the main distribution network. A detailed mathematical formulation of DER-CAM is presented in [35].

2.2. A coordinated approach for the microgrid investment and planning problem

Microgrids investment and planning optimization tools aim at supporting the investment decisions to be made exclusively by the microgrid owner. The solution that results from this optimization problem is a combination of technology investments and hourly dispatches that minimize the total costs of the microgrid owner. In non-isolated microgrids, the dispatch leads an hourly energy flow between the microgrid and the distribution network at the Point of Common Coupling (PCC). If significant investments in local generation are made by the microgrid owner, this flow can change the direction in some periods, becoming positive when the microgrid has a surplus of generation and power is fed into the grid. Therefore, in larger microgrid infrastructures where a more dramatic fluctuation is expected at the PCC power profile, a technical steady-state validation of the investments should be performed by the DSO, in order to ensure that the network can host the PCC profile without violating the normal operation of the distribution system. If the PCC profile generated by the optimal dispatch entails any risk to the distribution network operation, the microgrid investment solution is not feasible, since the dispatch and the investment problem cannot be separated. Therefore, the microgrid planning problem has to be solved again, narrowing

the feed-in limit constraint (4) that limits the power at PCC. This process is repeated until a feasible PCC power profile is found, as shown in Fig. 1a.

Obviously, after some iterations of this process, the technology mix found is a sub-optimal solution. In fact, the successive reductions of the PCC limits lead to higher costs and/or lower remuneration from the PV feed-in in comparison with the original infeasible solution. Also, it is important to stress that this loss of value is more severe when the distribution network already has a considerable number of photovoltaic installations and the voltages are near the upper limits, which reduces the new PV capacity to be installed by the microgrid.

Part of this limitation imposed by the distribution system to the microgrid planning problem can be solved with some investments on the network side, namely equipment that enhances the controllability and correct voltage violations when the PV injection is higher. However, from a regulatory perspective, this requires transforming the DSO in a participant agent in the microgrid investment and planning problem. Instead of simply accepting or rejecting the PCC power profile, the system operator may also evaluate some investments in new assets to enhance the controllability of the network, decreasing the constraints of the microgrid planning problem. These new assets will leverage the PV investments and increase the microgrid economic gains.

Thus, the rationale behind the approach presented in this paper, where a coordination of the investments between DSO and microgrid owner, is based on the assumption that the economic value of removing part of the grid constraints to the microgrid planning problem is higher than the costs of the investments in these new assets. Therefore, the Capital Expenditures (CAPEX) and Operational Expenditures (OPEX) associated with these new

assets can be totally or partially allocated to the microgrid owner, e.g. by reducing the feed-in prices or by including an annual fee that covers the lifecycle cost of the investments, as shown in Fig. 1b. This cost is defined in (5).

$$Cost_{Ann. DSO investment} = Cost_{Annual ctrl. OPEX} + Cost_{Annualized ctrl. CAPEX} \quad (5)$$

Although this approach is valid for any kind of DSO investments that increase the capabilities of hosting more PV, in this paper we are exploring the investment and operation costs of OLTC both in MV/LV and MV/LV transformers, using the optimal strategies presented in section 3. Hence, CAPEX captures the expenses required for acquiring or upgrading the OLTC actuators to perform voltage control and the OPEX captures the running costs such as maintenance and OLTC operation. In this paper we assign the OPEX to be dependent of the tap change operations where each tap change corresponds to 4.81 cents \$/tap-change [42].

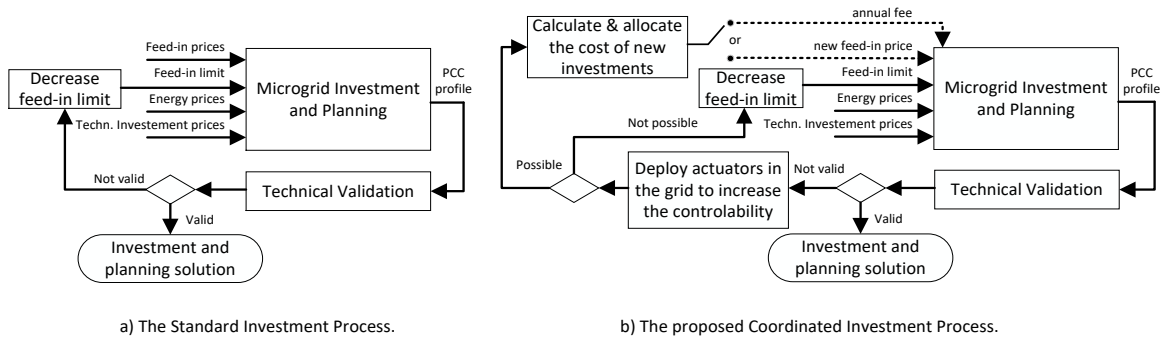

Fig. 1. a) The Standard Investment Process. b) The proposed Coordinated Investment Process.

3. Proposed technical solutions to enhance grid controllability

Under the coordinated approach presented above, the DSO should evaluate potential investments in new assets that can increase the PV hosting capacity and, consequently, the remuneration of the microgrid. In this paper, investments in OLTC assets are considered to enhance the controllability of the distribution network. Three voltage control strategies,

encompassing the investment and operation of OLTC equipment by the DSO, are presented. In addition, a passive strategy based on the PV capacity curtailment is also tested for comparison purposes. The voltage control strategies considered in this study follow a hands-off policy that is aligned with the electricity unbundling in EU. Thus, in this study, we assume not to be dependent of 3rd parties to operate the distribution grid as it could be to interact with the end customer to perform inverter control in all its varieties, e.g. PF(P), Q(V). Therefore, only assets own and controllable by the utility are considered, more specifically OLTCs at MV and LV substations.

3.1. Description of the control strategies

The first control strategy corresponds to the business as usual and it is named as *CS-A*. It is the most common situation and it consists of manipulating only the OLTC connected to the power transformer at the MV substation. This strategy assumes no OLTC actuators connected to the transformers at the LV substations that spread out from the MV substation. Therefore, there is only one variable to be manipulated in this control strategy: the tap position at the MV substation. The second control strategy corresponds to the problematic feeder control, named as *CS-B*, which consists of manipulating the OLTC actuator deployed at the LV substations that experience overvoltages. The third strategy corresponds to the compensation strategy, named as *CS-C*, which consists of manipulating two types of actuators: first, the OLTC at the MV substation, as in *CS-A*. Second, the OLTC actuator deployed at the LV substations that do not experience overvoltages and can experience undervoltages as a side effect of manipulating the OLTC at the MV substation.

The control strategies are formulated as a Model Predictive Control (MPC), since it allows controlling both the voltage quality and the OLTC switching operations by employing simple

linear models of the electrical grid. For the sake of result comparison, these control strategies are also compared to the PV capacity curtailment.

3.2. MPC architecture

The MPC architecture is shown in Fig 2. The controlled plant corresponds to the MV-LV distribution grid, which is formed by an n number of LV Secondary Substations (SS) that are connected to a primary MV distribution substation (HV/MV) following a radial topology. Similarly, each of the LV secondary substations is spread out on a radial topology providing electricity to a group of households.

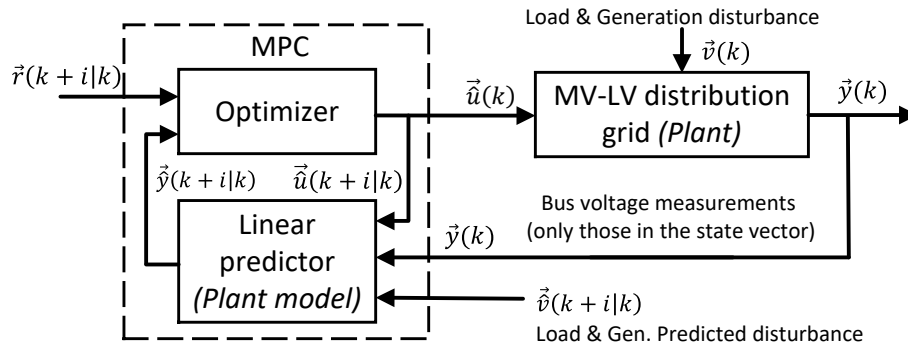

Fig 2. MPC-based control architecture.

The bus voltage reference trajectories are defined by the vector \vec{r} and are set to $1pu$. These reference trajectories can be dynamically imposed by a Supervisory Control and Data Acquisition - Distribution Management System (SCADA-DMS) that operates the MV-LV grid. The measurements correspond to the controlled signals of the physical process and represent the bus voltages at the LV distribution network; these are defined by the vector \vec{y} and are assumed to be obtained by the Automatic Meter Reading (AMR) infrastructure. The objective of the control architecture is to obtain a sequence for the tap positions (*i.e.*, the manipulated variables) defined by the \vec{u} vector so that the \vec{y} vector follows the \vec{r} vector.

The state-space representation of the plant's model is defined in (6) and the details of how to obtain the A , B_u and B_v matrices can be found in previous works presented in [36] and in [37].

$$\vec{\hat{x}}(k+i+1) = A \cdot \vec{\hat{x}}(k+i) + B_u \cdot \vec{\hat{u}}(k+i) + B_v \cdot \vec{\hat{v}}(k+i) \quad (67a)$$

$$\vec{\hat{y}}(k+i) = \vec{\hat{x}}(k+i) \quad (67b)$$

$$\vec{\hat{x}}(k) = \vec{\hat{x}}(k|k) = \vec{y}(k) \quad (67c)$$

The disturbance applied to the controlled plant is defined by the \vec{v} vector and it represents the active and reactive power increments in the LV grid caused by the load and the PV generation units. The estimated measured disturbance represents the predicted values for \vec{v} and it is defined by the $\vec{\hat{v}}$ vector. These predictions can be obtained from a load and a PV generation forecaster that yields the prediction values for a p -prediction horizon using weather data such as outdoor temperature, solar radiation and wind speed, as presented in [39]. The optimization problem is formulated as a receding horizon-based Mixed Integer Quadratic Programming (MIQP) model [38], where the objective is to minimize the cost function defined by $J(\vec{z}_k)$ over a period of 24h, as defined in (7). Subject to the constraints defined in (8) and (9), which set the requirements for the voltage level and the OLTC's tap operations. The decision vector \vec{z}_k is defined in (10).

$$\begin{aligned} \min. J(\vec{z}_k) = & \sum_{j=1}^{n_y} \sum_{i=1}^p \{w_{i,j}^y [r_j(k+i|k) - \hat{y}_j(k+i|k)]\}^2 + \\ & + \sum_{j=1}^{n_u} \sum_{i=0}^{p-1} \{w_{i,j}^u [\hat{u}_j(k+i|k) - \hat{u}_j(k+i-1|k)]\}^2 + \rho_\varepsilon \varepsilon_k^2 \end{aligned} \quad (7)$$

s.t.

$$\underline{y}_j(i) - \varepsilon_k \cdot \underline{V}_j^y(i) \leq \hat{y}_j(k+i|k), \quad i = 1:p, \quad j = 1:n_y \quad (8a)$$

$$\overline{y}_j(i) + \varepsilon_k \cdot \overline{V}_j^y(i) \geq \hat{y}_j(k + i|k), i = 1:p, j = 1:n_y \quad (8b)$$

$$\overline{u}_j(i) \leq \hat{u}_j(k + i - 1|k) \leq \overline{u}_j(i), i = 1:p, j = 1:n_u \quad (9a)$$

$$\underline{\Delta u}_j(i) \leq \Delta \hat{u}_j(k + i - 1|k) \leq \overline{\Delta u}_j(i), i = 1:p, j = 1:n_u \quad (9b)$$

$$\sum_{i=1}^p |\Delta \hat{u}_j(k)| \leq \text{MADSON}, j = 1:n_u \quad (9c)$$

Where the decision vector is:

$$\vec{z}_k = [\hat{u}(k|k) \hat{u}(k + 1|k) \cdots \hat{u}(k + p - 1|k) \varepsilon_k]^T \quad (10)$$

k is the current interval; p is the prediction horizon; ε_k is the slack variable at control interval k ; ρ_ε is the constraint violation penalty weight; n_y is the number of output variables; n_u is the number of manipulated variables; $r_j(k + i|k)$ is the reference for j^{th} plant's controlled signal at i^{th} prediction horizon step; $\hat{y}_j(k + i|k)$ is the prediction of j^{th} plant's controlled signal at i^{th} prediction horizon step; $w_{i,j}^y$ is the penalty weight for j^{th} plant's controlled signal at i^{th} prediction horizon step; $w_{i,j}^{\Delta u}$ is the penalty weight for j^{th} manipulated variable increment at i^{th} prediction horizon step; $\underline{y}_j(i)$ and $\overline{y}_j(i)$ are the lower and the upper bounds for j^{th} plant's controlled signal at i^{th} prediction horizon step; $\underline{u}_j(i)$ and $\overline{u}_j(i)$ are the lower and the upper bounds for j^{th} plant's manipulated variable at i^{th} prediction horizon step; $\underline{\Delta u}_j(i)$ and $\overline{\Delta u}_j(i)$ are the lower and the upper bounds for j^{th} plant's manipulated variable increment at i^{th} prediction horizon step; $\underline{V}_j^y(i)$ and $\overline{V}_j^y(i)$ are the lower and the upper bounds for soft constraints tuning factor; MADSON is the Maximum Allowable Daily Switching Operations.

4. The benefits of a coordinated approach: case study

This chapter presents a realistic case study to illustrate the coordinated microgrid investment approach discussed above. The PV investments in a school, with average

dimensions in terms of load consumption, operating as a microgrid and connected to the distribution network, are analyzed. Two investment approaches are used in this analysis in addition to the reference case:

- *Reference case*: The situation before the DER investments in the school.
- *Standard investment approach*: The DER investment in the school using the standard microgrid investment and planning tool, where the role of the DSO consists of accepting or rejecting the profile at PCC.
- *Coordinated investment approach*: The DER investments in the school using the approach proposed in this paper, where the DSO actively participates in the process by evaluating new possibilities of enhancing the distribution grid controllability, allowing more PV capacity in the school.

At the end, the costs associated with each investment approach are quantified in order to evaluate the economic performance of the collaborative investment approach presented in this study. In addition, the technical performance of each investment approach is also assessed.

4.1. Case Setup and Input Data

The electric network considered in this case study, shown in Fig. 3, is a typical MV-LV distribution grid composed by two long feeders connected to a HV/MV distribution substation. The node SS1 is a heavily loaded substation consuming 5GWh/year and with a peak power of 1457kW in winter periods. The nodes SS2 and SS3 are two secondary substations feeding two residential neighborhoods, whose topology is based on the IEEE European LV Test Feeder [40]. The residential area under SS3 is composed by 55 modern buildings equipped with rooftop PV systems, causing reverse power flows at noon,

especially in the summer when the reverse power flow peak is 190kW. In contrast, no significant photovoltaic penetration exists in the old buildings of SS2, where the peak electricity consumption, 180kW, occurs during the winter. Lastly, a school serving this area is connected to the SS4 secondary substation. Here is where a private microgrid is deployed and the PV investments are made.

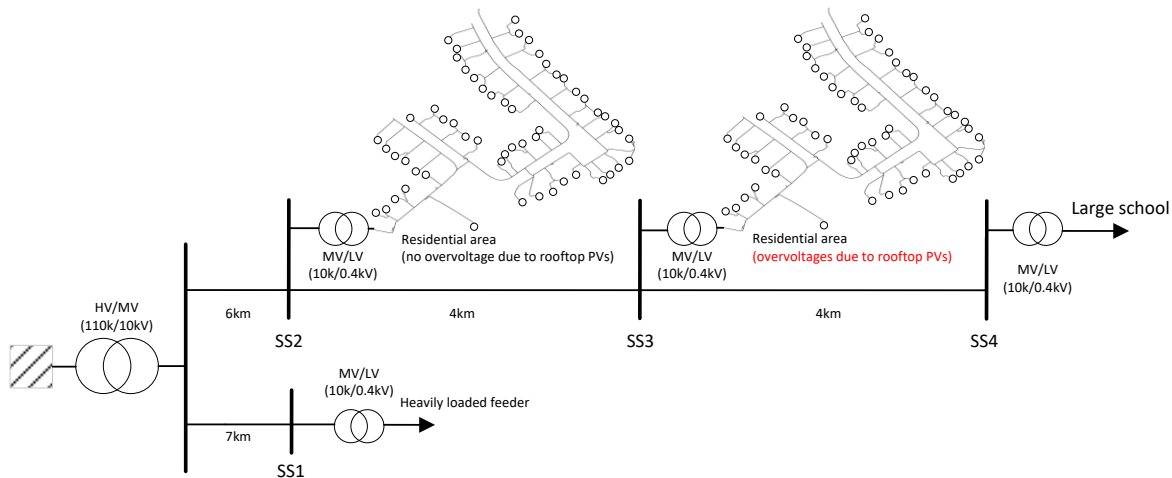

Fig. 3. The single-line diagram of the electric distribution grid case study.

4.2. Reference case

In the reference case, the PCC profile at node SS4 corresponds to the school load before the DER investments. The school has a consumption of 600MWh/year with 220kW of peak happening in winter. A time-of-use (TOU) tariff based on three periods (peak, shoulder and off-peak) is applied to the electricity consumption of the school. Table 1 presents the electricity prices in each period that are based on the PG&E E-19V tariff [41]. These prices lead to a total annual energy costs of 149.1 k\$ and this is considered as the reference case for the analysis of this case study.

Table 1

Electricity rates [\$/kWh].

Peak	Shoulder	Off-peak
0.16	0.10	0.08

In the reference case, the PCC profile of the school does not cause any voltage problem to the distribution network. However, due to the significant PV already installed in the residential neighborhood connected to SS3, this LV node is close to reach the upper voltage limit. Fig. 4 shows the 24h voltage profile during weekdays and weekends in the four seasons of the year. As shown in the figure, the voltage increases during daylight hours, especially in spring where the peak occurs. The voltage in weekends is higher than in weekdays, due to the consumption decrease in the school, located in a close node (SS4).

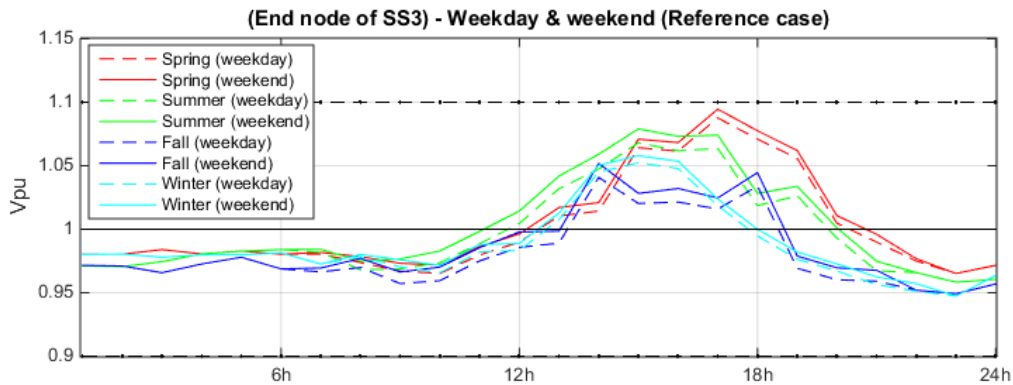

Fig. 4. Voltage profiles at the critical feeder in the reference case. The voltage limits are set to 1.1 pu and 0.9 pu, which correspond to $U_n \pm 10\%$, with $U_n = 230$ V.

4.3. Standard investment approach

In the *standard investment approach* we assume that PV generation and storage capacity are added to the school microgrid, located in node SS4, due to the investments done by the microgrid owner. The microgrid design is performed by the DER-CAM optimization model. This solution is obtained by solving a MILP, where the objective is to maximize the economic savings by installing the mix of DER technologies: PV and battery capacity. This DER

configuration represents an unrestricted, or ideal, microgrid design, because the resulting feed-in power into the grid is disregarded. The rationale on adding the PV generation and battery installations is that in this new situation part of the generated surplus energy from the PV panels can be stored in the battery and be used later on when the school's consumption demand turns higher than the onsite generated energy production. This way the microgrid can reduce the energy import from the grid. Moreover, a FiT mechanism is assumed, which incentivizes energy exports into the distribution grid depending on the load profile, the generated power profile and the available energy in the battery. In this investment approach, the optimal unrestricted DER capacity values are reduced so that the feed-in power profile at the PCC does not generate overvoltages in the grid and therefore, does not jeopardize the distribution network operations.

The investment cost is defined by (11) and the PV system and battery data regarding variable cost, fixed maintenance and the assumed lifetime of the PV system are shown in Table 2. This information is very relevant because together with the feed-in price, which is assumed uniform in this study (0.1 \$/kWh), they determine the viability and the installed PV generation and battery storage capacities.

$$Cost_{Inv.} = Cost_{Fixed} + Cost_{Variable} \quad (11)$$

Table 2

Photovoltaic and battery data.

Technology	Variable cost (\$/kW or \$/kWh)	Fixed maintenance (\$/kW per month)	Lifetime (years)
PV	2800	0.25	30
Battery	400	0	10

The considered investment period corresponds to 20 years, the maximum payback period is limited to 10 years and an interest rate of 5% was assumed. The optimal investment

solution resulting from these conditions can generate a feed-in peak power of 506kWp and the resulting PCC profile has an impact on the voltage of the critical feeder (i.e., the end node of SS3 as it is the part in the grid where the highest overvoltages are observed). Fig. 5 shows the 24h voltage profile at the end of SS3 for different seasons and type of days. It can be seen that overvoltages occur during spring and summer periods, which results in this DER investment solution obtained by the *unrestricted design* not being feasible.

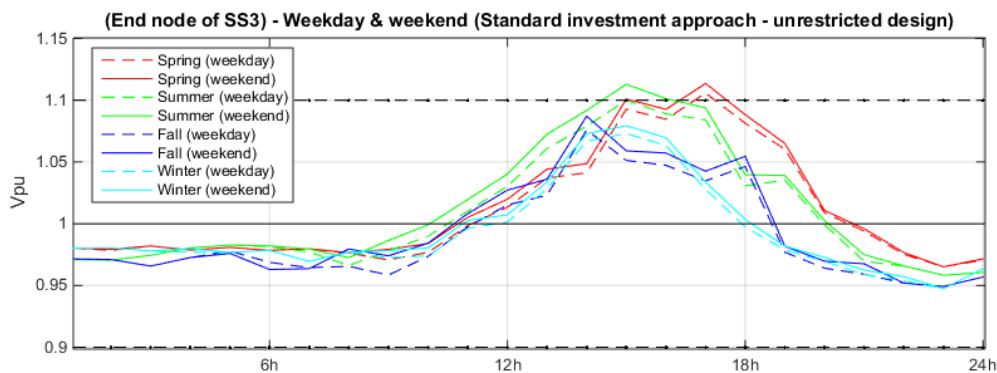

Fig. 5. 24h voltage profile at the end of SS3 for different seasons and type of days for the standard investment approach – unrestricted design.

Therefore, under the standard microgrid investment approach, the feed-in power of the school should be successively narrowed until a feasible investment solution is found. The result of this iterative process of constraining the microgrid investment and planning is a significant decrease of the PV capacity of the school and a small increase of the battery size, which allow the feed-in power to reduce from 506 kWp to 101 kWp and keep the system stable. However, this restricted solution has a lower economic value for the school owner: the energy savings decrease and annualized energy cost increase in comparison with the ideal (unrestricted) investment solution. Table 3 summarizes the solutions for the unrestricted and restricted microgrid designs.

Table 3

Optimal PV and battery capacity solution corresponding to the standard microgrid designs.

Standard microgrid design type	PV capacity (kW)	Size of PV (m ²)	Battery capacity (kWh)	PV export (kWp)	Energy cost (k\$/year)	Energy savings (k\$/year)
Unrestricted	610	3993	268	506	92.9	56.2 (37.7%)
Restricted	343	2241	320	101	106.6	42.5 (28.5%)

4.4. Coordinated investment approach

In the proposed coordinated investment approach besides the DER investments in the school by the microgrid owner, the DSO also evaluates new investments in OLTCs to upgrade the grid controllability. This controllability improvement avoids the overvoltages caused by the unrestricted microgrid design. If these costs are assumed by the microgrid owner, the total coordinated design cost results in (12). Instead, if the costs are covered by the system operator, the total cost for the microgrid owner remains as in the *standard investment approach - unrestricted design*.

$$Cost_{\text{Coordinated design}} = Cost_{\text{Standard investment-unrest. design}} + Cost_{\text{Ann. ctrl. inv.}} \quad (12)$$

(Ctrl. cost by μ Grid)

In Table 4 the design costs for the microgrid owner are compared. It can be seen that the design with highest costs corresponds to the standard design, which requires curtailment of installation capacity, followed by the coordinated design with the controllability upgrading costs covered by the microgrid owner. Finally, the lowest costs correspond to the coordinated design with the controllability upgrading costs covered by the DSO. From this table one can see the potential savings that can be obtained if there is collaboration between the system operator and the microgrid owner. Besides, from the microgrid owner point of view, the deployment and operation of the required controllability technology is

economically motivated regardless who covers the expenses. Anyhow, if the DSO covers these costs the energy savings are obviously larger. The reason here is that the feed-in remuneration can cover the controllability costs and that remuneration turns larger with the coordinated design than with the standard design. The *CS-A* control strategy only allows the 70% of the feed-in peak power (354 kWp) obtained by the unrestricted design without forcing overvoltages in the grid. This requires reducing the installed generation and storage capacity to 579 kW and 363 kWh respectively. And consequently, the resulting savings turn smaller than the obtained by applying the *CS-B* or the *CS-C*. Yet, *CS-A* achieves bigger savings than the standard investment approach.

In any case, the microgrid owner would be benefited from the deployment of assets because it would still reach energy savings even though it paid part of the controllability costs. Nevertheless, assuming the facts that additional PV installations are installed on the feeder and that the network is already close to the voltage limits, the controllability costs could be prorated among these installations. The reason is that it is not only the responsibility of the marginal new PV installation to cover all the costs because the other installations will also contribute to the overvoltages.

In order to maximize the energy savings, the microgrid owner would be in favor of the lowest cost control strategy to be deployed and that would be the *CS-B*. Similarly, that would also be the control strategy that looks best in terms of costs if the DSO covered part of the deployment charges. However, as it will be shown next in section 4.5, this asset deployment strategy simply fits the purpose of allowing the microgrid to be integrated into the grid but it does not provide voltage profile improvement support.

Table 4

Microgrid investment cost comparison

Microgrid investment	Energy cost (k\$/year)	Controllability cost		Total cost (k\$/year)	Energy savings (%)
		CAPEX (k\$/20year)	OPEX (k\$/year)		
Reference case	149.10	-	-	149.10	-
Standard investment approach (restricted)	106.60	-	-	106.60	28.50
Coordinated investment approach: controllability cost by microgrid owner					
CS-A	96.00	0.6	0.21	96.81	35.07
CS-B	92.90	0.3	0.07	93.27	37.45
CS-C	92.90	0.9	0.35	94.15	36.86
Coordinated investment approach: controllability cost by DSO					
CS-A	96.00	-	-	96.00	35.60
CS-B	92.90	-	-	92.90	37.70
CS-C	92.90	-	-	92.90	37.70

4.5. Voltage quality improvement of the distribution grid

In this section the performance of the microgrid designs are evaluated in terms of the voltage quality improvement of the distribution grid. This metric represents how well the controllability upgrade contributes to the voltage profile flattening of the rest of the nodes that form the distribution grid. This indicator is defined by (13) and (14) and it indicates the root-mean-square error between each of the measured bus voltages and its reference voltage for a period of 24 hours. This calculation is performed for all the control strategies and it is normalized to the $RMSE_{grid}$ obtained when the reference case is applied. Thus, the RMSE % reduction is computed as defined by (15). The results are summarized in Table 5.

$$RMSE_{bus} = \sqrt{\frac{\sum_{k=0}^{23} (1 - voltage(k))^2}{24}} \quad (13)$$

$$RMSE_{grid} = mean(RMSE_{bus}) \quad (14)$$

$$RMSE \% reduction = \frac{RMSE_{grid: reference case} - RMSE_{grid: CS-A/B/C}}{RMSE_{grid: reference case}} \cdot 100 \quad (15)$$

Table 5

Voltage quality Vs. Controllability cost for each microgrid design.

Microgrid investment	RMSE (%) reduction in 24h (avg. year)	Location of OLTCs	Controllability cost Total (k\$/year)
Reference case - No control	0	-	-
Standard investment approach			
Unrestricted design - No control	-12	-	-
Restricted design - Curtailment	0	-	-
Coordinated investment approach			
CS-A	15	HV/MV	0.81
CS-B	-2	SS3	0.37
CS-C	16	HV/MV, SS1	1.25

The strategy that achieves the best RMSE % reduction considering the entire network corresponds to the *CS-C*, followed by the *CS-A* and then by the *CS-B*. The reason is that both *CS-C* and *CS-A* use the OLTC at the HV/MV transformer, thus affecting the full network. Besides, *CS-C* reaches better quality results due to the combination of HV/MV and MV/LV OLTC control, the former to remove the overvoltages and to improve the voltage quality, and the latter to compensate the undervoltages forced by the former. The *CS-B* shows small negative RMSE % reduction even though the control is applied and the overvoltages are removed. This is due to the penetration of PV increases the voltage level at adjacent nodes of the network and the *CS-B* only focuses on the problematic feeder disregarding the rest of

the network. All in all, it is important to analyze the fact that it is possible to remove the overvoltages only by focusing on the problematic feeder. However, if in addition to removing the overvoltages we also expect to improve the voltage profile of the rest of the network, the studied solutions require adding extra OLTCs with the corresponding costs. Fig. 6 shows that the tested control strategies can remove the overvoltages and especially the *CS-C* and the *CS-B* outperform the rest in terms of voltage profile flattening at the problematic node.

Therefore, if the DSO covered part of the costs it seems a better option to choose the *CS-C* because it would allow maximizing the microgrid's energy savings in addition to improving the voltage profile and thus preventing future overvoltage problems in other parts of the grid.

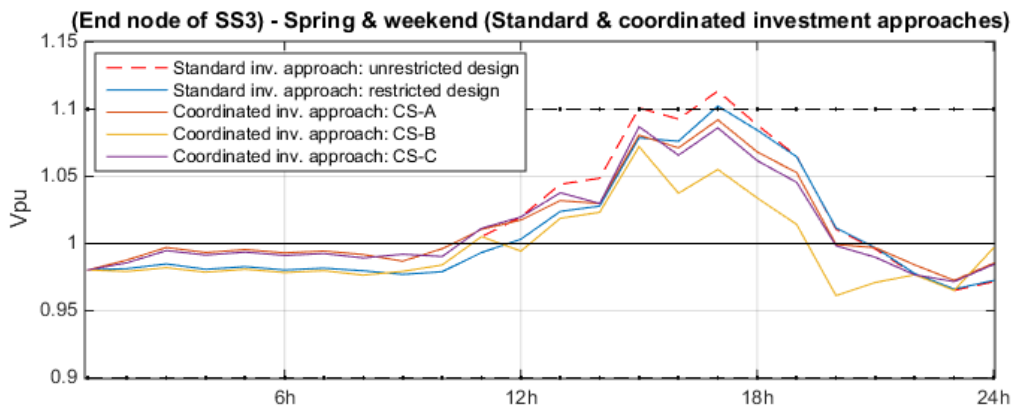

Fig. 6. 24h voltage profile at the end of SS3 for the standard and coordinated investments approaches.

5. Conclusion

In this paper we propose a concerted microgrid investment approach where the system operator and microgrid owner cooperate in order to increase the amount of PV capacity installed by microgrid without causing voltage problems to the distribution network. The common regulatory rules only require the DSO to accept or to reject the PV installations. However, the microgrid owner would be in favor of collaborating with the DSO by deploying assets to increase the controllability and to allow larger PV capacity installations, so that the

disturbances caused by the photovoltaic injection can be handled. Thus, the energy savings can be increased without violating the normal operation of the distribution system. Therefore, the microgrid owner is incentivized to pay the deployment because it will still achieve energy savings. This collaboration is illustrated by a case study, where the coordinated and the standard microgrid investments are compared. The results show that the coordinated planning process is economic viable for the microgrid owner and that the voltage profile is improved with its corresponding increased hosting capacity for the distribution grid. Therefore, we can conclude that even if all the costs were allocated to the microgrid (worst case scenario); the coordinated process would still be a better solution than the current situation (passive role of DSO) for both actors: microgrid owner and DSO.

We highlight the fact that the activities related to upgrading the grid controllability are performed by the system operator and these could be financed by the microgrid owner or even by prorating the costs among the additional PV installations that are installed on the feeder.

From a regulatory perspective, two approaches can be used to allow this collaboration: either by incrementing the energy tariff considering the annualized lifecycle cost of the investments or by applying a reduction to the PV feed-in price remuneration.

Finally, the controllability assets can be deployed to simply remove the overvoltages only by acting on the problematic feeder that hosts the problems. Or additionally, extra assets can be deployed, so that the voltage quality of the rest of the network can be improved. Hence, according to the obtained results the CS-C or compensation strategy seems to be the strategy that fits best the microgrid's and the grid operator's objectives, energy savings and voltage profile improvement in the distribution grid.

Further research work will focus on developing and proposing methods to share the costs among the prosumers responsible for the network violations.

6. Acknowledgment

We thank the anonymous reviewers who provided helpful suggestions on earlier drafts of the manuscript. This work is supported by the Swedish Centre for Smart Grids and Energy Storage (SweGRIDS).

7. References

- [1] International Energy Agency (2014). "Technology Roadmap: Solar Photovoltaic Energy" (PDF). [Online]. Available: <http://www.iea.org>. IEA.
- [2] U.S. Department of Energy (DOE). (2012). SunShot Vision Study. DOE/GO-102012-3037. Washington, D.C.: DOE. [Online]. Available: <http://www1.eere.energy.gov/solar/pdfs/47927.pdf>.
- [3] Policymaker's Guide to Feed-in Tariff Policy Design Couture, T., Cory, K., Kreycik, C., Williams, E., (2010). National Renewable Energy Laboratory, U.S. Dept. of Energy.
- [4] Pyrgou, A., Kylili, A., and Fokaides, P. A. "The future of the Feed-in Tariff (FiT) scheme in Europe: The case of photovoltaics." *Energy Policy* 95 (2016): 94-102.
- [5] Antonelli, M., & Desideri, U. "Do feed-in tariffs drive PV cost or viceversa?" *Applied Energy* (2014). Vol. 135, pp. 721-729.
- [6] Brusco, G, et al. "The economic viability of a feed-in tariff scheme that solely rewards self-consumption to promote the use of integrated photovoltaic battery systems." *Applied Energy* 183 (2016): 1075-1085.
- [7] Lindahl, Johan. "National Survey report of PV Power Applications in Sweden 2014." Ångström Solar Center, Uppsala University, Uppsala (2014).
- [8] Luthander, R., et al. "Photovoltaic self-consumption in buildings: A review." *Applied Energy* 142 (2015), pp. 80-94.
- [9] Ratnam, E. L., Weller, S. R. and Kellett, C. M. "Scheduling residential battery storage with solar PV: Assessing the benefits of net metering." *Applied Energy* 155 (2015), pp. 881-891.
- [10] L. Behrendt (2015). Taxes and incentives for renewable energy. KPMG. [Online]. Available: <https://assets.kpmg.com/content/dam/kpmg/pdf/2015/09/taxes-and-incentives-2015-web-v2.pdf>.
- [11] Siano, P. "Demand response and smart grids—A survey." *Renewable and Sustainable Energy Reviews* 30 (2014), pp. 461-478.
- [12] Aghaei, J., and Alizadeh, M.I. "Demand response in smart electricity grids equipped with renewable energy sources: A review." *Renewable and Sustainable Energy Reviews* 18 (2013), pp. 64-72.
- [13] Wang, Qi, et al. "Review of real-time electricity markets for integrating distributed energy resources and demand response." *Applied Energy* 138 (2015), pp. 695-706.
- [14] Karimi, M., et al. "Photovoltaic penetration issues and impacts in distribution network—A review." *Renewable and Sustainable Energy Reviews* 53 (2016): pp. 594-605.

- [15] Trichakis, P., et al. "Predicting the technical impacts of high levels of small-scale embedded generators on low-voltage networks." *Renewable Power Generation, IET* 2.4 (2008): pp. 249-262.
- [16] Katiraei, Farid, and Julio Romero Agüero. "Solar PV integration challenges." *Power and Energy Magazine, IEEE* 9.3 (2011): pp. 62-71.
- [17] Awadallah, Mohamed A., et al. "On the Effects of Solar Panels on Distribution Transformers." *IEEE Transactions on Power Delivery* 31.3 (2016): pp. 1176-1185.
- [18] Reinaldo Tonkoski, Luiz A.C. Lopes, "Impact of active power curtailment on overvoltage prevention and energy production of PV inverters connected to low voltage residential feeders", *Renewable Energy*, Vol. 36, Issue 12, December 2011, pp. 3566-3574.
- [19] PV Grid, "European Advisory Paper", July 2014. [Online]. Available: http://www.pvgrid.eu/fileadmin/PVgrid_AdvisPaper.pdf
- [20] Masson, G.; Briano, J. I.; Baez, M. J., "Review and Analysis of PV Self-consumption", International Energy Agency - Photovoltaic Power Systems Programme (Report IEA-PVPS T1-28:2016), 2016.
- [21] M.N. Kabir, Y. Mishra, R.C. Bansal, "Probabilistic load flow for distribution systems with uncertain PV generation", *Applied Energy*, Vol.163, 1 February 2016, pp. 343-351.
- [22] C. A. Hill, et al., "Battery Energy Storage for Enabling Integration of Distributed Solar Power Generation", *IEEE Trans. on Smart Grid*, Vol. 3, no. 2, pp. 850-857, June 2012.
- [23] L. Leite, et al., "Integrated voltage regulation in distribution grids with photovoltaic distribution generation assisted by telecommunication infrastructure", *Electric Power Systems Research*, Vol. 136, July 2016, pp. 110-124
- [24] N. Daratha, B. Das and J. Sharma, "Coordination Between OLTC and SVC for Voltage Regulation in Unbalanced Distribution System Distributed Generation", *IEEE Transactions on Power Systems*, Vol. 29, no. 1, pp. 289-299, Jan. 2014.
- [25] C. S. Chen, et al., "Enhancement of PV Penetration With DSTATCOM in Taipower Distribution System", *IEEE Trans. on Power Syst.*, Vol. 28, no. 2, pp.1560-1567, May 2013.
- [26] K. Nam et al., "Establishment of a pilot plant for KERI microgrid system based on power IT development program in Korea," *2009 Transmission & Distribution Conference & Exposition: Asia and Pacific*, Seoul, 2009, pp. 1-6.
- [27] P. Sreedharan, et al., "Microgrid and renewable generation integration: University of California, San Diego", *Applied Energy*, Volume 169, 1 May 2016, Pages 709-720.
- [28] Simpkins, T., et al. "REopt: a platform for energy system integration and optimization." ASME 2014 8th International Conference on Energy Sustainability collocated with the ASME 2014 12th International Conference on Fuel Cell Science, *Engineering and Technology. American Society of Mechanical Engineers*, 2014.
- [29] The RETScreen Clean Energy Project Analysis Software 4.0, Natural Resources Canada–Canmet ENERGY, The RETScreen International Clean Energy Decision Support Centre, 580 Booth Street, 13th floor Ottawa, Ontario, K1A 0E4, Canada, [Online]. Available: <http://www.etscreen.net/ang/centre.php>.
- [30] Blair, Nate, et al. "System advisor model, sam 2014.1. 14: General description." Nat. Renew. Energy Lab., Denver, CO, USA, Tech. Rep. NREL/TP-6A20-61019 (2014).
- [31] Lilienthal, Peter, P. Gilman, and T. Lambert. HOMER® micropower optimization model. United States. Department of Energy, 2005.
- [32] G. Cardoso, M. Stadler, M. C. Bozchalui, R. Sharma, C. Marnay, A. Barbosa-Póvoa, and P. Ferrão, "Optimal investment and scheduling of distributed energy resources with uncertainty in electric vehicle driving schedules," *Energy*, Vol. 64, pp. 17-30, 2014.
- [33] Massimiliano, M., Caputo, P. and Costa, G. "Paradigm shift in urban energy systems through distributed generation: Methods and models." *Applied Energy* 88.4 (2011), pp. 1032-1048.

- [34] T. Schittekatte, M. Stadler, G. Cardoso, S. Mashayekh, N. Sankar, "The impact of short-term stochastic variability in solar irradiance on optimal microgrid design," *IEEE Transactions on Smart Grid*, Vol. 99, pp.1-1, Aug 2016.
- [35] S. Mashayekh, M. Stadler, G. Cardoso, M. Heleno, "A mixed integer linear programming approach for optimal DER portfolio, sizing, and placement in multi-energy microgrids", *Applied Energy*, Vol. 187, pp. 154-168, February 2017.
- [36] Brenna, Morris, et al. "Automatic distributed voltage control algorithm in smart grids applications." *IEEE Transactions on Smart Grid*, vol. 4.2 (2013): pp. 877-885.
- [37] M. Armendariz, D. Babazadeh, D. Brodén, L. Nordström, "Strategies to Improve the Voltage Quality in Active Low-Voltage Distribution Networks Using DSO's Assets", *IET Generation, Transmission & Distribution*, pp. 9, September 2016.
- [38] Allgower, Frank, Alex Zheng. Nonlinear model predictive control. Birkhauser, 2000.
- [39] Zong, Yi, et al. "Model predictive controller for active demand side management with pv self-consumption in an intelligent building." *ISGT Europe*, Berlin, 2012.
- [40] IEEE PES Distribution Systems Analysis Subcommittee Radial Test Feeders [Online]: <http://ewh.ieee.org/soc/pes/dsacom/testfeeders>.
- [41] PG&E Tariffs [Online]. Available: www.pge.com/tariffs/tm2/pdf/ELEC_SCHEDS_E-19.pdf.
- [42] Daniele Clerici, et al. "Advanced Tools and Methodologies for Forecasting, Operational Scheduling and Grid Optimisation", *The evolvDSO Project* (FP7 No. 608732) June 2015. [Online]. Available: <http://www.evolvdso.eu/getattachment/b484e38e-3a9a-4026-9b06-0b5743da2542/Deliverable-3-2.aspx>.
- [43] Mahone, A., et al. "Developing a Greenhouse Gas Tool for Buildings in California: Methodology and User's Manual v. 3, Energy and Environmental Economics, San Francisco CA, December. "The model and documentation are available at: http://www.ethree.com/public_projects/ghg.html (2010).