

Integration of ultrasonic and inertial methods in indoor navigation system

Krzysztof TOKARZ^a, Piotr CZEKALSKI^a, Wojciech SIECZKOWSKI^b

^aInstitute of Informatics
Silesian University of Technology
ul. Akademicka 16, Gliwice, Poland

^bMentor Graphics Polska sp. z o.o.,
Chorzowska 50, 40-121 Katowice, Poland
krzysztof.tokarz@polsl.pl

Abstract: This paper presents integration of ultrasonic and inertial approaches in indoor navigation system. Ultrasonic navigation systems allow to obtain good results whilst there are at least three beacon transmitters in the range of mobile receiver, but in many situations placement of large number of transmitters is not economically justified. In such situations navigation must be aided by other technique. This paper describes research on supporting ultrasonic system by inertial system based on Magnetic, Angular Rate and Gravity sensor. This can measure current orientation of the receiver and allows to estimate the length of the path by pedometer functionality.

Keywords: ultrasonic navigation, inertial navigation, dead reckoning, position measurement.

1. Introduction

Since time immemorial, humans have made efforts to get to know their position. Early navigators measured their position with respect to various celestial bodies and aided themselves with nautical charts, an astrolabe, sextant and chip log [1]. Advances in electronics and telecommunication that took place in the twentieth century, shed a new light on outdoor navigation, introducing technologies such as gyroscopic compass, Long Range Navigation (LORAN), Radio Detection and Ranging (RADAR) and Global Positioning System (GPS) [1]. Whilst outdoor location-aware applications (such as vehicle or people tracking and surveillance, logistical planning, resource discovery, map making and various hobbies, including sports) are widespread today, this work is motivated by the promise of indoor applications that can benefit from being location-aware. As it is unlikely for positioning systems working outdoors to perform well indoors, there is a need to deliver a complementary solution that will satisfy the needs of an application of interest.

The problem of getting to know location information indoors has been studied throughout literature. Different methods, depending on application, have been used

with different results. Interesting approaches uses measurement of strength of radio signals generated by special transmitters or existing wireless network infrastructure. In methods that use ultrasonic signals the delay of ultrasonic pulse is measured. There are also inertial methods with usage of MEMS sensors sometimes supported by electronic compass. This work presents the research on hybrid ultrasound and inertial positioning system.

2. Existing indoor navigation systems

A very good and well documented example of ultrasound based location system is Cricket [2][3], developed at the Massachusetts Institute of Technology. The system is based on the idea of strategic deployment of beacons that transmit ultrasonic and RF messages and roaming devices that measure TDOA between ultrasound and RF. It is important to notice that Cricket allows for the beacon coordinates not to be known at the deployment process but to be figured out later on, when a roaming traveler is placed at known coordinates and basing on traveler to beacon and inter-beacon distances, beacon coordinates are fixed. After such training process, the system is ready to use. Cricket system uses Extended Kalman filtering (EKF, which is a non-linear version of Kalman filter [5]) to get accurate results. Roaming devices were first designed to be entirely passive, but application of Extended Kalman Filter introduced the need for the devices to transmit a message from time to time, when EKF covariance matrix became bad. This is described in details in [3]. Apart from being able to determine the roamer position, a work on getting its orientation is currently under way. A matrix consisting of ultrasonic receivers is used and basing on measured distance differences, the device heading is estimated.

The Active badge system was one of the first indoor location systems. Moving objects to be tracked were attached an infrared badge, periodically transmitting its unique ID. Those transmissions were picked up by fixed infrared receivers and relayed through a wired network to a central computer. From the perspective of modern indoor location systems, due to usage of infrared and wired communication between receivers, Active badge can be treated as a proof of concept that it is possible to design an indoor positioning system and a great motivation for future indoor positioning system developers.

Active bat is a new version of Active badge, which concept is similar to Cricket, as it also uses RF transceivers and ultrasonic transducers. The TDOA between RF and US signals is calculated, as in Cricket. The main difference is that it is the portable device (called the bat) that transmits the ultrasonic pulse, when polled by a central RF base station through radio channel. Ceiling mounted beacons that are in the proximity of the roaming transmitter receive the RF message from central unit followed by the ultrasonic chirp from the roaming device and relay the computed roamer position based on TDOA between RF and US to the central unit. Both Active badge and Active bat were developed at the University of Cambridge [6][7].

The RADAR system developed at Microsoft Research utilizes an already existing 802.11 wireless network [8]. It measures the received RF signals strengths from various

transmitters and tries to obtain position by triangulation as well as compares them with a list of known signatures, stored in a database. This system requires a RF signal map generation before any positioning can be made. This needs additional effort at the deployment phase. Moreover, due to the complex RF waves propagation model, the whole RF signal map needs to be recreated after a change in the environment is made, like moved equipment, new cabinet or a wardrobe is installed etc.

There is also research performed in Silesian University of Technology on using RF signal fusion for indoor navigation described in [4].

One of commercial solutions based on ultrasound is Sonitor. It tracks the location of moveable equipment and people in complex indoor environments. It is designed to provide location information constrained to a single room. It uses wireless detectors and motion-activated 'tags' that are attached to a subject to be monitored. They transmit unique ultrasound identification signal that is received by the detectors and then forwarded to a central computer. Sonitor patented DSP algorithms ensure that the detectors interpret the tag signals without the risk of interference from any environmental noise or other signals nor interfere with sensitive instruments. This is particularly important in a hospital or other complex healthcare setting.

Another interesting system Indoor Atlas uses ambient magnetic field that comes from Earth and other objects like steel beams in buildings. System does not need any special infrastructure and application can be installed on every smartphone equipped with magnetic sensor.

System proposed by Apple named is based on special transmitters named iBeacon placed inside buildings. Apple smartphone can receive signals and calculate its position. iBeacon is Apple's version of Near Field Communication technology.

3. Proposed indoor positioning system

Proposed indoor positioning system is hybrid system that integrates ultrasonic navigation supported by radio transmitters with inertial positioning based on MEMS sensor supported by Magnetic, Angular Rate and Gravity (MARG) sensor. System needs ultrasonic and RF transmitters (beacons) to be located in the building but thanks to inertial part beacons do not have to be located in long corridors. Next sections describes in details ultrasonic part of the system, inertial part and integration of both mentioned parts.

3.1. Ultrasonic positioning

Ultrasonic part of proposed indoor positioning system is based on trilateration with measuring at the traveler Time Difference Of Arrival (TDOA) between received RF messages and US signals. Ceiling mounted beacons periodically transmit RF messages containing beacon specific information (beaconID, coordinates, temperature etc.) followed by an ultrasonic pulse of duration $250\mu\text{s}$. Since RF waves propagate through the air with the speed of light and US wave is much slower [9], it is guaranteed that

provided the RF and US signals were emitted at the same time (or with a small, measurable delay) or one after another, US signal will lag the RF message at the receiver.

The time δT that elapses between RF and US reception is measured and distance d from traveler to the beacon that sent the message can be computed as in (1):

$$\delta T = \frac{d}{v_{US}} - \frac{d}{v_{RF}} + \tau \quad (1)$$

where τ is the cumulative delay, resulting from the delay between US and RF pulse emission at the beacon and interrupt service routine (ISR) processing time at the receiver side. This cumulative delay has been measured on the design process, hard-coded at the receiver and is subtracted at every distance measurement.

3.2. Inertial positioning

Inertial part of IPS works with fusion of magnetometer, accelerometer and gyroscope measurements. The concept of orientation sensing is described in details in [10]. A body's actual movement can be described with six parameters: three translation (in x , y , z direction) and three rotation (α , β , γ) components. Acceleration in 3 directions and angular velocities along 3 axes can be measured using MEMS accelerometers and gyroscopes. As acceleration $a(t)$ is the rate of change of the velocity $v(t)$ of an object in time t , measured values of acceleration can be integrated in order to obtain velocity $v(t)$ (2). The velocity can be then integrated again to obtain displacement $s(t)$ (3).

$$v(t) = \int a(t) dt \quad (2)$$

$$s(t) = \int v(t) dt = \iint a(t) dt^2 \quad (3)$$

As gyroscopes measure rotation velocities rates of change $\omega(t)$, not angular acceleration, a single integration yields angular orientation $\varphi(t)$ (4).

$$\varphi(t) = \int \omega(t) dt \quad (4)$$

Performing the above calculations accurately and periodically, for all three axes x , y , z enables the ideal system to trace its movement with respect to a starting position, which has to be known and to indicate its speed, current position and orientation with respect to the Earth's frame.

It is easy to notice that due to integration operation, both the current system

position and its orientation is estimated basing on previous measurements. A continuous small error in acceleration and angular speed measurements will be included in the integration and the error will grow in time in an unbounded manner. That is why the inertial method of position estimation is supposed to give precise position and orientation estimates for short term measurements, but cannot be considered reliable for long term measurements. It has been investigated that for the accelerometer used, the accumulating error is considerably smaller for fast accelerating or decelerating objects. When the velocity changes slowly in time, the error is much higher. This situation is probably due to MEMS accelerometer characteristic, which is prone to small accelerations or decelerations, when the highest amount of noise is introduced. These conclusions practically rule out application of MEMS accelerometers for displacement estimation by double integration of acceleration, therefore another idea for inertial positioning needs to be implemented. One of IPS assumptions is that the traveler device is handheld. This assumes that the device would be carried by a person. It has been proven [11][12] that when people walk, a vertical movement (with respect to the Earth's frame) of the body can be observed with each step. It is possible to measure acceleration along z-axis in Earth's frame and by means of a peak detection algorithm, detect steps made by the person. It has been proven in [11] that the stride length can vary among people. In order to obtain a correct stride length estimate for each step, the calculated value l_{stride} should be multiplied by a constant factor k . This factor can be either found empirically for each person, or by means of a calibration routine. In order to calibrate the pedometer, the user is asked to travel a known distance. After the user completes the distance, the k factor is adjusted automatically basing on the measured distance, as in (5).

$$k = \frac{\textit{known_dist}}{\textit{measured_dist}} \quad (5)$$

The calibrated value of factor k is stored in EEPROM memory in the traveler device and recalled after each power on.

3.3. Integration of ultrasonic and inertial positioning

Correct deployment of ultrasonic beacons ensures that the ultrasonic signal coverage is available throughout the whole building. However to limit the overall system cost, beacons may be deliberately not installed in places not frequently attended. This would create zones in which no ultrasonic coverage is present. The heading and pedometer information can give an estimated position until beacons are in range again. It may happen that less than three beacons will be in the roaming traveler's range. In that case, a unique, three dimensional position cannot be fixed. When the beacon coverage is lost, last known position from ultrasonic navigation is

treated as the initial position for pedometer-based displacement calculation. The position is estimated by means of dead-reckoning as long as at least one ultrasonic beacon is in range.

When a single beacon is in range of the traveler device, the last position estimated from pedometer and orientation sensor is corrected by the ranging information from the beacon. In order to do that, an optimization problem that minimizes the distance between the last known position p_L and the circle of possible positions p_i is formulated (6).

$$d_{\min} = \min\left(\sqrt{(p_{L,x} - p_{i,x})^2 + (p_{L,y} - p_{i,y})^2}\right) \quad (6)$$

Coordinates of position p_i for which d_{\min} is minimum are set to be the new coordinates of corrected position.

If two beacons are in range, one of two position estimates must be ruled out. The correct solution is chosen by finding the minimum distance between pedometer last dead-reckoned position and those two solutions s_1, s_2 as in (7).

$$p_i = \min\left(\sqrt{(dr_x - s_{1x})^2 + (dr_y - s_{1y})^2}, \sqrt{(dr_x - s_{2x})^2 + (dr_y - s_{2y})^2}\right) \quad (7)$$

4. Implementation

A fully operational system consists of a mesh of deployed ultrasonic beacons allowing to provide the roaming traveler devices with three dimensional location information. Beacons are based on Atmega 644P microcontrollers and are equipped with ultrasonic transducer and RF transceiver working in ISM radio band. Beacons can be powered with 3.3V battery or DC power supply. To ensure system scalability design of each beacon is the same. During deployment, each beacon is given a unique ID and its coordinates are preprogrammed. Fig. 1 shows a simplified block diagram of the beacon.

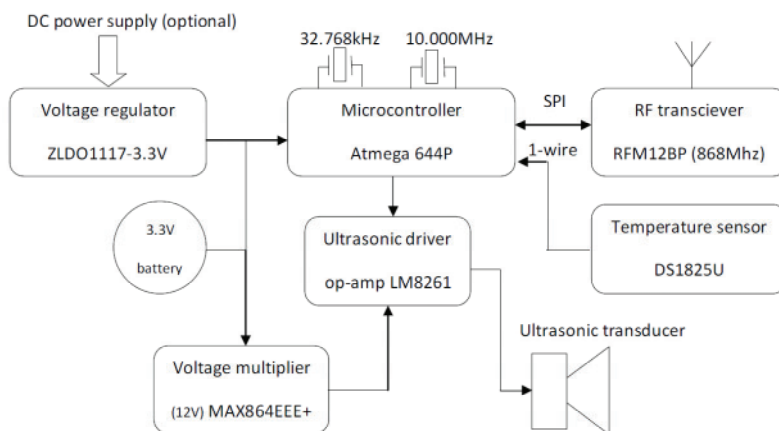

Fig. 1. Block diagram of the beacon device

Traveler device is based on the same model of microcontroller and is equipped with ultrasonic receiver, RF transceiver and LCD display for presentation of navigation data. As it is intended to be mobile it is powered with 3.3V battery. Simplified block diagram of the traveler device is presented in Fig. 2.

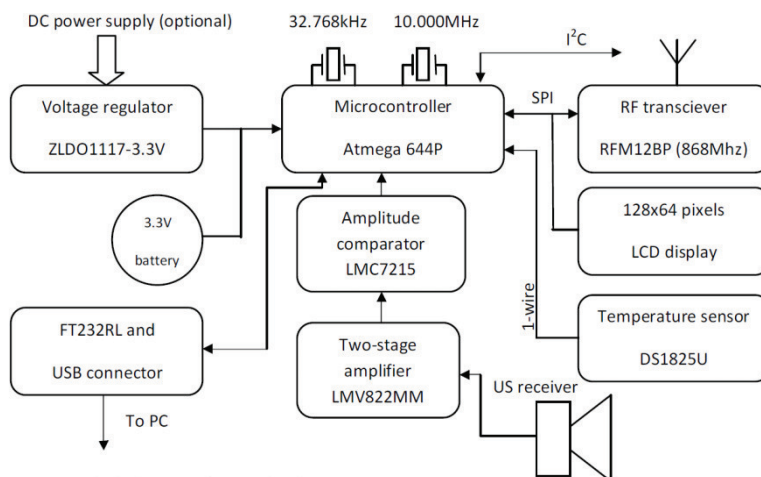

Fig. 2. Block diagram of the traveler device

Additionally, the traveler board is connected to Magnetic Angular Rate Gravitation (MARG) sensor using I2C interface.

5. Test results

A test of integration of ultrasonic and inertial methods of positioning was

performed. A single beacon was used to correct the walk path estimated by orientation sensor and a pedometer. A walk path was constructed as shown in Fig. 3. The path is 2 x 5 m rectangle, dots depict pedometer estimated position, whereas grey line represent ultrasonic estimated position. There was only one beacon used during the test. No ultrasonic coverage was available for the first 4m of the path. As soon as the ultrasonic beacon was in range, position estimated by pedometer was corrected. When the ultrasonic coverage was lost, inertial method of position estimation took over again. A certain amount of deviation from the original angle of walk can be observed. As the test was performed indoors, this deviation is caused by magnetic distortions present from nearby metallic objects.

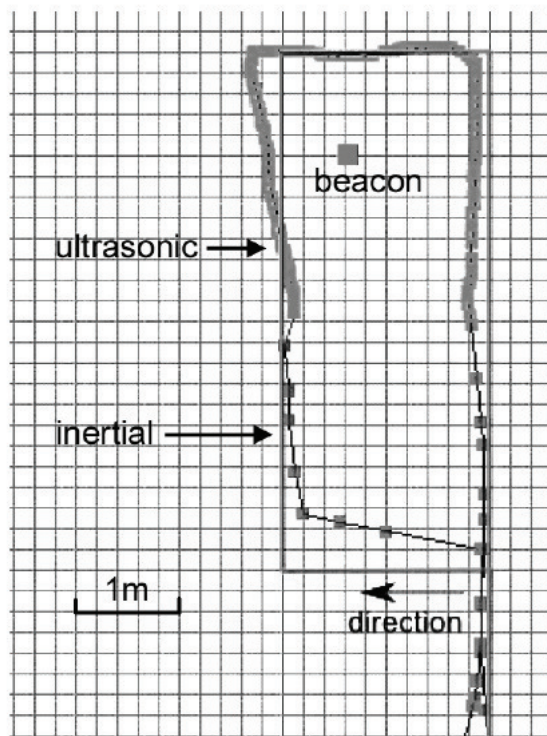

Fig. 3. Walk path for integration of ultrasonic and inertial methods of positioning

6. Conclusions

This work delivers a description of integration of ultrasonic and inertial navigation techniques to implement an Indoor Positioning System. A stand-alone Inertial Positioning System relying on double integration of acceleration measurement has been proven in the literature to be a very inaccurate method of position estimation due to accumulating errors during the integration. Moreover, the assumption was to create

a handheld device that not necessarily will be held parallel to the ground. In that case, to translate the acceleration measurements from sensor frame to Earth's frame – the device rotation in three dimensional space is estimated by application of a MARG sensor. Small errors in orientation estimation result in bigger errors of acceleration measurement with respect to Earth's frame, which combined with errors from double integration, ruled out this approach to dead-reckoning as a method of displacement estimation. An approach was proposed, that is based on detecting steps of a walking person and by analyzing the peak-to-peak value of acceleration during that step, concluding about its length. In combination with orientation information from MARG sensor, this method can be used to estimate a walking person's position provided the initial position is known. As it was stated before, the inertial navigation approach, presented in this work is only to complement the ultrasonic navigation during ultrasonic signal outages and is not coupled with the ultrasonic system in any way. This is a great field for future work to be done. Basing on performance tests, the system is able to give desired level of accuracy, provided the correct deployment is done. Presented way of ultrasonic and inertial positioning integration is only one of many possibilities to do so, therefore a future work in this area is highly encouraged.

References

- [1] Bratcher, A. J. *Navigation at Sea, History of: An entry from Macmillan Reference USA's Water: Science and Issues*. Macmillan Reference USA, 2003.
- [2] Miu, A. K. L. *Design and Implementation of an Indoor Mobile Navigation System*. Master's thesis. Massachusetts Institute of Technology, May 2002.
- [3] Priyantha, N. B. *The Cricket Indoor Location System*. Massachusetts Institute of Technology, June 2005.
- [4] Grzechca D., Biolik B., Chruszczyk Ł., Fiołka J.: *Indoor location based on the signal fusion - mobile device and base station for 433 MHz band*. 3rd International Conference on Indoor Positioning and Indoor Navigation. IPIN 2012, Sydney, Australia, 13-15.11.2012. pp. 40-49.
- [5] Welch G. and G., Bishop G. *An Introduction to the Kalman Filter*. University of North Carolina at Chapel Hill, Dept. of Computer Science.
- [6] Ward, A. M. R. *Sensor-driven Computing*. University of Cambridge, 1998.
- [7] Harter, A., et al. *The Anatomy of Context-Aware Application*. Wireless Networks, February 2002. Vol. 8, pp. 187-197.
- [8] Bahl, P. and Padmanabhan, V. N. *RADAR: An In-Building RF-based User Location and Tracking System*. IEEE INFOCOM 2000, p. 775-784.
- [9] Dean, E.A. *Atmospheric effects on the speed of sound*. Physics Department, University of Texas at El Paso, August 1979.
- [10] Madgwick, S. *An efficient orientation filter for inertial and inertial/magnetic sensor arrays*. April 2010.

- [11] Scarlett, J. *Enhancing the Performance of Pedometers Using a Single Accelerometer*, AN-900 application note. Analog Devices.
- [12] Weinberg, H. *Using the ADXL202 in Pedometer and Personal Navigation Applications*, AN602 Application note. Analog Devices, 2002.

Integracja metody ultradźwiękowej i inercyjnej w systemie nawigacji wewnątrz budynku

Streszczenie

Metody określania aktualnej pozycji są przez ludzkość używane i rozwijane od zawsze. Wczesne metody, stosowane przez wiele lat, zwłaszcza podczas podróży morskich, polegały na określaniu pozycji na podstawie układu widocznych ciał niebieskich, a w późniejszych latach także kompasu. Postęp w elektronice i telekomunikacji, który nastąpił w XX wieku, umożliwił wprowadzenie nowych technologii takich jak kompas żyroskopowy, radary i wreszcie nawigację satelitarną, której przykładem jest system GPS (Global Positioning System). System GPS jest obecnie dostępny dla każdego mieszkańca Ziemi pozwalając na wyznaczenie jego położenia w dowolnym miejscu kuli ziemskiej z dokładnością sięgającą kilku metrów. Dostępne obecnie urządzenia nawigacyjne są z powodzeniem stosowane do lokalizacji w przestrzeni otwartej osób, pojazdów, statków morskich i powietrznych. Niestety, sygnał pochodzący z satelitów jest silnie tłumiony przez konstrukcje budowlane co uniemożliwia zastosowanie satelitarnych odbiorników nawigacyjnych wewnątrz budynków. W literaturze można znaleźć różne metody rozwiązania problemu pozycjonowania obiektu w pomieszczeniach zamkniętych, wykorzystujące różne techniki i zjawiska fizyczne. Wymienić tutaj należy metody bazujące na pomiarze czasu propagacji fal ultradźwiękowych, pomiarze mocy odbieranych sygnałów radiowych generowanych przez specjalne nadajniki lub przez elementy istniejącej infrastruktury sieci bezprzewodowej czy pomiarze przyspieszeń za pomocą czujników MEMS. Kilka systemów doczekało się komercyjnej realizacji (Sonitor, Indoor Atlas, WiGLE, iBeacon). W pracy przedstawiono konstrukcję i wyniki pomiarów hybrydowego systemu pozycjonowania bazującego na pomiarze czasu propagacji fali ultradźwiękowej i radiowej wspomaganego metodą inercyjną. System składa się z rozmieszczonych w obiekcie stacjonarnych urządzeń nadawczych oraz z odbiornika będącego urządzeniem mobilnym. Stacje nadawcze emitują impulsy ultradźwiękowe oraz jednocześnie sygnał radiowy zawierający identyfikator stacji. Mierząc różnicę czasu dotarcia obu sygnałów odbiornik jest w stanie wyznaczyć odległość dzielącą go od nadajnika. Gdy w pomieszczeniu jest kilka nadajników odbiornik, wykorzystując multilaterację, może z dużą dokładnością wyznaczyć swoje aktualne położenie. Urządzenie odbiorcze wyposażone zostało także w czujnik typu MEMS, który pełni funkcję kompasu pozwalając na ustalenie aktualnej orientacji odbiornika względem kierunków geograficznych oraz krokomierza, który służy do oszacowania odległości przebytej przez osobę poruszającą się w przypadku braku sygnału z urządzeń nadawczych. System jest zbudowany z wykorzystaniem mikrokomputerów jednonukładowych z rodziny AVR. Skonstruowany system został poddany badaniom dokładności pozycjonowania, a jego błąd nie przekracza 1m.