

Multiple model adaptive control. Part 2: switching

João Hespanha¹, Daniel Liberzon^{2,*},†, A. Stephen Morse³, Brian D. O. Anderson⁴,
Thomas S. Brinsmead⁴ and Franky De Bruyne⁴

¹*Department of EE-Systems, University of Southern California, Los Angeles, CA 90089, U.S.A.*

²*Coordinated Science Laboratory, University of Illinois at Urbana-Champaign, Urbana, IL 61801, U.S.A.*

³*Department of Electrical Engineering, Yale University, New Haven, CT 06520, U.S.A.*

⁴*RSISE, Australian National University, Canberra ACT 0200, Australia*

SUMMARY

This paper addresses the problem of controlling a continuous-time linear system with large modelling errors. We employ an adaptive control algorithm consisting of a family of linear candidate controllers supervised by a high-level switching logic. Methods for constructing such controller families have been discussed in the recent paper by the authors. The present paper concentrates on the switching task in a multiple model context. We describe and compare two different switching logics, and in each case study the behaviour of the resulting closed-loop hybrid system. Copyright © 2001 John Wiley & Sons, Ltd.

KEY WORDS: linear system; modelling uncertainty; supervisory control; switching logic; hybrid system

1. INTRODUCTION

In this paper we study the problem of controlling a continuous-time SISO linear system in the presence of large-scale modelling uncertainty, noise, and disturbances. The main idea behind the *supervisory control* approach to this problem is to employ logic-based switching among a family of candidate controllers. The need for switching stems from the fact that typically no single controller can guarantee a desired behaviour when connected with the poorly modelled process. Such switching schemes provide an alternative to more traditional continuously tuned adaptive control algorithms. The switching control methodology considered here is ‘estimator-based’, as it relies on an estimation procedure in carrying out on-line controller selection. For background on this subject, see References [1, 2].

In addition to the given process and a family of candidate controllers, the overall supervisory control system contains three other subsystems: a *multi-estimator*, a *monitoring signal generator*, and a *switching logic*. The task of the switching logic is to generate a *switching signal* which determines, at each instant of time, the candidate controller that is to be placed in the feedback loop. Controller selection is based on the values of *monitoring signals*, which are obtained by

* Correspondence to: Daniel Liberzon, Coordinated Science Laboratory, University of Illinois at Urbana-Champaign, Urbana, IL 61801, U.S.A.

† E-mail: liberzon@uiuc.edu

taking integral norms of suitably defined *estimation errors* produced by the multi-estimator. The basic idea behind the switching strategy is to determine which of the monitoring signals is the smallest, and then choose the corresponding candidate controller. This amounts to applying a controller designed for the model that best fits the available data ('certainty equivalence').

This is the second in the series of two papers examining the state-of-the-art of supervisory control methods for uncertain linear systems. The previous paper [3] has addressed various aspects of the problem of choosing the family of candidate controllers. The focus of this paper is on switching between such controllers. The closed-loop systems arising in the supervisory control framework are *hybrid systems*, as they combine discrete dynamics associated with the switching logic and continuous dynamics associated with the rest of the system. In what follows, we describe two different switching logics, and in each case analyze the behavior of the overall hybrid system. One of these switching logics is new, and enables us to overcome technical difficulties in those situations where the parameter space is a continuum.

The supervisory control design procedure outlined above is 'modular', in the sense that the principles governing the design of the switching logic, of the multi-estimator, and of the candidate controllers are essentially independent of each other. The analysis of the overall system relies on basic properties of its different parts, but not on a particular way in which they are implemented. As a result, one gains the advantage of being able to use 'off-the-shelf' control laws, rather than having to design control laws tailored to the specifics of the switching algorithm. Our goal therefore is to make maximal use of relevant concepts from non-adaptive control theory. While the class of systems treated in this paper can also be handled by the control algorithm described in References [1, 2] which uses a different switching logic, the switching control design and analysis tools presented here are potentially applicable in a broader context; in fact, they have already been applied to certain classes of nonlinear systems in References [4–6]. In addition, the proofs are considerably simplified compared to the ones given in earlier work.

2. PROBLEM FORMULATION

Suppose that the uncertain process \mathbb{P} to be controlled admits the model of a SISO finite-dimensional stabilizable and observable linear system with control input u and measured output y , perturbed by a bounded disturbance input d and a bounded output noise signal n . It is assumed known that the transfer function of \mathbb{P} from u to y belongs to a family of admissible process model transfer functions

$$\bigcup_{p \in \mathcal{P}} \mathcal{F}(p)$$

where p is a parameter taking values in some index set \mathcal{P} . Here, for each p , $\mathcal{F}(p)$ denotes a family of transfer functions 'centred' around some known *nominal* process model transfer function v_p (cf. below). Throughout the paper, we will take \mathcal{P} to be a compact subset of a finite-dimensional normed linear vector space.

The problem of interest is to design a feedback controller that achieves output regulation, i.e. drives the output y of \mathbb{P} to zero, whenever the noise and disturbance signals are zero. Moreover, all system signals must remain (uniformly) bounded in response to arbitrary bounded noise and disturbance inputs. Everything that follows can be readily extended to the more general problem of set-point control (i.e. tracking an arbitrary constant reference r) with the help of adding an

integrator in the feedback loop, as in References [1, 2]. Such a modification would not introduce any significant changes as far as the principal developments of this paper are concerned. Control algorithms of the type described here can also be applied to the problem of disturbance suppression [7].

The set \mathcal{P} can be thought of as representing the range of parametric uncertainty, while for each fixed $p \in \mathcal{P}$ the subfamily $\mathcal{F}(p)$ accounts for unmodelled dynamics. There are several ways of specifying allowable unmodelled dynamics around the nominal process model transfer functions v_p . For example, take two arbitrary numbers $\delta > 0$ and $\lambda_u \geq 0$. Then we can define

$$\mathcal{F}(p) := \{v_p(1 + \delta_p^m) + \delta_p^a : \|\delta_p^m\|_{\infty, \lambda_u} \leq \delta, \|\delta_p^a\|_{\infty, \lambda_u} \leq \delta\}, \quad p \in \mathcal{P} \tag{1}$$

where $\|\cdot\|_{\infty, \lambda_u}$ denotes the $e^{\lambda_u t}$ -weighted \mathcal{H}_∞ norm of a transfer function: $\|v\|_{\infty, \lambda_u} = \sup_{\omega \in \mathbb{R}} |v(j\omega - \lambda_u)|$. This yields the class of admissible process models treated in References [1, 2]. Alternatively, one can define $\mathcal{F}(p)$ to be the ball of radius δ around v_p with respect to the Vinnicombe metric [8]. Another possible definition is

$$\mathcal{F}(p) := \left\{ \frac{n_p + \delta_p^n}{m_p + \delta_p^m} : \|\delta_p^n\|_{\infty, \lambda_u} \leq \delta, \|\delta_p^m\|_{\infty, \lambda_u} \leq \delta \right\}, \quad p \in \mathcal{P} \tag{2}$$

where $v_p = n_p/m_p$ is the normalized coprime factorization of v_p (see, e.g., Reference [9]). This is more general than (1) in that it allows for uncertainty about the pole locations of the nominal process model transfer functions. In the sequel, allowable unmodelled dynamics are assumed to be specified in either one of the aforementioned ways; we will refer to the positive parameter δ as the *unmodelled dynamics bound*.

Modelling uncertainty of the kind described above may be associated with unpredictable changes in operating environment, component failure, or various external influences. Typically, no single controller is capable of solving the regulation problem for the entire family of admissible process models. Therefore, one needs to develop a controller whose dynamics can change on the basis of available real-time data. Within the framework of supervisory control discussed here, this task is carried out by a ‘high-level’ controller, called a *supervisor*, whose purpose is to orchestrate the switching among a parameterized family of *candidate controllers*

$$\{\mathbf{C}_q : q \in \mathcal{Q}\} \tag{3}$$

where \mathcal{Q} is an index set. We require this controller family to be sufficiently rich so that every admissible process model can be stabilized by placing in the feedback loop the controller \mathbf{C}_q for some index $q \in \mathcal{Q}$.

In this paper, we will focus exclusively on the case when $\mathcal{Q} = \mathcal{P}$ (although in some situations it may be useful to choose \mathcal{Q} different from \mathcal{P} ; see Reference [10]). For each $p \in \mathcal{P}$, we take for \mathbf{C}_p a controller that stabilizes all the process models in $\mathcal{F}(p)$; such controllers should exist if unmodelled dynamics are sufficiently small. However, \mathcal{P} is typically a continuum, and while it is possible to switch among a continuum of controllers [1, 2], it is often easier to work with a finite controller family. There are various reasons for considering this alternative, having to do with tractability of implementation and analysis. For example, parameters may enter in complicated ways, making estimation over a continuum intractable; the step of actually constructing a continuum of high-performance controllers for a continuum of process models is challenging and certainly constraining, especially if the controllers are to be designed using linear quadratic or \mathcal{H}_∞ techniques. For linear MIMO or nonlinear systems these issues become even more severe.

Therefore, one may want to choose a different parameter space which is finite, and absorb the remaining parameter values into unmodelled dynamics. In carrying out such a program, one is faced with the problem of constructing a *finite* family of controllers having the property that every admissible process model is stabilized by at least one of these controllers. This problem has a solution if unmodelled dynamics are sufficiently small and if the topologies on the parameter space and on the space of transfer functions defining unmodelled dynamics are ‘compatible’, in the sense that v_p is contained in $\mathcal{F}(\bar{p})$ whenever p and \bar{p} are sufficiently close in \mathcal{P} (see Reference [3, Theorem 5.1]). The last assumption is always satisfied when unmodelled dynamics are defined via coprime factorizations or the Vinnicombe metric as outlined earlier, provided that v_p depends continuously on p . The earlier work of Pait [11, 12] is also relevant in this regard.

The reader is thus referred to Reference [3] for issues regarding the construction of controller families like (3), especially finite ones. In the sequel, we will assume that a family of controllers is given, and discuss various ways of carrying out logic-based switching among these controllers to solve the output regulation problem for the unknown process \mathbb{P} .

3. ESTIMATOR-BASED SUPERVISOR

The supervisor consists of three subsystems (see Figure 1):

Multi-estimator \mathbb{E} — a dynamical system whose inputs are the output y and the input u of the process \mathbb{P} and whose outputs are the signals y_p , $p \in \mathcal{P}$. Each y_p would converge to y asymptotically if the transfer function of \mathbb{P} were equal to the nominal process model transfer function v_p and there were no noise or disturbances.

Monitoring signal generator \mathbb{M} — a dynamical system whose inputs are the *estimation errors*

$$e_p := y_p - y, \quad p \in \mathcal{P} \tag{4}$$

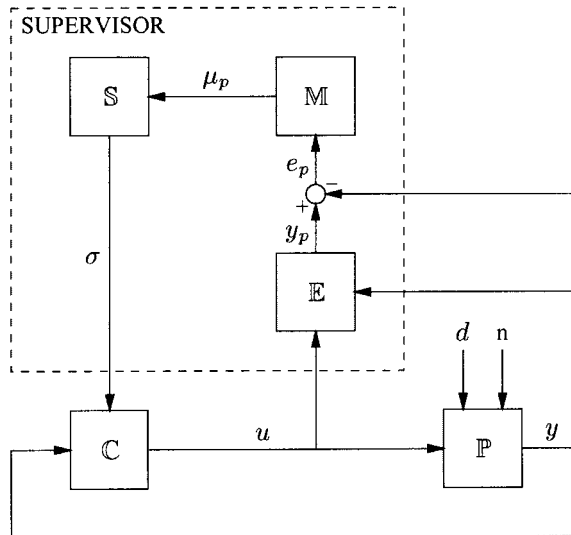

Figure 1. Supervisory control architecture.

and whose outputs $\mu_p, p \in \mathcal{P}$ are suitably defined integral norms of the estimation errors, called *monitoring signals*.

Switching logic \mathbb{S} — a switched system whose inputs are the monitoring signals $\mu_p, p \in \mathcal{P}$ and whose output is a *switching signal* σ , taking values in \mathcal{P} , which is used to define the control law u .

We now briefly recall from Reference [1] the key state-space equations for the different subsystems appearing in Figure 1. As p ranges over \mathcal{P} , let

$$\begin{aligned} \dot{x}_{\mathbb{C}} &= A_p x_{\mathbb{C}} + b_p y \\ u &= k_p x_{\mathbb{C}} + r_p y \end{aligned}$$

be realizations of the transfer functions of the candidate controllers from (3), all sharing the same state $x_{\mathbb{C}}$. We then define the *multi-controller* \mathbb{C} to be the system

$$\begin{aligned} \dot{x}_{\mathbb{C}} &= A_{\sigma} x_{\mathbb{C}} + b_{\sigma} y \\ u &= k_{\sigma} x_{\mathbb{C}} + r_{\sigma} y \end{aligned}$$

Such a multi-controller can be obtained using standard results from realization theory.

We assume that the multi-estimator is also realized in a state-shared fashion, as given by

$$\begin{aligned} \dot{x}_{\mathbb{E}} &= A_{\mathbb{E}} x_{\mathbb{E}} + b_{\mathbb{E}} y + d_{\mathbb{E}} u \\ y_p &= c_p x_{\mathbb{E}}, \quad p \in \mathcal{P} \end{aligned}$$

with $A_{\mathbb{E}}$ a stable matrix. This type of structure is quite common in adaptive control. Note that even if \mathcal{P} is an infinite set, the above dynamical system is finite dimensional. In this case it formally has an infinite number of outputs; however, these outputs will only be needed in the minimization procedure used by the switching logic. Thus, if the associated minimization problem is tractable, then so is the implementation of the overall supervisory control algorithm.

Denoting by x the composite state $(x'_{\mathbb{E}}, x'_{\mathbb{C}})$ of the multi-estimator and the multi-controller, and using (4), we arrive at a system of the form

$$\begin{aligned} \dot{x} &= A_{\sigma} x + d_{\sigma} e_{\sigma} \\ y &= (c_{p^*} \ 0) x - e_{p^*} \\ u &= f_{\sigma} x + g_{\sigma} e_{p^*} \end{aligned} \tag{5}$$

Here $A_p, p \in \mathcal{P}$ are stable matrices all of whose eigenvalues have real parts smaller than $-\lambda_0$ for some $\lambda_0 > 0$, and p^* is an (unknown) element of \mathcal{P} such that the transfer function of \mathbb{P} belongs to $\mathcal{F}(p^*)$, i.e. a ‘true’ parameter value. In addition, the functions $p \mapsto A_p, p \mapsto c_p, p \mapsto d_p, p \mapsto f_p$, and $p \mapsto g_p$ are assumed to be continuous[‡] on \mathcal{P} . See Sections IV and V of Reference [1] for details on this construction.

We will demand that the following condition hold: there exist a positive number λ , positive constants δ_1, δ_2 that only depend on the unmodelled dynamics bound δ and go to zero as δ goes to zero, positive constants B_1, B_2 that only depend on the noise and disturbance bounds and go to zero as these bounds go to zero, and positive constants C_1, C_2 that only depend on the system’s parameters and on initial conditions, such that along all solutions of the closed-loop

[‡] The continuity assumption is made here for simplicity, and can be relaxed in most of what follows. It is of course vacuous if \mathcal{P} is a finite set.

system we have

$$\int_0^t e^{2\lambda\tau} e_{p^*}^2(\tau) \, d\tau \leq B_1 e^{2\lambda t} + C_1 + \delta_1 \int_0^t e^{2\lambda\tau} u^2(\tau) \, d\tau \tag{6}$$

and

$$|e_{p^*}(t)| \leq B_2 + C_2 e^{-\lambda t} + \delta_2 e^{-\lambda t} \sqrt{\int_0^t e^{2\lambda\tau} u^2(\tau) \, d\tau} \tag{7}$$

The above inequalities represent the basic requirements being placed on the multi-controller and the multi-estimator, upon which the subsequent analysis depends. Intuitively, they mean that y_{p^*} is a ‘good’ approximation of y , and provide an explicit characterization of the error $e_{p^*} = y_{p^*} - y$ in the presence of noise, disturbances, and unmodelled dynamics. In the case when unmodelled dynamics are defined via formula (1), it was shown in References [1, 2] how one can construct a supervisory control system satisfying these requirements for each $\lambda \in (0, \min\{\lambda_u, \lambda_0\})$; the desired inequalities were immediate consequences of Equation (28) in Reference [1]. A system with such properties can also be designed in a similar way for the case when unmodelled dynamics are defined via the formula (2) in terms of coprime factors (cf. Reference [13]).

The constant λ from (6) and (7) will play the role of a ‘weighting’ design parameter in the definition of the monitoring signals; we assume, with no loss of generality, that $\lambda < \lambda_0$. Fix an arbitrary constant $\varepsilon_\mu \geq 0$ (its role will become clear in Section 5.2). We generate the monitoring signals $\mu_p, p \in \mathcal{P}$ by the equations

$$\begin{aligned} \dot{W} &= -2\lambda W + \begin{pmatrix} x_E \\ y \end{pmatrix} \begin{pmatrix} x_E \\ y \end{pmatrix}', & W(0) &\geq 0 \\ \mu_p &:= (c_p - 1)W(c_p - 1) + \varepsilon_\mu, & p &\in \mathcal{P} \end{aligned} \tag{8}$$

where $W(t)$ is a symmetric non-negative-definite $k \times k$ matrix, $k := \dim(x_E) + 1$. Since $c_p x_E - y = e_p \, \forall p \in \mathcal{P}$, this yields

$$\mu_p(t) = e^{-2\lambda t} \tilde{\mu}_p(0) + \int_0^t e^{-2\lambda(t-\tau)} e_p^2(\tau) \, d\tau + \varepsilon_\mu, \quad p \in \mathcal{P} \tag{9}$$

where $\tilde{\mu}_p(0) := (c_p - 1)W(0)(c_p - 1)$. The underlying decision-making strategy employed by the supervisor basically consists in selecting for σ , from time to time, the candidate controller index q whose corresponding monitoring signal μ_q is the smallest. The origin of this idea is the concept of certainty equivalence from parameter adaptive control. A precise description of a switching logic that implements this approach is given next.

4. SCALE-INDEPENDENT HYSTERESIS SWITCHING LOGIC

So far we have closely followed the set-up of References [1, 2]. However, the switching logic that we will consider here is different from the one employed there. Namely, we will work with the *scale-independent hysteresis switching logic* [14, 15], whose functioning is as follows (see Figure 2). Assumed given are continuous monitoring signals $\mu_p, p \in \mathcal{P}$ (to define the switching logic, we do not need to require that they be defined by the above formulas, although this is the case to which we will specialize later). Let us pick a number $h > 0$ called the *hysteresis constant*. First, we set

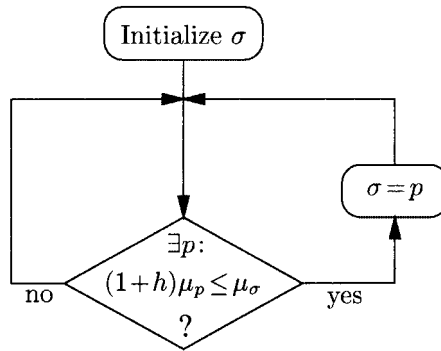

Figure 2. Scale-independent hysteresis switching logic.

$\sigma(0) = \arg \min_{p \in \mathcal{P}} \{\mu_p(0)\}$. Suppose that at a certain time t_i the value of σ has just switched to some $q \in \mathcal{P}$. We then keep σ fixed until a time $t_{i+1} > t_i$ such that $(1 + h)\min_{p \in \mathcal{P}} \{\mu_p(t_{i+1})\} \leq \mu_q(t_{i+1})$, at which point we set $\sigma(t_{i+1}) = \arg \min_{p \in \mathcal{P}} \{\mu_p(t_{i+1})\}$. When the indicated arg min is not unique, a particular value for σ among those that achieve the minimum can be chosen arbitrarily. We refer the reader to Reference [1] for a discussion of tractability issues regarding the minimization procedure (especially when \mathcal{P} is a continuum).

Repeating the above steps, we generate a piecewise constant signal σ which is continuous from the right everywhere. The overall supervisory control system is a hybrid system, σ being its discrete state. If all $\mu_p, p \in \mathcal{P}$ are bounded below by some positive number, then infinitely fast switching (chattering) is avoided. In fact, there must be an interval $[0, T_{\max})$ of maximal length on which σ exists, and there can only be a finite number of switches on each proper subinterval of $[0, T_{\max})$; see References [14, 15] for details. In all the cases treated below, it will be clear that $T_{\max} = \infty$. Hybrid systems having the above property are known as *non-Zeno*.

One can easily see from the definition of the above switching logic that replacing the signals $\mu_p, p \in \mathcal{P}$ by their scaled versions

$$\bar{\mu}_p(t) := \Theta(t)\mu_p(t) \quad p \in \mathcal{P}$$

where Θ is some positive function of time, would have no effect on σ ; this is where the term ‘scale-independent’ comes from. In the sequel, we assume that it is possible to choose Θ in such a way that the scaled signals $\bar{\mu}_p, p \in \mathcal{P}$ are strictly positive and monotone increasing (we will see later that the monitoring signals defined in the previous section satisfy this assumption). For analysis purposes we will always use the signals $\bar{\mu}_p, p \in \mathcal{P}$ that have this property, while the actual monitoring signals being implemented and used for the switching logic are the original ones $\mu_p, p \in \mathcal{P}$.

The analysis of Section 5 is restricted to the case when \mathcal{P} is a finite set. In most situations of interest, the parameter space \mathcal{P} is a continuum. However, it is often possible to work with a different parameter space which is finite, using the results of Reference [3] (see Section 2). The implications of this approach, as well as some alternatives, will be discussed later. One reason for requiring \mathcal{P} to be finite is to be able to use the result from Reference [16] stated next. Given arbitrary numbers $t > t_0 \geq 0$, we will denote by $N_\sigma(t, t_0)$ the number of discontinuities of σ on the

interval (t_0, t) or, more precisely, on the interval $(t_0, \min\{t, T_{\max}\})$ if the finiteness of T_{\max} cannot be ruled out *a priori*.

Lemma 1 (Hespanha et al. [16])

Let $\mathcal{P} = \{1, 2, \dots, m\}$ with m a positive integer. For arbitrary $t > t_0 \geq 0$ we have

$$N_\sigma(t, t_0) \leq 1 + m + \frac{m}{\log(1 + h)} \log\left(\frac{\bar{\mu}_{p^*}(t)}{\min_{p \in \mathcal{P}} \bar{\mu}_p(t_0)}\right) \tag{10}$$

and

$$\sum_{k=0}^{N_\sigma(t, t_0)} (\bar{\mu}_{\sigma(t_k)}(t_{k+1}) - \bar{\mu}_{\sigma(t_k)}(t_k)) \leq m((1 + h)\bar{\mu}_{p^*}(t) - \min_{p \in \mathcal{P}} \bar{\mu}_p(t_0)) \tag{11}$$

where $t_1 < t_2 < \dots < t_{N_\sigma(t, t_0)}$ are the discontinuities of σ and $t_{N_\sigma(t, t_0)+1} := t$

This lemma expresses a general property of the switching logic, which does not depend on the structure of the system or on a particular definition of the monitoring signals. Let us now restrict our attention to the case when the monitoring signals are obtained from Equations (8). Setting $\Theta(t) := e^{2\lambda t}$, we see from formula (9) that the scaled signals $\bar{\mu}_p$, $p \in \mathcal{P}$ are indeed monotone increasing, because they satisfy

$$\bar{\mu}_p(t) = \tilde{\mu}_p(0) + \int_0^t e^{2\lambda\tau} e_p^2(\tau) d\tau + \varepsilon_\mu e^{2\lambda t}, \quad p \in \mathcal{P} \tag{12}$$

Moreover, it is easy to ensure that $\mu_p(0) > 0 \forall p \in \mathcal{P}$, either by setting $\varepsilon_\mu > 0$ or by requiring $W(0)$ to be positive definite. Therefore, we can apply Lemma 1 and conclude that inequalities (10) and (11) are valid. Since in this case the signals $\bar{\mu}_p$, $p \in \mathcal{P}$ are differentiable, the left-hand side of inequality (11) equals the integral $\int_{t_0}^t \dot{\bar{\mu}}_{\sigma(\tau)}(\tau) d\tau$, which is to be interpreted as the sum of integrals over intervals on which σ is constant. From (12) we have the following formula:

$$\dot{\bar{\mu}}_p(t) = e^{2\lambda t} e_p^2(t) + 2\lambda\varepsilon_\mu e^{2\lambda t}, \quad p \in \mathcal{P} \tag{13}$$

5. ANALYSIS: FINITE \mathcal{P}

Take $\mathcal{P} = \{1, 2, \dots, m\}$ as in the previous section. We now proceed to the analysis of the supervisory control system defined by (5), (8), and the switching logic described above. We will sometimes appeal to the state of the uncertain process \mathbb{P} , which we denote by $x_{\mathbb{P}}$.

5.1. No noise, disturbances, or unmodelled dynamics

We begin by considering the simple situation where there are no unmodelled dynamics ($\delta = 0$), i.e. the process \mathbb{P} exactly matches one of the m nominal process models, and where the noise and disturbance signals are zero ($n = d \equiv 0$). In this case, the constants $B_1, B_2, \delta_1, \delta_2$ in (6) and (7) are all zero. Let us take ε_μ in the definition of the monitoring signals to be zero as well ($W(0)$ must then be taken positive definite; see Section 4). Inequality (6) gives $\int_0^t e^{2\lambda\tau} e_p^2(\tau) d\tau \leq C_1$, which together with (12) implies that $\bar{\mu}_{p^*}$ is bounded. It follows from (10) that $N_\sigma(t, t_0)$ is finite for arbitrary $t > t_0 \geq 0$. This means that the switching stops in finite time at some index $q^* \in \mathcal{P}$, i.e. there exists a time T^* such that $\sigma(t) = q^*$ for $t \geq T^*$. Since $\bar{\mu}_{p^*}$ is bounded, we conclude from the definition of the switching logic that $\bar{\mu}_{q^*}$ is also bounded. In view of (12), we have in particular $e_{q^*} \in L^2$. Now it is not hard to see from (5) that, since A_{q^*} is a stable matrix and $e_{p^*} \rightarrow 0$ by virtue of

(7), we have $y \rightarrow 0$. Therefore, the output regulation problem is solved. In light of (5), (8), and detectability of \mathbb{P} , all the other signals remain bounded for all $t \geq 0$ (in fact, here we have $x_p \rightarrow 0$, but this would no longer be true in the case of set-point control where $y \rightarrow r \neq 0$). We summarize this as follows.

Proposition 2

Suppose that the noise and disturbance signals are zero and there are no unmodelled dynamics, and set $\varepsilon_\mu = 0$. Then all the signals in the supervisory control system remain bounded for every set of initial conditions such that $W(0) > 0$. Moreover, the switching stops in finite time, and we have $y(t) \rightarrow 0$ as $t \rightarrow \infty$.

Remark

Since the evolution of x_p and x for $t \geq T^*$ is described by a linear time-invariant system, the rate of convergence in the above statement is actually exponential.

5.2. *Noise and disturbances, no unmodelled dynamics*

We now assume that bounded noise n and disturbance d are present, but there are no unmodelled dynamics. In this case the switching typically will not stop in finite time. In analysing the supervisory control system under persistent switching, the following concept proves useful. Following Reference [17], we say that a switching signal σ has an *average dwell time* $\tau_{AD} > 0$ if there exists a non-negative number N_0 such that the number of discontinuities of σ on an arbitrary interval (t_0, t) satisfies

$$N_\sigma(t, t_0) \leq N_0 + \frac{t - t_0}{\tau_{AD}}$$

It was shown in Reference [17] that if $\{B_p : p \in \mathcal{P}\}$ is a compact set of stable $n \times n$ matrices, then the switched linear system $\dot{z} = B_\sigma z$, $z \in \mathbb{R}^n$ is uniformly exponentially stable for all switching signals σ with a sufficiently large average dwell time. Moreover, by choosing a large enough τ_{AD} , the stability margin of this switched system can be made arbitrarily close to the smallest stability margin of the individual subsystems. This result will be crucial in the analysis given below.

Under the present assumptions, inequalities (6) and (7) hold with some unknown but finite constants B_1, B_2 . The parameters δ_1 and δ_2 are still zero, and C_1 and C_2 are positive constants as before. We take ε_μ to be a positive number. From (6) and (12) we have

$$\bar{\mu}_{p^*}(t) \leq \tilde{\mu}_{p^*}(0) + B_1 e^{2\lambda t} + C_1 + \varepsilon_\mu e^{2\lambda t} \tag{14}$$

Formula (10) then yields

$$N_\sigma(t, t_0) \leq 1 + m + \frac{m}{\log(1 + h)} \log \left(\frac{\tilde{\mu}_{p^*}(0) + B_1 e^{2\lambda t} + C_1 + \varepsilon_\mu e^{2\lambda t}}{\varepsilon_\mu e^{2\lambda t_0}} \right) \leq N_0 + \frac{t - t_0}{\tau_{AD}}$$

where

$$\tau_{AD} = \frac{\log(1 + h)}{2\lambda m} \quad \text{and} \quad N_0 = 1 + m + \frac{m}{\log(1 + h)} \log \left(\frac{\tilde{\mu}_{p^*}(0) + B_1 + C_1 + \varepsilon_\mu}{\varepsilon_\mu} \right)$$

The number τ_{AD} is the average dwell time of σ . It follows from the main result of Reference [17] that if τ_{AD} is large enough, then the switched linear system $\dot{x} = A_\sigma x$ is uniformly exponentially stable, with stability margin λ . This implies that the switched system given by the first equation in

(5) has a finite $e^{\lambda t}$ -weighted \mathcal{L}_2 -to- \mathcal{L}_∞ induced norm, which means that for some positive constants g, g_0 and for all $t \geq 0$ we have

$$e^{2\lambda t}|x(t)|^2 \leq g \int_0^t e^{2\lambda\tau} e_{\sigma(\tau)}^2(\tau) d\tau + g_0|x(0)|^2 \tag{15}$$

We can guarantee that τ_{AD} is large enough by increasing the hysteresis constant h and/or decreasing the weighting constant λ if necessary. The desired lower bound for τ_{AD} can be calculated explicitly from the proof of the main result in Reference [17]. In the sequel, we assume that h and λ have been chosen in such a way that (15) holds.

Using (11), (13), and (14), we obtain

$$\int_0^t e^{2\lambda\tau} e_{\sigma(\tau)}^2(\tau) d\tau \leq m(1+h)(\tilde{\mu}_{p^*}(0) + B_1 e^{2\lambda t} + C_1 + \varepsilon_\mu e^{2\lambda t}) - \varepsilon_\mu e^{2\lambda t_0}$$

Together with (15) this implies that

$$|x(t)|^2 \leq (gm(1+h)(\tilde{\mu}_{p^*}(0) + C_1) + g_0|x(0)|^2)e^{-2\lambda t} + gm(1+h)(B_1 + \varepsilon_\mu)$$

Two conclusions can be drawn from the last formula. First, x is bounded, and as in the previous subsection we can easily deduce from (5), (7), (8), and detectability of \mathbb{P} that all system signals remain bounded. Note that the choice of the design parameters λ, h and ε_μ did not depend on the noise or disturbance bounds, in other words, explicit knowledge of these bounds is not necessary (we are merely requiring that such bounds exist). Second, if n and d equal or converge to zero, then x will approach a neighbourhood of the origin whose size is proportional to $g\varepsilon_\mu$. A close examination of the last quantity (carried out in the appendix for the more general situation of non-zero unmodelled dynamics) reveals that it decreases to 0 as ε_μ goes to 0, which means that we can make this neighbourhood as small as desired by choosing ε_μ sufficiently small. Moreover, e_{p^*} will converge to zero because of (7), hence y will also become arbitrarily small in view of (5). We arrive at the following result.

Proposition 3

Suppose that the noise and disturbance signals are bounded and there are no unmodelled dynamics. Then for an arbitrary $\varepsilon_\mu > 0$ all the signals in the supervisory control system remain bounded for every set of initial conditions. Moreover, for every number $\varepsilon_y > 0$ there is a value of ε_μ leading to the property that if the noise and disturbance signals converge to zero, then for each solution there is a time \bar{T} such that $|y(t)| \leq \varepsilon_y$ for all $t \geq \bar{T}$.

Remark

We cannot simply let $\varepsilon_\mu = 0$, as this would invalidate the above analysis even if $W(0) > 0$. However, by decreasing ε_μ on-line (e.g. in a piecewise constant fashion), it is possible to recover asymptotic convergence of y to zero under the (not very realistic) assumption that the noise and disturbance signals converge to zero.

5.3. Noise, disturbances, and unmodelled dynamics

If unmodelled dynamics are present, i.e. if the parameter δ is positive, then δ_1 and δ_2 in (6) and (7) are also positive. In this case, the analysis becomes more complicated, because we can no longer deduce from (6) that the switched system must possess an average dwell time. However, it is

possible to prove that the above control algorithm, without any modification, is robust with respect to unmodelled dynamics in the following, ‘semi-global’, sense.

Theorem 4

For arbitrary bounds on the noise and disturbance signals, the supervisory control system has the following properties:

1. For every positive value of ε_μ and every number $E > 0$ there exists a number $\bar{\delta} > 0$ such that if the unmodelled dynamics bound δ is smaller than $\bar{\delta}$, then all signals remain bounded for every set of initial conditions such that $|x_p(0)|, |x(0)| \leq E$.
2. For arbitrary positive numbers E and ε_y , there exist a value of ε_μ and a number $\bar{\delta} > 0$ such that if the noise and disturbance signals converge to zero and the unmodelled dynamics bound δ is smaller than $\bar{\delta}$, then for each solution with $|x_p(0)|, |x(0)| \leq E$ there is a time \bar{T} such that $|y(t)| \leq \varepsilon_y$ for all $t \geq \bar{T}$.

Theorem 4 is proved in the appendix in a constructive manner, via a small-gain argument. The difficulty in obtaining a global result can be seen from the proof; it stems from the fact that the gains g and g_0 in (15) depend on the initial conditions (through N_0). This is the price that one pays for allowing the switching to be slow only on the average.

There is an alternative approach which enables one to obtain the same result; it involves modifying the algorithm by introducing *normalized estimation errors*, allowing for a somewhat simpler analysis. Namely, one can define the monitoring signals by using, instead of (8), the equations

$$\begin{aligned} \dot{W} &= -2\lambda W + \begin{pmatrix} x_E \\ y \end{pmatrix} \begin{pmatrix} x_E \\ y \end{pmatrix}', \quad W(0) \geq 0 \\ \dot{\zeta} &= -2\lambda\zeta + u^2, \quad \zeta(0) \geq 0 \\ \mu_p &:= \frac{1}{1 + \zeta} (c_p - 1)W(c_p - 1)' + \varepsilon_\mu, \quad p \in \mathcal{P} \end{aligned}$$

This amounts to replacing the estimation errors e_p , $p \in \mathcal{P}$ by their normalized versions $\bar{e}_p := e_p / (1 + \zeta)$, $p \in \mathcal{P}$. Formula (7) can be used to deduce that \bar{e}_{p^*} is bounded, which immediately leads to the existence of an average dwell time as in the previous subsection. To finish the analysis, one still needs to apply a small-gain argument.

In References [1, 2] a different switching logic was used, which ensures the existence of a dwell time (rather than just an average dwell time) and enables one to prove global stability in the presence of sufficiently small unmodelled dynamics. However, such an approach has its own disadvantages. First, the stability and robustness proofs become more complicated. Perhaps even more importantly, dwell time switching is not suitable for control of nonlinear systems because of the possibility of finite escape times, whereas the scale-independent hysteresis switching logic has already been successfully applied to various classes of nonlinear systems [4–6].

6. LOCAL PRIORITY HYSTERESIS SWITCHING LOGIC

The analysis given in the previous section relied on the assumption that the controller family is finite. As discussed in Reference [3], even if the range of parametric uncertainty is originally

described by a continuum, in many cases of interest one can construct a finite family of stabilizing controllers that possess the desired robustness with respect to unmodelled dynamics. However, we cannot guarantee (at least with currently available analysis tools) that the switching algorithm proposed here preserves the robustness margins associated with the individual controllers. The reason for this can be explained as follows. To establish robustness with respect to unmodelled dynamics, one invariably uses a small-gain argument. However, in inequality (11), which in the present case basically characterizes the e^{At} -weighted induced \mathcal{L}_2 -gain from e_{p^*} to e_σ , the number m of controllers appears on the right-hand side. This implies that if the range of parametric uncertainty is large, which causes m to be large, then the amount of unmodelled dynamics that the switching controller can tolerate becomes small, and might not be sufficient to cover the entire family of admissible process models. It is not hard to see that this problem cannot be overcome by simply increasing the number of controllers being switched.

The above remarks suggest that when the unknown parameters take values in an infinite set, one may sometimes be forced to switch among an infinite family of controllers (as opposed to reducing the problem to that of switching among a finite number of controllers by means of a reparameterization). This is actually the case even in the absence of noise, disturbances, and unmodelled dynamics. If \mathcal{P} is infinite, Lemma 1 is no longer valid, and the analysis given earlier breaks down (in fact, there exist examples in which the switching does not stop even though $\bar{\mu}_{p^*}$ is bounded). In what follows, we propose a new way of dealing with this problem, by means of modifying the switching logic. This enables us to demonstrate how the behaviour of a hysteresis-based supervisory control system can be analysed without relying on \mathcal{P} being a finite set. There are actually several ways to achieve this goal, of which the one presented below is probably the simplest (see Reference [18] for an alternative approach).

We now proceed to the description of the *local priority hysteresis switching logic*. The new switching logic is scale-independent (see Section 4). Its inputs are continuous monitoring signals μ_p , $p \in \mathcal{P}$. One also needs to specify a positive hysteresis constant h and another positive constant γ . A proper choice of γ in the supervisory control context is discussed in the next section. For each $q \in \mathcal{P}$, we define the set

$$D_\gamma(q) := \{p \in \mathcal{P} : |q - p| \leq \gamma\}$$

where $|\cdot|$ stands for the norm in the ambient space of \mathcal{P} .

First, we set $\sigma(0) = \arg \min_{p \in \mathcal{P}} \{\mu_p(0)\}$. Suppose that at a certain time t_i the value of σ has just switched to some $q \in \mathcal{P}$. We then keep σ fixed until a time $t_{i+1} > t_i$ such that the following inequality is satisfied:

$$(1 + h) \min_{p \in \mathcal{P}} \{\mu_p(t_{i+1})\} \leq \min_{p \in D_\gamma(q)} \{\mu_p(t_{i+1})\}$$

at which point we set $\sigma(t_{i+1}) = \arg \min_{p \in \mathcal{P}} \{\mu_p(t_{i+1})\}$. As with the regular scale-independent hysteresis switching, if the argmin is not unique, a particular candidate for the value of σ is chosen arbitrarily. The understanding here is that minimization over $D_\gamma(q)$ is computationally tractable if γ is small.

Repeating the above steps, we generate a piecewise constant signal σ which is continuous from the right everywhere. By the same argument as in References [14, 15], one can show that chattering is avoided if all μ_p , $p \in \mathcal{P}$ are bounded below by some positive number. In fact, there

exists a maximal interval $[0, T_{\max})$ on which σ is defined, and there can only be a finite number of switches on each proper subinterval of $[0, T_{\max})$. As before, in all the cases treated below we will have $T_{\max} = \infty$.

We begin to explore the properties of this new switching logic by proving the following result. We assume again that for some positive function of time Θ the scaled signals $\bar{\mu}_p(t) := \Theta(t)\mu_p(t)$, $p \in \mathcal{P}$ are strictly positive and monotone increasing. We also assume that $\mu_p(t)$ depends continuously on p for every fixed $t \in [0, T_{\max})$.

Lemma 5

Suppose that $\bar{\mu}_{p^*}$ is bounded on $[0, T_{\max})$ for some $p^* \in \mathcal{P}$. Then the switching stops in finite time, i.e. there exists a time $T^* \in [0, T_{\max})$ such that $\sigma(t) = \sigma(T^*)$ for all $t \in [T^*, T_{\max})$. Moreover, $\bar{\mu}_{\bar{q}}$ is bounded on $[0, T_{\max})$ for some $\bar{q} \in D_\gamma(\sigma(T^*))$.

Proof. Let $K = \min_{p \in \mathcal{P}} \{\lim_{t \rightarrow T_{\max}} \bar{\mu}_p(t)\}$. The hypotheses of the lemma imply that K is well defined and finite. Take an arbitrary fixed $\varepsilon \in (0, h)$. We claim that there exists a time $T_\varepsilon < T_{\max}$ such that $\bar{\mu}_p(T_\varepsilon) \geq K/(1 + \varepsilon)$ for all $p \in \mathcal{P}$. Indeed, otherwise there would be a sequence $\{p_n\}$ in \mathcal{P} and a sequence of times $\{t_n\}$ increasing to T_{\max} , with the property that $\bar{\mu}_{p_n}(t_n) < K/(1 + \varepsilon)$. Since \mathcal{P} is compact, $\{p_n\}$ would contain an accumulation point \bar{p} for which we would have $\bar{\mu}_{\bar{p}}(t) \leq K/(1 + \varepsilon)$ for all $t < T_{\max}$, contrary to the definition of K (here we are using the fact that $\bar{\mu}_p, p \in \mathcal{P}$ are monotone increasing).

The sequence of values of σ contains a subsequence $\{q_n\}$ which converges to some $q \in \mathcal{P}$. Pick a time $T^* \geq T_\varepsilon$ such that $|\sigma(T^*) - q| < \gamma$. Then q is an interior point of $D_\gamma(\sigma(T^*))$ relative to \mathcal{P} . Using the definition of the switching logic, it is straightforward to verify that if at least one more switch occurs at some $\bar{t} \geq T^*$, then we must have $\bar{\mu}_p(\bar{t}) \geq K(1 + h)/(1 + \varepsilon) > K$ for all $p \in D_\gamma(\sigma(T^*))$. But this would imply that the values of σ never re-enter $D_\gamma(\sigma(T^*))$ after the time \bar{t} , and we arrive at a contradiction. Therefore, $\sigma(t) = \sigma(T^*)$ for all $t \in [T^*, T_{\max})$.

Let us prove that $\bar{\mu}_{\bar{q}}(t) < K(1 + h)$ for some $\bar{q} \in D_\gamma(\sigma(T^*))$ and for all $t < T_{\max}$. Suppose the contrary: that for every $p \in D_\gamma(\sigma(T^*))$ there is a time $T_p < T_{\max}$ such that $\bar{\mu}_p(T_p) \geq K(1 + h)$. Since $D_\gamma(\sigma(T^*))$ is compact, the same argument as before shows that this would imply the existence of a time $\bar{T} < T_{\max}$ such that $\bar{\mu}_p(\bar{T}) \geq K(1 + h)$ for all $p \in D_\gamma(\sigma(T^*))$. But this would force σ to switch away from, and never re-enter, the set $D_\gamma(\sigma(T^*))$, which contradicts the assertion proved earlier. □

7. ANALYSIS: INFINITE \mathcal{P}

Consider again system (5). Here we assume the index set \mathcal{P} to be infinite (typically a continuum), although all that follows is also valid when \mathcal{P} is finite. Suppose that the monitoring signals are defined via Equations (8), and that the switching signal σ is generated by the local priority hysteresis switching logic described in the previous section. We take the design parameter γ for the switching logic to be small enough so that for every pair of indices $p_1, p_2 \in \mathcal{P}$ satisfying $|p_1 - p_2| \leq \gamma$ the matrix

$$A_{p_1, p_2} := A_{p_1} + d_{p_1}(c_{p_1} - c_{p_2} \ 0) \tag{16}$$

is stable. It is not hard to check that in view of stability of A_p for each $p \in \mathcal{P}$, compactness of \mathcal{P} , and continuity of c_p with respect to p , such a constant $\gamma > 0$ is guaranteed to exist.

We restrict our discussion to the case when the noise and disturbance signals are zero ($n = d \equiv 0$) and there are no unmodelled dynamics ($\delta = 0$). Then Equations (6) and (7) hold with $B_1, B_2, \delta_1, \delta_2$ equal to zero. Let us take ε_μ in the definition of the monitoring signals to be zero as well (the matrix $W(0)$ must then be positive definite; see Section 4). From (6), (12), and continuity of c_p with respect to p , we see that the scaled monitoring signals given by $\bar{\mu}_p(t) = e^{2\lambda t} \mu_p(t)$, $p \in \mathcal{P}$ satisfy the hypotheses of Lemma 5. Therefore, the switching stops in finite time at some index $q^* \in \mathcal{P}$, i.e. there exists a time T^* such that $\sigma(t) = q^*$ for $t \geq T^*$. Moreover, by the same lemma, $\bar{\mu}_{q^*}$ is bounded for some $\bar{q} \in \mathcal{P}$ satisfying $|q^* - \bar{q}| \leq \gamma$. In view of (12), we see that $e_{q^*} \in L^2$.

The first equation in (5) and formula (16) imply that the evolution of x for $t \geq T^*$ is given by

$$\dot{x} = A_{q^*}x + d_{q^*}e_{q^*} = A_{q^*, \bar{q}}x + d_{q^*}e_{\bar{q}}$$

The matrix $A_{q^*, \bar{q}}$ is stable, hence x converges to 0. Furthermore, since $e_{p^*} \rightarrow 0$ by virtue of (7), the output $y = (c_{p^*} \ 0)x - e_{p^*}$ of the process \mathbb{P} also converges to 0. In light of (5), (8), and detectability of \mathbb{P} , all the other system signals remain bounded for all $t \geq 0$ (i.e. $T_{\max} = \infty$). We have thus proved the following counterpart of Proposition 2.

Proposition 6

Suppose that the noise and disturbance signals are zero and there are no unmodelled dynamics, and set $\varepsilon_\mu = 0$. Then all the signals in the supervisory control system remain bounded for every set of initial conditions such that $W(0) > 0$. Moreover, the switching stops in finite time, and we have $y(t) \rightarrow 0$ as $t \rightarrow \infty$.

Remark

As in Proposition 2, since the system describing the evolution of x_p and x for $t \geq T^*$ is linear time invariant, the rate at which y converges to zero must be exponential.

In the recent paper [18], we describe another switching logic for dealing with infinite parameter sets, which allows a successful treatment of noise, disturbances, and unmodelled dynamics.

8. CONCLUDING REMARKS

Our goal has been to discuss recent progress in design and analysis of hysteresis-based supervisory control algorithms for uncertain linear systems. Although the results that we have obtained can also be achieved by using the methods described in References [1, 2], the proofs given here are considerably simpler. Another important advantage of the present approach is that it is more suitable for control of nonlinear systems (as explained at the end of Section 5). In fact, we have already applied these methods to certain classes of nonlinear systems in the absence of noise, disturbances, and unmodelled dynamics (see References [4–6]). In addressing the issue of robustness in the nonlinear case, the work on nonlinear extensions of the Vinnicombe metric [19, 20] and on stable factorizations of nonlinear systems [21, Chapter 5] may prove to be relevant. The Vinnicombe metric may also be useful for designing ‘safe’ multiple model adaptive control algorithms, capable of guaranteeing that one never switches to a controller whose feedback connection with the process is unstable (cf. Reference [22]). This issue is addressed in Reference [23]. The new switching logic described in Section 6 is of interest in its own right, and its properties and implications are to be investigated further.

APPENDIX A: PROOF OF THEOREM 4

From (5) and (6) one obtains

$$\int_0^t e^{2\lambda\tau} e_{p^*}^2(\tau) d\tau \leq B_1 e^{2\lambda t} + D_1 |\bar{x}(0)|^2 + \delta_1 F \int_0^t e^{2\lambda\tau} |x(\tau)|^2 d\tau + \delta_1 G \int_0^t e^{2\lambda\tau} e_{p^*}^2(\tau) d\tau$$

where \bar{x} denotes the composite state (x'_p, x') of the process, the multi-estimator, and the multi-controller, D_1 is a positive constant, $F := 2 \max_{p \in \mathcal{P}} |f_p|^2$, and $G := 2 \max_{p \in \mathcal{P}} |g_p|^2$. Suppose that δ_1 is small enough so that

$$\delta_1 G < 1 \tag{A1}$$

Then we can write

$$\int_0^t e^{2\lambda\tau} e_{p^*}^2(\tau) d\tau \leq \bar{B}_1 e^{2\lambda t} + \bar{D}_1 |\bar{x}(0)|^2 + \delta_1 \bar{F} \int_0^t e^{2\lambda\tau} |x(\tau)|^2 d\tau \tag{A2}$$

where $\bar{B}_1 := B_1/(1 - \delta_1 G)$, $\bar{D}_1 := D_1/(1 - \delta_1 G)$, and $\bar{F} := F/(1 - \delta_1 G)$.

Let $W(0) = 0$ for simplicity. Formula (12) gives

$$\bar{\mu}_{p^*}(t) \leq \varepsilon_\mu e^{2\lambda t} + \bar{B}_1 e^{2\lambda t} + \bar{D}_1 |\bar{x}(0)|^2 + \delta_1 \bar{F} \int_0^t e^{2\lambda\tau} |x(\tau)|^2 d\tau \tag{A3}$$

For an arbitrary pair of positive numbers C, C_0 with $C \geq 1$, we can define the time $T = T(C, C_0) := \sup\{t \geq 0 : |x(t)|^2 \leq C|\bar{x}(0)|^2 + C_0\varepsilon_\mu\} \leq \infty$. For all $t \leq T$ we have

$$\int_0^t e^{2\lambda\tau} |x(\tau)|^2 d\tau \leq \frac{C|\bar{x}(0)|^2 + C_0\varepsilon_\mu}{2\lambda} e^{2\lambda t} \tag{A4}$$

hence

$$\bar{\mu}_{p^*}(t) \leq \varepsilon_\mu \Omega e^{2\lambda t} \tag{A5}$$

where

$$\Omega := 1 + \frac{\bar{B}_1}{\varepsilon_\mu} + \frac{\bar{D}_1 |\bar{x}(0)|^2}{\varepsilon_\mu} + \delta_1 \bar{F} \frac{C|\bar{x}(0)|^2 + C_0\varepsilon_\mu}{2\lambda\varepsilon_\mu}$$

Inequality (10) now implies that for $T \geq t > t_0 \geq 0$ we have

$$N_\sigma(t, t_0) \leq 1 + m + \frac{m}{\log(1+h)} \log \Omega + \frac{2\lambda m}{\log(1+h)} (t - t_0)$$

Thus on the interval $[0, T]$ we have the average dwell time $\tau_{AD} = \log(1+h)/2\lambda m$. We know from the results of Reference [17] that if h is large enough and λ is small enough, then the switched system given by the first equation in (5) has a finite $e^{\lambda t}$ -weighted \mathcal{L}_2 -to- \mathcal{L}_∞ induced norm on this interval, as expressed by inequality (15). Moreover, the gains g and g_0 satisfy the bounds $g \leq D_3 \Omega^{1-r}$ and $g_0 \leq D_4 \Omega^{1-r}$ for some $r \in (0, 1)$ and some positive constants D_3, D_4 that are independent of C and C_0 .

From (11) and (A5) it also follows that

$$\int_0^t e^{2\lambda\tau} e_{\sigma(\tau)}^2(\tau) \, d\tau \leq m(1 + h)\varepsilon_\mu \Omega e^{2\lambda t}$$

Combined with (15), this implies that for all $t \leq T$ we have

$$\begin{aligned} |x(t)|^2 &\leq gm(1 + h)\varepsilon_\mu \Omega + g_0|x(0)|^2 e^{-2\lambda t} \leq m(1 + h)D_3\varepsilon_\mu \Omega^2 + D_4|\bar{x}(0)|^2 \Omega \\ &= D_5D_6^2\varepsilon_\mu + \frac{D_5\delta_1^2\bar{F}^2C_0^2\varepsilon_\mu}{4\lambda^2} + \frac{D_5D_6\delta_1\bar{F}C_0\varepsilon_\mu}{\lambda} + \frac{D_5\bar{D}_1^2 + \bar{D}_1D_4}{\varepsilon_\mu} |\bar{x}(0)|^4 \\ &\quad + \frac{D_5\delta_1^2\bar{F}^2C^2}{4\lambda^2\varepsilon_\mu} |\bar{x}(0)|^4 + (2D_5\bar{D}_1 + D_4)D_6|\bar{x}(0)|^2 + \frac{D_5D_6\delta_1\bar{F}C}{\lambda} |\bar{x}(0)|^2 \\ &\quad + \frac{(2D_5\bar{D}_1 + D_4)\delta_1\bar{F}C}{2\lambda\varepsilon_\mu} |\bar{x}(0)|^4 + \frac{(2D_5\bar{D}_1 + D_4)\delta_1\bar{F}C_0}{2\lambda} |\bar{x}(0)|^2 + \frac{D_5\delta_1^2\bar{F}^2CC_0}{2\lambda^2} |\bar{x}(0)|^2 \end{aligned}$$

where $D_5 := m(1 + h)D_3$ and $D_6 := 1 + \bar{B}_1/\varepsilon_\mu$.

Suppose that $|\bar{x}(0)| \leq E$, where E is given. We can choose C_0 large enough so that the inequality

$$D_5D_6^2 < \frac{C_0}{3}$$

holds, then choose C large enough so that the inequalities

$$\frac{D_5\bar{D}_1^2 + \bar{D}_1D_4}{\varepsilon_\mu} E^2 < \frac{C}{7} \quad \text{and} \quad (2D_5\bar{D}_1 + D_4)D_6 < \frac{C}{7}$$

hold, and finally choose δ_1 small enough so that the inequalities

$$\begin{aligned} \frac{D_5\delta_1^2\bar{F}^2C}{4\lambda^2\varepsilon_\mu} E^2 < \frac{1}{7}, \quad \frac{D_5D_6\delta_1\bar{F}}{\lambda} < \frac{1}{7}, \quad \frac{(2D_5\bar{D}_1 + D_4)\delta_1\bar{F}}{2\lambda\varepsilon_\mu} E^2 < \frac{1}{7}, \\ \frac{(2D_5\bar{D}_1 + D_4)\delta_1\bar{F}C_0}{2\lambda} < \frac{C}{7}, \quad \frac{D_5\delta_1^2\bar{F}^2C_0}{2\lambda^2} < \frac{1}{7} \end{aligned} \tag{A6}$$

hold. Using the above calculations, it is straightforward to check that this implies $|x(t)|^2 < C|\bar{x}(0)|^2 + C_0\varepsilon_\mu$ for all $t \leq T(C, C_0)$, thus for these values of C and C_0 we actually have $T = \infty$. It now follows from (5), (7), (8), (A2), (A4), and detectability of \mathbb{P} that the solutions remain bounded, which proves the first statement of the theorem.

Let us use (11) and (A3) again, combined with the fact that the switched system has a finite $e^{\lambda t}$ -weighted \mathcal{L}_2 -to- \mathcal{L}_2 induced norm:

$$\int_0^t e^{2\lambda\tau} |x(\tau)|^2 \, d\tau \leq \bar{g} \int_0^t e^{2\lambda\tau} e_{\sigma(\tau)}^2(\tau) \, d\tau + \bar{g}_0|x(0)|^2$$

where the gains \bar{g} and \bar{g}_0 are of the same type as g and g_0 above. We obtain

$$\begin{aligned} \int_0^t e^{2\lambda\tau} e_{\sigma(\tau)}^2(\tau) \, d\tau &\leq m(1+h) \left[(\varepsilon_\mu + \bar{B}_1) e^{2\lambda t} + \bar{D}_1 |\bar{x}(0)|^2 + \delta_1 \bar{F} \int_0^t e^{2\lambda\tau} |x(\tau)|^2 \, d\tau \right] \\ &\leq m(1+h) \left[(\varepsilon_\mu + \bar{B}_1) e^{2\lambda t} + (\bar{D}_1 + \delta_1 \bar{F} \bar{g}_0) |\bar{x}(0)|^2 + \delta_1 \bar{F} \bar{g} \int_0^t e^{2\lambda\tau} e_{\sigma(\tau)}^2(\tau) \, d\tau \right] \end{aligned}$$

Choose δ_1 to satisfy inequalities (A1) and (A6), and then decrease it if necessary so as to have $m(1+h)\delta_1\bar{F}\bar{g} < 1$. This implies

$$\int_0^t e^{2\lambda\tau} e_{\sigma(\tau)}^2(\tau) \, d\tau \leq D_7 + D_8(\varepsilon_\mu + \bar{B}_1) e^{2\lambda t}$$

for suitable constants D_7 and D_8 . It follows from (15) that

$$|x(t)|^2 \leq (gD_7 + g_0|x(0)|^2) e^{-2\lambda t} + gD_8(\varepsilon_\mu + \bar{B}_1)$$

If n and d converge to zero, then \bar{B}_1 converges to zero. We also have

$$g\varepsilon_\mu \leq D_3 \left(\varepsilon_\mu + \bar{B}_1 + \bar{D}_1 |\bar{x}(0)|^2 + \delta_1 \bar{F} \frac{C|\bar{x}(0)|^2 + C_0\varepsilon_\mu}{2\lambda} \right)^{1-r} \varepsilon_\mu^r$$

Since $0 < r < 1$, for every given bound E on $|\bar{x}(0)|$ and every $\varepsilon > 0$ the quantity on the right-hand side can be made smaller than ε by choosing ε_μ sufficiently small, selecting C_0, C, δ_1 in accordance with the above inequalities, and decreasing δ_1 further if needed. Moreover, since B_2 in (7) converges to zero, it is not difficult to verify that $|e_{p^*}(t)|$ is bounded by a quantity that converges to

$$\delta_2 \sqrt{\bar{F} \frac{C|\bar{x}(0)|^2 + C_0\varepsilon_\mu}{2\lambda}}$$

as $t \rightarrow \infty$. This can be made arbitrarily small by taking δ_2 sufficiently small. Thus $\lim_{t \rightarrow \infty} |y(t) - (c_{p^*} x - e_{p^*})|$ will not exceed a prescribed $\varepsilon_y > 0$ if the design parameter ε_μ and the unmodelled dynamics bound δ are small enough, which proves the second statement of the theorem. □

REFERENCES

1. Morse AS. Supervisory control of families of linear set-point controllers, Part 1: exact matching. *IEEE Transactions on Automatic Control* 1996; **41**:1413–1431.
2. Morse AS. Supervisory control of families of linear set-point controllers, Part 2: robustness. *IEEE Transactions on Automatic Control* 1997; **42**:1500–1515.
3. Anderson BDO, Brinsmead TS, De Bruyne F, Hespanha JP, Liberzon D, Morse AS. Multiple model adaptive control, Part 1: finite controller coverings. *International Journal of Robust and Nonlinear Control* **10**: 2000:909–929.
4. Hespanha JP, Liberzon D, Morse AS. Logic-based switching control of a nonholonomic system with parametric modeling uncertainty. *Systems Control Letters* 1999; **38**:167–177.
5. Hespanha JP, Liberzon D, Morse AS. Supervision of integral-input-to-state stabilizing controllers. *Automatica* 2000, submitted.
6. Hespanha JP, Morse AS. Certainty equivalence implies detectability. *Systems Control Letters* 1999; **36**:1–13.
7. Fujii S, Hespanha J, Morse AS. Supervisory control of families of noise suppressing controllers. In *Proceedings of the 37th Conference on Decision and Control*, 1998; 1641–1646.
8. Vinnicombe G. Frequency domain uncertainty and the graph topology. *IEEE Transactions on Automatic Control* 1993; **38**:1371–1383.

9. Zhou K, Doyle JC, Glover K. *Robust and Optimal Control*. Prentice-Hall: Englewood Cliffs, NJ, 1996.
10. Morse AS. Logic-based switching and control. In *Feedback Control, Nonlinear Systems, and Complexity* Francis BA, Tannenbaum AR (eds). Springer: New York, 1995; 173–195.
11. Pait FM. On the topologies of spaces of linear dynamical systems commonly employed as models for adaptive and robust control design. Presented at the third SIAM Conference on Control and its Applications, 1995.
12. Pait FM, Kassab Jr F. Parallel algorithms for adaptive control: Robust stability. In *Control Using Logic-Based Switching* Morse AS (ed). Springer: London, 1997.
13. Hespanha JP, Morse AS. Towards the high performance control of uncertain processes via supervision. *Proceedings of the 30th Conference on Information Sciences and Systems*, 1996, 405–410.
14. Hespanha JP. Logic-based switching algorithms in control. *Ph.D. Thesis*, Dept. of Electrical Engineering, Yale University, 1998.
15. Hespanha JP, Morse AS. Scale-independent hysteresis switching. In *Hybrid Systems: Computation and Control*, Vaandrager FW, van Schuppen JH (eds), Lecture Notes in Computer Science, vol. 1569. Springer: Berlin, 1999; 117–122.
16. Hespanha JP, Liberzon D, Morse AS. Bounds on the number of switchings with scale-independent hysteresis: applications to supervisory control. *Proceedings of the 39th Conference on Decision and Control*, 2000, pages 3622–3627.
17. Hespanha JP, Morse AS. Stability of switched systems with average dwell-time. *Proceedings of the 38th Conference on Decision and Control*, 1999; 2655–2660.
18. Liberzon D, Hespanha JP, Morse AS. Hierarchical hysteresis switching. *Proceedings of the 39th Conference on Decision and Control*, 2000, pages 484–489.
19. Anderson BDO, De Bruyne F. On a nonlinear generalization of the v -gap metric. *Proceedings of the 38th Conference on Decision and Control*, 1999; 3851–3856.
20. Vinnicombe G. A v -gap distance for uncertain and nonlinear systems. *Proceedings of the 38th Conference on Decision and Control*, 1999; 2557–2562.
21. van der Schaft A. *L_2 -Gain and Passivity Techniques in Nonlinear Control*. Springer: London, 1996.
22. Anderson BDO, Gevers M. Fundamental problems in adaptive control. In *Perspectives in Control: Theory and Applications*, Normand-Cyrot D, Landau YD (eds). Springer: Berlin, 1998; 9–21.
23. Anderson BDO, Brinsmead TS, Liberzon D, Morse AS. Multiple model adaptive control with safe switching. *International Journal of Adaptive Control and Signal Processing*, 2000, submitted.