

# KIDDY COPTER EVOLUTION

Builders Notes By Charles Helmholdt

## PRELUDE

I first learned about Maker Faire from my youngest son Tony who now works for Tesla. He is a dedicated electric devote who built several electric motorcycles and displayed them at Maker Faire's in the Detroit area. (see photo A)

Tony also helped me with several projects when I built a full size Piper PA-14 Replica airplane which took 13 years to complete and is now on amphibious floats. He acquired his expertise in aviation matters when he attended his high schools aviation extension



Photo A - Tony Helmholdt at Maker Faire in Downtown Grand Rapids showing his first of many electric motorcycle creations.



Photo B -Tony torquing bolts on the prop hub of my PA-14.

program and then later when he attended M-Tec automotive program which is our community colleges trade school for wrench heads. With his experience I had complete confidence in him to assist me with any airplane project. (see photo B)



Photo C - The Kiddy Cubs at Maker Faire, Grand Rapids, MI



After completing my full size airplane project my wife gave me a set of plans for a kiddy sized airplane which I then built with many modifications including nav lights, engine sound, brakes, throttle, etc. I then made another Piper like Kiddy Cub with amphibious floats and then another Kiddy Cub ski-plane with retractable skis operated with electric actuators. With three Kiddy Cub aircraft completed I decided to attend two Mini Maker Faires held in downtown Grand Rapids alongside my son Tony who was displaying his latest two wheel electric motorcycle creations. I gave hundreds of rides to boys and girls ages 3 to 7 at those Maker Faires and had a great time teaching a little about airplanes and aviation. I thought it was a great way to plant an early seed about flying. (see photo C)

The Kiddy Copter came as a result of a dream or epiphany. I came across a small kid pedal cart and I immediately saw there was potential to modifying it into a helicopter. I had never seen anyone make a kid sized helicopter before and thought it would be unique and also be a great asset to my Kiddy Cub collection. But there were big questions that had to be asked and answered before diving in feet first.

## **EXPERIENCE**

I have been a private pilot for the past 40 plus years along with an additional seaplane rating. I am not a helicopter pilot which means I will have a learning curve even if it's only a kiddy helicopter. My goal is to make it look real, sound real, and feel real but not really fly. My one advantage as with the Kiddy Cubs is that I had 13 years of experience building my full size aircraft from plans. Tubing fabrication, welding methods, and other aviation technologies will be second nature if I proceed ahead. (see photo D)



Photo D -The experimental airplane took 13 years to complete.

### 1) Kids Pedal Cart from CHINA

When I came across this cute kids pedal cart it inspired me with the idea of making a kiddy helicopter. It had good proportions for the age group of kids that my Kiddy Cub airplanes have. It also had a very good measured photo side view that I could study and draw on. It costs \$300.00 and would take 6 weeks to deliver so I took the plunge into a new and very unknown project



Kids pedal cart I ordered from China.



2) **Metric Dimensions** gave me a head start while waiting for the cart to arrive. The upside of this purchase is that I did not have to wait for it to arrive and could use the basic dimensions to do some preliminary design layouts.



Useful dimensions gave me an early starting point to make a layout.

### 3) A quick sketch and some important questions.

The Kiddy Cubs were fashioned after the the 1940's model Piper aircraft so I wanted the Kiddy Copter to be in the same classic time frame which suggested the Bell 47 helicopter, the same as seen on the MASH TV series. Its iconic bubble will forever be defined as the classic helicopter design. The big question I had - can I make or buy a bubble for a kids sized helicopter. The sketch gave me a general idea on how big a bubble I needed to research.

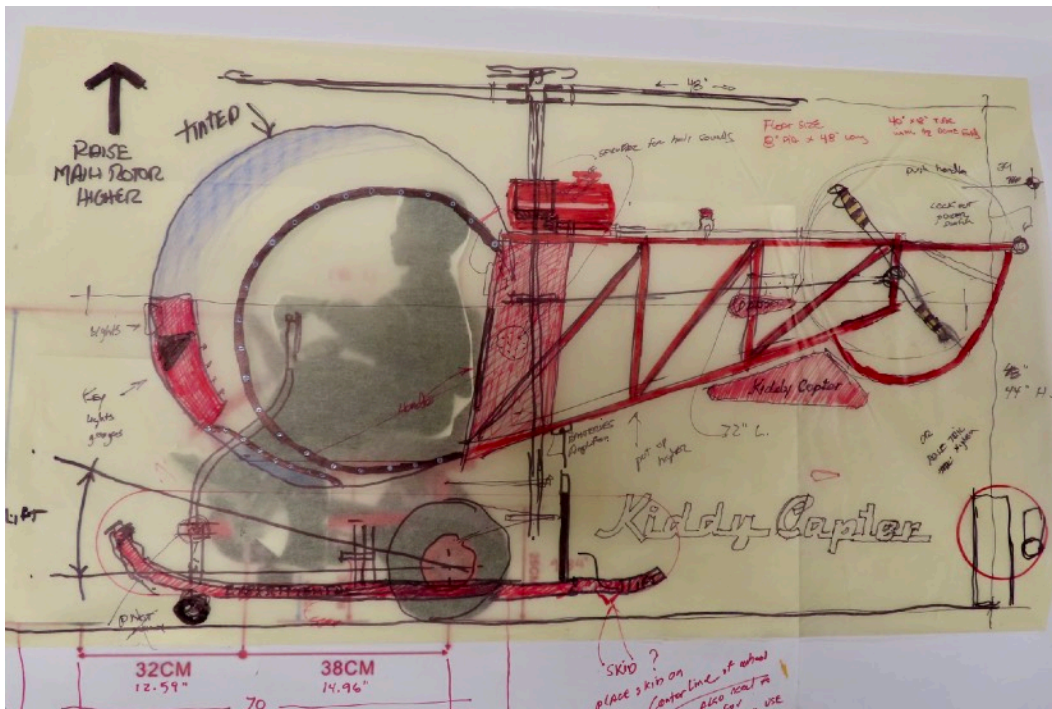

I positioned my transparent sketch paper over the photo of the cart and scaled it so I could reference dimensions using a scaled ruler.



#### 4) The kids cart arrived and now it's time to get serious.

With the cart on my work table I attached some yard sticks that helped me make a more accurate layout drawing that would undergo many changes during the build. This helicopter would evolve not just be built from an original drawing. I had to avoid a narrow design view and instead be adaptable to new directions as needed. One exception to this was the overall size of the vehicle could not exceed 36 inches in width so it could transit doorways of events held at children's museums, hospitals, and other event venues and not exceed 96 inches in length so it could be moved on a trailer and freight elevator. I also wanted it to exceed 48 inches in height for the main rotor to avoid children's standing height for the age groups of 3 to 7 years old.



The yardsticks provided dimensional points to make a more accurate drawing. Tube shapes and diameters were also documented.

##### 5) HORSE BALL IS USED FOR EVALUATING BUBBLE SIZE

I knew from my early sketch that a nominal 30 inch diameter bubble would be needed. I also knew from my experience with my full size experimental airplane that acrylic fabrication of my doors and windshield was expensive and fabrication techniques difficult so I needed something cheaper to look at. I found a 30 inch diameter horse ball on [chewy.com](http://chewy.com) for \$30.00.



I removed the seat and placed the horse ball to simulate the bubble. I also drew circles on the ball to indicate where the openings would be and the suggested diameter. A PVC pipe was set in front of the axles to determine the tube diameter needed for the skids.



## 6) SKID ALIGNMENT WITH AXLE REQUIRED AN AIRLESS TIRE.

For ease of maintenance and problems of inaccessibility I chose an airless heavy duty wheel and tire used on photo carts. These were the same tires and wheels used on the main gear of the Kiddy Cubs. I also chose a 1.75 inch diameter X .049 inch 4130 chrome molly tubing for the skids. I drilled out axle points and installed a lineal bearing for a 15mm stainless steel axle to ride in.



The first piece fabricated was the right side skid and for the moment supported by the carts axle.

## 7) REMOVAL OF STEERING WHEEL AND FRONT WHEELS

The front wheels were replaced with a single caster. The steering wheel and front wheels and tires were completely removed. One inch tubes with curved ends were inserted at the leading edge of the seat to later attach down to the skids. These tubes were dry fitted without welding or fasteners.



Parts of the cart such as the steering wheel and front wheels were removed and new tubing positioned to connect to the cart structure.



## 8) CURVED LEG BRACKETS CONNECT CART TO SKIDS

All remaining tubing is one inch diameter chrome-molly 4130 alloy - the same as the Bell 47. Steel armature pins were located on the skids where the leg frame met. We screwed pins through the tube near their ends to keep the assembly squared up. I would tack weld these joints together after I had the cart frame sandblasted. The curved leg brackets began U shaped and then cut in half. They were on a race car website as parts for a dragster transmission.



The large hoop tube surrounding the seat was one of four I had fabricated to a specific radius.

I found a vendor in Houston to make these very accurate bends.

**9) A NEW MEASURED DRAWING WAS MADE FOR THIS PHASE.**

During this phase of the build I needed to shore up the design to fabricate and order correctly sized parts such as the curved leg brackets, the hoop frames around the seat and back and also the hoop on the tail boom tail skid. This sketch was also useful on determining the bubble size.

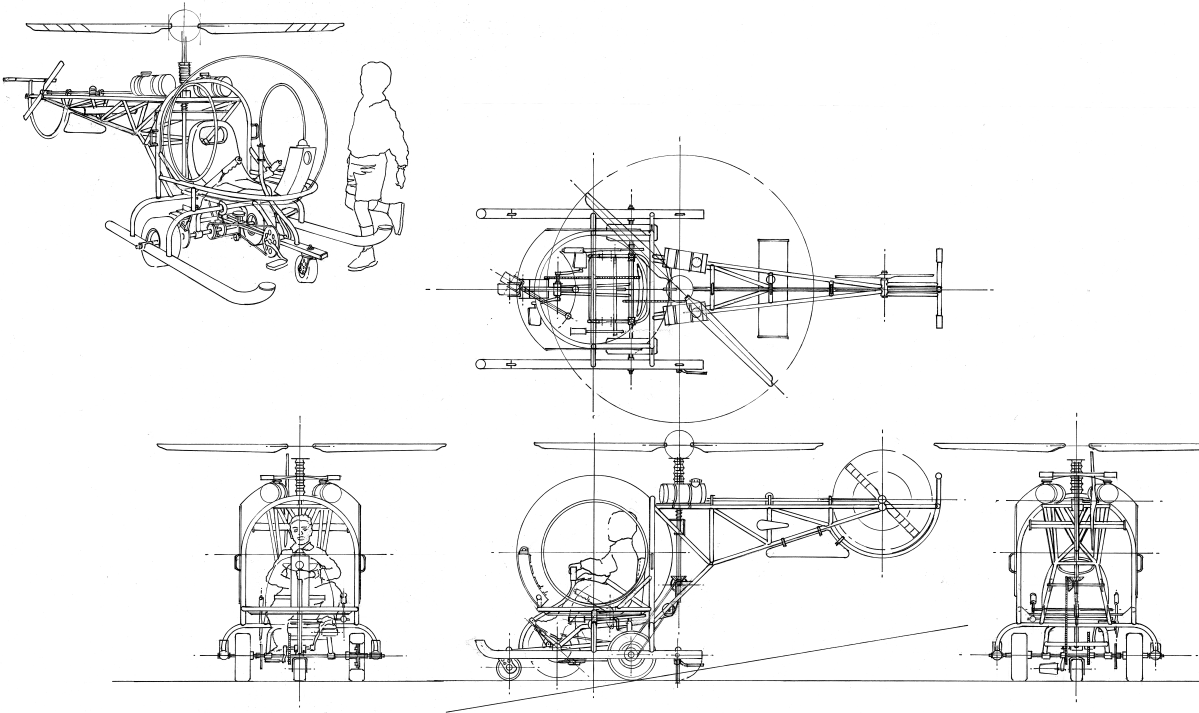

This measured and scaled drawing would serve as a reference for fabricating and ordering special made parts.

**10) CLEARANCE WAS NEEDED FOR KIDS LEGS TO ACCESS PEDALS**

The metal U shaped hoops were designed to cradle the bubble and support the lower part of the bubble and back side of the bubble. It was important to position the hoop that surrounds the seat so as to give adequate access for children's legs and also for pulling up the hand brake lever and the collective lever (not shown).



The Plexiglas bubble will rest in the hoop that surrounds the seat. Clearances for kids legs and lever movements were considered. Also the elevated height of the hoop was needed to determine these clearances.



#### **11) HAND BRAKE SYSTEM WAS ADDED DURING THE BUILD.**

The Kiddy Copter is a self propelled pedal vehicle which needed some means of braking. An easy solution was a Go-Cart Disc Brake connected to a short handle brake lever. At this time in the build I also took the cart frame to the sand blaster.



A Go-Cart disk brake is connected to the cart frame along with a ratcheting short brake lever.

## 12) CONNECTING SKID FRAME TO CART FRAME

With the cart frame sandblasted and the raw 4130 tubes of the skid and leg brackets squared up it was ready for tack welding. Pipe clamps and wood fixtures were used to keep things aligned prior to welding.

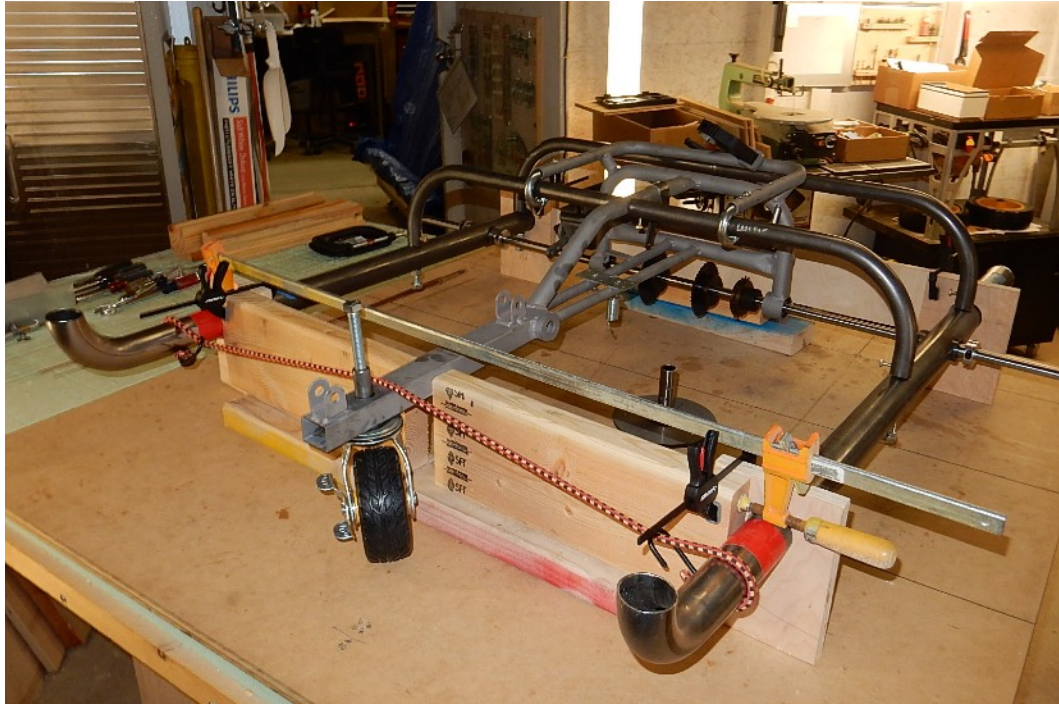

The toe skids were originally U shaped for a handrail return. I inserted a smaller diameter tube inside and then tapped and screwed the components together from the underside.

**13) TACK WELDING THE CART FRAME TO THE SKIDS/LEGS.**

After squaring up the toes I tacked the seams upside down, removed the screws on each side of the joints and then performed two rosette welds from larger holes predrilled on the backside.



I only welded the toe skid joints from below. I did not want an ugly weld line showing between the joints.



#### 14) THE HEIGHT OF THE HOOP ABOVE THE LEGS.

Small vertical tubes were needed to connect the hoop to the gear legs. These were one of many complicated precision parts needed. These were difficult because they needed to be fished-mouthed to agree to the tube direction they were associated with. In this case the lower tube section went one direction and the tube upper section went at a ninety degree angle. (These tubes are not shown - only the gap where the tubes go.)



I used a tube notcher with a one inch hole saw for fish mouthing the joints. It's only as precise as where you put the drill bit pilot in. Many times I had to redo parts improve fitting.

### 15) TWIN ACTUATORS INSTALLED FOR LIFTING KIDDY COPTER.

Two actuators with wheeled ends were installed below the seat. These would be controlled by the operator on the tail post. These 12 Volt 200 pound lifters were intended to simulate a rotor lift-off and rotating around a point. I later would appreciate these devices for loading and unloading the copter from a trailer.



These lifters were designed to lift 200 + pounds 6 inches and simulate a vertical take-off. I can also rotate the helicopter on the lifter wheels and tilt the entire helicopter frame.

## 16) ANOTHER VIEW OF THE HELI FRAME.

This is another view of the frame partially welded together. One huge advantage of using the China go-cart was the pedal chain system with built in bearings and the relationship the pedals had to the seat. Someone in China helped me figure this out instead of me guessing.



This view shows the clean un-welded seam between the front toe skids. All the real welding was done from below. This idea also provided a fool proof method of keeping the toes perpendicular to the skid rails. It was much easier than trying to curve the ends of a long straight tube rail.



## 17) THE SECRET OF THE HOOP FRAMES.

One of the early concerns was how to connect the bubble to the frame. My epiphany was seeing how a bowl planter sat into a metal shaped hoop cradle. The hoop frame acts as a cradle for the bubble as it rests on it and the vertical hoop frame is congruent with the bubble as it rests against it vertically. I made a full size layout drawing using a huge trammel point compass and determined that if the hoops were made with a precise 12 " radius on the center line I would the need the bubble to be formed to an exact 31.25inch diameter. This would allow me to have three identical 20 inch diameter openings.



The proposed bubble would rest in the cradle created by the two hoops. Clearances for kids legs, brake lever, collective lever, and cyclic stick were determined by the riser between the gear legs and the lower hoop.

## 18) PLANNING THE CYCLIC STICK AND HOW IT STEERS.

I could have taken the easy route and just connected the nose wheel to the stick which would have meant that when you swing the stick right the copter goes left - but I wanted to give the kids the real aviation experience which means when you swing the stick to the left you roll left. First I had to make sure I had the room on the cart frame to do double gearing and that I had clearances inside the lower hoop that does not interfere with the kids legs.



The cyclic is only clamped in place at this point while I figure out if I can do a set of double gears to operate the nose wheel steering.

### 19) BUYING THE BUBBLE.

I knew where to buy an acrylic bubble. The vendors 30 inch standard bubble posed problems with my layout. I decided to make a custom size bubble of 31.25 Inch outside diameter with three 20 inch diameter openings. One opening for the legs to go through and the other two opposing openings for the left and right doors. I had to pay extra for custom tooling and because I did not want them to make any mistake I went to my local hobby store and hand drew on a two part acrylic globe the precise diameter of the bubble and orientation of the three openings needed. I mailed this out to them.

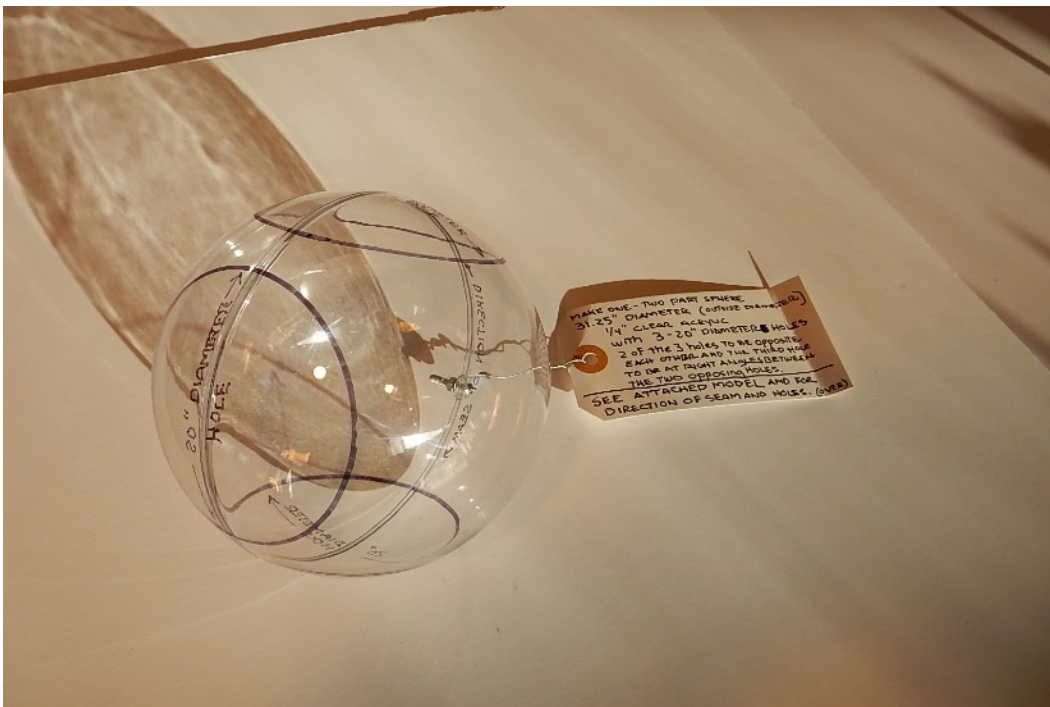

The bubble would be made in two identical parts and fused together. Then the three 20 inch openings would be made per the drawing on the plastic globe.



## **20) CYCLIC (STICK) DOES MORE THAN STEER.**

If you follow the stick downward where it meets up with the cart structure you can see that it is set back from the caster nose wheel. There is a gear below the stick that meshes with a gear welded on the backside of the caster. This allows the stick to go left and makes the caster to steer left and vice versus. I welded a small arm on the lower stick with a gimbaled sleeve that couples with the search light armature. This allows the search light to follow the steering and turns the light in the same direction. The gimbal permits the light to also pitch up & down when the pilot pulls or pushes the stick. The grip on the stick has a larger button that operates the search light along with a feed back light on the stick that confirms that the light is on.



The cyclic or stick controls the steering and turns and pitches the search light up and down as the the stick is pulled or pushed by the pilot.

## 21) THE CYCLIC STEERING MECHANISM IS MADE KID PROOF?

With all the moving parts of the mechanism I had to make sure it was safe and kid proof. It was my experience from the Kiddy Cubs that kids will be kids and will grab, swing, turn, kick, etc. to anything they think is fun to move or remove. After testing and adjusting the mechanism I cross drilled the screwed on connections and pinned them so they could not be turned. I also used nylon stop nuts to make it difficult to unscrew connectors.



A spring was added to give the stick pull back pressure.

## 22) ADDING A BELLOWS TO COVER THE SPRING.

I could imagine a kid in the cockpit moving the stick around while another kid would have his fingers on the steering mechanism and getting his fingers caught in the stretched out spring, Thus the addition of a protective bellows that hides the spring inside and looks cool too!



The cyclic stick is turned to the left and you can also see the caster is turned left and the light is turned left. The gearing is the next thing to keep little fingers from touching.



### 23) THE BUBBLE ARRIVES

The bubble took around six weeks to arrive. It was the largest expenditure and had to be right. It also better not be damaged.



I took pictures of the box the bubble was in before opening it since it looked like it was dropped from a truck.

#### **24) THE BUBBLE CAME BROKEN**

My suspicions were correct. The lower seam became unfused. The company agreed and made a freight claim and begun making a replacement bubble.



The bubble is made in two pieces and then fused together. The seam separation was caused by the shipper.

## 25) BUBBLE IS STILL USEABLE

The damaged bubble could still be used as a place maker and I could confirm it's fit and conformity to the hoop cradles.



The fragility of the unsupported bubble is obvious. Three 20 inch openings and glued seams made me wonder if it would be sturdy enough?



**26) BUBBLE THINNESS IS ALSO A CONCERN.**

The bubble starts out as a 1/4 inch thick acrylic sheet and is heated in an oven then clamped in a press and air pressure expands the sheet into the 1/2 sphere bubble shape. As the sheet expands the 1/4 inch thickness begins to thin out. When I measured it at the edges it was just slightly more than 1/8 inch thick.



The 1/4 inch acrylic thinned out by almost 1/8 inch. This also happens on the full size Bell 47 Helicopter bubble.

## 27) FIRST TEST FIT OF THE BUBBLE.

I added cushioned rubber pipe clamps on intervals around the bottom and back hoops and carefully set the bubble in its hoop cradle and it fit perfectly. I would later replace the pipe clamps with saddle washers and connect the bubble directly to the frame



The cushioned rubber pipe clamps on the hoops prevented scratching the acrylic bubble during the test fit.

## 28) A LOOK INSIDE THE COCKPIT

I was happy to see with the seat installed there was enough clearance for the kids legs to reach the pedals. The collective and brake levers could also move without interference and the cyclic stick could swing from left to right and pitch up and down.



Making full size measured drawings assured a functioning cockpit as parts were installed.



## 29) ADDING GUSSETS AND ADDITIONAL SUPPORT TRIM.

I decided to use the broken bubble even though I had a new replacement on the way. If the fused bubble seams could pop open from shipping damage then I should expect them to fail when the copter is placed in operation. I clamped aluminum support trim across the top seam on both the top and bottom of the bubble to see what it would be like. I would later add gusset plates on each side of the seams on the lower bubble sections to re-enforce the seams.



The side view of the bubble shows the 20 inch diameter openings which were designed to be just inside the hoop cradles. I would later add a PVC trim around each opening to protect the acrylic edge of the bubble.

### 30) PROTECTING THE BUBBLE EDGES FROM KIDS ENTRY.

I became concerned that when kids entered the cockpit they would step on the very fragile edge of the bubble and break it apart. On Amazon I found cool looking handrail brackets and I mated it with a steel disc. I later replaced the disc with a rubber foot pad found on common automotive lift jacks. Later I designed a special weld-on bracket that would cantilever the step over the edge of the bubble.



Protecting the acrylic edge of the bubble from Kids when they enter.

### 31) L SHAPED ALUMINUM BRACKETS ADDED FOR LEVERS.

Aluminum brackets were added to each side to hold the seat rails and parking brake and collective levers.



Lightening holes were machined into the aluminum brackets that hold the seat rails and cockpit levers.



### 32) 12 VOLT MUSIC SYSTEM BENCH TESTED.

I built a 20 watt 12 volt amplifier that would reside in the tray compartment by the tail post. This amplifier would drive the MP3 player and add a little music to the ride. The two yellow speakers would later be located on each side of the copter just below the seats. These speakers were also amplified.

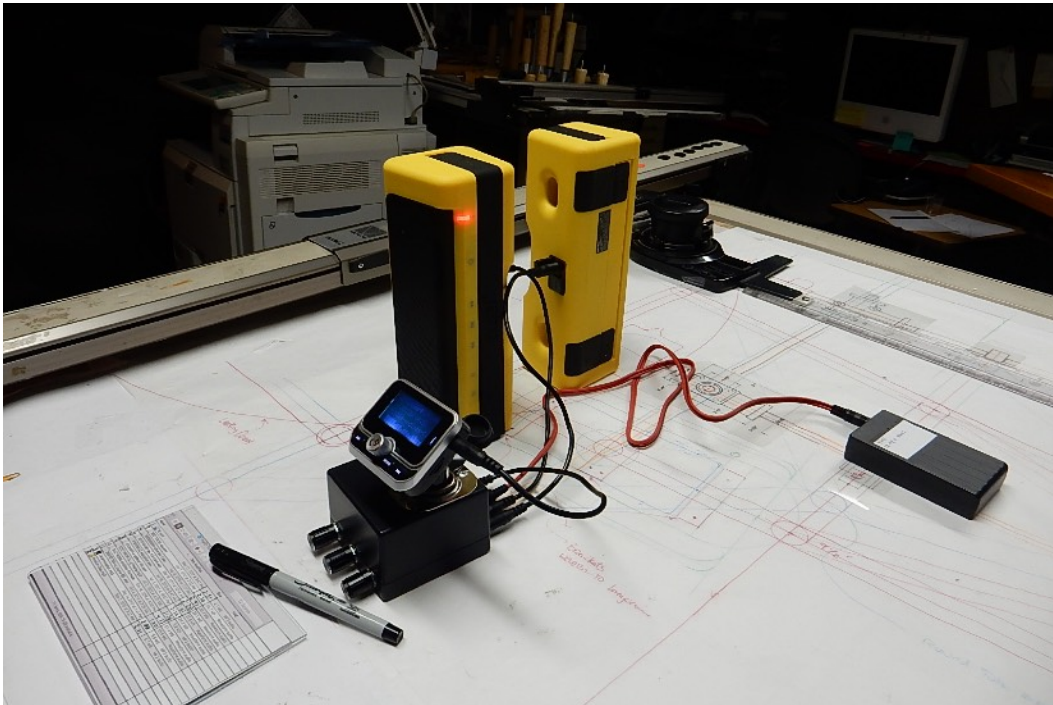

Early testing of the on-board music system assured me it would work when installed in the copter.

### 33) MACHINING THE TERMINATOR TUBES

The first terminator tube in the tail boom is where the tubes V together in a junction or termination point. This short 6 inch long tube had to have 6 precision 1 inch diameter holes drilled. I include this photo to illustrate that all I had was a standard drill press for this project.



Six one inch diameter holes were needed in this short 1 1/2 inch diameter tube to allow the tubes of the tail boom to terminate in.

### 34) LAYING OUT THE TAIL BOOM STRUCTURE.

I made a full size drawing of the tail boom from the side and the top on mylar and stapled it to an MDF board. I started the tube layout upside down and positioned the longerons of the truss over my drawing. These tubes will terminate in the 6 inch terminator.

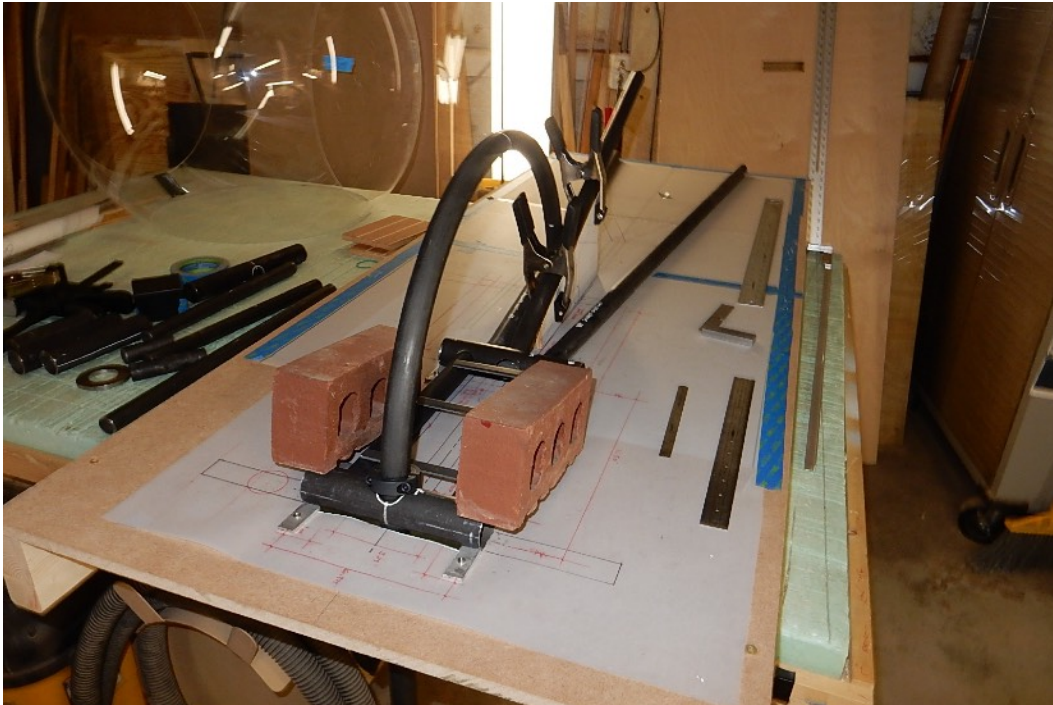

The tail boom starting fabrication upside down over tube drawing layout.  
The hoop is the tail skid and tail post that disappears under the table.



**35) THE TERMINATOR TUBE IS WHERE THE V TUBES MEET.**

The tail boom is shown upside down with the truss tubes are terminating in the terminator tube. The V tube of the truss will act as a conduit for power and signal wires to the control tray by the tail post.

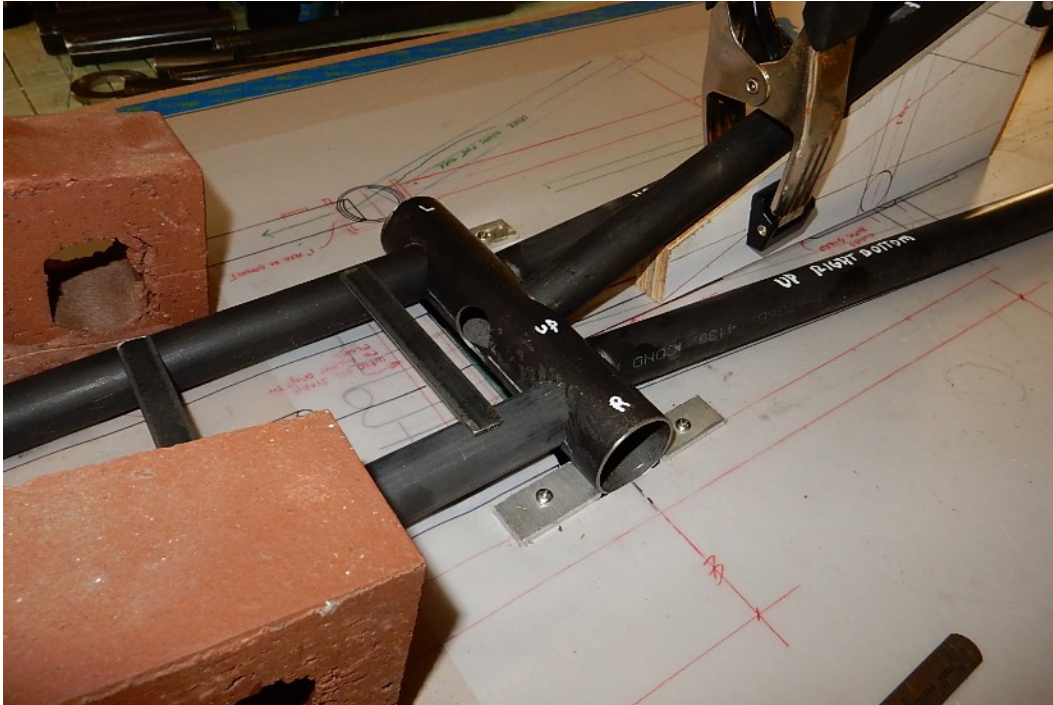

Tubes enter the terminator tube only 1/4 " allowing wiring to enter and connect with operator controls.

### 36) THE TUBE LAYOUT UPSIDE DOWN FIXING THE BOOM ANGLE

Side view of the tail boom with an angled board fixing the angle of the lower V of the truss. The tail skid hoop is positioned to fit on the lower V tube.

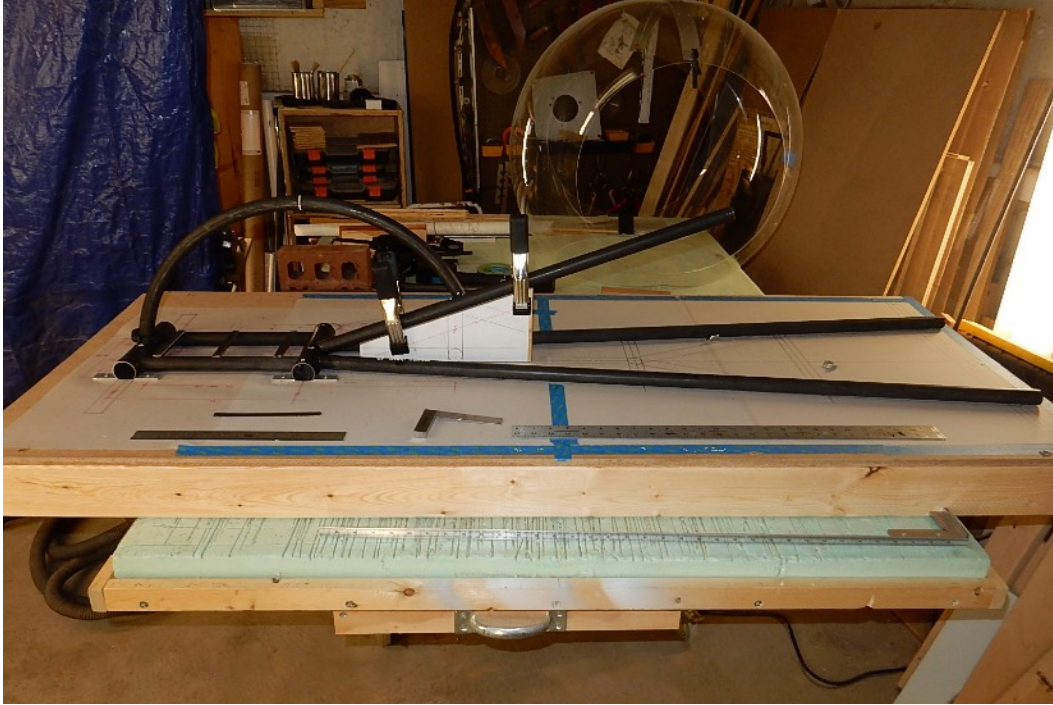

Using the full size mylar drawing keeps tube angles and tube stations in line.

### 37) CLOSE UP OF THE TERMINATOR TUBE UPSIDE DOWN.

The aluminum brackets were used to keep the tubes positioned on the fixture during layout and then during welding.

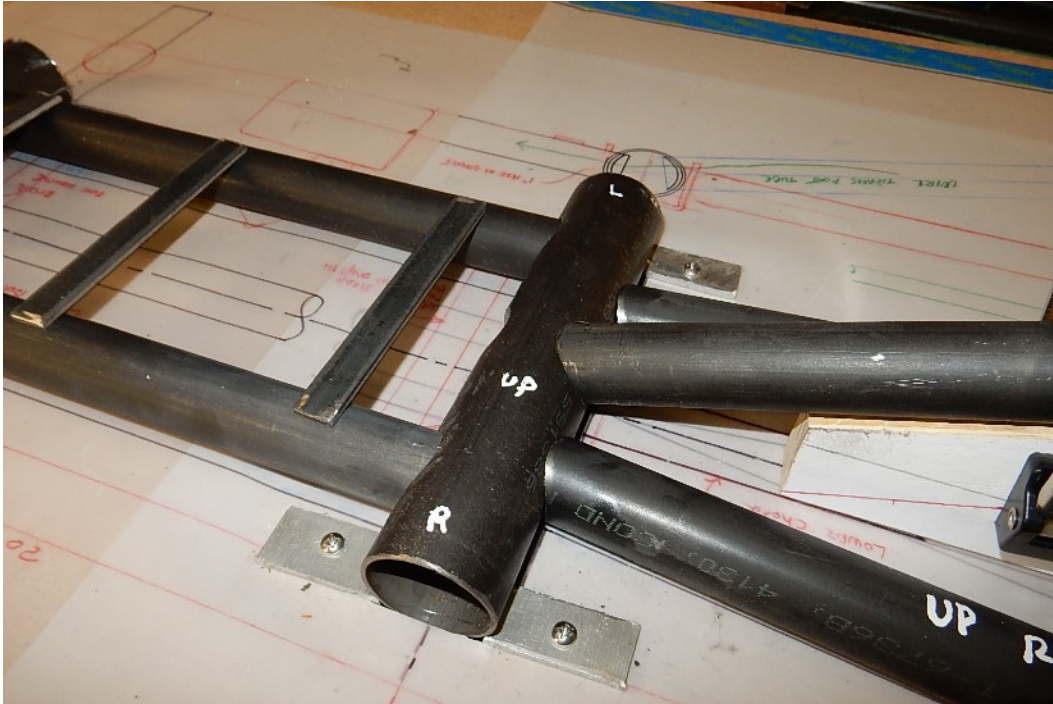

During welding the drawing would be removed but the tubes would remain positioned in the brackets. The cross straps will support a tray for operator control hardware to rest in.



### 38) TAIL BOOM WITH MAIN TUBES WELDED IN PLACE.

With this structure tack welded the next phase was to position the truss upside down again and begin sizing, cutting, and fitting the station tubes and diagonals in the truss frame.



Fish mouthing the tubes in a tapering structure was very labor intensive.  
Many tubes were discarded because of fitting problems.

**39) INTERMEDIATE STATION TUBES WERE TACKED IN FIRST.**  
Stations are V sections spaced 12 inches apart. These stations were welded in first. The diagonals or webs are angled supports of the truss that create the triangulation and strength of the truss.



The triangulation of the truss is what gives it amazing strength.

#### 4o) USING THE TUBES TO MANAGE WIRING

The center V tube that runs the length of the tail boom and terminates in the first terminator tube is a wire way proving a method to get power and signal wires back to the tail post where the adult operator who is pushing the copter can operate the rotor.



Tack welding the tube joints together prevents distortion in the structure.

Tony will finish weld these joints later.



#### 41) ADDING A SADDLE TO THE FIRST TERMINATOR TUBE.

The center V tube that runs the length of the tail boom and terminates in the first terminator tube is a wire way proving a method to get power and signal wires back to the tail post where the adult operator who is pushing the copter can operate the rotor system power, the lift actuators and the music system selection and volume controls. The saddle is the square metal section that fits over the the first terminator tube and will be a mounting saddle for the right angle drive gear box that operates the tail rotor.



The tail boom skid is clamped in the work table. The post on the left is the tail post which will later have a T-handle welded on to push the copter from behind. The two parallel tubes will surround a tray for operator controls and the terminator tube on the right has the square saddle on it for the right angle drive mount.

#### **42) WELDING BRACKETS FOR THE BATTERY BOXES.**

I purchased two plastic lawn mower gas tanks and split them in two halves and installed hinges, vents and power plugs. The boxes would each house two 12 volt lithium batteries. I welded brackets on the truss so I had a method to mount the battery boxes to the tail boom. I got a little ahead of myself and painted them the Kiddy Copter Yellow.



These started out as sealed black plastic Tecumseh fuel tanks for a lawn mower. I split them apart and then had them sandblasted. I then primed and painted the official Kiddy Cub Yellow.

#### 43) PLANNING THE ROTOR SYSTEM.

This photo shows the partially welded truss clamped to a work table. The truss is aligned with the back hoop where they will later be welded together. The platform in the forward section of the truss is where the rotor head will be mounted. The battery boxes will be on each side of the rotor head and a strobe light just in front of the rotor head. Looking further down the truss is the stabilizer wing location.



I never got too far ahead of construction without first taking a break from welding and positioning future components such as the future rotor head location.



#### 44) MOUNTING THE ROTOR HEAD.

The battery boxes would be mounted on top of the tail boom tubes and the rotor head mount would be attached to an aluminum plate on the underside of the truss. The motor is below the aluminum plate. The drive head houses a three way drive gearbox taking power from the motor and up to the rotor blades with a right angle take-off that distributes power down the truss to the tail rotor drive. Height alignment was very important to keep the rotary shaft inline with the bearing blocks on the truss stations.

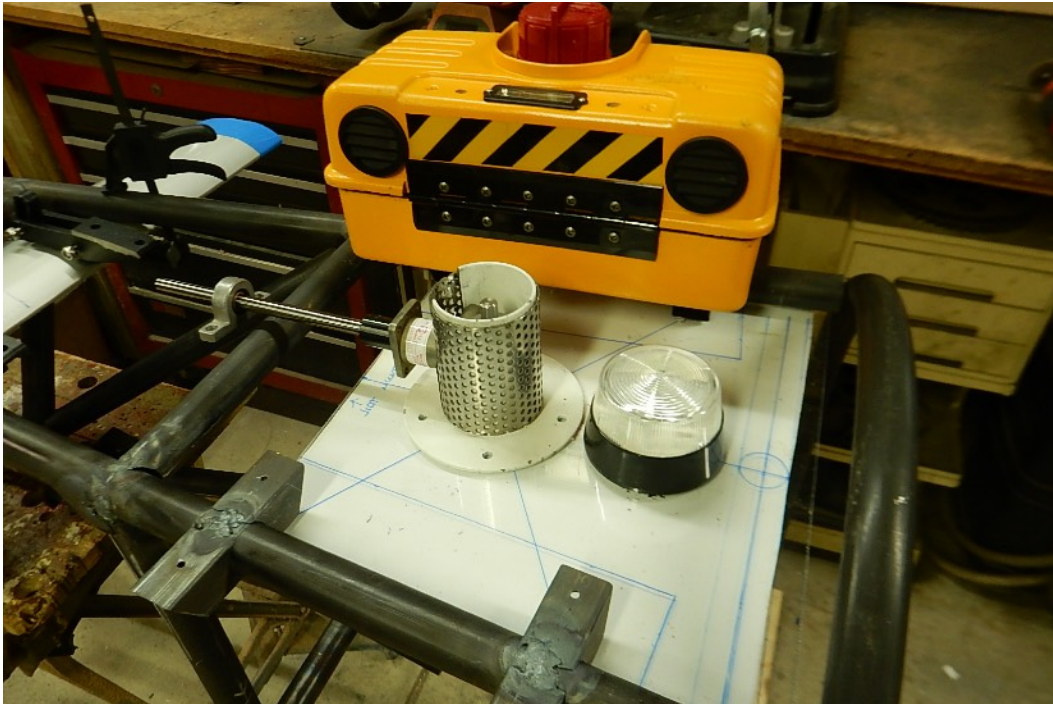

The main rotor system with its many parts would be a challenging chapter in designing the Kiddy Copter.

#### 45) CLEARANCES FOR THE BATTERY BOXES

The hinged battery box may interfere with the rotor system?



I discovered a problem when the lids of the battery boxes interfered with the rotor shaft location. As I made more progress I decided it wasn't much of a problem after all.

#### **46) WELDING IN DIAGONAL SUPPORT TUBES.**

The vertical hoop cradle would be carrying the load of the cantilevered tail boom and the forward load of the bubble. I tack welded in diagonal support braces to strengthen the tube structure.



Tack welding braces to strengthen the tube structure.



#### **47) ADD-ON WING / CAR SIDE SKIRT SPLITTERS**

The underside view of the nose wheel system has a pair of wings that surround the gearing of the nose wheel steering system. These were added to keep little curious fingers away from getting pinched in the gears.



Concealing the gearing action was done for safety purposes to keep little fingers from getting too curious. The wings give it the look of a canard.

#### **48) ADDING THE HORIZONTAL STABILIZER TO THE TRUSS.**

This component was originally a full width spoiler for a car. In order to adapt it to the Kiddy Copter I had to trim it down in half and then tack a rectangular cross brace between the two chord tubes of the truss.



This spoiler's angle could be adjusted but in this case I kept it in a fixed condition. Air dams on the ends would later be added much like a real helicopter.

#### 49) TRIMMING OUT THE OPENINGS OF THE BUBBLE

I planned from the beginning to trim the openings with a PVC type U channel trim. This was important because I did not want the trim to interfere with the hoops and the saddle washer mounting system that I would later use to connect the bubble to the hoop frames.



I installed the trim to see that it would fit but removed it later to make way for other parts.



### 50) VIEW FROM THE BACKSIDE OF THE CAB.

One feature I especially liked is how the bubble meets up with the hoop on the back hoop frame. The plexiglas bubble in this design would prevent any child's hair or other body member from getting entangled with the rotor system.



Children's safety is always the most important consideration and the plexiglas bubble behind the seat will prevent kids hair or hands from getting entangled with the rotor system behind the seat.

## 51) INSTALLING THE VENTRAL FIN.

With the tail boom upside down I determined the shape of the ventral trim on the tail boom.



The ventral fin is a rudder like device to add authority to the tail. It is a fixed non-moveable device added for flight stability. I also have one on my seaplane.

## 52) THE ROTOR SYSTEM AS SEEN FROM BELOW.

The motor mount bracket was on spacers kept below the aluminum mount because I needed a way to adjust the shaft collar. This gap gave me a way to insert a T-handle hex tool to tighten the shaft collar between motor shaft and gear box.



I also determined that a right angle gear drive motor eliminated all wobble on the vertical rotor shaft.



### 53) CLECOS USED TO CLAMP BUBBLE RE-ENFORCEMENTS.

Aluminum strips and gussets were placed on each side of the bubble to strengthen the fused acrylic seams. Clecos are an aviation pre-riveting clamping and hole alignment device. In my example, the aluminum strip is positioned on the bubble then a 1/8 inch hole is drilled through the top strip of aluminum, the acrylic, and the bottom strip of aluminum. Using a Cleco pliers the spring loaded plunger of the cleco is inserted through the hole of the sandwiched assembly. Releasing the cleco plier allows the plunger in the cleco to pull up and tightly clamp the assembly together. When you have all the clecos attached you can remove one at a time and place a rivet in the holes. This technique keeps the holes perfectly aligned.



Clecos were used to clamp the aluminum re-enforcements prior to riveting.

#### 54) FINISH WELDING ON THE TAIL BOOM

Tony is welding on the clusters where several tubes come together. Tack welding the clusters kept them from distorting when the full weld was made.



Bench welding the tail boom allows you to move the work piece any direction in order to get your best view on the weld area.

**55) WHAT IS THE LENGTH OF A ONE INCH DIAMETER WELD?**

To weld around a 1 inch diameter tube equals 3.142". When I counted the joints and clusters I estimate that we welded (Tony Finish Welded) approximately 24 feet of hot welds. At 5000 degrees that's a lot of welding.



Tony is finishing a weld at the terminator tube on the tail post.



## 56) MATING THE CAB TO THE TAIL BOOM.

The upper tubes (chord) of the tail boom were made longer than needed. When lining up the tail boom to the hoop of the cab these tubes were trimmed so they would terminate at a prescribed location on the curve of the hoop. Bosses were attached to the tube hoops that fit inside the chord to keep it aligned for welding.



Back in the day when the full size Bell 47 was manufactured they most likely had precision fixtures to line up welding joints but when you are making a “one of” you don’t have that luxury.

**57) 2 X 4 CRIBBING WAS USED TO SUPPORT THE TAIL.**

Tack welds on the top hoop were first and then tubes were cut and positioned on the lower truss which would self support the truss on the cab.



Levels were referenced but garage floors can be sloping so I used rulers until I knew things were square.

### 58) A VIEW FROM THE TAIL.

This is yet another view from the tail that shows the wood cribbing and how the tail boom meets up with the hoop of the cab.



Any mistake in positioning would show up immediately and make it very difficult to correct. We checked and double checked squareness and made sure it was not dog tracking. Also the tail boom had to be at a perfect right angle to the hoop of the cab.



**59) IT WORKED AND THIS IS PROOF.**

After welding the top chords to the hoop and the lower tube extensions to the cab we now have a self supporting structure and the proof that it is square in "X", "Y", and "Z" axis is shown on the the levels.



A big accomplishment was when we mated the tail to the cab and confirmed that everything was straight and true.

**6o) IT WAS GREAT TO SEE THE HELI TAKING SHAPE.**

Back on the work bench the heli is really starting to look like something. It's exciting to see that we turned a corner and perhaps can proceed in confidence that we have something special here.



There's still more welding to go but the rest is minor and we now know we have a structure that looks like a helicopter.

## 61) PROTECTING THE THIN WALLED TUBING

The one inch diameter 4130 tubing was the .035 thickness. Dropping a tool on it or falling off the work bench would easily damage it so precautions were made to tape some split foam plumbing pipe insulation on certain areas during fabrication.



Split foam plumbing pipe insulation was added first to the tail skid hoop.



## 62) CONNECTING THE BUBBLE TO THE TUBE

Aluminum saddle spacers with nylon washers on both sides of the bubble along with sheet metal screws attach the bubble to the frame from the inside.



The saddle spacers float the bubble in the hoop and keep it from abrading against the metal hoops.

### 63) CHECKING FIT OF WHEELS AND GAS TANK

When drawings are not made of a completed assembly I found it necessary to re-attach components again and again to check and re-check the fit and quite honestly remind me of the construction progress.



Checking wheels, gas tank, and seat for fit.

#### 64) MAN HANDLING THE HELI STRUCTURE.

The only way to get access to the weld areas was to turn it this way and that. The Bell 47s were made on a rotisserie that could be spun around but this little Bell would be moved by muscle.



Luckily for me and Tony is that the welding was done during the summer when it was warm out in Michigan and we could do it outside.



**65) WHEN SOMETHING IS HARD TO CLAMP, USE A SANDBAG.**

This awkward metal beast made it difficult to know where and how to clamp so we found that a strategically placed sandbag would keep it in position during a weld.



When you need to weld around a tube you will need to constantly reposition your workpiece. A sandbag was used to keep it in place.

## 66) TONY DOING A FINISH WELD UPSIDE DOWN.

Gas welding upside down has its dangers. Making the weld puddle upside down could cause a very hot foot for Tony. Luckily there were no serious injuries during the Kiddy Copter Construction.



I can hardly weld upside right but Tony is a natural whatever direction he's in.



**67) EVEN THE BEER CAN'T HIDE.**

When you are doing that much welding you need a beer to cool off.



Close up welding needs a beer to cool off from.



**68) A MID POINT CORRECTION IS NEEDED.**

The 15mm axle that runs through the bearings of the original kid go-cart must stay aligned with the bearings in the skids. For some reason I found that it was binding and not in alignment. The fix made it perfect. I chopped the bearing housing from the kid go-cart and welded on new oversized tubes to the housing. I slipped the oversized tube over the remaining tube structure of the go-cart and bolted them together.



The lighter colored tube in this photo is all that remains of the Kid Go-Cart from China. The bearing housings with bolt throughs is the fix needed to keep the axle running smooth and true through to the skids.

## 69) WEIGHT AND BALANCE CHECK

A cement block (22 pounds) was placed on the seat but the tail still tilted downward. A 25 pound sandbag was placed by the nose wheel which stabilized the situation. I would need to keep a careful eye on this problem since it appears I'm making a tail heavy helicopter.



A cement block on the seat and a sandbag on the nose wheel is trying to balance out a weight and balance issue. On another front I have a couple of posts temporarily supporting the instrument pod next to the bubble. The forward weight of the instrument pod with forward CG will also help with a tail heavy issue.

## 70) LIFT ACTUATORS TESTED AGAIN

With more weight applied to the structure I re-tested the lift actuators. I added more than 100 pounds and saw no problem with actuators.

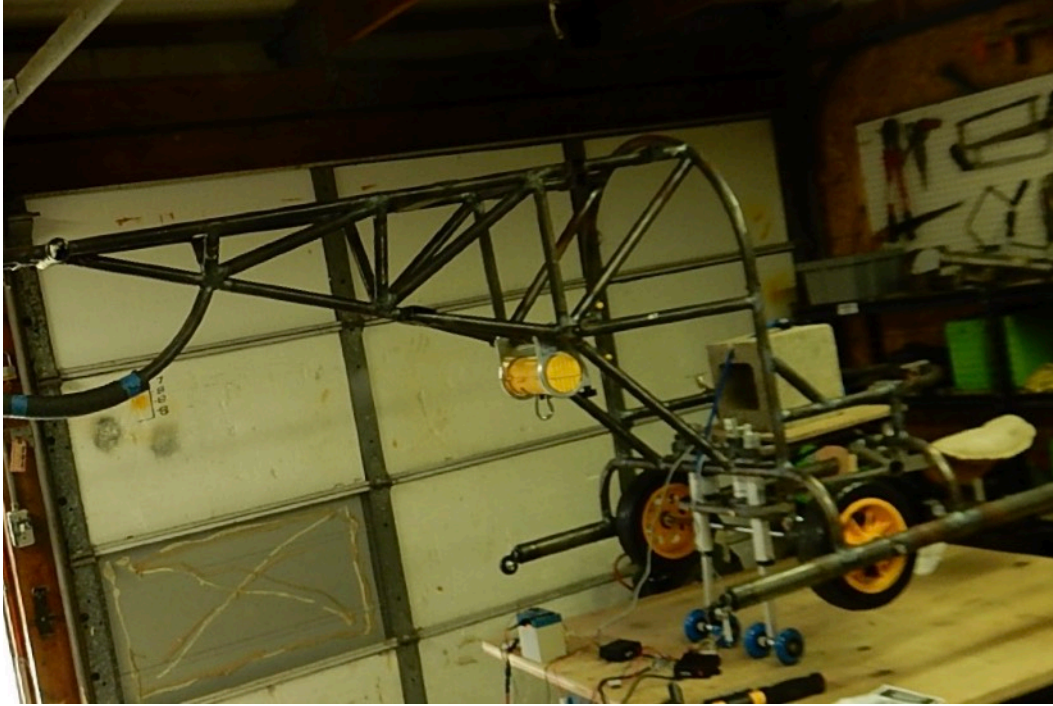

I started with one cement block and eventually added up to 100 pounds and saw no problem with the lifting ability of the actuators.



## 71) WELDING IS DONE. TIME TO PREPARE FOR PAINT.

I learned from my full size airplane how to fabricate, sandblast, prime and paint the fuselage so I would do the same process for the Kiddy Copter. Taking the right steps now will make the airframe last 100 years. The next step after welding is sandblasting. The 4130 tube comes with a very thin mill finish coating that protects the tube from rust while it is being shipped and/or stored. When we welded the joints we would wire brush the coating on the weld joints before welding. I checked with three local sandblasters to help me but I used the word "helicopter" and that set off alarm bells in their heads. Forget it I'll do it myself, but instead of welding I used paint and rust coarse sanding discs to prep the tubes.



The bright metal is where I used the disk.

**72) ALL METAL SURFACES WERE DISKED UNTIL BRIGHT.**

The frame was rotated constantly until every square inch of metal was cleaned off.



One benefit of using the disks versus sandblasting is that it is far less messy, and you don't have to have protective clothing from head to toe.

Only a facemask was needed.



**73) SURFACE CLEANING COMPLETED.**

The frame is cleaned off of all mill finish and ready for primer.

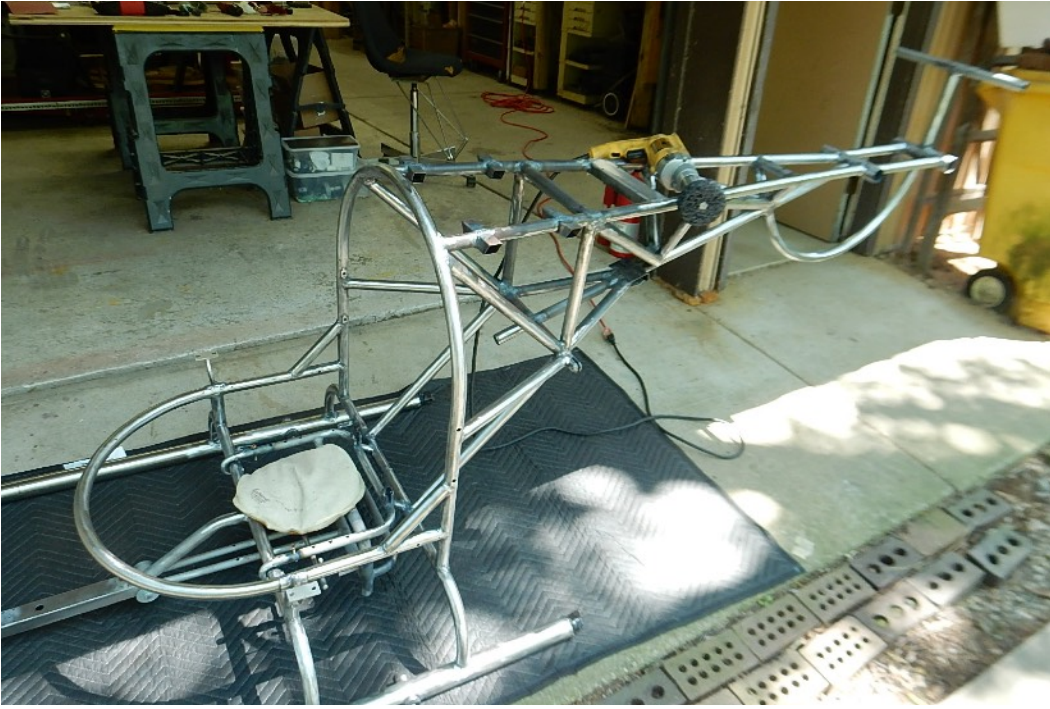

I can give the drill a rest after going through a dozen disks.



#### **74) THE FIRST PRIMER COAT APPLIED.**

Before primer was applied a thorough cleaning of MEK (methyl ethyl ketone) was used. This solvent cleans off all surface oils, disk dust and other surface impurities. We used automotive filler primer in spray cans to deliver the first primer protection coats.



Getting the primer on before any rusting started was most important. A quick drying filler primer allowed us to frequently rotate the frame until all surface area was coated.

### **75) THE FIRST COAT OF SCHOOL BUS YELLOW.**

We chose a spray can color from Ace Hardware that is called “School Bus Yellow Gloss”. It matched the wheel color of the main gear and nose gear perfectly. Using spray cans helped getting in and around the frame much easier than a spray gun with a hose. A standard off-the-shelf spray can color would also lend itself to an easier way to re-touch it later.



Tony is a master painter. He has sprayed his many cars and motorcycles and learned techniques that deliver great results. Even using a spray can he was able to avoid runs and drips and end up with a consistent well coated finish.

## 76) PAINTING REQUIRES PATIENCE

The first pass is to mist on a tack coat. In this step the paint is barely visible. More product can be applied in the second coat.



We did the painting in the cooler evening temperatures and never in the hot sun. Spray cans deliver less product than the typical spray guns and make breathing much easier and safer.



**77) THE THIRD COAT IS THE CHARM.**

It took a dozen spray cans of yellow to get to the desired finish.



One amusing problem when applying the yellow was how it attracted bees. They must have thought it was a big flower.

**78) THE FRESHLY PAINTED FRAME IS READY FOR ASSEMBLY.**

After attaching the wheels and axle I needed to immobilize the copter by placing it in felt covered cradles supporting the skids.



Small felt covered cradles were used to lift the frame and wheels above the work table.

### 79) ADDING PARTS TO THE PAINTED FRAME.

I attached the wheels and axle to check on alignment to make sure nothing got bent in the frame while turning it dozens of times during the cleaning and painting process. The wheels spun freely in their bearings but I would need to take them off again to fit the sprocket and disk brake on.



Wheels and axle were installed first to check that the frame stayed inline during cleaning and painting.



## 80) MORE ASSEMBLY PROGRESS.

The bubble is installed along with the horizontal stabilizer, the lift actuators, beacon, nav lights and nose wheel.

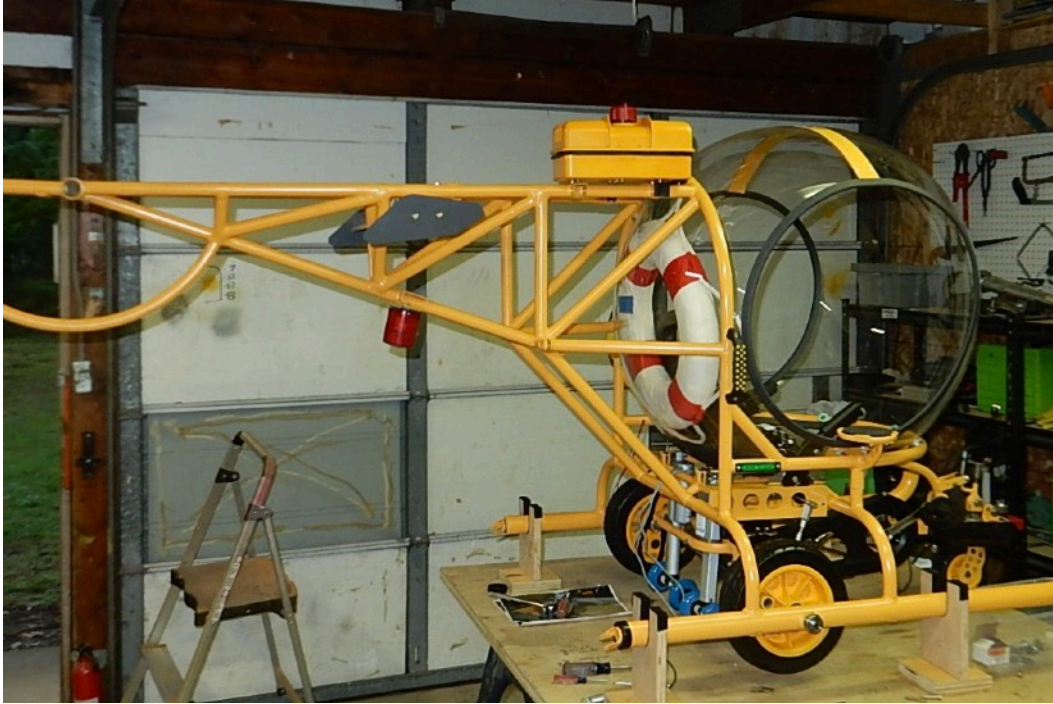

The bubble attachment was time consuming. A 60 degree acrylic drill bit was used to make oversized holes in the plastic so the sheet metal attachment screws with plastic sleeves would never be in direct contact with the acrylic material.

**81) THE INSTRUMENT POD INSTALLATION IS A PRIORITY.**

The instrument pod had to be installed early for all the other wiring to be completed.

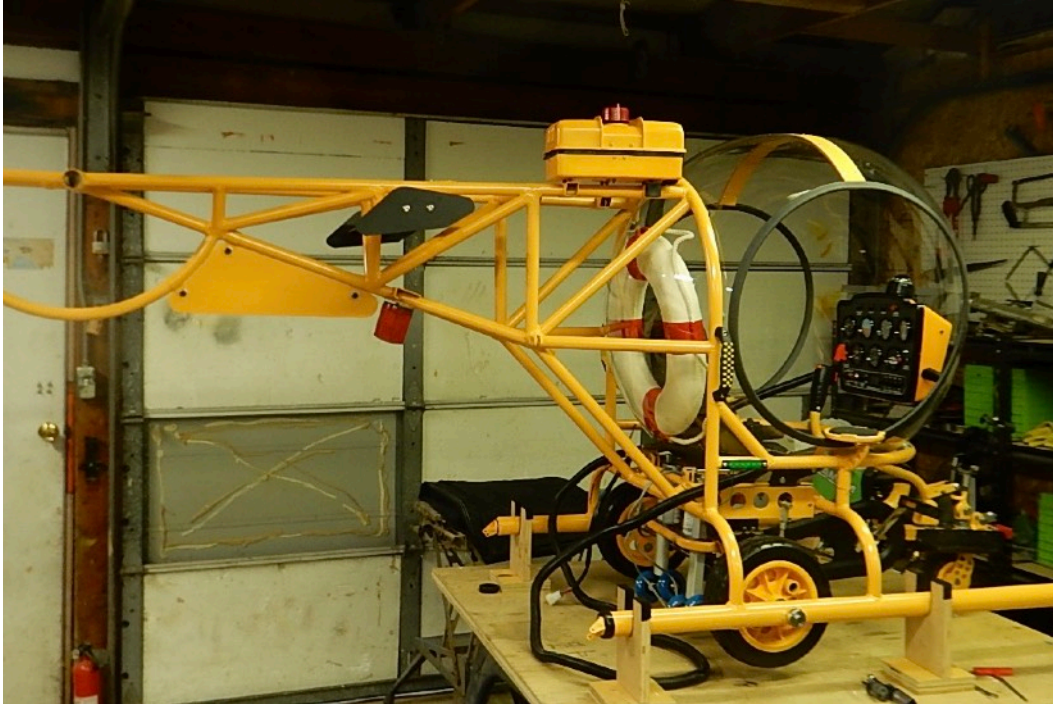

Early installation of the instrument pod was necessary for all the wiring to be completed.

## 82) THE INSTRUMENT POD IS MOUNTED ON THE BUBBLE.

This mounting was tricky. The pod needed to be centered, squared, perpendicular to the ground and elevated at a certain distance from the pilot. A combination of plumb lines, string, carpenter squares, and tape were used to determine the final location. As the pod was held in the final location holes were drilled centered on the rubber spacers. I used these rubber cushioned spacers and nylon washers to affix the pod to the bubble where it floats  $\frac{3}{4}$ " from the inside face.



Mounting the instrument pod to the inside face of the bubble was the only way to mount it.



### 83) GETTING THE WIRING WHERE IT HAS TO GO.

I used two plumbing attachments (one on each side) secured to the instrument pod sides to securely connect one inch diameter split corrugated tubing. These would manage power and signal wires back to the lighting, battery boxes and the operator control tray via the tubing of the tail boom that was also used as wiring conduit.



Managing the wiring was also a safety consideration for the kid pilots. Corrugated tubing was used to conceal and protect the kids from the power and signal wires.

#### 84) GETTING THE WIRING TO THE TAIL OPERATOR CONTROL TRAY.

The bottom chord of the truss or tail boom (tube running back through the “V”) was full length and open all the way through to the first termination point by the tail rotor and thus used as a conduit to the operator control tray for switching power for the rotor motor, actuator power , and music amplification.



The frame tube running through the bottom of the “V”s is an open conduit used for wiring to run up to the operator control tray by the tail post.

**85) LIGHTING SYSTEM TESTED AND ROTOR INSTALLATION STARTED.**

The tail strobe, position lights on the tail post, navigation lights and indicator lights for the switches are lit up. The rotor head and main rotor blades along with the tail rotor are mounted but not functioning.



Both fuel tanks (now the battery boxes) are mounted on the frame. The electrical system runs on 12 volts and is distributed by 4 separately switched 12 volt lithium batteries.



## 86) THE REAR CG (CENTER OF GRAVITY) NEEDED CORRECTION.

The weight of the cantilevered tail boom was causing the helicopter to tilt back even when weight such as a child was in the seat. This condition had to be corrected with ballast. Without adding some thing ugly like lead weight we instead filled the forward sections of the skids with epoxied copper coated lead shot.



A mixture of small copper coated lead shot with an epoxy slurry was first poured into the toe skid through a funnel when the helicopter was tilted backwards. When the mixture was all in the tubes we used the motorcycle lift to tilt the helicopter nose down so the mixture would drain down to the tips and allowed to solidify.

**87) THE EXTRA WEIGHT HELPED BALANCE THE CG OF THE COPTER.**

The copper coated lead weight now sealed inside the tips of the skids brought the CG forward and with a seated kid would keep the copter nose heavy.



We protected the skids with wrappings during the pouring of the epoxy lead shot slurry. The ends of the tubes were capped and sealed later.

### 88) THE MOTOR IS READY FOR MOUNTING.

After testing several motors I selected this right angle gearbox model. It was a 100 rpm "D" Drive 3/8" shaft which would mate up perfectly with the three-way gearbox going up to the rotor. During testing it was a very dependable during quick start ups and shut downs and was very smooth when used with the speed controller. Most importantly it did not induce any wobble into the extended rotor shaft.



The right angle gearbox of this motor provided precision rotation to the rotor shaft above without introducing any motor shaft wobble.



### **89) THE MOTOR MOUNT AREA AS SEEN FROM BELOW .**

We would use only one 12 volt motor for turning both the main rotor and tail rotor. The real Bell 47 used one motor also but had a transmission that would turn the tail rotor 4 to 5 times faster than the main rotor. This was needed to counteract the torque forces of the main rotor. These tail rotor forces were controlled by adjusting the blades on the tail rotor with the rudder pedals. Our little Kiddy Copter does not have rudder pedals or adjustable blades on the tail rotor so it will be a simplification by just spinning around at the same rpm as the main rotor.



The location of the one and only motor used in the Kiddy Copter was directly below the rotor head.

## 90) THE ROTOR HEAD AND THE ROTOR BLADES.

One of those difficult questions we had before starting this project was how to simulate the rotor head and rotor blades of this heli. Not being an RC person I thought most RC items were small handheld aircraft and much too small for this project but to my surprise I found this beautiful machined aluminum Gartt 700 DFC FBL Main Rotor head for a Trex 700 RC helicopter. The copter would now have a convincing 70 inch main rotor.



**91) THE GEARBOX WAS LIFTED HIGHER TO SEND POWER TO THE TAIL.**

The red disk under the gearbox was used to shim the horizontal power output shaft above the tail boom and centered in bearing blocks that would carry the rotational force of the tail rotor shaft. The split in the rear of the red ring is an access way that permits a hex wrench to tighten the lower shaft collar on the gearbox.

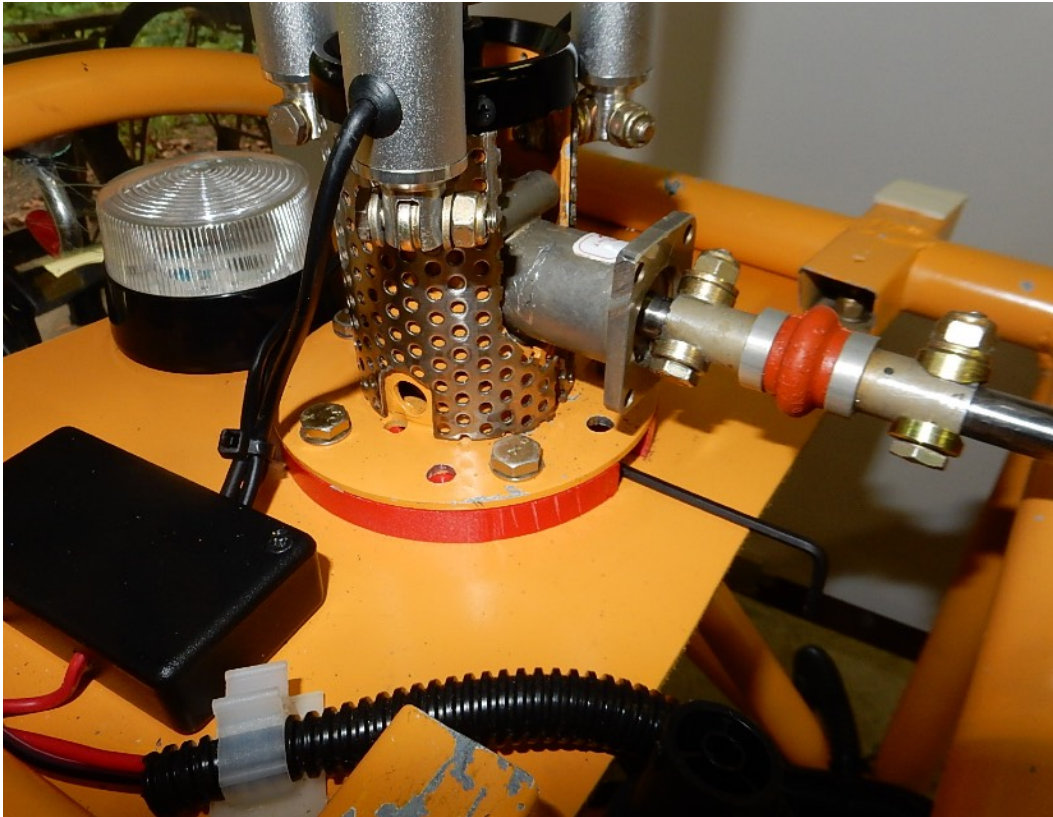

Close up of the gearbox right angle take-off shaft connecting to an Apex Universal Helicopter joint. The silicon membrane is the only material connection between the output shaft of the gear drive and the transmission shaft going to the tail rotor. The same as a real Bell 47.



**92) USING SHAFT COLLARS WITH SET SCREWS REQUIRED ACCESSIBILITY.** Safety and serviceability were important for the operation of the Kiddy Copter. All motor, gearbox, and tail power shafts were 3/8" diameter which made it easier to connect and service the shaft collars that connected them together. The European Gantt main rotor head was 12mm so I had to machine an adapter that was connected through a mounting hole. If for any reason someone or something comes into contact with the main or tail rotor the shaft collar pressure set pins will loosen immediately and hopefully prevent any injury or damage.

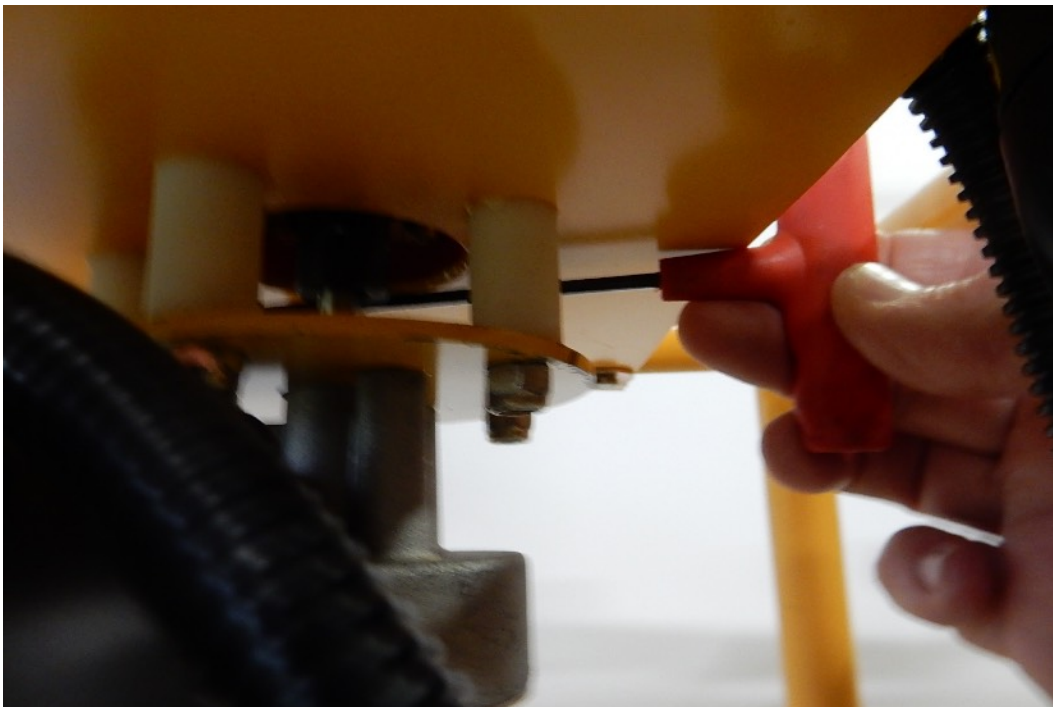

The motor mount was spaced away from the plate above for using a "T" handle hex wrench to adjust set-screw pressure on the lower shaft collar connecting the motor output to the gearbox.

### 93) SIMULATING THE ROTOR SYSTEM.

Making the rotor system function required additional components including the upper stabilizer bar which is the top bar with weighted ends. These were used on the Bell 47 as a mechanical sensor assisting in stabilizing and controlling the pitching motion of the helicopter. Today's helicopters have computers that keep things stabilized. I decided to simulate the stabilizer bar without linking it with complicated levers. The bar we used is a basic die stock tool or wrench used for holding round dies for threading. We added "T" handles on the ends to simulate the weights on the stabilizer bar.



The stabilizer bar sits on top of the rotor head trunnion. It was for visual effect only and there was no mechanical linkages.

#### 94) MAKING THE MAIN ROTOR BLADES FUNCTION WITH A SWASH PLATE

The Gartt Main rotor head has all the functionality of a real helicopter. The three linkages of the rotor head can operate pitch and roll for a RC helicopter. The Kiddy Copter obviously is not going to fly so connecting these linkages was not necessary however we wanted connections to the linkages that would make the rotor head look functional and be semi functional to a degree. We decided to make the collective lever operate a swash plate on the main rotor mast that would extend three lifters simultaneously and make the main rotor blades tilt. This would be a great way to teach kids the basics of how a helicopter creates lift.



When the collective lever is raised the three electric lifters retract and pull the three rotor head connection points down simultaneously causing the main rotor blades to tilt in a high angle of attack required for lift off.



### 95) MAKING THE COLLECTIVE RAISE AND LOWER THE SWASH PLATE.

The collective lever is located on the left side of the cockpit. In a real helicopter the handle also has a throttle much like a motorcycle throttle and controls the RPM of the rotor. We simulated this with a foam grip attached around a linear bearing. The other switches on the collective are for show only. The problem I had was how to make the three electric lifters raise and lower when the collective lever is raised and lowered and make the swash plate move. Tony had a brilliant idea and he devised a set of four limit switches that when contacted with the lever mechanism would raise or lower the lifters and thus make the swash plate move along with the main rotor blades.

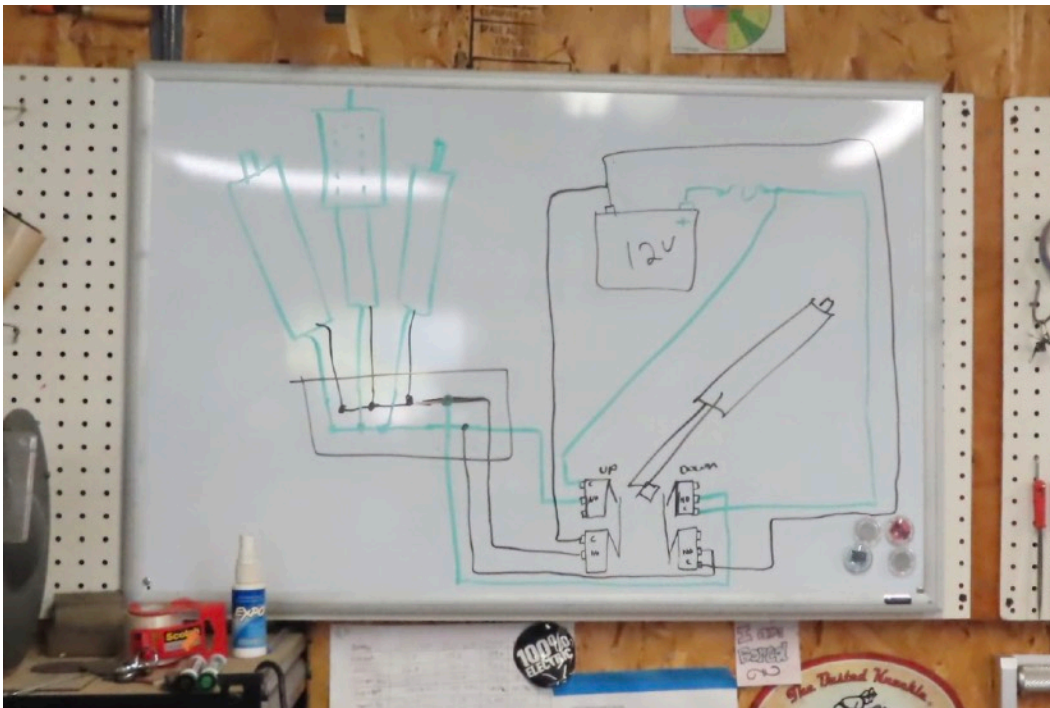

Tony made this sketch on how to use four limit switches and wire them in a circuit that would allow the mechanical collective lever to activate the three 12 volt lifters simultaneously and make the swash plate raise up or down making the main rotor blades tilt in a low or high angle of attack.

**96) HOW TO LINK THE COLLECTIVE LEVER TO THE LIMIT SWITCHES.**

We used a mechanical link from the collective lever that would swing an arm and make contact with each pair of limit switches. This mechanism was located directly under the seat and cannot be seen.

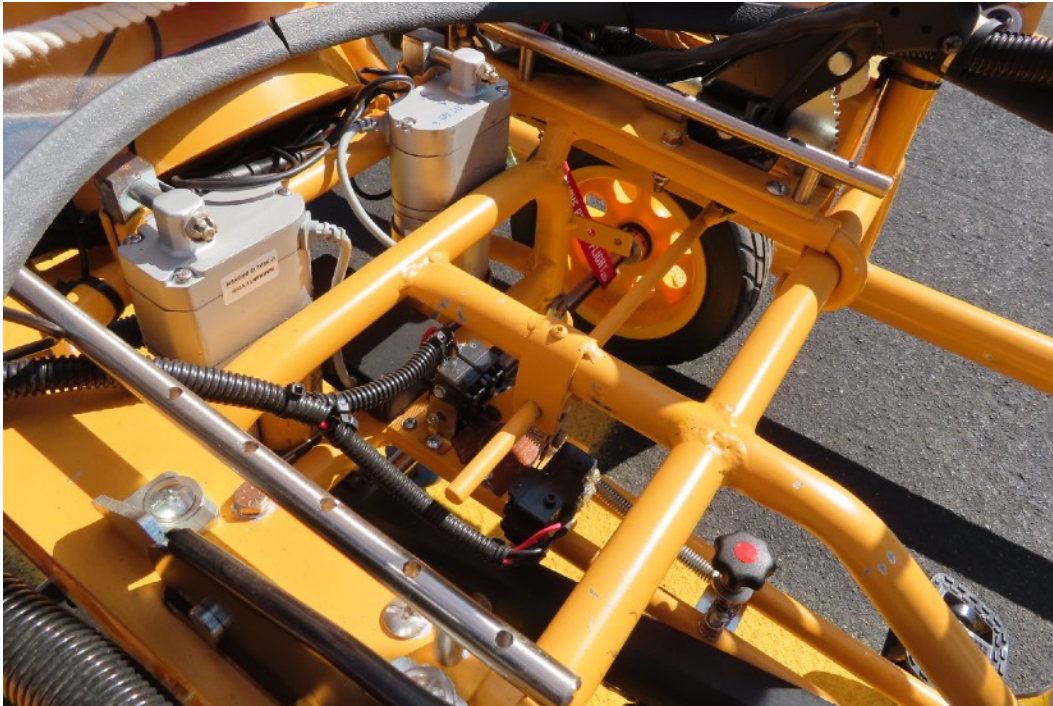

With the seat removed, the mechanical linkage can be seen from the side of the collective lever over to a swing arm that makes physical and electrical contact with a pair of limit switches on the front side and when lowered makes physical and electrical contact with the other pair of limit switches on the rear side.

### 97) THE TAIL ROTOR SET UP.

The right angle gear box rests on a red saddle block machined to fit over the first terminator tube. The saddle block keeps the horizontal power shaft in line with the forward gearbox. Shaft collars were used to connect the power shaft and the tail rotor prop.

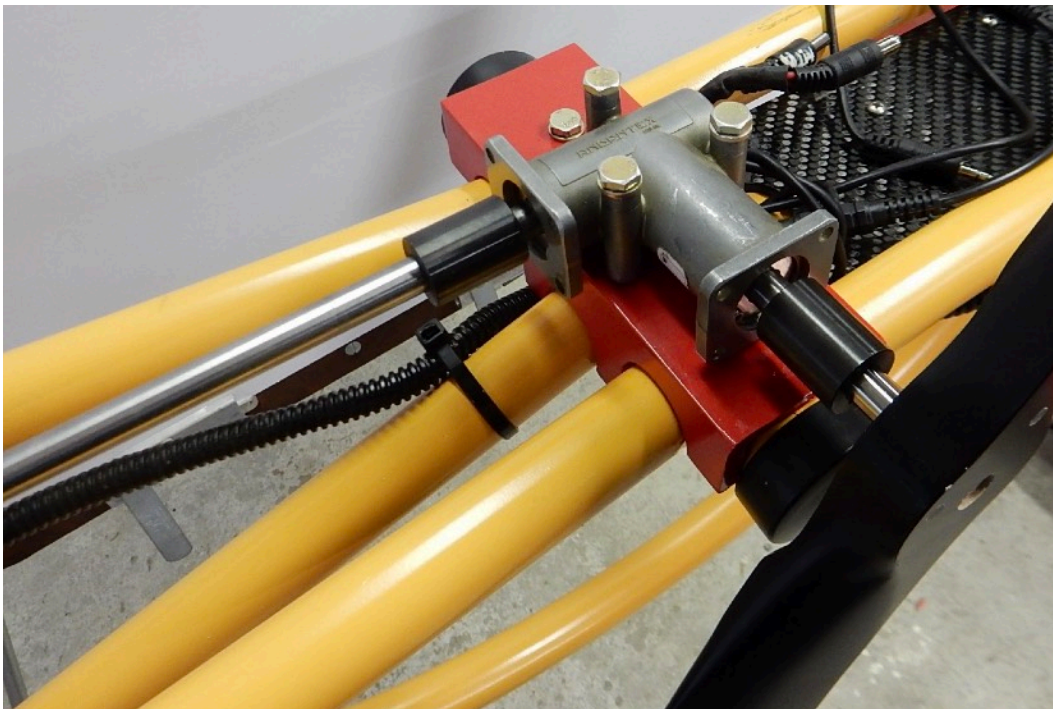

Behind the gearbox is the operator control tray.



**98) THE TAIL POST OPERATOR CONTROL TRAY.**

The two parallel tubes form an area with a small carbon fiber floor or tray that will house the motor speed controller and MP3 player and 20 watt amplifier. For safety reasons the only way the motor can be controlled is by an adult who is pushing the copter and who can monitor who is standing or walking too near the rotor system while it is operating.

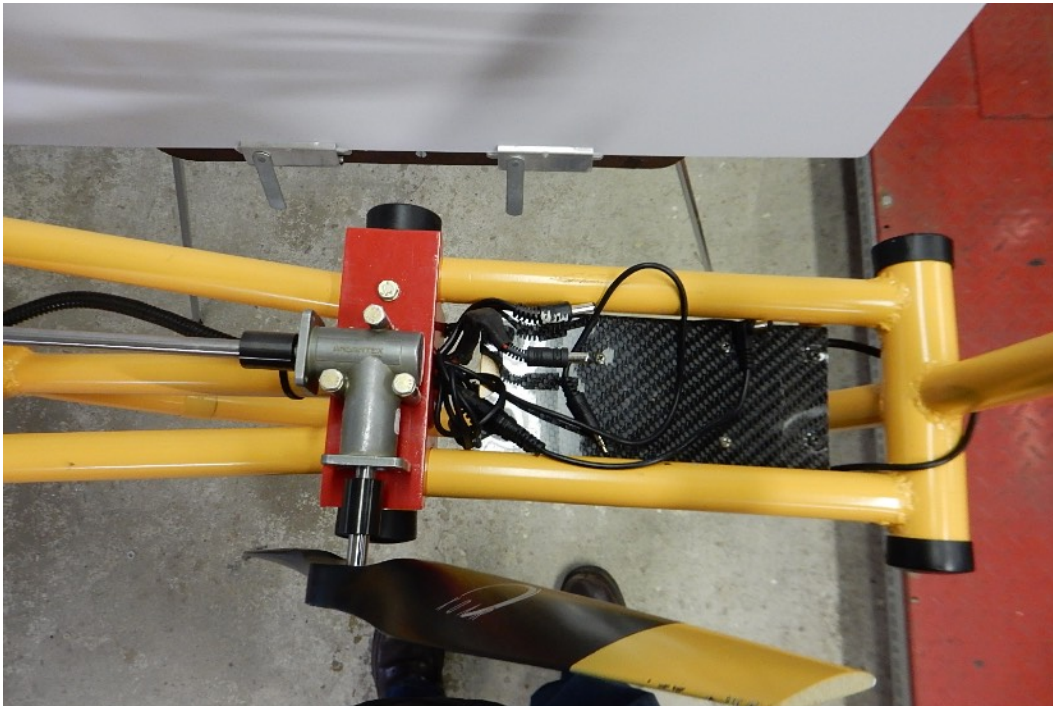

Looking down at the tail rotor area shows the operator control tray that will house the motor speed controller, MP3 player and amplifier.

**99) THE “T” STEERING AND PUSH HANDLE.**

The best way to give a ride in the Kiddy Copter is to push the kid pilot from the tail posts steering and push handle. The Kiddy Copter becomes essentially a big stroller. The operator has to be aware of the spinning tail rotor as it turns very close to where you are holding on to the handle but a little practice and you can avoid a problem.



The controls on the “T” handle are for operating the lift actuators. The buttons operate both lifters equally and together in up down or stop movements.

**100) MY YOUNGEST GRANDSON TAKES A RIDE IN THE KIDDY COPTER.**  
Bradley just turned one year old a week before this picture was taken and also just learned to walk. He is without a doubt our youngest pilot. What's amazing is that he took right to it, holding the cyclic, moving the switches and having a great time. A couple more years from now and Bradley can reach the pedals.



I'm getting ready to give my youngest grandson Bradley his first ride in the Kiddy Copter. He's just turned One!  
Kids up to seven years old can ride the Kiddy Copter.



**101) MY YOUNGEST TONY, WHO HELPED ME BUILD THE KIDDY COPTER.**  
It's time to enjoy our completed projects! Tonys recent Nissan powered electric motorcycle which he designed and built himself and our Kiddy Copter project that we built together.



Tony has built four various style electric motorcycles.

**102) THE KIDDY COPTER JOINS THE KIDDY CUB COLLECTION.**

With all the parades and events canceled due to the pandemic we are looking forward to bringing our fleet to Maker Faire and local parades and other family events next year.



The Kiddy Cubs and Copter Flight Team.

**103) THE KIDDY COPTER WARMING UP FOR FLIGHT.**

The Kiddy Copter is finished and ready to come to an event near you. What we enjoy most is seeing the smiles and happy faces of our kid pilots and watching their parents take pictures for their family memories.



Hope to see our Kid pilots soon!



**104) FAREWELL FROM THE BUILDERS AND DESIGNERS .**

Thank you for giving us this opportunity to tell our story and show our pictures.



Farewell for now!  
The Helmholtz's



