

[Intra-cluster response model and parameter for channel modeling at 60GHz]

Date: 2009-09-23

Authors:

Name	Affiliations	Address	Phone	email
Hirokazu Sawada	Tohoku University	2-1-1 Katahira, Aoba-ku, Sendai 980-8577, JAPAN	+81-22-217-6112	sawahiro@iec.tohoku.ac.jp
Shuzo Kato	NICT/ Tohoku University	3-4, Hikarino-Oka, Yokosuka, Kanagawa 239-0847 Japan		shu.kato@nict.go.jp
Katsuyoshi Sato	NICT	3-4, Hikarino-Oka, Yokosuka, Kanagawa 239-0847 Japan		satox@nict.go.jp

Abstract

[This document describes intra-cluster channel models and antenna beam width effect for TGad channel modeling.]

- 1. Proposals of intra-cluster channel models for living, conference and cubicle environments**
- 2. Antenna beam width effect analysis on the intra cluster parameters**
- 3. Inter cluster parameter analysis based on measurement results are started**

Current status of channel models and **this contribution**

Environments		Inter cluster channel modeling	Intra cluster by measurements	Dual polarization feasibility
Conference	Previous works	Done by ray trace simulation	Done	Done Conclusion?
	Team of Tohoku Univ. and NICT	Measurement: Done Modeling:	Measurement: Done Modeling: Done	Done Linier pol.: STA-STA OK AP-STA ? Potable device-AP, STA: NG Circular pol.: STA-STA OK AP-STA OK Potable device-AP, STA: NG
Living	Previous works	Not yet	Not yet	Not yet
	Team of Tohoku Univ. and NICT	Measurement: Done Modeling:	Measurement: Done Modeling: Done HPBW analysis: Done	Done Linier pol.: OK Circular pol.: OK
Cubicle	Previous works	Not yet	Not yet	Not yet
	Team of Tohoku Univ. and NICT	Measurement: Done Modeling:	Measurement: Done Modeling: Done	Done Linier pol.: STA-STA OK AP-STA ? Circular pol.: STA-STA OK AP-STA OK Potable device-AP,STA: NG

Difference between previous works and TU&NICT measurements

	Previous works	Tohoku Univ. and NICT
Bandwidth	800MHz	3GHz (Required for multi Gbps transmission)
Environment	Conference	Conference Living Cubicle
Antenna※	17deg (18dBi)	In conference room <ul style="list-style-type: none"> • 30deg (16dBi) for STA • 60deg(10dBi) for AP In living room <ul style="list-style-type: none"> • 5, 30, 60, 90 deg In cubicle <ul style="list-style-type: none"> • 30deg (16dBi) for STA • 60deg(10dBi) for AP
Polarization	Vertical Horizontal Circular(RHCP, LHCP)	Vertical Horizontal Circular

※Evaluation methodology defined the maximum antenna gain 14dBi

Measurement procedure and results in living room

Measurement system

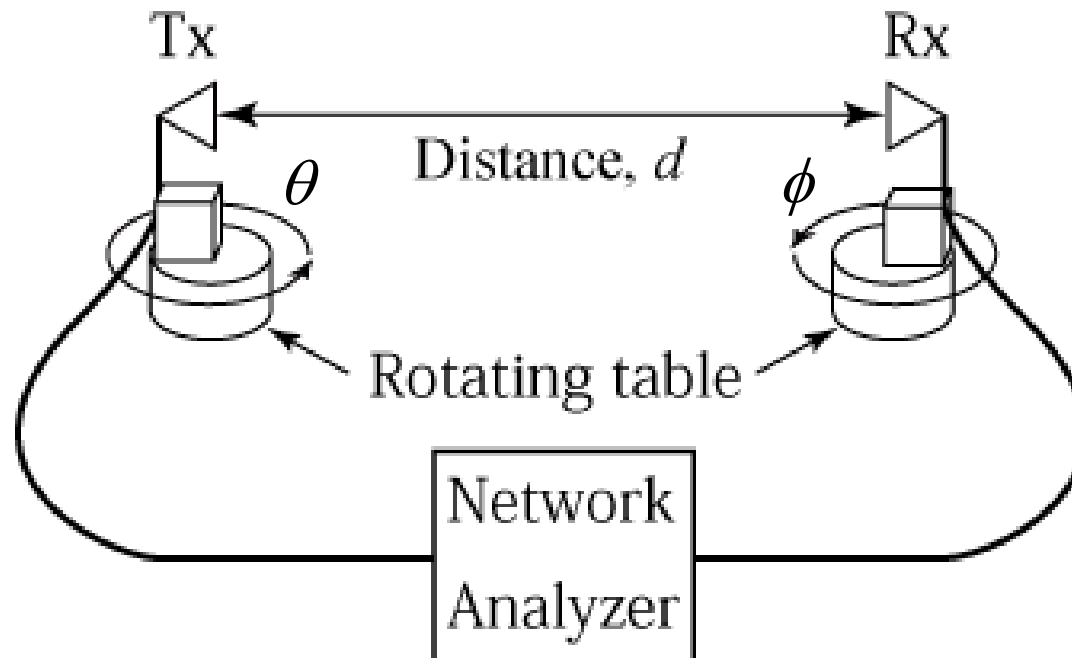

- Instrument: Vector network analyzer
- Antenna: Conical horn antenna

Measurement set up in living room

Parameter	Value
Center frequency	62.5 GHz
Band width	3 GHz
Number of frequency points	801
Frequency step	3.75 MHz
HPBW of antenna (Gain)	30 degree
Polarization	Vertical, Horizontal, Circular
Calibration	Direct port connection without antennas

Floor plan of living room 'defined by TGad'

Antenna height:
1.5m (LoS scenario)
1.0 m (NLoS scenario)

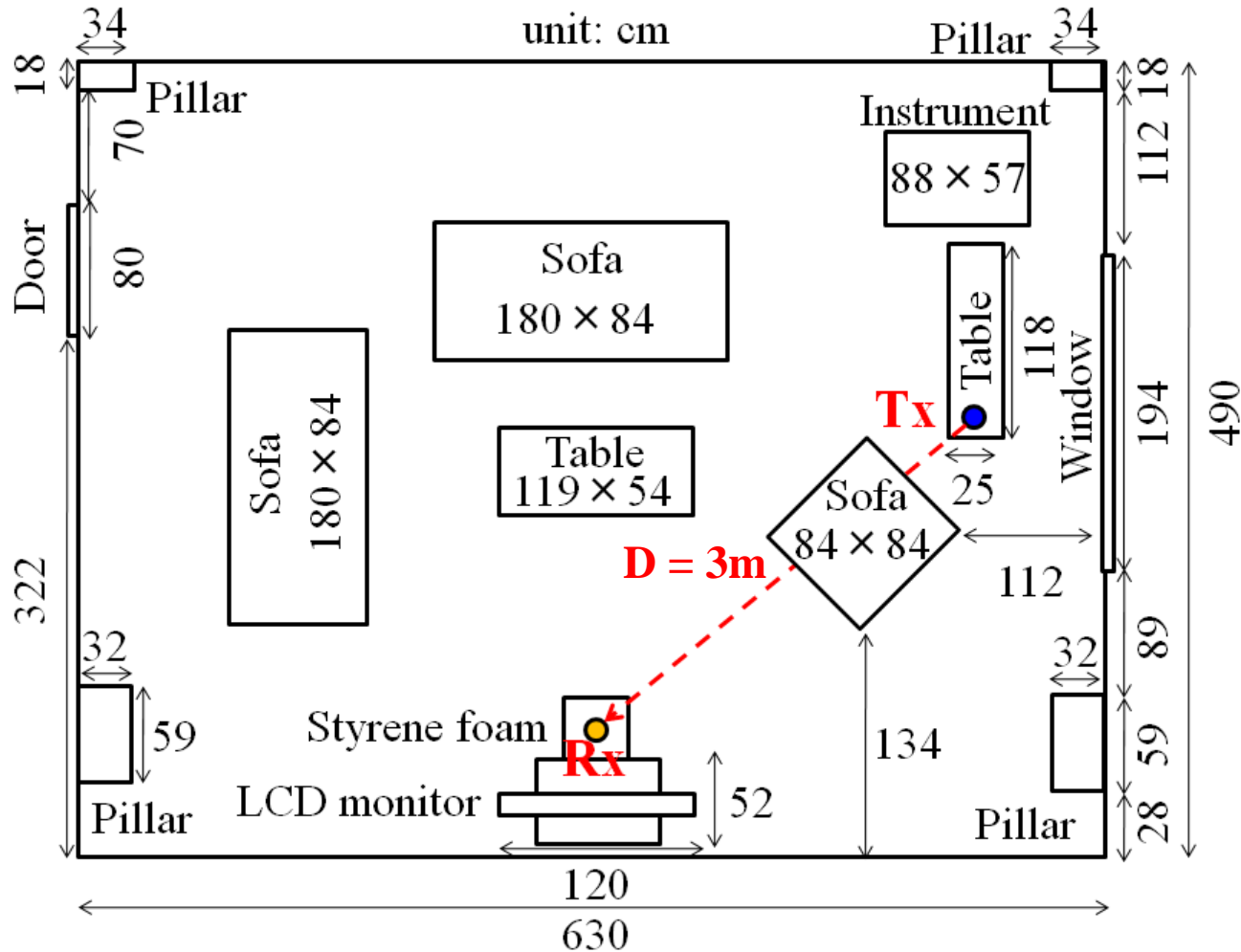

Living room measurement snap shot

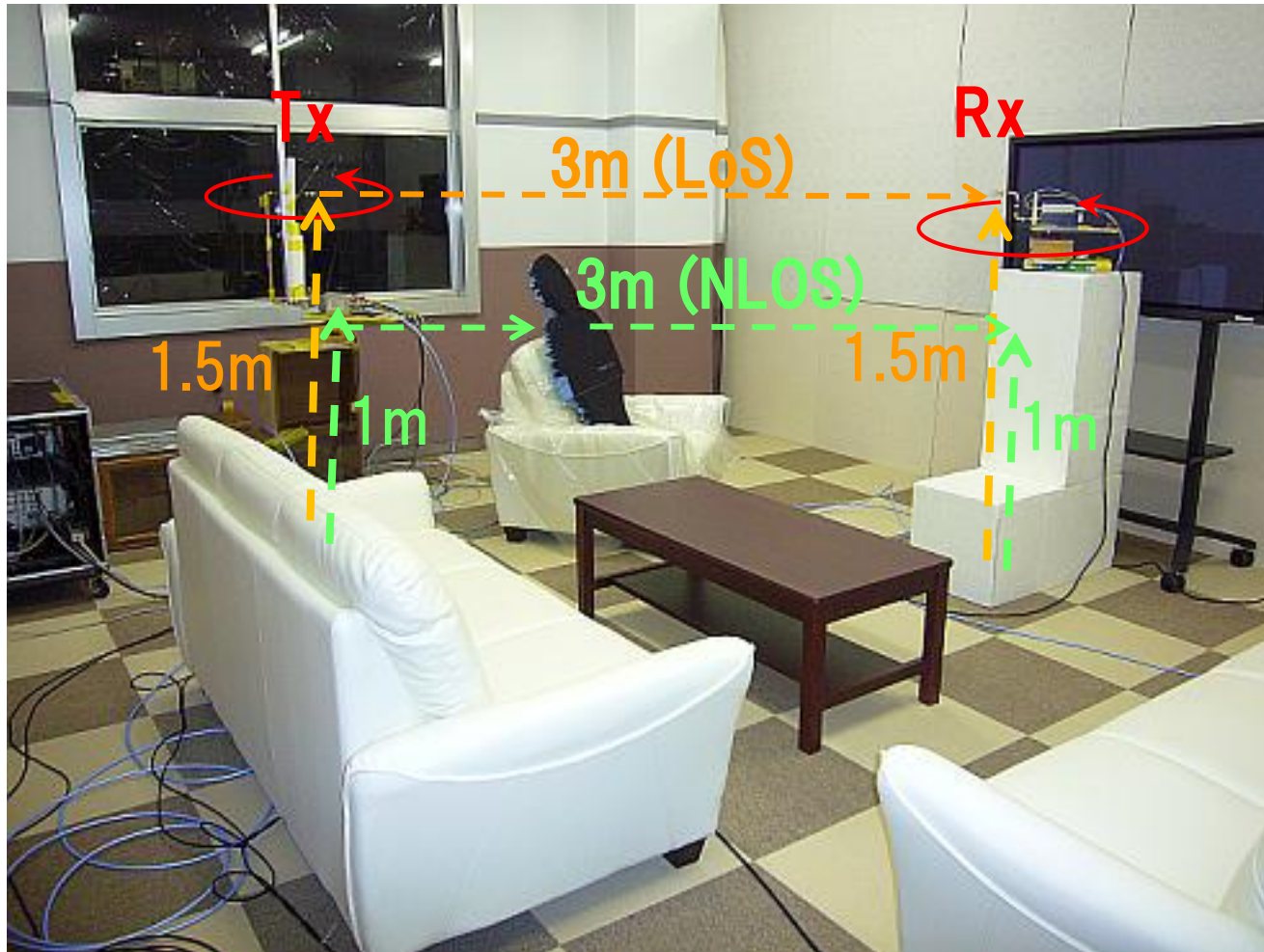

Received power in LOS/NLoS scenarios for co-pol. signal waves (Ref. Doc.09/874)

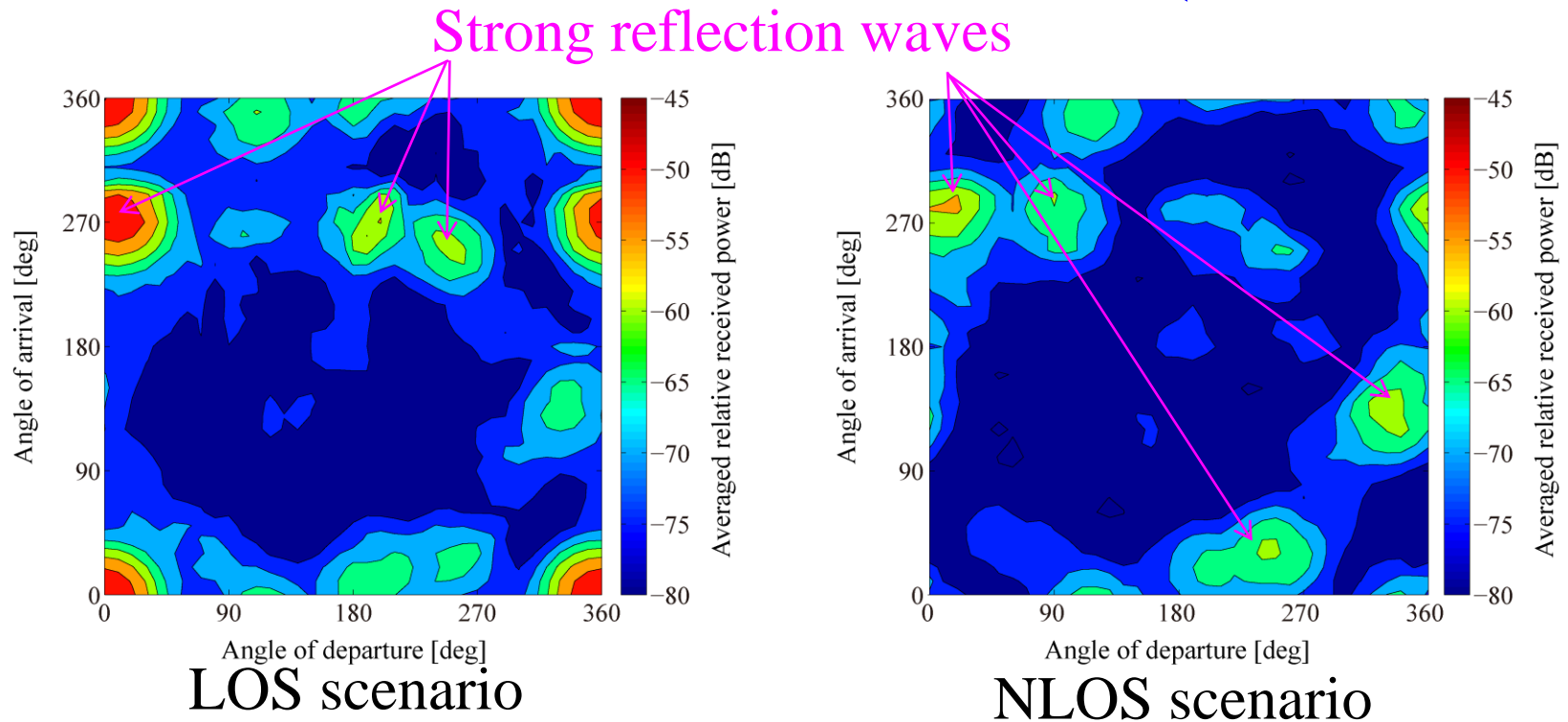

- Strong reflection waves came from $(\text{AoD}, \text{AoA}) = (10^\circ, 270^\circ)$, $(200^\circ, 270^\circ)$, $(250^\circ, 250^\circ)$ in LOS scenario
- In NLOS scenario, LOS component attenuated by human absorber

Examples of strong reflection wave path in LOS scenario

Antenna height:
 1.5m (LoS scenario)
 1.0 m (NLoS scenario)

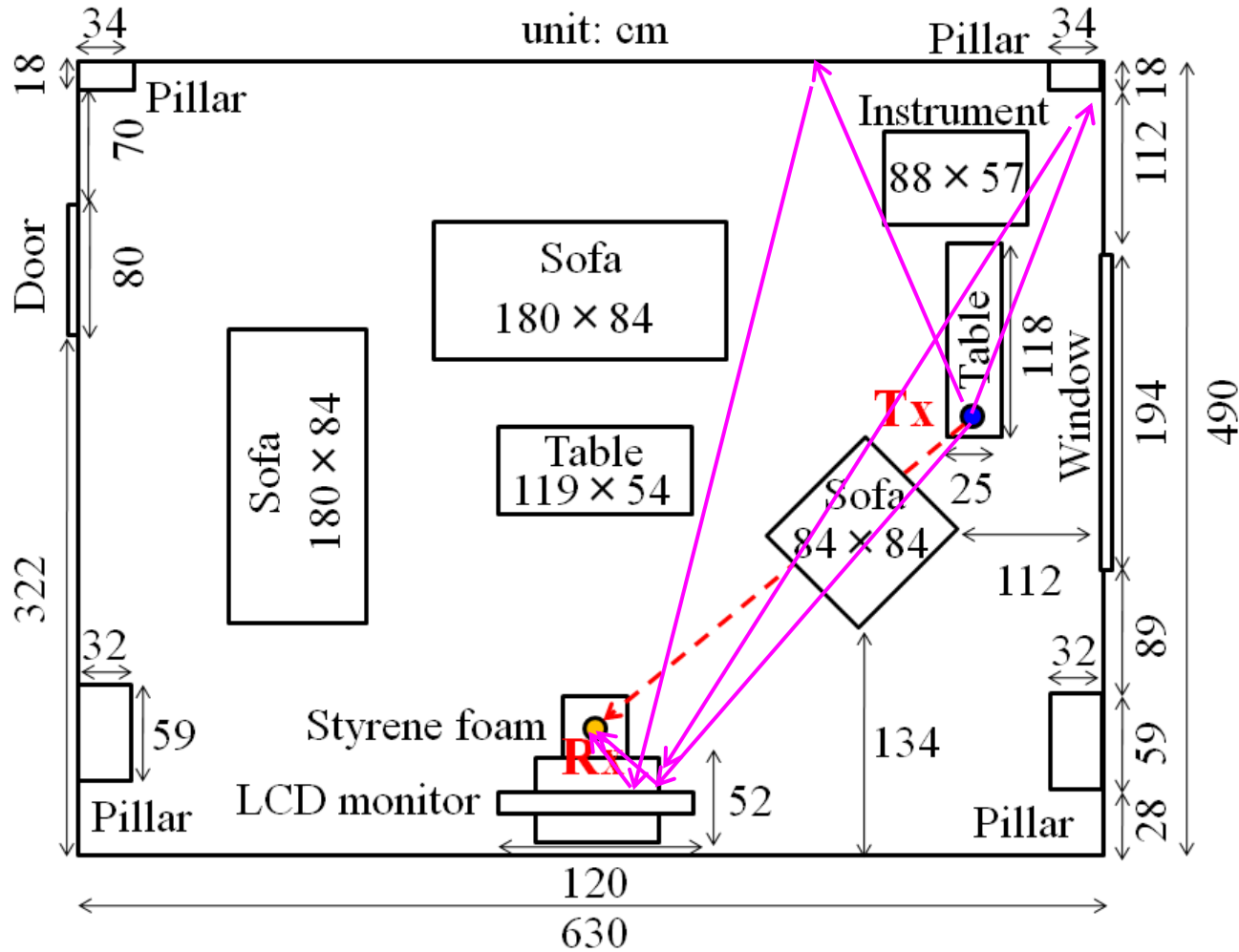

Impulse response example of LOS scenario (V-V) in living room environment

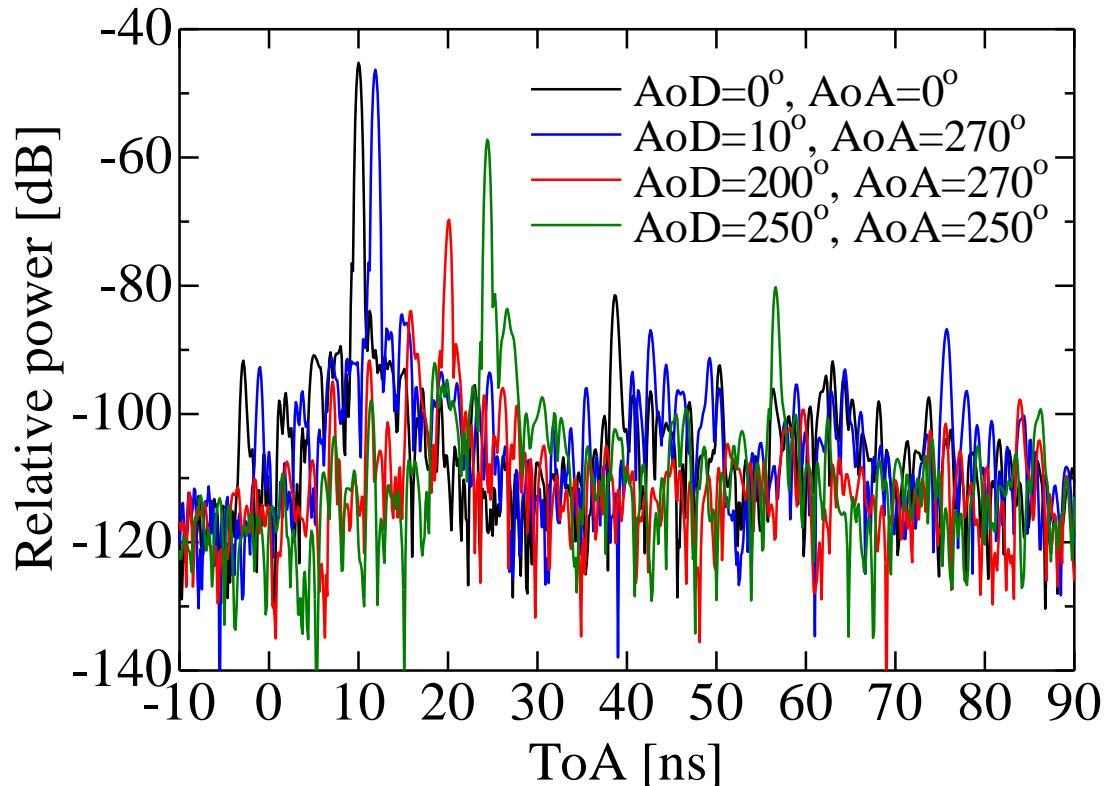

- Top 3 strong reflection responses excluding direct path are selected for intra cluster parameter extraction

Proposed intra-cluster response model

- Two-side exponential decay model
- Ray decay parameter, γ_- and γ_+
- Ray arrival rate, λ_- and λ_+ is assumed as Poisson process

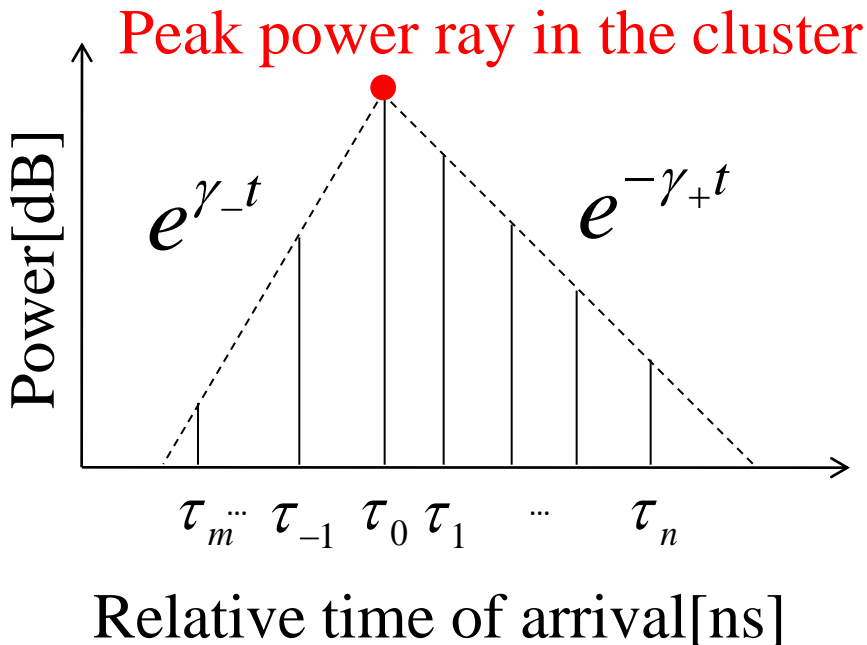

$$h(t) = \sum_m^n \beta_i(\tau_i)$$

$$|\beta_i^2(\tau_i)| = \begin{cases} e^{\gamma_- t} & t < 0 \\ e^{-\gamma_+ t} & t \geq 0 \end{cases}$$

$$P(\tau_{k-1} | \tau_k) = \lambda_- e^{-\lambda_- (\tau_k - \tau_{k-1})}, k < 0$$

$$P(\tau_k | \tau_{k-1}) = \lambda_+ e^{-\lambda_+ (\tau_k - \tau_{k-1})}, k > 0$$

where k denotes the number of rays

Extraction process of ray information

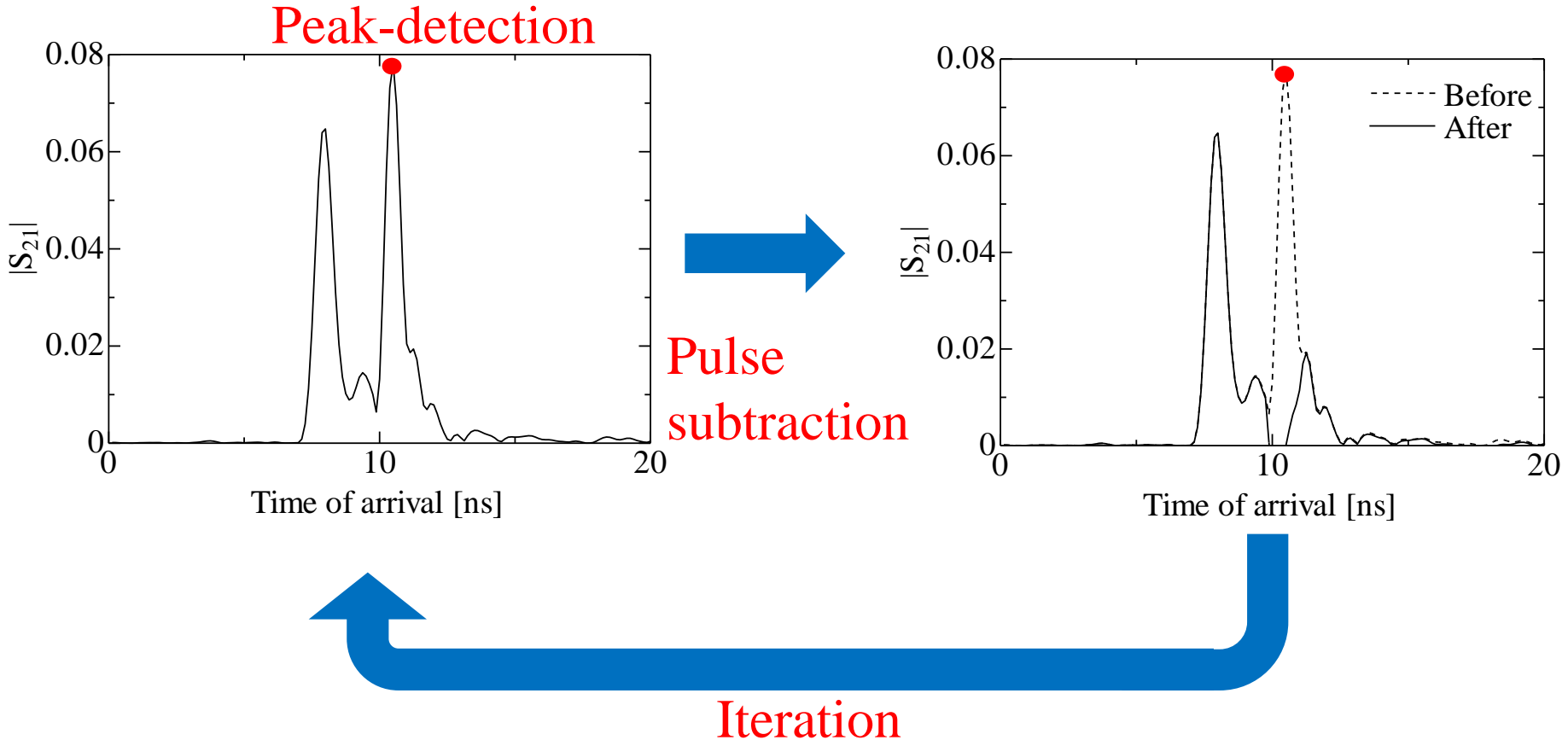

By the iteration of peak-detection and pulse-subtraction, each ray information (Power and ToA) can be extracted

Example of extracted ray information for intra cluster modeling (Living environment)

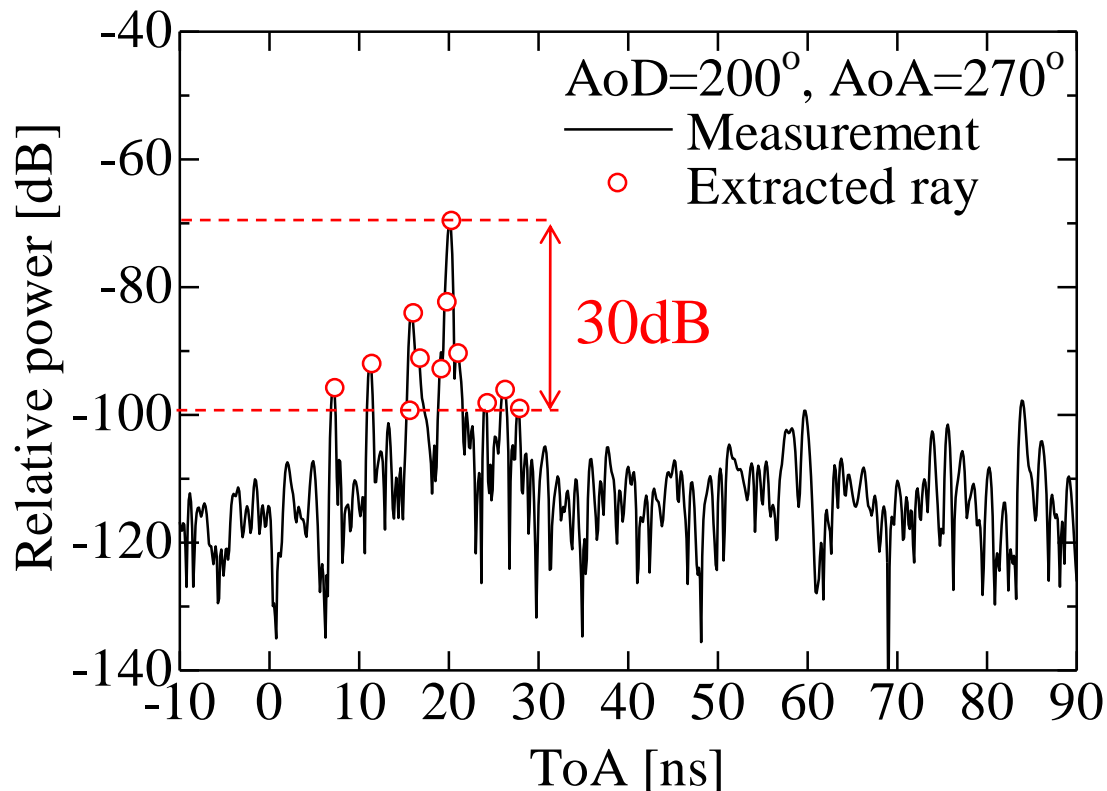

Responses are limited within ± 15 ns by considering the decay slope
Threshold level set to the 30 dB down from the peak power

Example of decay parameter extraction

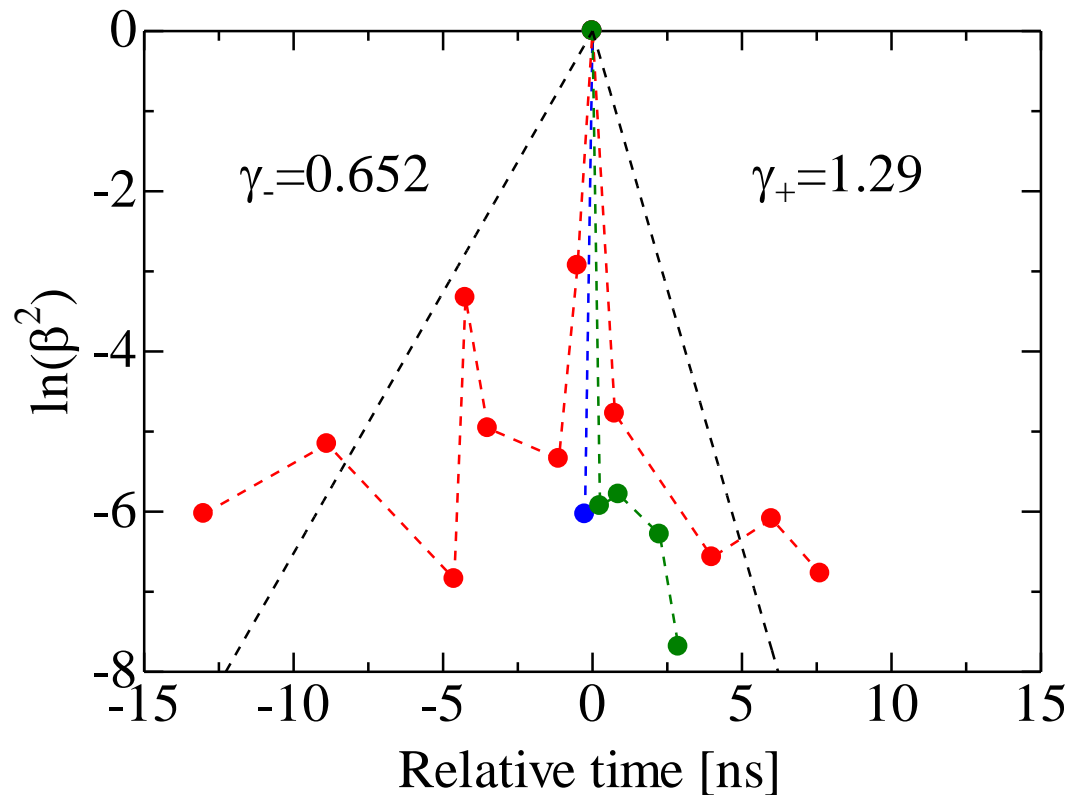

- Decay parameter was extracted by linear fitting

Example of arrival rate parameter

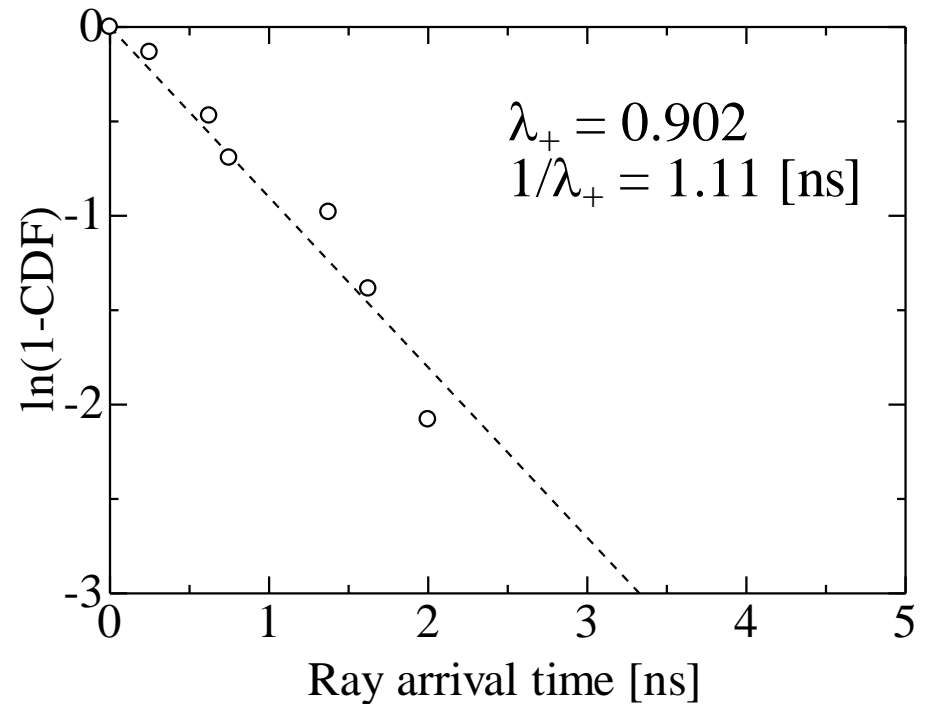
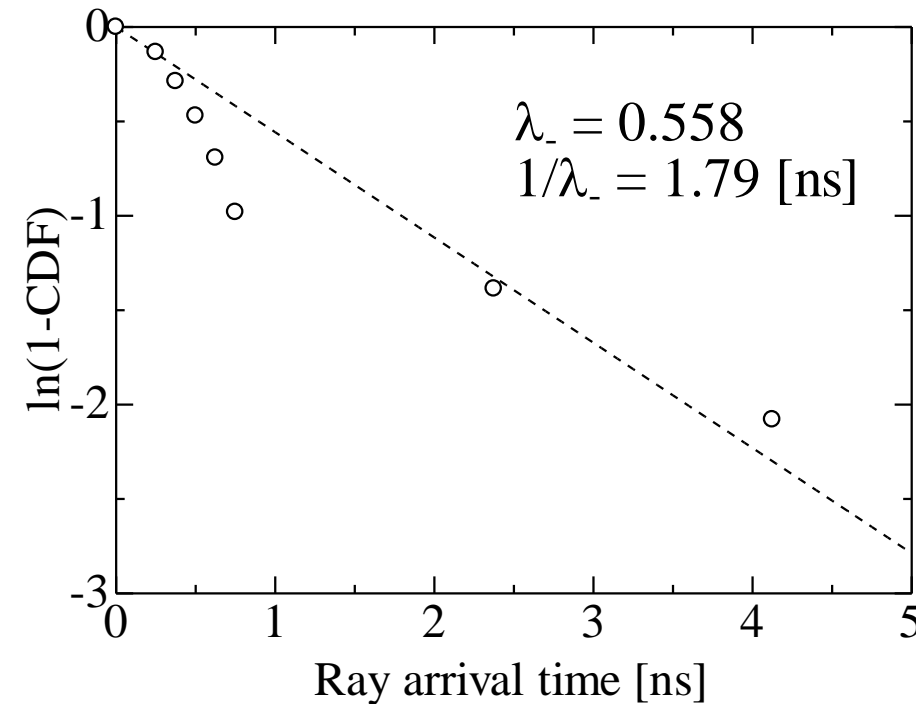

- Arrival rate parameter was also extracted by linear fitting

Intra cluster channel model for living environment (HPBW=30deg)

LoS/NLoS	Pol.	γ_- [ns]	γ_+ [ns]	$1/\lambda_-$ [ns]	$1/\lambda_+$ [ns]
LoS	V	0.652	1.29	1.79	1.11
	H	0.645	1.03	3.63	0.699
	C	0.623	0.854	4.88	0.968
NLoS	V	0.981	2.64	1.46	0.949
	H	2.66	2.14	0.424	0.984
	C	0.891	1.78	0.722	1.28

γ : Decay coefficient

$1/\lambda$ is large: Number of ray is small

Conference room environment “defined by TGad”

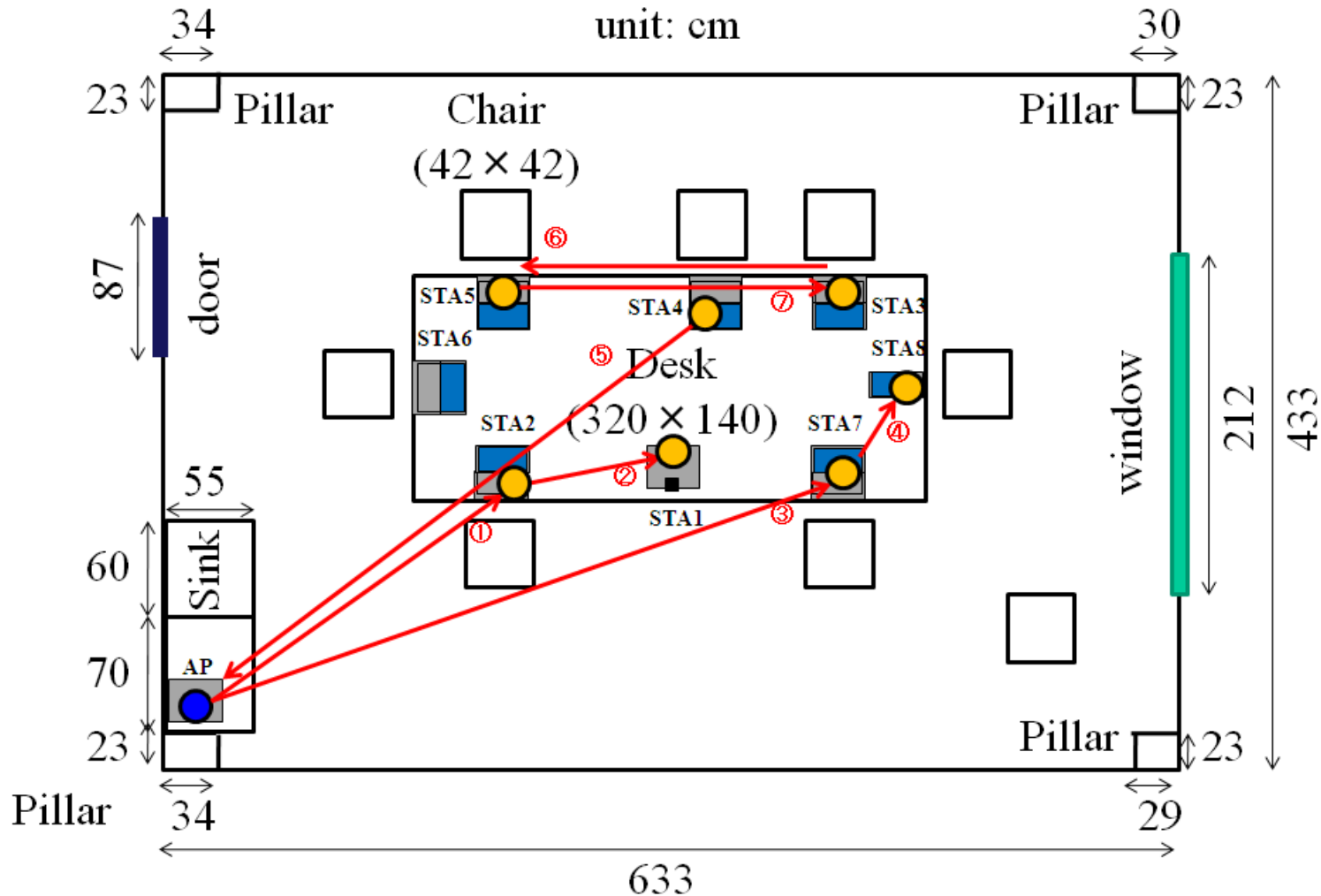

Relative received power of the link 7 (STA5-STA3) (Ref. Doc.09/874)

LOS
scenario

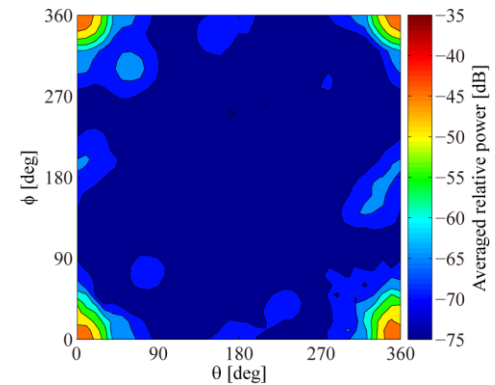
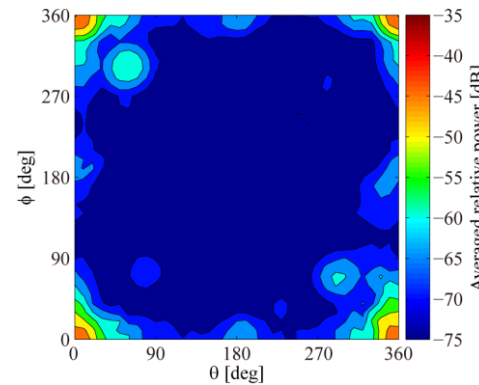
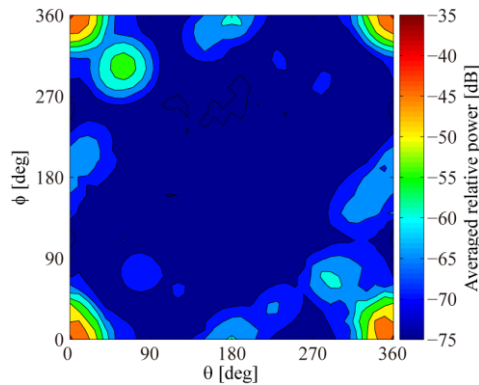

NLOS
scenario

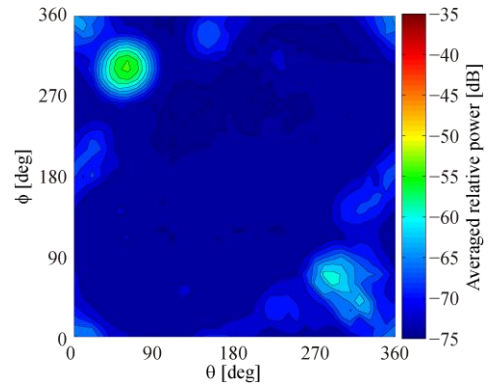
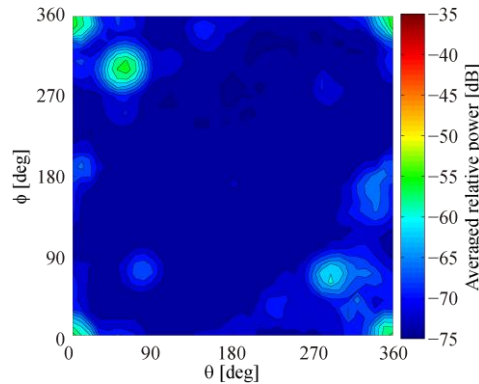
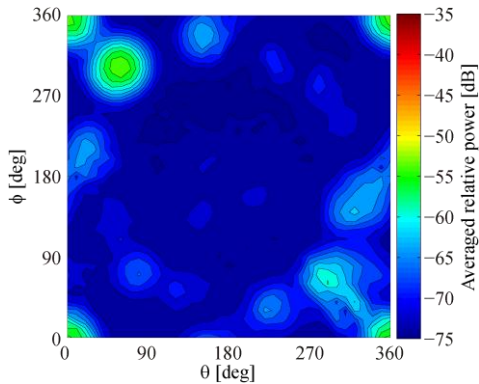

V-V

H-H

C-C

- The reflections from table top was included in the measurements (Ref. Doc. P802.15-06/297r2 slide.5)
- Top 3 strong reflection responses excluding direct path are selected for intra cluster parameter extraction

Intra cluster parameter for conference environment (HPBW=30deg)

LoS/NLoS	Pol.	γ_- [ns]	γ_+ [ns]	$1/\lambda_-$ [ns]	$1/\lambda_+$ [ns]
LoS Link 7	V	0.613	4.11	1.65	1.35
	H	0.510	0.779	2.70	1.92
	C	0.569	0.831	2.02	1.73
NLoS Link 7	V	0.795	0.693	1.25	0.271
	H	0.798	0.853	2.44	1.82
	C	0.967	0.567	0.861	1.77

Including a reflection from desktop
Ref. (Hirokazu Sawada Doc.)

Cubicle office environment “Defined by TG ad (Japanese size office)”

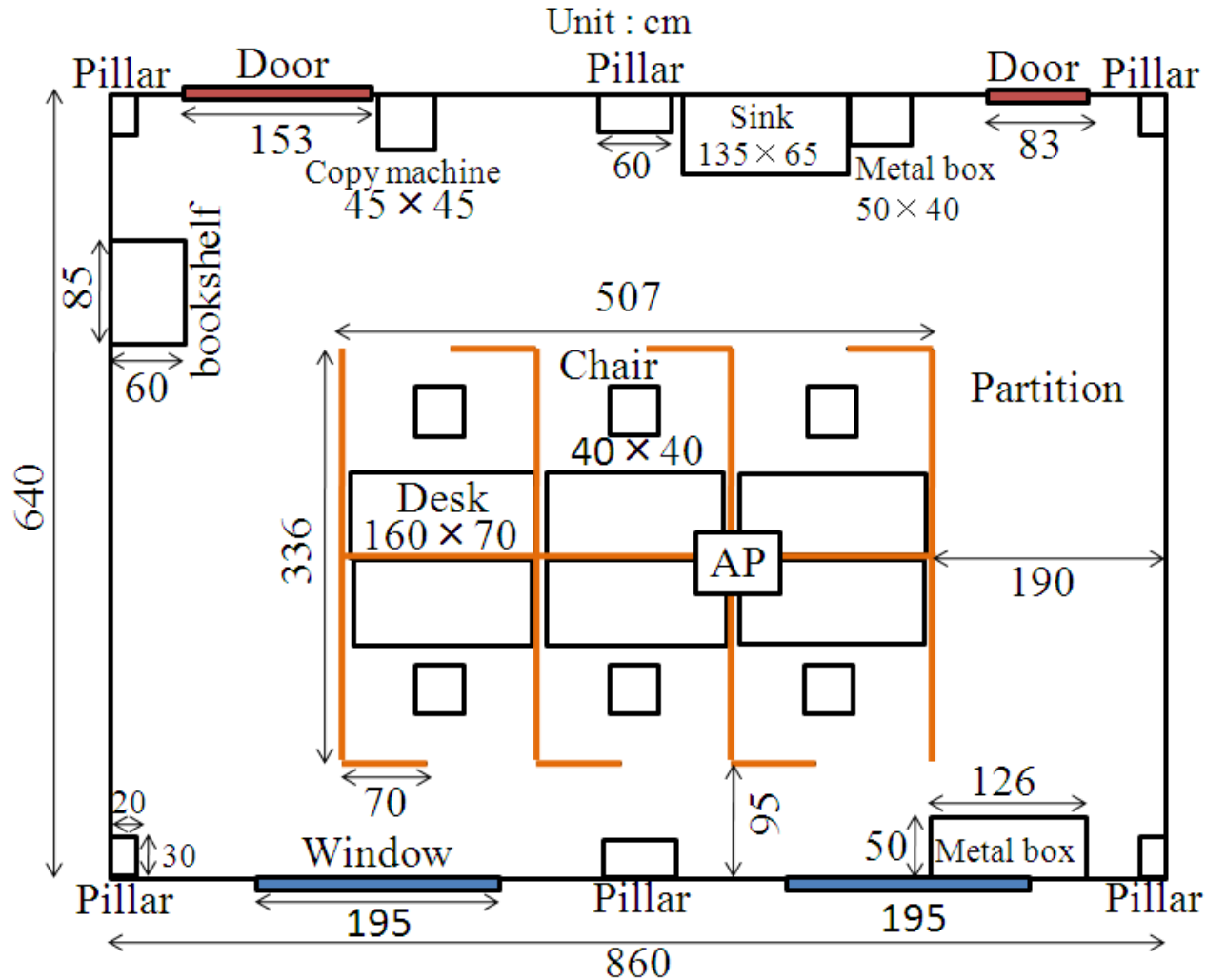

Laptop PC to LCD monitor link

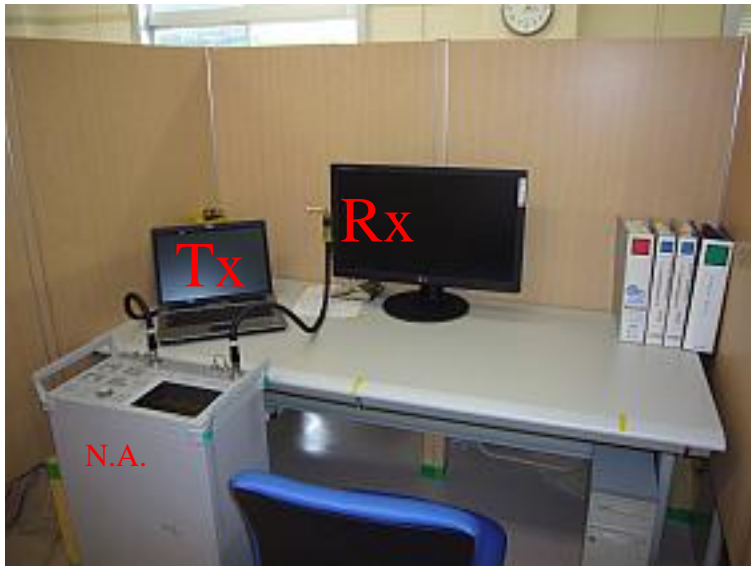

Measurement set up

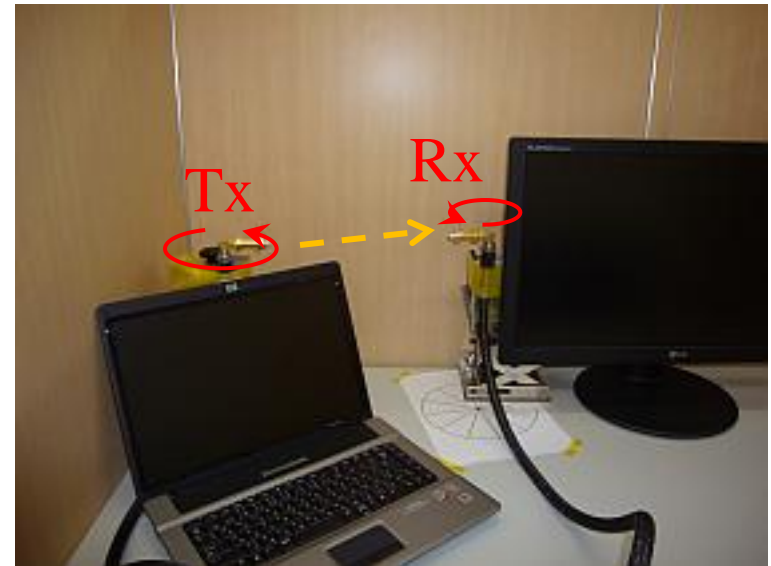

Manually rotation (30deg step)

This is a very short range transmission scenario.

Laptop PC to LCD monitor link

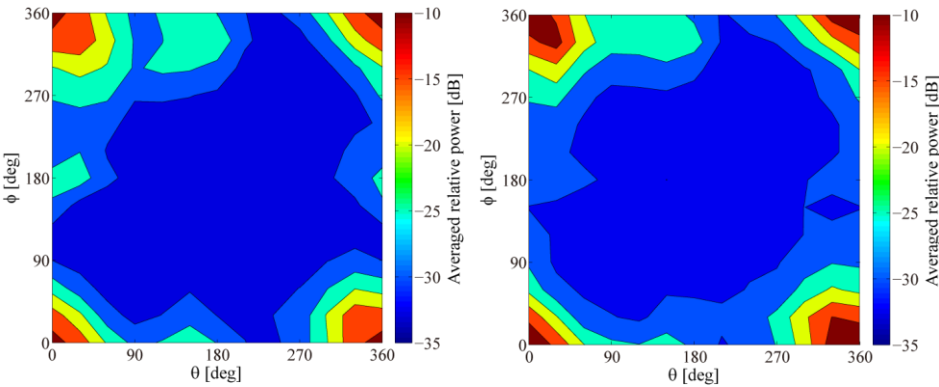

V-V

H-H

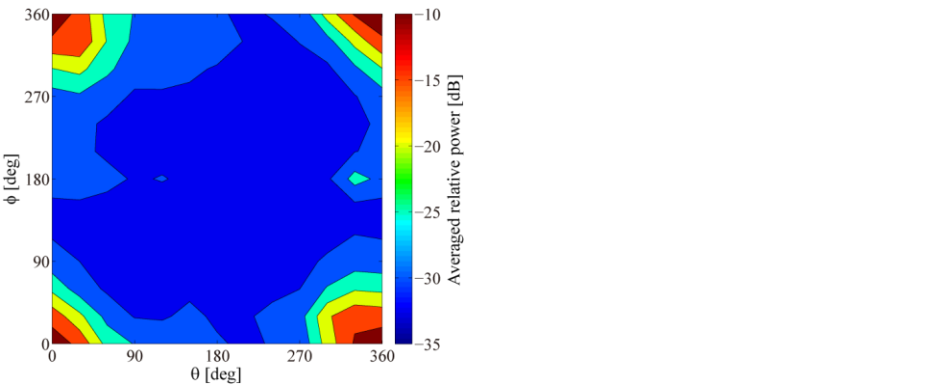

C-C

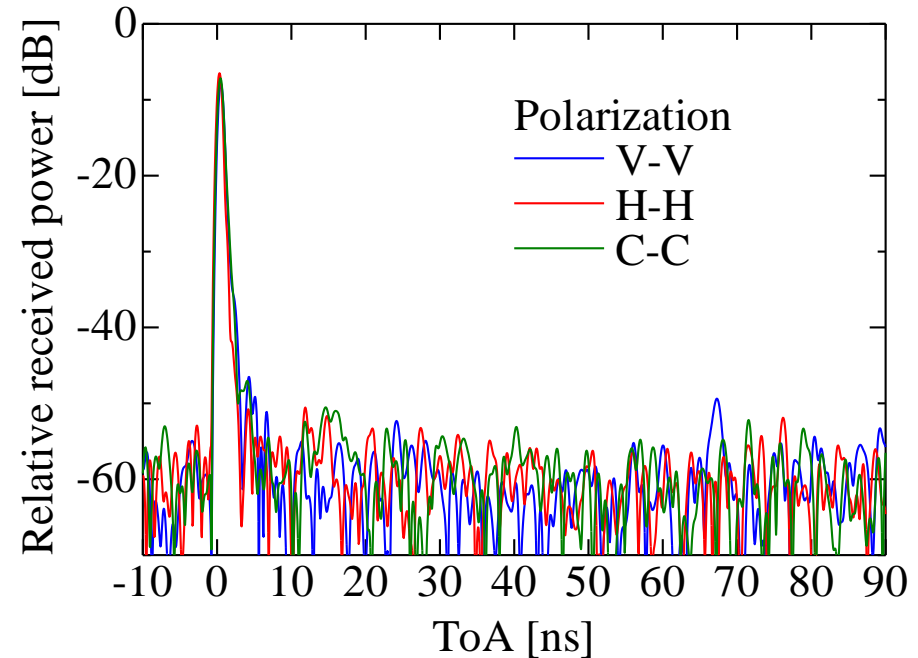

- Direct wave is dominant, significant reflection wave was not observed.
- Channel characteristics is almost AWGN.

Intra cluster parameter (HPBW=30deg, Cubicle environments)

LoS/NLoS	Pol.	γ_- [ns]	γ_+ [ns]	$1/\lambda_-$ [ns]	$1/\lambda_+$ [ns]
LoS	V	0.623	0.731	9.51	2.06
	H	1.87	0.927	0.773	1.31
	C	3.16	0.654	0.627	2.53

$1/\lambda$ is large in cubicle environments: Number of rays is small

AP-STA link

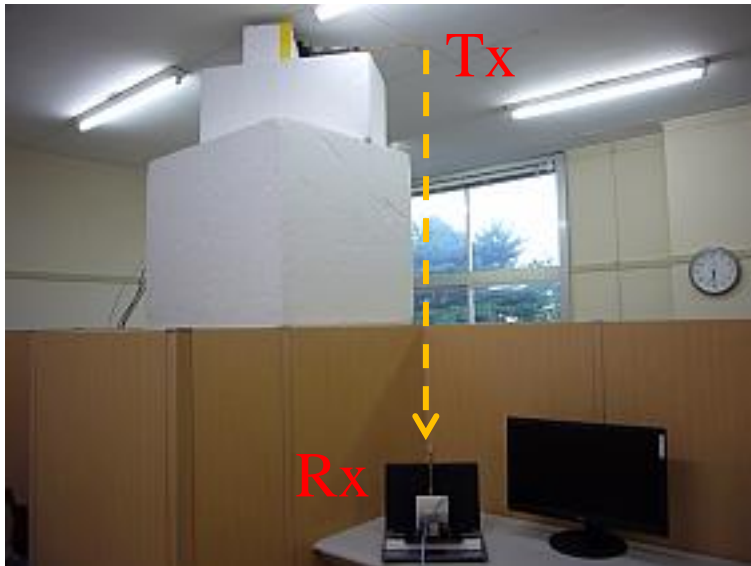

AP-STA Link



Inside of a cubicle

This is a vertical transmission link scenario.

Example of impulse responses for co-and cross-polarized signal waves

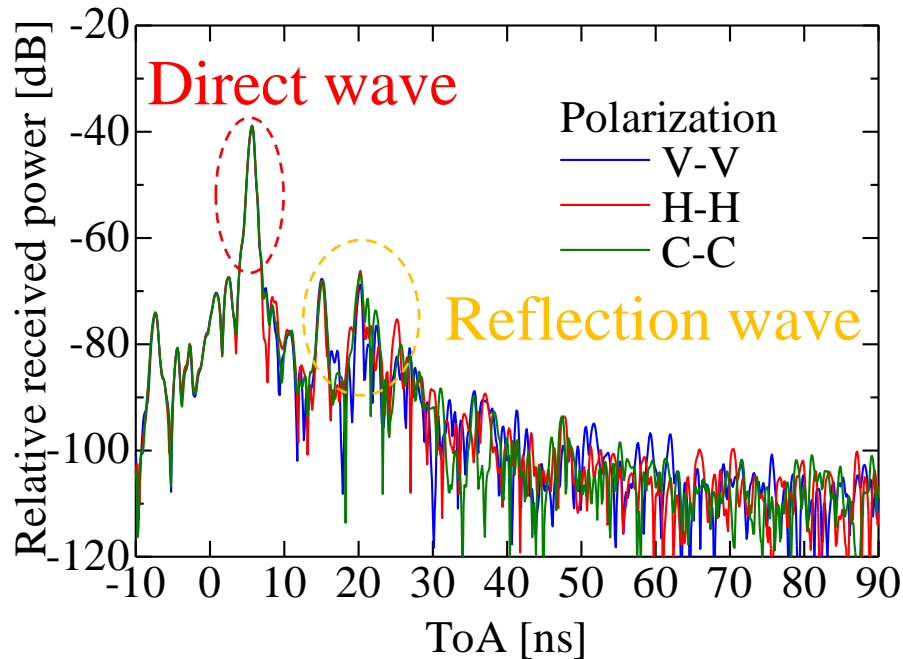

Co-polarized signal waves

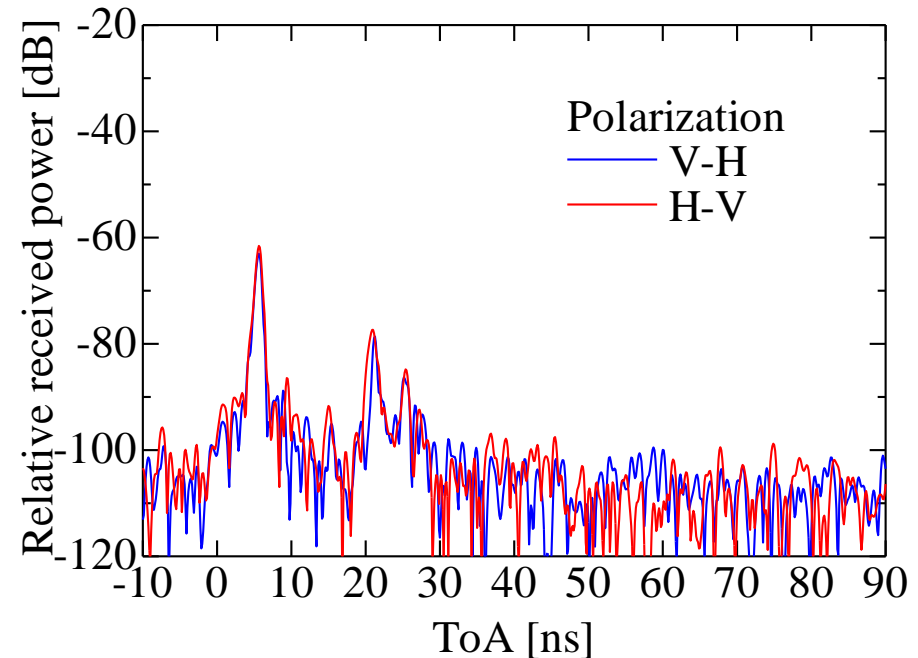

Cross-polarized signal waves

Reflection waves construct cluster, then the intra cluster channel model will be required for AP-STA link too

Effect of antenna beam width to intra-cluster parameter

- Number of rays in the cluster depends on antenna beam width

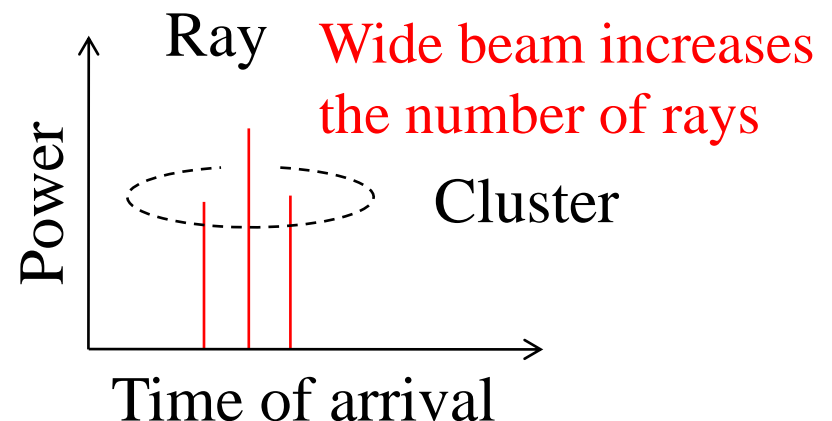
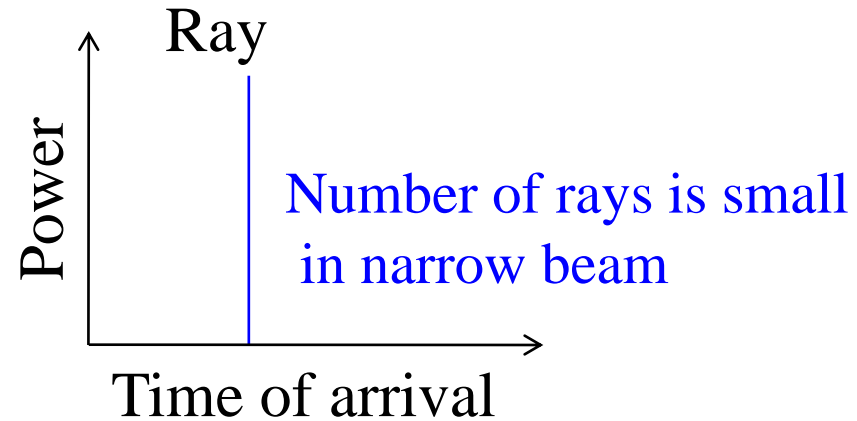
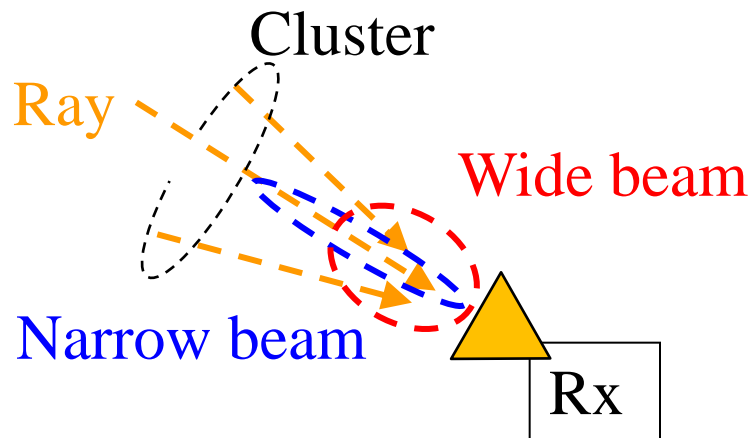

Measurement set up in living room

Parameter	Value
Center frequency	62.5 GHz
Band width	3 GHz
Number of frequency points	801
Frequency step	3.75 MHz
HPBW of antenna (Gain)	5, 15, 30, 90 degree
Polarization	Vertical
Calibration	Direct port connection without antennas

Example of cluster impulse response

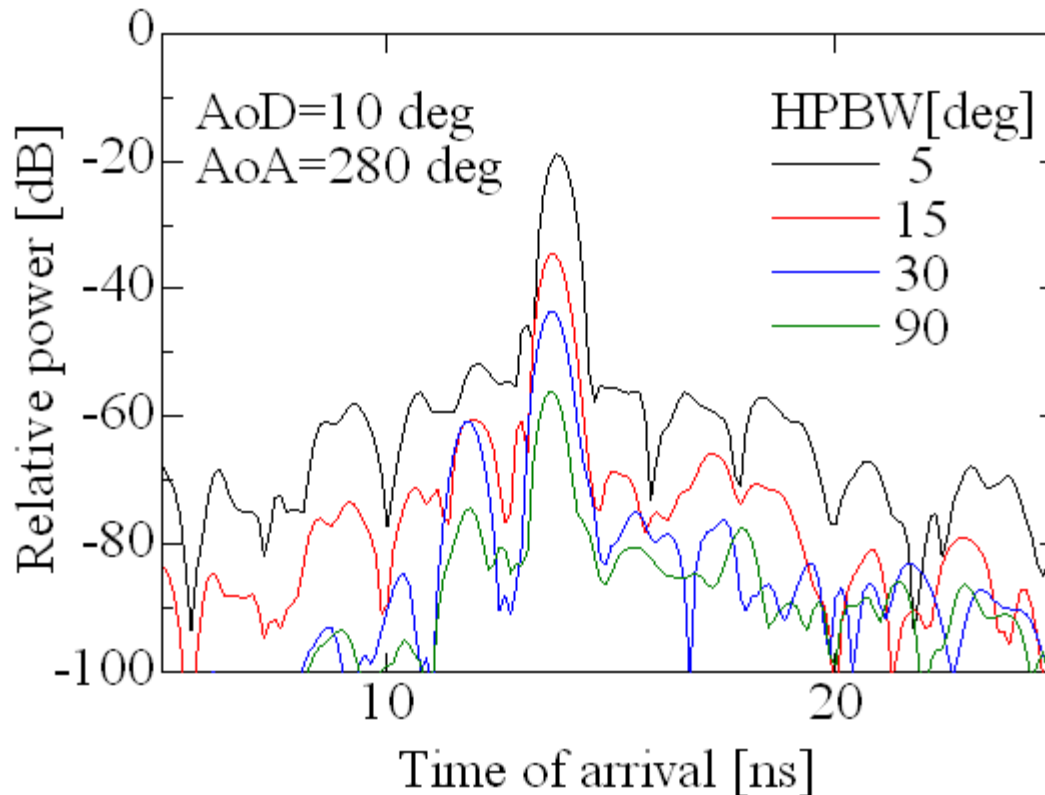

In the figure, the antenna direction was fine tuned to peak power angle for narrow beam.

- Intra cluster response was changed by HPBW of the antenna
- Intra cluster channel models are required for each HPBW

Intra cluster parameter difference against HPBW (Living room environment)

LoS/NLoS	Pol.	HPBW	γ_- [ns]	γ_+ [ns]	$1/\lambda_-$ [ns]	$1/\lambda_+$ [ns]
LoS	V	5	N/A	N/A	N/A	N/A
		15	4.76	N/A	0.902	N/A
		30	0.652	1.29	1.79	1.11
		90	0.795	0.672	1.26	0.690

- Narrow beam did not construct cluster

Inter cluster parameter based on measurements (Living room)

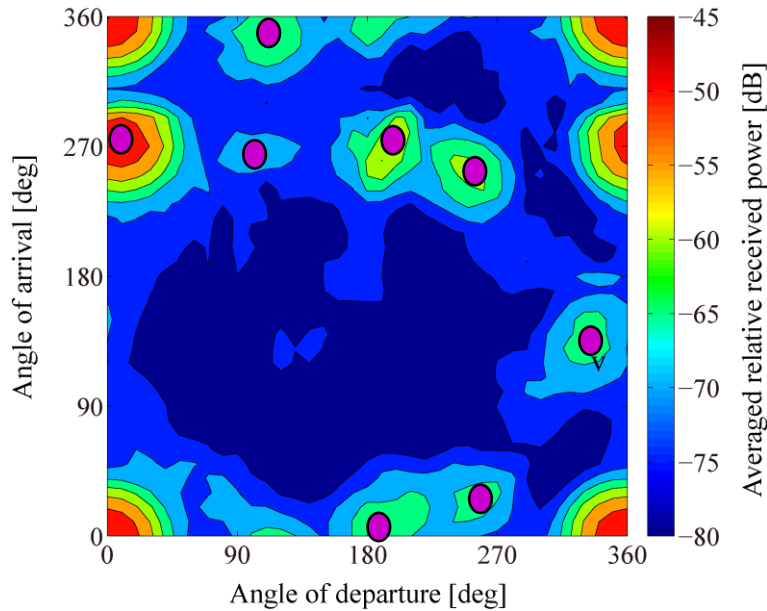

● Cluster included

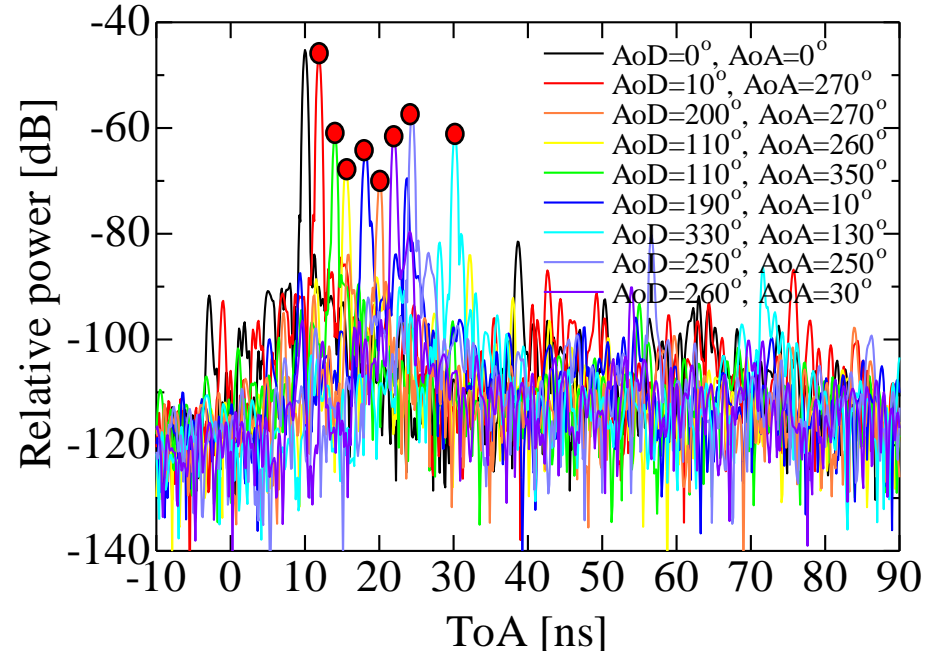

We trying to extract inter cluster channel model parameter for living and cubicle environment

Inter cluster channel model

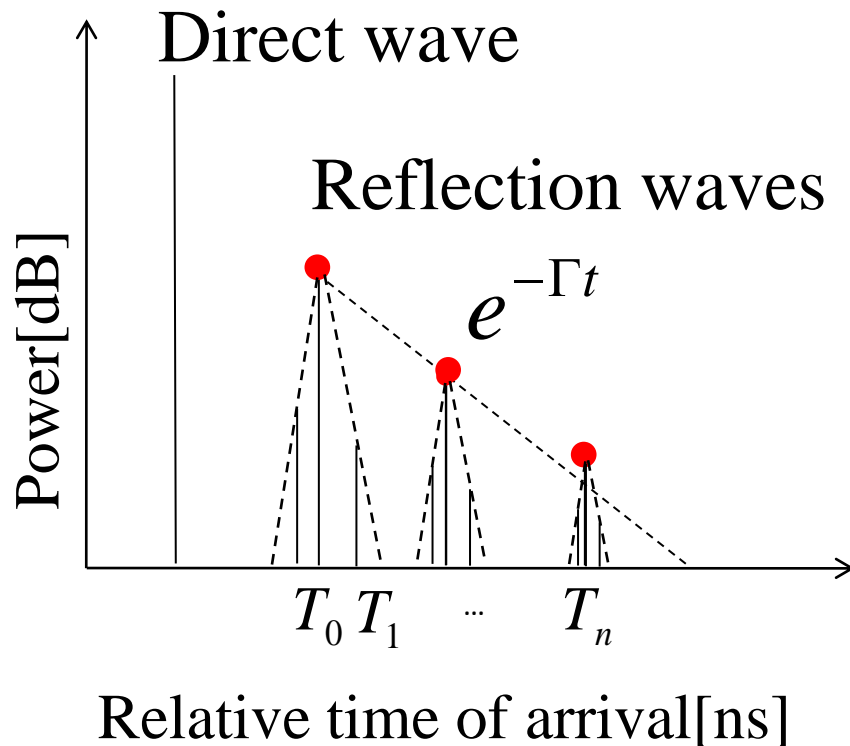

$$h(t) = \sum_m^n \beta_i(\tau_i)$$

$$|\beta_i^2(T_i)| = e^{-\Gamma t}$$

$$P(T_k | T_{k-1}) = \Lambda e^{-\Lambda(T_k - T_{k-1})}, k > 0$$

where k denotes the number of clusters

Example of inter cluster channel model parameter based on measurement results (in Living room)

- Cluster decay parameter, Γ
- Cluster arrival rate, Λ is assumed as Poisson process

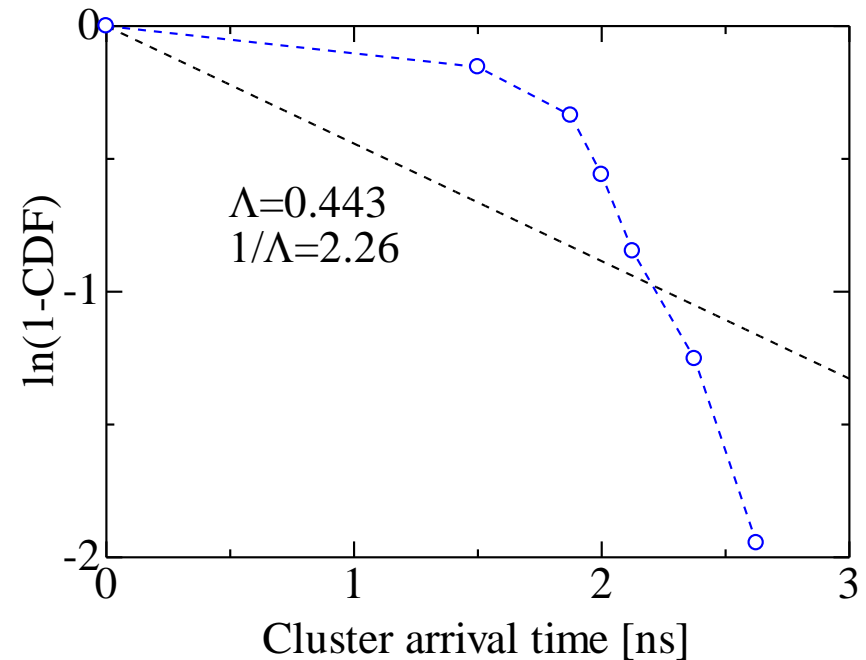
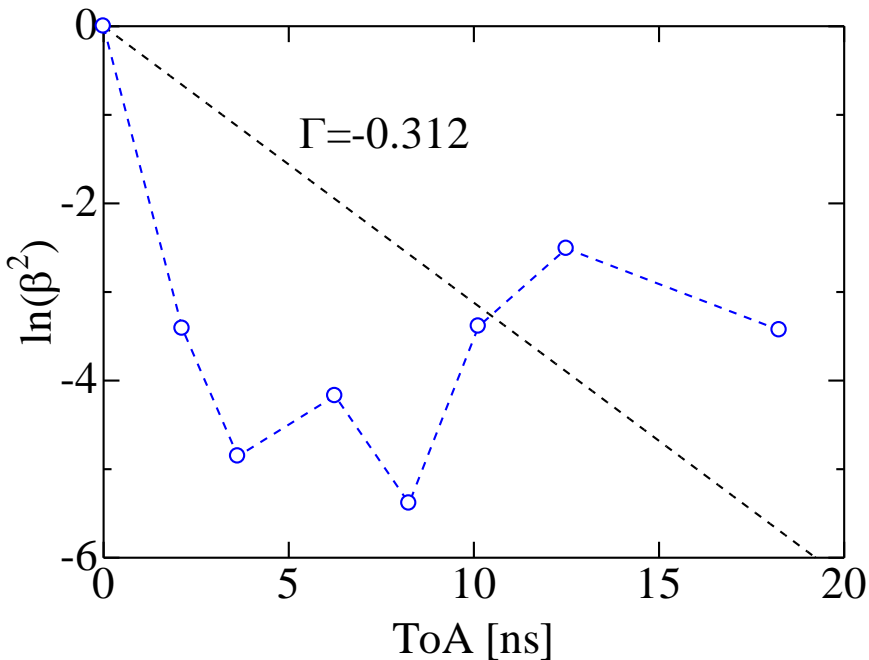

Summary

- Intra cluster channel model was proposed with extracted parameters for living, conference and cubicle environments
- Intra cluster parameter difference against HPBW (Living room environment) is shown
- Three measurement environment with three polarization were performed for T_{gad}
- Some inter cluster channel model parameter were extracted